

REVISIONS					
P	LTR	DESCRIPTION	DATE	DWN	APVD
	J	REV PER ECR 10-005107	08MAR10	JR	TM
	J1	REVISED PER ECO-17-007400	28NOV2017	RS	DR

AMP WIRE RANGE	Listed	LR7189 Certified
12-10 AWG SOLID OR STRANDED	12-10 AWG SOLID OR STRANDED	12-10 AWG SOLID OR STRANDED

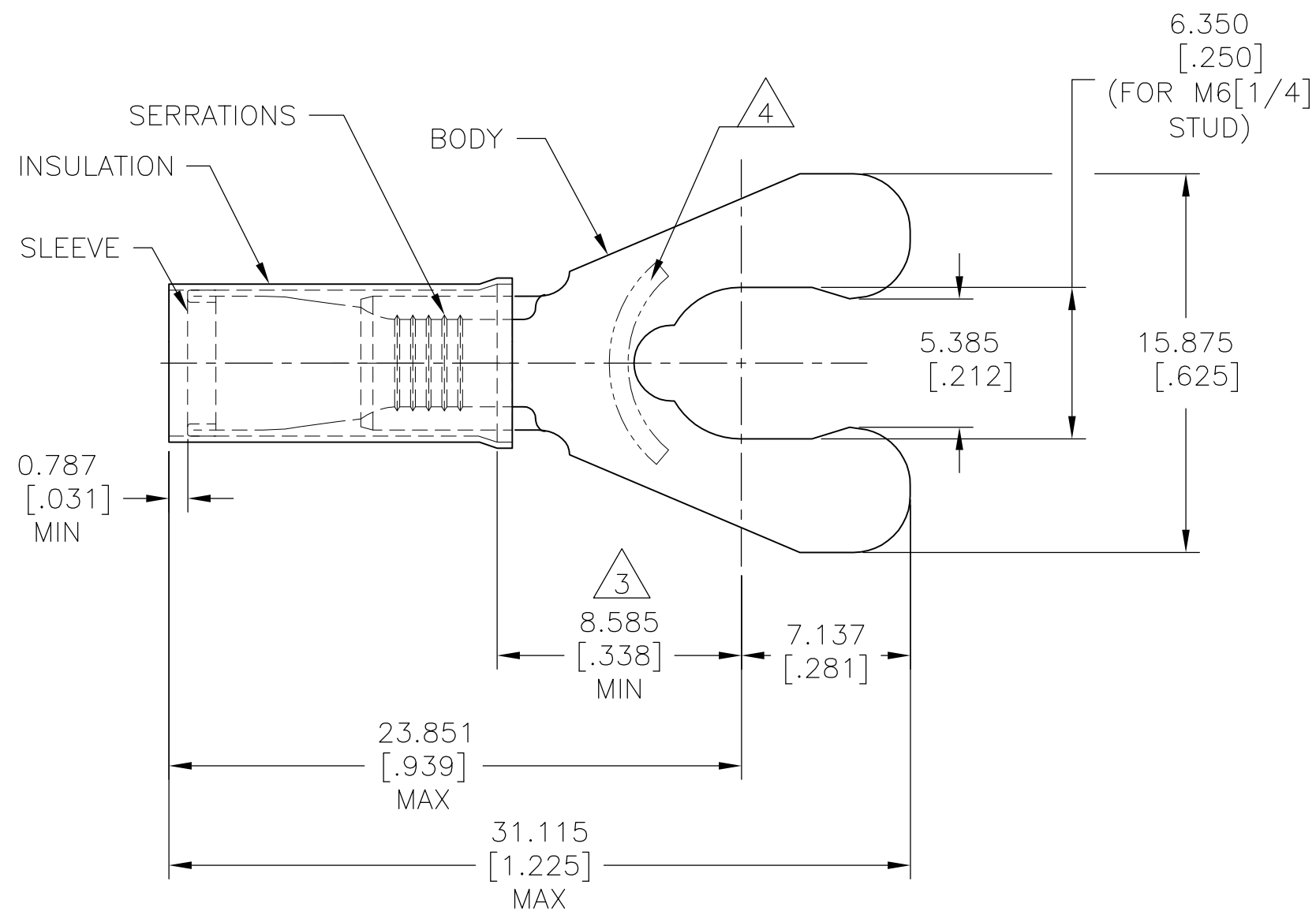

- 1 FOR WIRE INSULATION : $\phi 3.810[\phi.150]$ TO $\phi 6.350[\phi.250]$
- 2 BODY MATERIAL THK IS $1.016 \pm 0.076[.040 \pm .003]$
- 3 APPLIES FROM EDGE OF METAL WIRE BARREL TO CENTER OF STUD HOLE.
- 4 STAMP " 1/4 S AMP 12-10*", LOCATED APPROX AS SHOWN.
- 5 PRELIMINARY - NOT FOR PRODUCTION.
- 6 MATERIAL:
 BODY : PHOS. BRONZE PER ASTM B-103
 SLEEVE : COPPER PER ASTM B-152
 INSULATION : NYLON.
- 7 FINISH:
 BODY : TIN PLATE PER ASTM B-545
 SLEEVE : COPPER PER ASTM B-152
 INSULATION : COLOR-YELLOW.

1000	ON TAPE REEL	5 52945-1
500	WIRE TERMINAL	52945
QTY	DESCRIPTION	PART NO.

AMP INCORPORATED CUSTOMER SERVICE SYSTEMS		MAX RECOMMENDED OPERATING TEMPERATURE: 105°C [221°F]	THIS DRAWING IS A CONTROLLED DOCUMENT.		DWN JR RUTH 25OCT01	TE Connectivity			
FOR ADDITIONAL PRODUCT INFORMATION OR COPIES OF DRAWINGS AND TECHNICAL DOCUMENTS	PRODUCT INFORMATION CENTER 1-800-522-6752	VOLTAGE RATING: 300 V MAX	DIMENSIONS: mm [INCHES]	TOLERANCES UNLESS OTHERWISE SPECIFIED:	CHK MS FEHER 25OCT01				
FOR APPLICATION TOOLING INFORMATION	TOOLING ASSISTANCE CENTER 1-800-722-1111	CIRCULAR MIL AREA: 2.62-6.64mm² [5,180-13,100] SOLID OR STRANDED		0 PLC ± - 1 PLC ± - 2 PLC ± - 3 PLC ± 0.127[.005] 4 PLC ± - ANGLES ± 5°	APVD T MICHELUTTI 25OCT01	PRODUCT SPEC UL 486 A-B			
FOR ORDER ENTRY	1-800-526-5142	THIS DRAWING IS A CONTROLLED DOCUMENT FOR AMP INCORPORATED. IT IS SUBJECT TO CHANGE AND THE CONTROLLING ENGINEERING ORGANIZATION SHOULD BE CONTACTED FOR THE LATEST REVISION.	MATERIAL 6	FINISH 7	APPLICATION SPEC 114-2157	SIZE A3	CAGE CODE 00779	DRAWING NO C-52945	RESTRICTED TO -
					CUSTOMER DRAWING	SCALE 4:1	SHEET 1 OF 1	REV J1	