

Mechanical Dimensions: Inches [mm]

Tolerances ± 0.012 [0.3] Unless Otherwise Specified

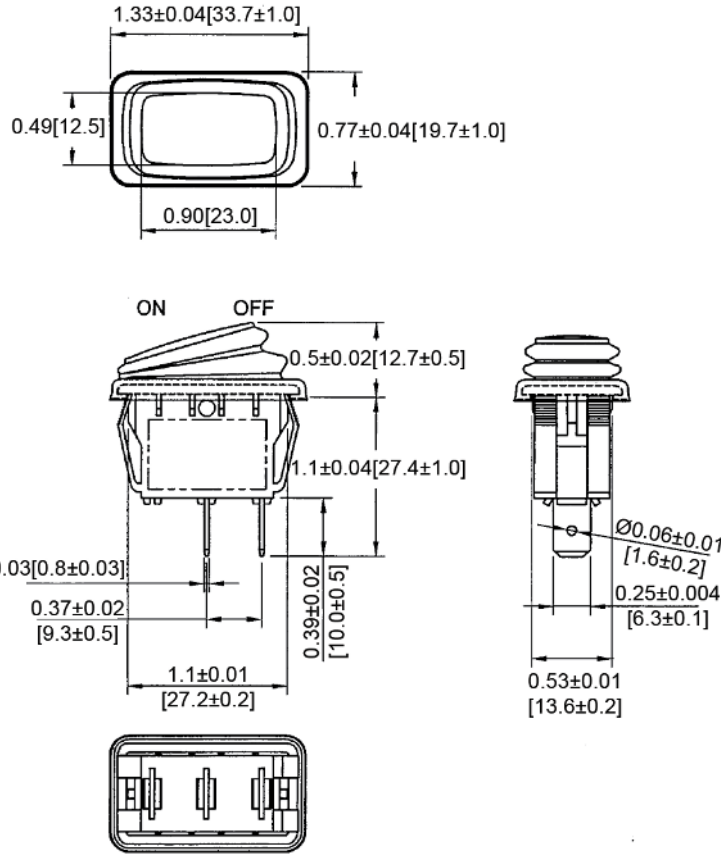

Mounting Hole

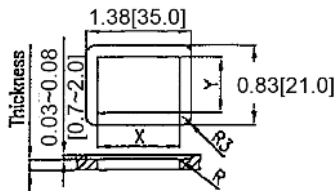

Thickness	X	Y
0.03~0.1 [0.75~2.5]	1.09 [27.6-0.1]	0.5 [13.8+0.1]
0.1~0.14 [2.5~3.5]	1.09 [27.8-0.1]	0.5 [13.8+0.1]
0.14~0.18 [3.5~4.5]	1.10 [28.0-0.1]	0.5 [13.8+0.1]

Circuit Diagram

2P SPST ON-OFF



Electrical Specifications

Rating	16A 12V DC, 10A 28V DC	Frame	Black, Nylon 66 (94-V2)
Contact Resistance	50m ohm Max.	Actuator	Black, Nylon#66+30%GF
Insulation Resistance	DC 500V 100M ohm Min.	Waterproof Rubber	Black, Silicone
Dielectric Strength	AC 1500V 1 minute	Terminals	Silver Plated, Copper Alloy
Operation Temperature	-25° C-85° C		IP65

Rev	Date of issue	Revision Notes	Designed	Approved
B	05-04-2020	Initial Drawing	RC	OF