



ON Semiconductor®

<http://onsemi.com>

# LA72910V

## Monolithic Linear IC FM Modulator and Demodulator IC

### Overview

The LA72910V is a FM modulation and demodulation single-chip IC. Its adjustment free modulation/demodulation circuit significantly reduces the number of peripheral circuits required and can contribute to lower production costs.

### Functions

- Video signal FM modulation and demodulation
- Video signal emphasis and de-emphasis function
- Drop-Out detecting function of Video FM signal
- FM mute function at Second-Call

### Specifications

#### Maximum Ratings at $T_a = 25^\circ\text{C}$

Parameter	Symbol	Conditions	Ratings	Unit
Maximum supply voltage	$V_{CC \text{ max}}$		7.0	V
Allowable power dissipation	$P_d \text{ max}$		300	mW
Operating temperature	$T_{opr}$	$T_a \leq 70^\circ\text{C}^*$	-30 to +70	$^\circ\text{C}$
Storage temperature	$T_{stg}$		-40 to +150	$^\circ\text{C}$

When mounted on a 114.3mm × 76.1mm × 1.6mm, glass epoxy.

Stresses exceeding Maximum Ratings may damage the device. Maximum Ratings are stress ratings only. Functional operation above the Recommended Operating Conditions is not implied. Extended exposure to stresses above the Recommended Operating Conditions may affect device reliability.

#### Recommended Operating Conditions at $T_a = 25^\circ\text{C}$

Parameter	Symbol	Conditions	Ratings	Unit
Recommended supply voltage	$V_{CC}$		5.0	V
Allowable operating voltage range	$V_{CC \text{ op}}$	$T_a = -30 \text{ to } +70^\circ\text{C}$	4.7 to 5.5	V

# LA72910V

**Electrical Characteristics** at Ta = 25°C, VCC = 5V

**DC CHARACTERISTICS** T6 = 0.4V, T9 = 2.0V, T10 = 0.4V

Parameter	Symbol	In	OUT	Conditions	Ratings			Unit
					min	typ	max	
Control terminal (Pin6,9) Low level	CNT6L CNT9L	T6 T9		Low level of control terminal of ALL mode. T6 = 0.4V(DEMOD mode), T9 = 0.4V (Standby mode)	0		0.4	V
Control terminal (Pin6,9)High level	CNT6H CNT9H	T6 T9		High level of input terminal of ALL mode T6 = 2.0V (MOD mode), T9 = 2.0V (Normal mode)	2.0		5.0	V
Input5 Low level	IN5L	T5		Low level of input terminal of MOD mode T6 = 2.0V, T9 = 2.0V, T10 = 0.4V	0		0.4	V
Input5 High level	IN5H	T5		High level of input terminal of MOD mode T6 = 2.0V, T9 = 2.0V, T10 = 0.4V	2.0		5.0	V
Input10 Low level	IN10L	T10		Low level of input terminal of MOD mode T5 = 0.4V, T6 = 2.0V, T9 = 2.0V	0		0.4	V
Input10 High level	IN10H	T10		High level of input terminal of MOD mode T5 = 0.4V, T6 = 2.0V, T9 = 2.0V	2.0		5.0	V
Output10 terminal High level	OPH10		T10	DEMODO mode: FM-Signal input T6 = 0.4V, T9 = 2.0V, Pull-UP:15KΩ	4.7			V
Output10 terminal Low level	OPL13 OPL18		T10	T10: DEMODO mode: FM No-signal Measure the sink level of output terminal. T6 = 0.4V, T9 = 2.0V, Pull-UP:15KΩ	0	0.25	0.4	V
Input12 Low level	IN12L	T12	T12	Voltage of terminal at AGC ON T6 = 0.4V, T9 = 2.0V	0		3	V
Input12 High level	IN12H	T12	T12	Voltage of terminal at AGC OFF T6 = 0.4V, T9 = 2.0V	4.5		5.0	V
5pin AC input dynamic range	ACIN5	T5A	T3	Input amplitude level of FM signal Freq: 11.5MHz to 13.5MHz			1000	mVp-p
16pin AC input dynamic range	ACIN16	T16A	T3	Maximum input level of T16A at Video signal			1.5	Vp-p

**Video FM Modulation Block (MOD)** T6=2.0V,T9=2.0V,T10=0.4V,T15=5V

Parameter	Symbol	In	OUT	Conditions	Ratings			Unit
					min	typ	max	
Current dissipation	ICCR			measure the currents into pins 2 (MOD mode)	19.5	23.0	26.5	mA
FM modulator output level	VFM1		T3	Measure the output level on T3 (No signal input) It is load impedance 200Ω between T3-GND.		1.8	2.2	Vp-p
FM Mute output level	VFM2		T3	Measure the T3 output level with 2nd call	0	10	20	mVp-p
Carrier frequency	FFM		T3	Measure the output frequency on T3 with no signal input	10.9	11.5	12.1	MHz
FM output Second harmonic distortion	THD2		T3	Measure the second harmonics distortion with the above condition		-30	-20	dB
Deviation	DEV	T16A	T3	With T16A 100% White 1Vp-p signal, Measure the deviation on T3	1.9	2.0	2.1	MHz
FM modulator linearity (11.5MHz to 13.5MHz)	LMOD	T16A	T3	Let f2.85, f3.35 and f3.85 be the output frequency when 2.85V, 3.35V and 3.85V is applied to T16A $L_{MOD} = \frac{f_{3.35} - (f_{3.85} + f_{2.85}) / 2}{f_{3.85} - f_{2.85}} \times 100$	-2	0	+2	%
Emphasis gain	GEMP	T16A	T12	With VIN a 300mVp-p 10kHz sine wave, Measure the ratio of the levels on T16A and T12	-7.5	-6.0	-4.5	dB
Main linear emphasis characteristics(1)	GME1	T16A	T12	With VIN a 300mVp-p 500kHz sine wave, Measure the ratio of the levels on T16A and T12	-1.5	0.0	+1.5	dB
Main linear emphasis characteristics(2)	GME2	T16A	T12	With VIN a 300mVp-p 2MHz sine wave, Measure the ratio of the levels on T16A and T12	2.5	4.0	5.5	dB
White clipping level	LWC	T16A	T12	With VIN a 1.5Vp-p 100% white video signal. Measure the white clipping level on T12	180	200	220	%
Dark clipping level	LDC	T16A	T12	With VIN a 1.5Vp-p 100% white video signal. Measure the dark clipping level on T12.	-60	-50	-40	%
FM stop beginning delay time (VD characteristic 1B)	TC1	T5	T3	C7=0.01μF, Time from fall of T5 signal to doing of FM carrier of T3 STOP	240	300	360	μsec
FM stop time (VD characteristic2A)	TC2	T5	T3	C8=0.001μF, Stop time of FM carrier of T3	30	40	50	μsec
Minimum VD pulse width	VDT	T5	T3	C7=0.01μF, Minimum VD pulse width to which TC1B is normally output	63			μsec

# LA72910V

## Video FM De-modulation Block (DEM0D) T6=0.4V,T9=2.0V

Parameter	Symbol	In	OUT	Conditions	Ratings			Unit
					min	typ	max	
Current dissipation	I <sub>CCP</sub>			Measure the currents into pin 2 (DEM0D mode)	24.0	28.0	32.0	mA
Video output level	VOUT	T5A	T3	Demodulation level, when the FM signal of 2.2MHz deviation. Load impedance = 1kΩ T3-GND.	2.09	2.2	2.31	Vpp
Video output level B	VOUTB	T5A	T3	Demodulation level, when the FM signal of 2.0MHz deviation. Load impedance = 1kΩ T3-GND. In this case only, V <sub>CC</sub> make 4.5V to 5.5V.	1.9	2.0	2.1	Vpp
FM stop detection level (DOC characteristic 1)	DOC1	T5A T12	T10 T12	T5 = 11.5MHz, 300mVp-p. Measure T12 voltage (V12). Set T12 V12 (AGC-Fix). T5 input level when T5 amplitude is decrease gradually, and T10 becomes "Low"		40	60	mVp-p
(Drop Delay Down)	DDD	T5A T12	T10 T12	Shift time from T5=300mVp-p→0mVp-p to T10"Low".	0.5	1.5	2.5	μsec
FM return judgment level	DOC2	T5A T12	T10 T12	T5=11.5MHz, 300mVpp, Measure T12 Voltage (V12). Set T12 V12 (AGC-Fix). T5 inputs the level when T5 amplitude is increase gradually, and T10 becomes "High"		60	90	mVp-p
Video DC level when returning	DOC2B	T5A T12	T15	Confirmation of output of Video signal from T3. Measurement of DC level.	0.5	1.0	1.5	V
(Drop Delay Rise) Return operation delay time	DWR	T5A T12	T10 T12	Shift time from T5 = 0mVp-p→300mVp-p to T10"High"	0.2	1.5	2.5	μsec
4V Regulator	VREG		T4	Measurement of T4 DC level.	3.9	4.0	4.3	V
Range of input Dynamic range	ACIN5	T5A	T3	DEV = 2.0MHz. Input amplitude level of FM signal. (T5A: 11.5MHz to 13.5MHz)		500	1000	mVp-p
DG	DG	T5A	T3		0	6	10	%
DP	DP	T5A	T3		0	6	10	deg
Output voltage at mute	MUV		T3	Mute level measurement of T3	0	10	20	IRE
FM demodulation voltage (11.0M)	VDEM11 VDEM12 VDEM13	T5A	T15	T5A = 11MHz, 100mVp-p, 200mVp-p and 400mVp-p. Each T15 voltage measurement	0.3	0.8	1.3	V
FM demodulation voltage (12.5M)	VDEM21 VDEM22 VDEM23	T5A	T15	T5A = 12.5MHz, 100mVp-p, 200mVp-p and 400mVp-p. Each T15 voltage measurement	0.7	1.2	1.7	V
FM demodulation voltage (14.0M)	VDEM31 VDEM32 VDEM33	T5A	T15	T5A = 14MHz, 100mVp-p, 200mVp-p and 400mVp-p Each T15 voltage measurement	1.1	1.6	2.1	V
FM demodulation linearity1.2.3	LDEM1 LDEM2 LDEM3			Calculate FM demodulation linearity LDEM1 = {[VDEM21 - (VDEM11 + VDEM31) / 2] / (VDEM31 - VDEM11)}×100 LDEM2 = {[VDEM22 - (VDEM12 + VDEM32) / 2] / (VDEM32 - VDEM12)}×100 LDEM3 = {[VDEM23 - (VDEM13 + VDEM33) / 2] / (VDEM33 - VDEM13)}×100	-2	0	+2	%
FM demodulation Sensitivity1.2.3	SDEM1 SDEM2 SDEM3			Calculate FM recovery Sensitivity with consider pin3 output level conversion ratio. SDEM1 = (VDEM31-VDEM11)/2.5 SDEM2 = (VDEM32-VDEM12)/2.5 SDEM3 = (VDEM33-VDEM13)/2.5	0.28	0.33	0.38	V/MHz
Main linear de-emphasis amplitude	GMED	T5A	T15	T5=200mVp-p FM signal (fm = 10kHz, Center Carrier = 12.5MHz, DEV = 1.0MHz) Signal level of T15	243	270	297	mVp-p
Main linear de-emphasis Characteristics(1)	GMED1	T5A	T15	T5 = 200mVp-p FM signal (fm = 500kHz, Center Carrier = 12.5MHz, DEV = 1.5MHz). Signal level of T15 versus GMRD (Ratio of GMED).	-8.0	-6.0	-4.0	dB
Main linear de-emphasis Characteristics(2)	GMED2	T5A	T15	T5 = 200mVp-p FM signal (fm = 2MHz, Center Carrier = 9.25MHz, DEV = 1.5MHz). Signal level of T15 versus GMRD (Ratio of GMED)	-11.0	-9.0	-7.0	dB

# LA72910V

Standby (Standby mode) T9=0.4V

Parameter	Symbol	In	OUT	Conditions	Ratings			Unit
					min	typ	max	
Current dissipation at standby	I <sub>CCS</sub>	T9		Measure the currents into pin 2. (Standby mode)	5.0	8.0	11.0	mA
Standby release time(1) (FM stop→release)	SASK1	T6 T9	T3	T6 = 2.0VDC T9 = 0V→2V (Standby release) Time until FM carrier is output to T3.	0.0	1.0	2.0	usec
Standby release time(2) (Video signal stop →release)	SASK2	T6 T5A T9	T3	T6 = 0.4V, T5 = DEV = 1.5MHz 100% white video signal of FM signal. T9 = 0V→2V (Standby release), Time until white 100% signal is output to T3	2.0	7.0	12.0	usec

## Package Dimensions

unit : mm (typ)

3178B

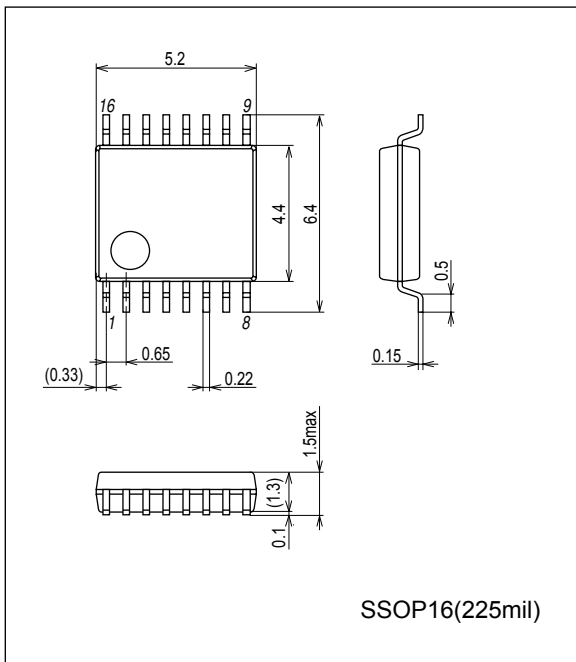

## Pin Assignment

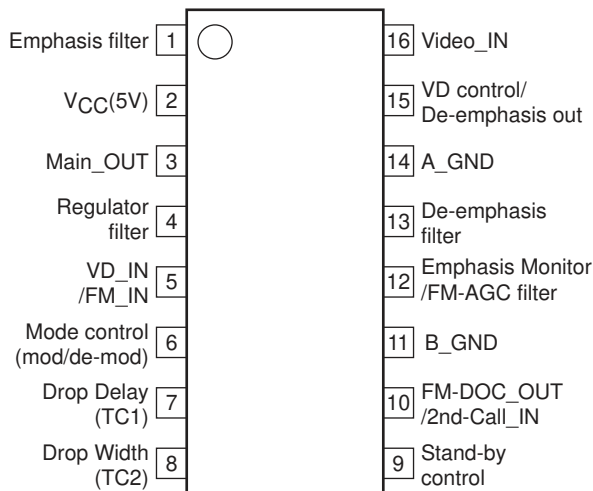

Top view

# LA72910V

## Block Diagram and Application Circuit Example 1 Modulation (Camera)

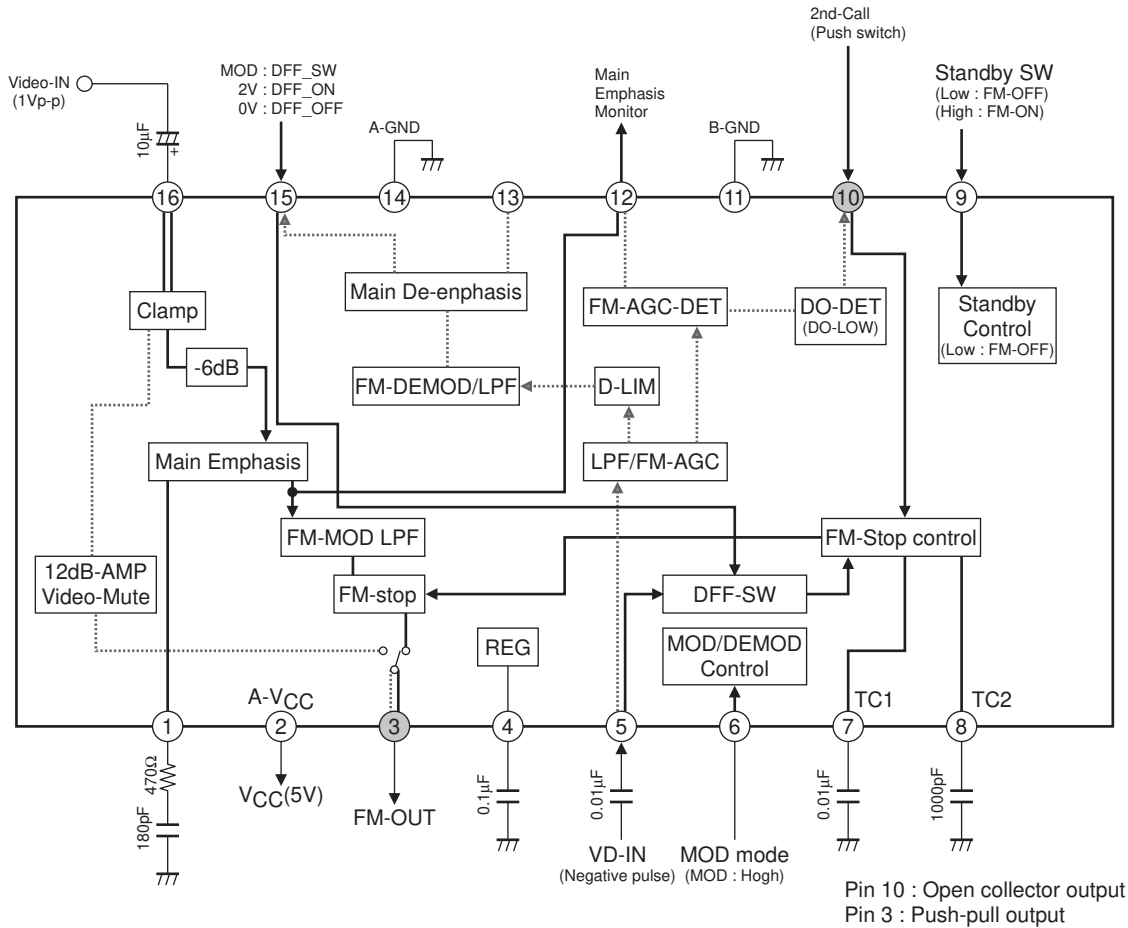

## Application Circuit Example 2 Demodulation (Monitor)

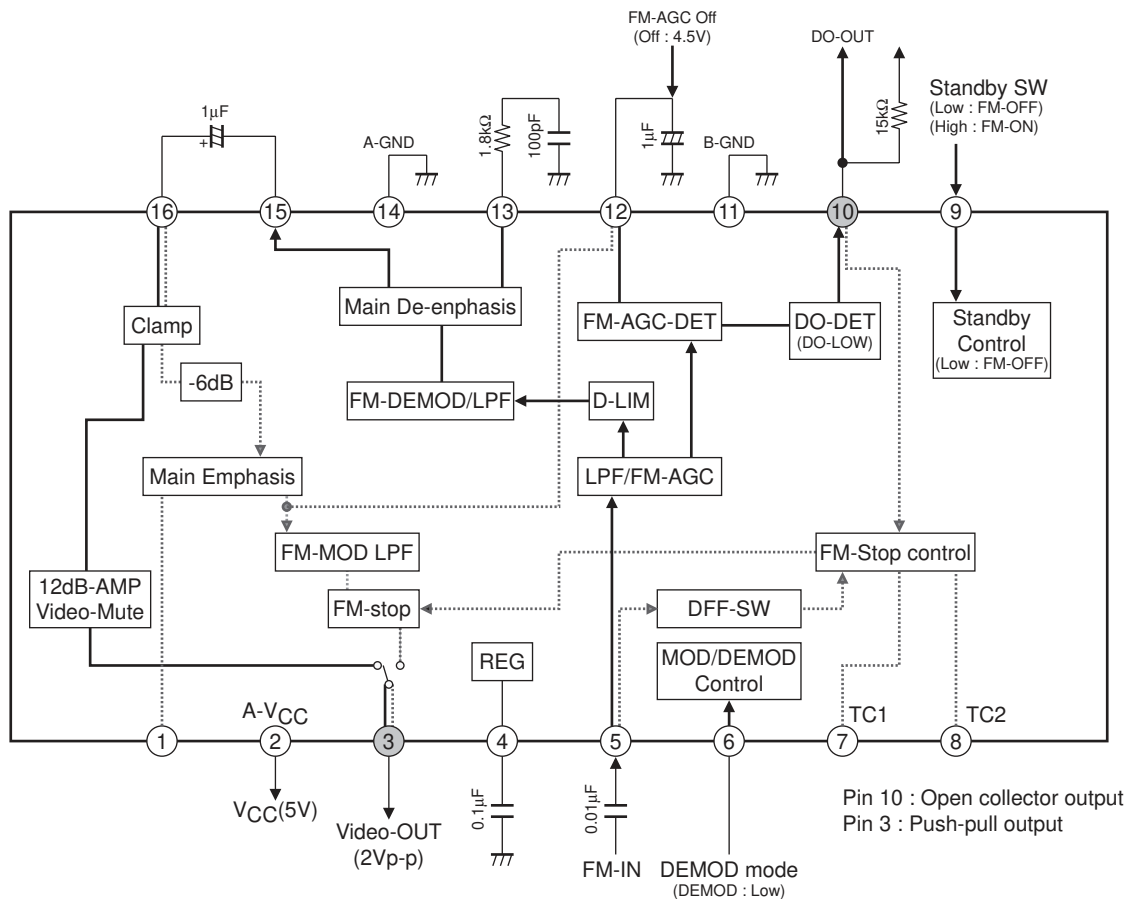

# LA72910V

## Pin Function

Pin No.	Pin name	FM MOD mode(Outside camera)	FM DEMOD mode(Inside Monitor)	Note
1	Emphasis filter	Emphasis filter connection pin	Non connect(Hi-Z)	If you don't need, this pin is open.
2	V <sub>CC</sub> 5V	V <sub>CC</sub> for FM modulation.	V <sub>CC</sub> for FM demodulation.	
3	Main_OUT	FM Output (R <sub>o</sub> =200Ω:1.8Vp-p)	Video Output (R <sub>o</sub> =1kΩ:2Vp-p)	Push-pull output
4	Regulator filter	FM modulation block reference DC power supply.	FM demodulation block reference DC power supply.	
5	VD_IN/FM_IN	VD Input (Hi: over 2V, Low: under 0.4V) (VD DET: High)	FM Input (Recommend Level: 100 to 620mVp-p)	DEMOD mode:Set 3.3V by internal bias. (34kΩ/66kΩ)
6	Mode control	Set over 2V DC voltage.	Set under 0.4V DC voltage.	Outside camera / Inside monitor setting.
7	Drop delay (TC1)	Connect TC1 setting C.	Non connect(Hi-Z)	
8	Drop Width (TC2)	Connect TC2 setting C.	Non connect(Hi-Z)	
9	Stand-by control	FM blocks standby control. (FM block operate: over 2V , FM block standby: under 0.4V )	←	
10	FM-DOC-OUT /2nd-Call control	2nd-Call input, 2nd-Call: Low (High: over 2V, Low: under 0.4V)	DOC output (When DO-DET, output is Low)	DEMOD mode: Open collector output.
11	B-GND	Circuit GND	←	
12	Emphasis Monitor /FM-AGC filter	Emphasis monitor output	FM AGC control filter (AGC-ON: 0 to 3V DC, AGC-OFF: 4.5V to 5V by external DC voltage.)	MOD mode: Don't connect capacitor.
13	De-emphasis filter	Non connect(Hi-Z)	De-emphasis filter connection pin.	If you don't need, this pin is open.
14	A-GND	Circuit GND	←	
15	VD control /De-emphasis out	DFF control (ON: over 2V, OFF: under 0.4V)	DE-emphasis output	
16	Video_IN	Video signal input (from outside CCD camera: 1Vp-p).	Video signal input (from de-emphasis block: 0.5Vp-p).	MOD mode: Maximum video input level is 1.5Vp-p.

# LA72910V

## Pin Description

Pin No.	Pin Name	Description	Equivalent circuit
1	Emphasis filter	Main Emphasis filter pin. Before FM Modulation, make emphasis characteristic at video signal. Emphasis time constant must be matching at de-emphasis time constant. (If you don't need the emphasis, this pin is open.)	
2	V <sub>CC</sub> 5V	V <sub>CC</sub> pin. Supply voltage is 5V DC. Please connect de-coupling capacitor.	
3	Main_OUT	Push-Pull output pin. MOD mode: FM carrier output. (1.8Vp-p: R <sub>out</sub> =200Ω) DEMOD mode: Video signal output. (2.0Vp-p: R <sub>out</sub> =1kΩ)	
4	Regulator filter	Internal regulator filter pin. Please connect 0.1μF (C1)	
5	VD_IN/FM_IN	DEMOD mode: FM signal input. Internal DC bias is 3.3V. Please use capacitor (C1) coupling. MOD mode: VD signal input. Please input VD signal directly. Please consider input impedance.	
6	Mode control	MOD mode/ DEMOD mode setting pin. MOD mode: Please set over 2V DC voltage. (2 to 5V). DEMOD mode: Please set under 0.4V DC voltage. (0 to 0.4V).	

Continued on next page.

# LA72910V

Continued from preceding page.

Pin No.	Pin Name	Description	Equivalent circuit
7	Drop delay (TC1)	MOD mode: TC1 filter pin. Please connect C1.	
8	Drop Width (TC2)	MOD mode: TC2 filter pin. Please connect C1.	
9	Stand-by control	Standby control pin. FM block standby: under 0.4V DC voltage. (0 to 0.4V) FM block operate: over 2V DC voltage. (2 to 5V)	
10	FM-DOC-OUT /2nd-Call control	DEMODO mode: Drop-out output pin. This pin is open collector output, so please connect pull up resistor. MOD mode: 2nd-CALL input. 2nd-CALL input: under 0.4V (0 to 0.4V) DC. Normal: over 2V DC voltage. (2 to 5V)	
11	B-GND	Circuit GND.	
12	Emphasis Monitor /FM-AGC filter	MOD mode: Emphasis monitor pin. DEMODO mode: FM AGC filter pin. If FM AGC no need (=AGC Off), Please set pin12 voltage over 4.5V DC voltage. (4.5 to 5V)	

Continued on next page.



# LA72910V

Continued from preceding page.

Pin No.	Pin Name	Description	Equivalent circuit
13	De-emphasis filter	<p>DEMODO mode: De-emphasis filter pin.</p> <p>De-emphasis time constant must be matching at emphasis time constant.</p> <p>(If you don't need the emphasis, this pin is open.)</p>	
14	A-GND	Circuit GND.	
15	VD control /De-emphasis out	<p>DEMODO mode: Video signal output after De-emphasis.</p> <p>Output level is 0.5Vp-p.</p> <p>Connect capacitor to clamp input (pin 16).</p> <p>MOD mode: DFF control pin. DFF is ON at over 2V DC voltage. (2 to 5V)</p>	
16	Video_IN	<p>MOD mode: Video signal input pin (from camera).</p> <p>Input level is 1Vp-p.</p> <p>DEMODO mode: Video signal input pin (from de-emphasis).</p> <p>Input level is 0.5Vp-p.</p>	

# LA72910V

## Test Circuit

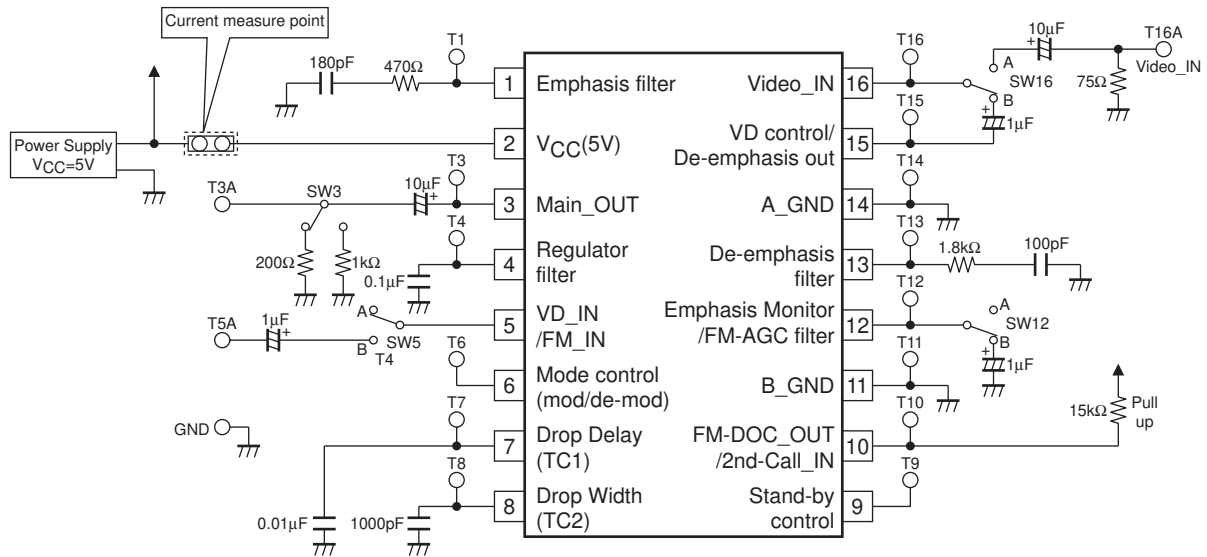

ON Semiconductor and the ON logo are registered trademarks of Semiconductor Components Industries, LLC (SCILLC). SCILLC owns the rights to a number of patents, trademarks, copyrights, trade secrets, and other intellectual property. A listing of SCILLC's product/patent coverage may be accessed at [www.onsemi.com/site/pdf/Patent-Marking.pdf](http://www.onsemi.com/site/pdf/Patent-Marking.pdf). SCILLC reserves the right to make changes without further notice to any products herein. SCILLC makes no warranty, representation or guarantee regarding the suitability of its products for any particular purpose, nor does SCILLC assume any liability arising out of the application or use of any product or circuit, and specifically disclaims any and all liability, including without limitation special, consequential or incidental damages. "Typical" parameters which may be provided in SCILLC data sheets and/or specifications can and do vary in different applications and actual performance may vary over time. All operating parameters, including "Typicals" must be validated for each customer application by customer's technical experts. SCILLC does not convey any license under its patent rights nor the rights of others. SCILLC products are not designed, intended, or authorized for use as components in systems intended for surgical implant into the body, or other applications intended to support or sustain life, or for any other application in which the failure of the SCILLC product could create a situation where personal injury or death may occur. Should Buyer purchase or use SCILLC products for any such unintended or unauthorized application, Buyer shall indemnify and hold SCILLC and its officers, employees, subsidiaries, affiliates, and distributors harmless against all claims, costs, damages, and expenses, and reasonable attorney fees arising out of, directly or indirectly, any claim of personal injury or death associated with such unintended or unauthorized use, even if such claim alleges that SCILLC was negligent regarding the design or manufacture of the part. SCILLC is an Equal Opportunity/Affirmative Action Employer. This literature is subject to all applicable copyright laws and is not for resale in any manner.