



# Intel<sup>®</sup> Celeron<sup>®</sup> D Processor 300<sup>△</sup> Sequence

**Datasheet**

---

*– On 90 nm Process in the 775-Land Package*

*December 2005*



INFORMATION IN THIS DOCUMENT IS PROVIDED IN CONNECTION WITH INTEL PRODUCTS. NO LICENSE, EXPRESS OR IMPLIED, BY ESTOPPEL OR OTHERWISE, TO ANY INTELLECTUAL PROPERTY RIGHTS IS GRANTED BY THIS DOCUMENT. EXCEPT AS PROVIDED IN INTEL'S TERMS AND CONDITIONS OF SALE FOR SUCH PRODUCTS, INTEL ASSUMES NO LIABILITY WHATSOEVER, AND INTEL DISCLAIMS ANY EXPRESS OR IMPLIED WARRANTY, RELATING TO SALE AND/OR USE OF INTEL PRODUCTS INCLUDING LIABILITY OR WARRANTIES RELATING TO FITNESS FOR A PARTICULAR PURPOSE, MERCHANTABILITY, OR INFRINGEMENT OF ANY PATENT, COPYRIGHT OR OTHER INTELLECTUAL PROPERTY RIGHT. INTEL PRODUCTS ARE NOT INTENDED FOR USE IN MEDICAL, LIFE SAVING, OR LIFE SUSTAINING APPLICATIONS.

Intel may make changes to specifications and product descriptions at any time, without notice.

Designers must not rely on the absence or characteristics of any features or instructions marked "reserved" or "undefined." Intel reserves these for future definition and shall have no responsibility whatsoever for conflicts or incompatibilities arising from future changes to them.

The Intel® Celeron® D processor 300 sequence on 90 nm process and in the 775-land package may contain design defects or errors known as errata which may cause the product to deviate from published specifications. Current characterized errata are available on request.

<sup>^</sup>Intel processor numbers are not a measure of performance. Processor numbers differentiate features within each processor family, not across different processor families. Over time processor numbers will increment based on changes in clock, speed, cache, FSB, or other features, and increments are not intended to represent proportional or quantitative increases in any particular feature. Current roadmap processor number progression is not necessarily representative of future roadmaps. See [www.intel.com/products/processor\\_number](http://www.intel.com/products/processor_number) for details.

<sup>Φ</sup>Intel® Extended Memory 64 Technology (Intel® EM64T) requires a computer system with a processor, chipset, BIOS, operating system, device drivers and applications enabled for Intel EM64T. Processor will not operate (including 32-bit operation) without an Intel EM64T-enabled BIOS. Performance will vary depending on your hardware and software configurations. See <http://www.intel.com/info/em64t> for more information including details on which processors support EM64T or consult with your system vendor for more information.

Enabling Execute Disable Bit functionality requires a PC with a processor with Execute Disable Bit capability and a supporting operating system. Check with your PC manufacturer on whether your system delivers Execute Disable Bit functionality.

Contact your local Intel sales office or your distributor to obtain the latest specifications and before placing your product order.

Intel, Celeron, Pentium, Itanium, Intel Xeon, Intel NetBurst and the Intel logo are trademarks or registered trademarks of Intel Corporation or its subsidiaries in the United States and other countries.

\*Other names and brands may be claimed as the property of others.

Copyright © 2004–2005 Intel Corporation. All rights reserved.



# Contents

---

1	Introduction.....	11
	1.1 Terminology.....	12
	1.1.1 Processor Packaging Terminology.....	12
	1.2 References.....	13
2	Electrical Specifications.....	15
	2.1 FSB and GTLREF.....	15
	2.2 Power and Ground Lands.....	15
	2.3 Decoupling Guidelines.....	15
	2.3.1 VCC Decoupling.....	16
	2.3.2 FSB GTL+ Decoupling.....	16
	2.3.3 FSB Clock (BCLK[1:0]) and Processor Clocking.....	16
	2.4 Voltage Identification.....	17
	2.4.1 Phase Lock Loop (PLL) Power and Filter.....	19
	2.5 Reserved, Unused, and TESTHI Signals.....	20
	2.6 FSB Signal Groups.....	20
	2.7 GTL+ Asynchronous Signals.....	22
	2.8 Test Access Port (TAP) Connection.....	23
	2.9 FSB Frequency Select Signals (BSEL[2:0]).....	23
	2.10 Absolute Maximum and Minimum Ratings.....	23
	2.11 Processor DC Specifications.....	24
	2.11.1 Processor DC Specifications.....	24
	2.12 VCC Overshoot Specification.....	30
	2.12.1 Die Voltage Validation.....	30
	2.13 GTL+ FSB Specifications.....	31
3	Package Mechanical Specifications.....	33
	3.1 Package Mechanical Drawing.....	33
	3.2 Processor Component Keep-Out Zones.....	37
	3.3 Package Loading Specifications.....	37
	3.4 Package Handling Guidelines.....	37
	3.5 Package Insertion Specifications.....	38
	3.6 Processor Mass Specification.....	38
	3.7 Processor Materials.....	38
	3.8 Processor Markings.....	38
	3.9 Processor Land Coordinates.....	40
4	Land Listing and Signal Descriptions.....	41
	4.1 Processor Land Assignments.....	41
	4.2 Alphabetical Signals Reference.....	62
5	Thermal Specifications and Design Considerations.....	71
	5.1 Processor Thermal Specifications.....	71
	5.1.1 Thermal Specifications.....	71
	5.1.2 Thermal Metrology.....	74
	5.2 Processor Thermal Features.....	74
	5.2.1 Thermal Monitor.....	74

	5.2.2	Thermal Monitor 2 .....	75
	5.2.3	On-Demand Mode.....	76
	5.2.4	PROCHOT# Signal .....	77
	5.2.5	THERMTRIP# Signal .....	77
	5.2.6	T <sub>CONTROL</sub> and Fan Speed Reduction .....	77
	5.2.7	Thermal Diode.....	78
6		Features .....	79
	6.1	Power-On Configuration Options .....	79
	6.2	Clock Control and Low Power States.....	79
	6.2.1	Normal State .....	80
	6.2.2	HALT Powerdown State .....	80
	6.2.3	Stop-Grant States .....	81
	6.2.4	HALT Snoop State, Grant Snoop State .....	81
7		Boxed Processor Specifications.....	83
	7.1	Mechanical Specifications.....	84
	7.1.1	Boxed Processor Cooling Solution Dimensions .....	84
	7.1.2	Boxed Processor Fan Heatsink Weight.....	86
	7.1.3	Boxed Processor Retention Mechanism and Heatsink Attach Clip Assembly .....	86
	7.2	Electrical Requirements .....	86
	7.2.1	Fan Heatsink Power Supply .....	86
	7.3	Thermal Specifications .....	88
	7.3.1	Boxed Processor Cooling Requirements .....	88
	7.3.2	Variable Speed Fan .....	90
8		Debug Tools Specifications.....	93
	8.1	Logic Analyzer Interface (LAI).....	93
	8.1.1	Mechanical Considerations .....	93
	8.1.2	Electrical Considerations.....	93



## Figures

2-1	Phase Lock Loop (PLL) Filter Requirements .....	19
2-2	VCC Static and Transient Tolerance for 775_VR_CONFIG_04A .....	27
2-3	VCC Overshoot Example Waveform .....	30
3-1	Processor Package Assembly Sketch.....	33
3-2	Processor Package Drawing 1 .....	34
3-3	Processor Package Drawing 2 .....	35
3-4	Processor Package Drawing 3 .....	36
3-5	Processor Top-Side Marking Example (with Processor Number) .....	38
3-6	Processor Top-Side Marking Example .....	39
3-7	Processor Land Coordinates (Top View) .....	40
4-1	Landout Diagram (Top View – Left Side) .....	42
4-2	Landout Diagram (Top View – Right Side).....	43
5-1	Thermal Profile for Platform Compatibility Guide '04 A Processors .....	73
5-2	Case Temperature (TC) Measurement Location.....	74
5-3	Thermal Monitor 2 Frequency and Voltage Ordering .....	76
6-1	Processor Low Power State Machine .....	80
7-1	Mechanical Representation of the Boxed Processor .....	83
7-2	Space Requirements for the Boxed Processor (Side View).....	84
7-3	Space Requirements for the Boxed Processor (Top View).....	85
7-4	Space Requirements for the Boxed Processor (Overall View).....	85
7-5	Boxed Processor Fan Heatsink Power Cable Connector Description.....	87
7-6	Baseboard Power Header Placement Relative to Processor Socket.....	88
7-7	Boxed Processor Fan Heatsink Airspace Keep-out Requirements (Top View) ..	89
7-8	Boxed Processor Fan Heatsink Airspace Keep-out Requirements (Side View) .	89
7-9	Boxed Processor Fan Heatsink Set Points .....	90

## Tables

1-1	References.....	13
2-1	Core Frequency to FSB Multiplier Configuration.....	16
2-2	Voltage Identification Definition.....	18
2-3	FSB Signal Groups.....	21
2-4	Signal Characteristics.....	22
2-5	Signal Reference Voltages.....	22
2-6	BSEL[2:0] Frequency Table for BCLK[1:0].....	23
2-7	Processor DC Absolute Maximum Ratings.....	24
2-8	Voltage and Current Specifications.....	25
2-9	VCC Static and Transient Tolerance for 775_VR_CONFIG_04A Processors....	26
2-10	GTL+ Asynchronous Signal Group DC Specifications.....	28
2-11	GTL+ Signal Group DC Specifications.....	28
2-12	PWRGOOD and TAP Signal Group DC Specifications.....	29
2-13	VTTTPWRGD DC Specifications.....	29
2-14	BSEL [2:0] and VID[5:0] DC Specifications.....	29
2-15	BOOTSELECT DC Specifications.....	29
2-16	VCC Overshoot Specifications.....	30
2-17	GTL+ Bus Voltage Definitions.....	31
3-1	Processor Loading Specifications.....	37
3-2	Package Handling Guidelines.....	37
3-3	Processor Materials.....	38
4-1	Alphabetical Land Assignments.....	44
4-2	Numerical Land Assignments.....	53
4-3	Signal Description.....	62
5-1	Processor Thermal Specifications.....	72
5-2	Thermal Profile for Processors.....	73
5-3	Thermal Diode Parameters.....	78
5-4	Thermal Diode Interface.....	78
6-1	Power-On Configuration Option Signals.....	79
7-1	Fan Heatsink Power and Signal Specifications.....	87
7-2	Boxed Processor Fan Heatsink Set Points.....	91



## Revision History

---

Revision Number	Description	Date
-001	<ul style="list-style-type: none"><li>Initial release</li></ul>	September 2004
-002	<ul style="list-style-type: none"><li>Added 3.06 GHz processor</li></ul>	November 2004
-003	<ul style="list-style-type: none"><li>Updated Clock Control and Low Power States section in chapter 6</li></ul>	December 2004
-004	<ul style="list-style-type: none"><li>Added support for processor numbers 346, 341, 336, 331, and 326</li><li>Added the letter "J" to processor numbers 345J, 340J, 335J, 330J and 325J</li><li>Added EM64T support</li></ul>	June 2005
-005	<ul style="list-style-type: none"><li>Added support for processor number 351</li></ul>	June 2005
-006	<ul style="list-style-type: none"><li>Added support for processor number 355</li></ul>	December 2005

§







## Intel® Celeron® D Processor 300 Sequence Features

---

- Available at 3.33 GHz, 3.20 GHz, 3.06 GHz, 2.93 GHz, 2.80 GHz, 2.66 GHz, and 2.53 GHz
- Binary compatible with applications running on previous members of the Intel microprocessor line
- FSB frequencies at 533 MHz
- Hyper-Pipelined Technology
  - Advance Dynamic Execution
  - Very deep out-of-order execution
- Enhanced branch prediction
- Optimized for 32-bit applications running on advanced 32-bit operating systems
- 775-Land Package
- 16-KB Level 1 data cache
- 256-KB Advanced Transfer Cache (on-die, full-speed Level 2 (L2) cache) with 4-way associativity and Error Correcting Code (ECC)
- 144 Streaming SIMD Extensions 2 (SSE2) instructions
- Supports Execute Disable Bit capability
- 13 Streaming SIMD Extensions 3 (SSE3) instructions
- Power Management capabilities
  - System Management mode
  - Multiple low-power states

The Intel® Celeron® D processor family expands Intel's processor family into the value-priced PC market segment. Celeron D processors provide the value that offers the customer the capability to affordably get onto the Internet, and use educational programs, home-office software, and productivity applications. All of the Celeron D processors include an integrated L2 cache, and are built on Intel's advanced CMOS process technology. The Celeron D processor is backed by over 30 years of Intel experience in manufacturing high-quality, reliable microprocessors.

Intel® Extended Memory 64 Technology (Intel® EM64T) enables Celeron D processors to execute operating systems and applications written to take advantage of the Intel EM64T.

The Celeron D processor also includes the Execute Disable Bit capability. This feature, combined with a supported operating system, allows memory to be marked as executable or non-executable.

§



# 1 Introduction

---

The Intel® Celeron® D processor 300 sequence on 90 nm process and in the 775-land package is a follow-on to the Intel® Celeron® D processor in the 478-pin package. This processor uses Flip-Chip Land Grid Array (FC-LGA4) package technology, and plugs into a 775-land LGA socket, referred to as the LGA775 socket. LGA775 is required to support higher frequency processors. This next generation of socket provides longevity for processor support beyond 2004. LGA775 designs support the Celeron D processor providing great flexibility and breadth of processor choices.

The Intel Celeron D processor 300 sequence on 90 nm process in the 775-land package supports Intel® Extended Memory 64 Technology (Intel EM64T)™ as an enhancement to Intel's IA-32 architecture. This enhancement enables the processor to execute operating systems and applications written to take advantage of Intel EMT64T. With appropriate 64 bit supporting hardware and software, platforms based on an Intel processor supporting Intel EM64T can enable use of extended virtual and physical memory. Further details on the 64-bit extension architecture and programming model is provided in the *Intel® Extended Memory 64 Technology Software Developer Guide* at <http://developer.intel.com/technology/64bitextensions/>.

**Note:** In this document the Celeron D processor on 90 nm process and in the 775-land package is also referred to as Celeron D processor in the 775-land package or as the “processor”.

**Note:** In this document, unless otherwise specified, the Intel® Celeron® D processor 300 sequence refers to Intel Celeron D processors 355, 351, 345J/346, 340J/341, 335J/336, 330J/331, and 325J/326.

**Note:** Intel® Celeron® D processors 355, 351, 346, 341, 336, 331, and 326 support Intel® Extended Memory 64 Technology (Intel EM64T)

The Celeron D processor in the 775-land package, like its predecessor, the Celeron D processor in the 478-pin package, is based on the same Intel 32-bit microarchitecture and maintains the tradition of compatibility with IA-32 software. It maintains the same Front Side Bus (FSB) data transfer speed at 533 MT/s and Level 2 cache size of 256 KB.

The Celeron D Processor in the 775-Land Package includes the Execute Disable Bit capability previously available in Intel® Itanium® processors. This feature, combined with a supported operating system, allows memory to be marked as executable or nonexecutable. If code attempts to run in non-executable memory, the processor generates an error to the operating system. This feature can prevent some classes of viruses or worms that exploit buffer overrun vulnerabilities and can, thus, help improve the overall security of the system. See the *Intel® Architecture Software Developer's Manual* for more detailed information.

Intel will enable support components for the processor including heatsink, heatsink retention mechanism, and socket. Manufacturability is a high priority; hence, mechanical assembly may be completed from the top of the baseboard and should not require any special tooling.

The processor includes an address bus powerdown capability that removes power from the address and data pins when the FSB is not in use. This feature is always enabled on the processor.

## 1.1 Terminology

A '#' symbol after a signal name refers to an active low signal, indicating a signal is in the active state when driven to a low level. For example, when RESET# is low, a reset has been requested. Conversely, when NMI is high, a nonmaskable interrupt has occurred. In the case of signals where the name does not imply an active state but describes part of a binary sequence (such as *address* or *data*), the '#' symbol implies that the signal is inverted. For example, D[3:0] = 'HLHL' refers to a hex 'A', and D[3:0]# = 'LHLH' also refers to a hex 'A' (H= High logic level, L= Low logic level).

"FSB" refers to the interface between the processor and system core logic (a.k.a. the chipset components). The FSB is a multiprocessing interface to processors, memory, and I/O.

### 1.1.1 Processor Packaging Terminology

Commonly used terms are explained here for clarification:

- **Intel® Celeron® D processor in the 775-land package** — Processor in the FC-LGA4 package with a 256 KB L2 cache.
- **Processor** — For this document, the term "processor" is the generic form of the Celeron D processor in the 775-land package.
- **Keep-out zone** — The area on or near the processor that system design can not use.
- **Intel® 915G\915GV\910GL and 915P\915PL Express chipset** — Chipsets that support DDR and DDR2 memory technology for the Celeron D processor in the 775-land package.
- **Processor core** — Processor core die with integrated L2 cache.
- **FC-LGA4 package** — The Celeron D processor in the 775-land package is available in a Flip-Chip Land Grid Array 4 package, consisting of a processor core mounted on a substrate with an integrated heat spreader (IHS).
- **LGA775 socket** — The Celeron D processor in the 775-land package mates with the system board through a surface mount, 775-land, LGA socket.
- **Integrated heat spreader (IHS)** — A component of the processor package used to enhance the thermal performance of the package. Component thermal solutions interface with the processor at the IHS surface.
- **Retention mechanism (RM)**—Since the LGA775 socket does not include any mechanical features for heatsink attach, a retention mechanism is required. Component thermal solutions should attach to the processor via a retention mechanism that is independent of the socket.
- **Storage conditions**—Refers to a non-operational state. The processor may be installed in a platform, in a tray, or loose. Processors may be sealed in packaging or exposed to free air. Under these conditions, processor lands should not be connected to any supply voltages, have any I/Os biased, or receive any clocks. Upon exposure to "free air" (i.e., unsealed packaging or a device removed from packaging material) the processor must be handled in accordance with moisture sensitivity labeling (MSL) as indicated on the packaging material.
- **Functional operation**—Refers to normal operating conditions in which all processor specifications, including DC, AC, system bus, signal quality, mechanical and thermal, are satisfied.

## 1.2 References

Material and concepts available in the following documents may be beneficial when reading this document.

**Table 1-1. References**

Document	Document Numbers/ Location
<i>Intel® Pentium® 4 Processor on 90 nm Process in the 775-Land LGA Package Thermal Design Guide</i>	<a href="http://developer.intel.com/design/Pentium4/guides/302553.htm">http://developer.intel.com/design/Pentium4/guides/302553.htm</a>
<i>Voltage Regulator Down (VRD) 10.1 Design Guide For Desktop LGA775 Socket</i>	<a href="http://developer.intel.com/design/Pentium4/guides/302356.htm">http://developer.intel.com/design/Pentium4/guides/302356.htm</a>
<i>LGA775 Socket Mechanical Design Guide</i>	<a href="http://developer.intel.com/design/pentium4/guides/302666.htm">http://developer.intel.com/design/pentium4/guides/302666.htm</a>
<i>Intel® Architecture Software Developer's Manual</i> <i>IA-32 Intel® Architecture Software Developer's Manual Volume 1: Basic Architecture</i> <i>IA-32 Intel® Architecture Software Developer's Manual Volume 2A: Instruction Set Reference Manual A–M</i> <i>IA-32 Intel® Architecture Software Developer's Manual Volume 2B: Instruction Set Reference Manual, N–Z</i> <i>IA-32 Intel® Architecture Software Developer's Manual Volume 3: System Programming Guide</i>	<a href="http://developer.intel.com/design/pentium4/manuals/index_new.htm">http://developer.intel.com/design/pentium4/manuals/index_new.htm</a>
<i>IA-32 Intel® Architecture and Intel® Extended Memory 64 Software Developer's Manual Documentation Changes</i>	<a href="http://developer.intel.com/design/pentium4/manuals/index_new.htm">http://developer.intel.com/design/pentium4/manuals/index_new.htm</a>

§



## 2 Electrical Specifications

---

This chapter describes the electrical characteristics of the processor interfaces and signals. DC electrical characteristics are provided.

### 2.1 FSB and GTLREF

Most processor FSB signals use Gunning Transceiver Logic (GTL+) signaling technology. Platforms implement a termination voltage level for GTL+ signals defined as  $V_{TT}$ .  $V_{TT}$  must be provided via a separate voltage source and not be connected to  $V_{CC}$ . This configuration allows for improved noise tolerance as processor frequency increases. Because of the speed improvements to the data and address bus, signal integrity and platform design methods have become more critical than with previous processor families.

The GTL+ inputs require a reference voltage (GTLREF) which is used by the receivers to determine if a signal is a logical 0 or a logical 1. GTLREF must be generated on the system board (see [Table 2-17](#) for GTLREF specifications). Termination resistors are provided on the processor silicon and are terminated to  $V_{TT}$ . Intel chipsets will also provide on-die termination, thus eliminating the need to terminate the bus on the system board for most GTL+ signals.

Some GTL+ signals do not include on-die termination and must be terminated on the system board. See [Table 2-4](#) for details regarding these signals.

The GTL+ bus depends on incident wave switching. Therefore timing calculations for GTL+ signals are based on flight time as opposed to capacitive deratings. Analog signal simulation of the FSB, including trace lengths, is highly recommended when designing a system.

### 2.2 Power and Ground Lands

For clean on-chip power distribution, the Celeron D processor in the 775-land package has 226 VCC (power), 24 VTT and 273 VSS (ground) lands. All power lands must be connected to  $V_{CC}$ , all VTT lands must be connected to  $V_{TT}$ , while all VSS lands must be connected to a system ground plane. The processor VCC lands must be supplied by the voltage determined by the Voltage Identification (VID) signals.

### 2.3 Decoupling Guidelines

Due to its large number of transistors and high internal clock speeds, the processor is capable of generating large current swings between low and full power states. This may cause voltages on power planes to sag below their minimum values if bulk decoupling is not adequate. Care must be taken in the board design to ensure that the voltage provided to the processor remains within the specifications listed in [Table 2-8](#). Failure to do so can result in timing violations or reduced lifetime of the component. For further information, refer to the *Voltage Regulator Down (VRD) 10.1 Design Guide For Desktop LGA775 Socket*.

### 2.3.1 $V_{CC}$ Decoupling

Regulator solutions need to provide bulk capacitance with a low Effective Series Resistance (ESR) and keep a low interconnect resistance from the regulator to the socket. Bulk decoupling for the large current swings when the part is powering on, or entering/exiting low power states, must be provided by the voltage regulator solution (VR). For more details, refer to the *Voltage Regulator Down (VRD) 10.1 Design Guide For Desktop LGA775 Socket*.

### 2.3.2 FSB GTL+ Decoupling

The Celeron D processor in the 775-land package integrates signal termination on the die as well as incorporating high frequency decoupling capacitance on the processor package. Decoupling must also be provided by the system baseboard for proper GTL+ bus operation.

### 2.3.3 FSB Clock (BCLK[1:0]) and Processor Clocking

BCLK[1:0] directly controls the FSB interface speed as well as the core frequency of the processor. As in previous generation processors, the Celeron D processor in the 775-land package core frequency is a multiple of the BCLK[1:0] frequency. Refer to [Table 2-1](#) for the Celeron D processor in the 775-land package supported ratios.

The Celeron D processor in the 775-land package uses a differential clocking implementation. For more information on the Celeron D processor in the 775-land package clocking, refer to the *CK410/CK410M Clock Synthesizer/Driver Specification*.

**Table 2-1. Core Frequency to FSB Multiplier Configuration**

Multiplication of System Core Frequency to FSB Frequency	Processor Number	Core Frequency (133 MHz BCLK / 533 MHz FSB)	Notes <sup>1</sup>
1/19	325J/326	2.53 GHz	—
1/20	330J/331	2.66 GHz	—
1/21	335J/336	2.80 GHz	—
1/22	340J/341	2.93 GHz	—
1/23	345J/346	3.06 GHz	—
1/24	351	3.20 GHz	—
1/25	355	3.33 GHz	—

**NOTES:**

- Individual processors operate only at or below the rated frequency.



## 2.4 Voltage Identification

The VID specification for the Celeron D processor in the 775-land package is supported by the *Voltage Regulator Down (VRD) 10.1 Design Guide For Desktop LGA775 Socket*. The voltage set by the VID signals is the maximum voltage allowed by the processor. A minimum voltage is provided in [Table 2-8](#) and changes with frequency. This allows processors running at a higher frequency to have a relaxed minimum voltage specification. The specifications have been set such that one voltage regulator can work with all supported frequencies.

Individual processor VID values may be calibrated during manufacturing such that two devices at the same speed may have different VID settings.

The Celeron D processor in the 775-land package uses six voltage identification signals, VID[5:0], to support automatic selection of power supply voltages. [Table 2-2](#) specifies the voltage level corresponding to the state of VID[5:0]. A '1' in this table refers to a high voltage level and a '0' refers to low voltage level. If the processor socket is empty (VID[5:0] = x11111), or the voltage regulation circuit cannot supply the voltage that is requested, it must disable itself. See the *Voltage Regulator Down (VRD) 10.1 Design Guide For Desktop LGA775 Socket* for more details.

Power source characteristics must be guaranteed to be stable when the supply to the voltage regulator is stable.

The LL\_ID[1:0] lands are used by the platform to configure the proper loadline slope for the processor. LL\_ID[1:0] = 00 for the Celeron D processor in the 775-land package.

The VTT\_SEL land is used by the platform to configure the proper  $V_{TT}$  voltage level for the processor. VTT\_SEL = 1 for the Celeron D processor in the 775-land package.

The GTLREF\_SEL signal is used by the platform to select the appropriate chipset GTLREF level. GTLREF\_SEL = 0 for the Celeron D processor in the 775-land package.

The VID\_SELECT signal is used by the platform to select the VID table that is to be used by the voltage regulator.

LL\_ID[1:0], VTT\_SEL, GTLREF\_SEL, and VID\_SELECT are signals that are implemented on the processor package. That is they are either connected directly to  $V_{SS}$  or are open lands.

Table 2-2. Voltage Identification Definition

VID5	VID4	VID3	VID2	VID1	VID0	VID
0	0	1	0	1	0	0.8375
1	0	1	0	0	1	0.8500
0	0	1	0	0	1	0.8625
1	0	1	0	0	0	0.8750
0	0	1	0	0	0	0.8875
1	0	0	1	1	1	0.9000
0	0	0	1	1	1	0.9125
1	0	0	1	1	0	0.9250
0	0	0	1	1	0	0.9375
1	0	0	1	0	1	0.9500
0	0	0	1	0	1	0.9625
1	0	0	1	0	0	0.9750
0	0	0	1	0	0	0.9875
1	0	0	0	1	1	1.0000
0	0	0	0	1	1	1.0125
1	0	0	0	1	0	1.0250
0	0	0	0	1	0	1.0375
1	0	0	0	0	1	1.0500
0	0	0	0	0	1	1.0625
1	0	0	0	0	0	1.0750
0	0	0	0	0	0	1.0875
1	1	1	1	1	1	VR output off
0	1	1	1	1	1	VR output off
1	1	1	1	1	0	1.1000
0	1	1	1	1	0	1.1125
1	1	1	1	0	1	1.1250
0	1	1	1	0	1	1.1375
1	1	1	1	0	0	1.1500
0	1	1	1	0	0	1.1625
1	1	1	0	1	1	1.1750
0	1	1	0	1	1	1.1875
1	1	1	0	1	0	1.2000

VID5	VID4	VID3	VID2	VID1	VID0	VID
0	1	1	0	1	0	1.2125
1	1	1	0	0	1	1.2250
0	1	1	0	0	1	1.2375
1	1	1	0	0	0	1.2500
0	1	1	0	0	0	1.2625
1	1	0	1	1	1	1.2750
0	1	0	1	1	1	1.2875
1	1	0	1	1	0	1.3000
0	1	0	1	1	0	1.3125
1	1	0	1	0	1	1.3250
0	1	0	1	0	1	1.3375
1	1	0	1	0	0	1.3500
0	1	0	1	0	0	1.3625
1	1	0	0	1	1	1.3750
0	1	0	0	1	1	1.3875
1	1	0	0	1	0	1.4000
0	1	0	0	1	0	1.4125
1	1	0	0	0	1	1.4250
0	1	0	0	0	1	1.4375
1	1	0	0	0	0	1.4500
0	1	0	0	0	0	1.4625
1	0	1	1	1	1	1.4750
0	0	1	1	1	1	1.4875
1	0	1	1	1	0	1.5000
0	0	1	1	1	0	1.5125
1	0	1	1	0	1	1.5250
0	0	1	1	0	1	1.5375
1	0	1	1	0	0	1.5500
0	0	1	1	0	0	1.5625
1	0	1	0	1	1	1.5750
0	0	1	0	1	1	1.5875
1	0	1	0	1	0	1.6000

## 2.4.1 Phase Lock Loop (PLL) Power and Filter

$V_{CCA}$  and  $V_{CCIOPLL}$  are power sources required by the PLL clock generators for the Celeron D processor in the 775-land package. Since these PLLs are analog, they require low noise power supplies for minimum jitter. Jitter is detrimental to the system: it degrades external I/O timings as well as internal core timings (i.e., maximum frequency). To prevent this degradation, these supplies must be low pass filtered from  $V_{TT}$ .

The AC low-pass requirements, with input at  $V_{TT}$  are as follows:

- < 0.2 dB gain in pass band
- < 0.5 dB attenuation in pass band < 1 Hz
- > 34 dB attenuation from 1 MHz to 66 MHz
- > 28 dB attenuation from 66 MHz to core frequency

The filter requirements are illustrated in Figure 2-1.

**Figure 2-1. Phase Lock Loop (PLL) Filter Requirements**

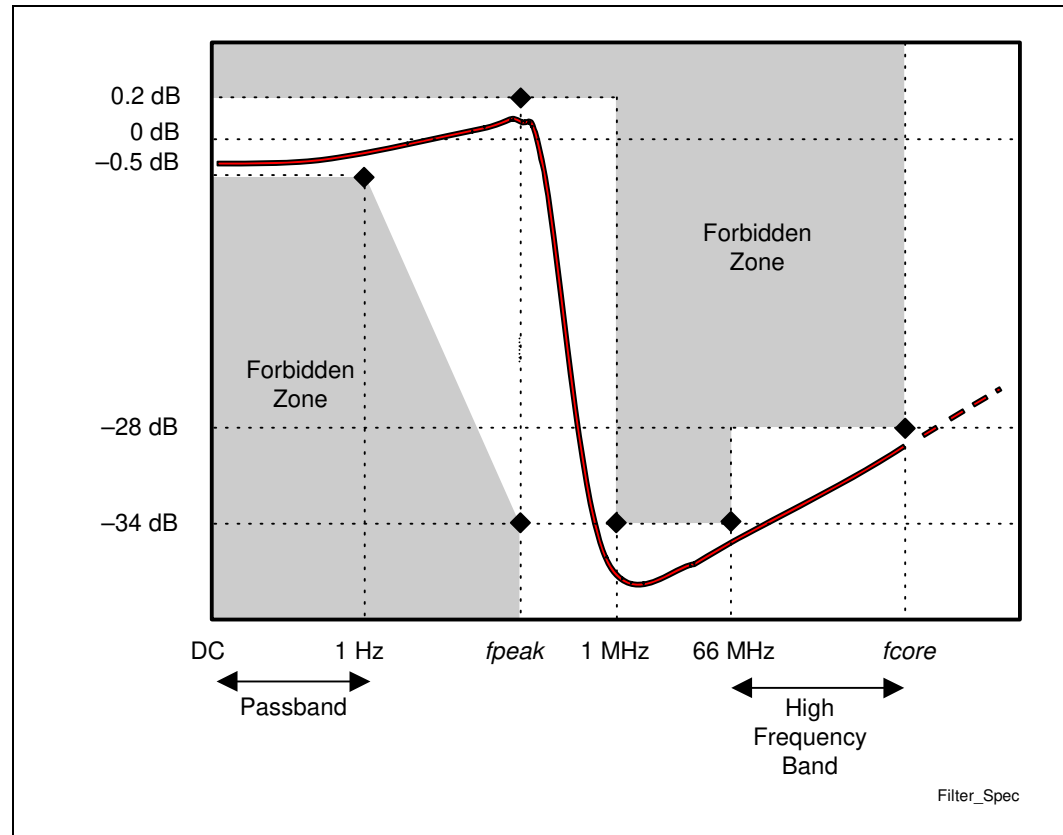

**NOTES:**

1. Diagram not to scale.
2. No specification exists for frequencies beyond  $f_{core}$  (core frequency).
3.  $f_{peak}$ , if existent, should be less than 0.05 MHz.

## 2.5 Reserved, Unused, and TESTHI Signals

All RESERVED signals must remain unconnected. Connection of these signals to  $V_{CC}$ ,  $V_{SS}$ ,  $V_{TT}$ , or to any other signal (including each other) can result in component malfunction or incompatibility with future processors. See [Chapter 4](#) for a land listing of the processor and the location of all RESERVED signals.

For reliable operation, always connect unused inputs or bidirectional signals to an appropriate signal level. In a system level design, on-die termination has been included on the Celeron D processor in the 775-land package to allow signals to be terminated within the processor silicon. Most unused GTL+ inputs should be left as no connects, as GTL+ termination is provided on the processor silicon. However, see [Table 2-4](#) for details on GTL+ signals that do not include on-die termination. Unused active high inputs should be connected through a resistor to ground ( $V_{SS}$ ). Unused outputs can be left unconnected; however, this may interfere with some test access port (TAP) functions, complicate debug probing, and prevent boundary scan testing. A resistor must be used when tying bidirectional signals to power or ground. When tying any signal to power or ground, a resistor will also allow for system testability. For unused GTL+ input or I/O signals, use pull-up resistors of the same value as the on-die termination resistors ( $R_{TT}$ ). Refer to [Table 2-17](#) for more details.

TAP, GTL+ Asynchronous inputs, and GTL+ Asynchronous outputs do not include on-die termination. Inputs and used outputs must be terminated on the system board. Unused outputs may be terminated on the system board or left unconnected. Note that leaving unused outputs unterminated may interfere with some TAP functions, complicate debug probing, and prevent boundary scan testing.

The TESTHI signals must be tied to the processor  $V_{TT}$  using a matched resistor, where a matched resistor has a resistance value within  $\pm 20\%$  of the impedance of the board transmission line traces. For example, if the trace impedance is  $60\ \Omega$ , then a value between  $48\ \Omega$  and  $72\ \Omega$  is required.

The TESTHI signals may use individual pull-up resistors or be grouped together as detailed below. A matched resistor must be used for each group:

- TESTHI[1:0]
- TESTHI[7:2]
- TESTHI8 – cannot be grouped with other TESTHI signals
- TESTHI9 – cannot be grouped with other TESTHI signals
- TESTHI10 – cannot be grouped with other TESTHI signals
- TESTHI11 – cannot be grouped with other TESTHI signals
- TESTHI12 – cannot be grouped with other TESTHI signals
- TESTHI13 – cannot be grouped with other TESTHI signals

## 2.6 FSB Signal Groups

The FSB signals have been combined into groups by buffer type. GTL+ input signals have differential input buffers, which use GTLREF as a reference level. In this document, the term "GTL+ Input" refers to the GTL+ input group as well as the GTL+ I/O group when receiving. Similarly, "GTL+ Output" refers to the GTL+ output group as well as the GTL+ I/O group when driving.

With the implementation of a source synchronous data bus comes the need to specify two sets of timing parameters. One set is for common clock signals which are dependent upon the rising edge of BCLK0 (ADS#, HIT#, HITM#, etc.) and the second set is for the source synchronous signals which are relative to their respective strobe lines (data and address) as well as the rising edge of BCLK0. Asynchronous signals are still present (A20M#, IGNNE#, etc.) and can become active at any time during the clock cycle. [Table 2-3](#) identifies which signals are common clock, source synchronous, and asynchronous.

**Table 2-3. FSB Signal Groups**

Signal Group	Type	Signals <sup>1</sup>														
GTL+ Common Clock Input	Synchronous to BCLK[1:0]	BPRI#, DEFER#, RS[2:0]#, RSP#, TRDY#, EDRDY# <sup>2</sup>														
GTL+ Common Clock I/O	Synchronous to BCLK[1:0]	AP[1:0]#, ADS#, BINIT#, BNR#, BPM[5:0]#, BR0#, DBSY#, DP[3:0]#, DRDY#, HIT#, HITM#, LOCK#, MCERR#														
GTL+ Source Synchronous I/O	Synchronous to assoc. strobe	<table border="0"> <thead> <tr> <th>Signals</th> <th>Associated Strobe</th> </tr> </thead> <tbody> <tr> <td>REQ[4:0]#, A[16:3]#<sup>3</sup> PC_REQ#<sup>2, 4</sup></td> <td>ADSTB0#</td> </tr> <tr> <td>A[35:17]#<sup>3</sup></td> <td>ADSTB1#</td> </tr> <tr> <td>D[15:0]#, DBI0#</td> <td>DSTBP0#, DSTBN0#</td> </tr> <tr> <td>D[31:16]#, DBI1#</td> <td>DSTBP1#, DSTBN1#</td> </tr> <tr> <td>D[47:32]#, DBI2#</td> <td>DSTBP2#, DSTBN2#</td> </tr> <tr> <td>D[63:48]#, DBI3#</td> <td>DSTBP3#, DSTBN3#</td> </tr> </tbody> </table>	Signals	Associated Strobe	REQ[4:0]#, A[16:3]# <sup>3</sup> PC_REQ# <sup>2, 4</sup>	ADSTB0#	A[35:17]# <sup>3</sup>	ADSTB1#	D[15:0]#, DBI0#	DSTBP0#, DSTBN0#	D[31:16]#, DBI1#	DSTBP1#, DSTBN1#	D[47:32]#, DBI2#	DSTBP2#, DSTBN2#	D[63:48]#, DBI3#	DSTBP3#, DSTBN3#
Signals	Associated Strobe															
REQ[4:0]#, A[16:3]# <sup>3</sup> PC_REQ# <sup>2, 4</sup>	ADSTB0#															
A[35:17]# <sup>3</sup>	ADSTB1#															
D[15:0]#, DBI0#	DSTBP0#, DSTBN0#															
D[31:16]#, DBI1#	DSTBP1#, DSTBN1#															
D[47:32]#, DBI2#	DSTBP2#, DSTBN2#															
D[63:48]#, DBI3#	DSTBP3#, DSTBN3#															
GTL+ Strobes	Synchronous to BCLK[1:0]	ADSTB[1:0]#, DSTBP[3:0]#, DSTBN[3:0]#														
GTL+ Asynchronous Input		A20M#, IGNNE#, INIT#, LINT0/INTR, LINT1/NMI, SMI#, STPCLK#, RESET#														
GTL+ Asynchronous Output		FERR#/PBE#, IERR#, THERMTRIP#														
GTL+ Asynchronous Input/Output		PROCHOT#														
TAP Input	Synchronous to TCK	TCK, TDI, TMS, TRST#														
TAP Output	Synchronous to TCK	TDO														
FSB Clock	Clock	BCLK[1:0], ITP_CLK[1:0] <sup>5</sup>														
Power/Other		VCC, VTT, VCCA, VCCIOPLL, VID[7:0], VSS, VSSA, GTLREF[1:0], COMP[5:0], RESERVED, TESTHI[13:0], THERMDA, THERMDC, VCC_SENSE, VSS_SENSE, BSEL[2:0], SKTOCC#, DBR# <sup>5</sup> , VTTTPWRGD, BOOTSELECT, PWRGOOD, VTT_OUT_LEFT, VTT_OUT_RIGHT, VTT_SEL, LL_ID[1:0], VID_SELECT, GTLREF_SEL														

**NOTES:**

1. Refer to [Section 4.2](#) for signal descriptions.
2. EDRDY# and PC\_REQ# are not features of the Celeron D processor in the 775-land package. They are included here for future processor compatibility.
3. The value of these signals during the active-to-inactive edge of RESET# defines the processor configuration options. See [Section 6.1](#) for details.
4. PC\_REQ# is driven by the processor as Common Clock (1X); however, it must be received at the chipset as Source Synchronous and associated with ADSTB0#.
5. In processor systems where there is no debug port implemented on the system board, these signals are used to support a debug port interposer. In systems with the debug port implemented on the system board, these signals are no connects.

Table 2-4. Signal Characteristics

Signals with $R_{TT}$	Signals with no $R_{TT}$
A[35:3]#, ADS#, ADSTB[1:0]#, AP[1:0]#, BINIT#, BNR#, BOOTSELECT <sup>1</sup> , BPRI#, D[63:0]#, DBI[3:0]#, DBSY#, DEFER#, DP[3:0]#, DRDY#, DSTBN[3:0]#, DSTBP[3:0]#, HIT#, HITM#, LOCK#, MCERR#, PROCHOT#, REQ[4:0]#, RS[2:0]#, RSP#, TRDY#, EDRDY# <sup>2</sup> , PC_REQ# <sup>2</sup>	A20M#, BCLK[1:0], BPM[5:0]#, BR0#, BSEL[2:0], COMP[5:0], FERR#/PBE#, IERR#, IGNNE#, INIT#, LINT0/INTR, LINT1/NMI, PWRGOOD, RESET#, SKTOCC#, SMI#, STPCLK#, TDO, TESTHI[13:0], THERMDA, THERMDC, THERMTRIP#, VID[5:0], VTT_PWRGD, GTLREF[1:0], TCK, TDI, TRST#, TMS
Open Drain Signals <sup>3</sup>	
BSEL[2:0], VID[7:0], THERMTRIP#, FERR#/PBE#, IERR#, BPM[5:0]#, BR0#, TDO, VTT_SEL, LL_ID[1:0], MS_ID[1:0], GTLREF_SEL, VID_SELECT	

**NOTES:**

1. The BOOTSELECT signal has a 500–5000  $\Omega$  pull-up to  $V_{TT}$  rather than on-die termination.
2. EDRDY# and PC\_REQ# are not features of the Celeron D processor in the 775-land package. They are included here for future processor compatibility.
3. Signals that do not have  $R_{TT}$ , nor are actively driven to their high-voltage level.

Table 2-5. Signal Reference Voltages

GTLREF	$V_{TT}/2$
BPM[5:0]#, LINT0/INTR, LINT1/NMI, RESET#, BINIT#, BNR#, HIT#, HITM#, MCERR#, PROCHOT#, BR0#, A[35:0]#, ADS#, ADSTB[1:0]#, AP[1:0]#, BPRI#, D[63:0]#, DBI[3:0]#, DBSY#, DEFER#, DP[3:0]#, DRDY#, DSTBN[3:0]#, DSTBP[3:0]#, LOCK#, REQ[4:0]#, RS[2:0]#, RSP#, TRDY#, EDRDY# <sup>1</sup> , PC_REQ# <sup>1</sup>	BOOTSELECT, VTT_PWRGD, A20M#, IGNNE#, INIT#, PWRGOOD <sup>2</sup> , SMI#, STPCLK#, TCK <sup>2</sup> , TDI <sup>2</sup> , TMS <sup>2</sup> , TRST# <sup>2</sup>

**NOTES:**

1. EDRDY# and PC\_REQ# are not features of the Celeron D processor in the 775-land package. They are included here for future processor compatibility.
2. These signals also have hysteresis added to the reference voltage. See Table 2-12 for more information.

## 2.7 GTL+ Asynchronous Signals

Legacy input signals such as A20M#, IGNNE#, INIT#, SMI#, and STPCLK# use CMOS input buffers. All of these signals follow the same DC requirements as GTL+ signals; however, the outputs are not actively driven high (during a logical 0 to 1 transition) by the processor. These signals do not have setup or hold time specifications in relation to BCLK[1:0].

All of the GTL+ Asynchronous signals are required to be asserted/de-asserted for at least six BCLKs for the processor to recognize the proper signal state. See Section 2.11 for the DC specifications for the GTL+ Asynchronous signal groups. See Section 6.2 for additional timing requirements for entering and leaving the low power states.

## 2.8 Test Access Port (TAP) Connection

Due to the voltage levels supported by other components in the Test Access Port (TAP) logic, it is recommended that the Celeron D processor in the 775-land package be first in the TAP chain and followed by any other components within the system. A translation buffer should be used to connect to the rest of the chain unless one of the other components is capable of accepting an input of the appropriate voltage level. Similar considerations must be made for TCK, TMS, TRST#, TDI, and TDO. Two copies of each signal may be required, with each driving a different voltage level.

## 2.9 FSB Frequency Select Signals (BSEL[2:0])

The BSEL[2:0] signals are used to select the frequency of the processor input clock (BCLK[1:0]). [Table 2-6](#) defines the possible combinations of the signals and the frequency associated with each combination. The required frequency is determined by the processor, chipset, and clock synthesizer. All agents must operate at the same frequency.

The Celeron D processor in the 775-land package currently operates at a 533 MHz FSB frequency (selected by a 133 MHz BCLK[1:0] frequency). Individual processors will only operate at their specified FSB frequency.

For more information about these signals, refer to [Section 4.2](#).

**Table 2-6. BSEL[2:0] Frequency Table for BCLK[1:0]**

BSEL2	BSEL1	BSEL0	FSB Frequency
L	L	L	Reserved
L	L	H	133 MHz
L	H	H	Reserved
L	H	L	Reserved
H	L	L	Reserved
H	L	H	Reserved
H	H	H	Reserved
H	H	L	Reserved

## 2.10 Absolute Maximum and Minimum Ratings

[Table 2-7](#) specifies absolute maximum and minimum ratings. Within functional operation limits, functionality and long-term reliability can be expected.

At conditions outside functional operation condition limits, but within absolute maximum and minimum ratings, neither functionality nor long-term reliability can be expected. If a device is returned to conditions within functional operation limits after having been subjected to conditions outside these limits, but within the absolute maximum and minimum ratings, the device may be functional, but with its lifetime degraded depending on exposure to conditions exceeding the functional operation condition limits.

At conditions exceeding absolute maximum and minimum ratings, neither functionality nor long-term reliability can be expected. Moreover, if a device is subjected to these conditions for any length of time then, when returned to conditions within the functional operating condition limits, it will either not function, or its reliability will be severely degraded.

Although the processor contains protective circuitry to resist damage from static electric discharge, precautions should always be taken to avoid high static voltages or electric fields.

**Table 2-7. Processor DC Absolute Maximum Ratings**

Symbol	Parameter	Min	Max	Unit	Notes <sup>1, 2</sup>
V <sub>CC</sub>	Core voltage with respect to V <sub>SS</sub>	- 0.3	1.55	V	—
V <sub>TT</sub>	FSB termination voltage with respect to V <sub>SS</sub>	- 0.3	1.55	V	—
T <sub>C</sub>	Processor case temperature	See <a href="#">Chapter 5</a>	See <a href="#">Chapter 5</a>	°C	—
T <sub>STORAGE</sub>	Processor storage temperature	-40	+85	°C	3, 4

**NOTES:**

- For functional operation, all processor electrical, signal quality, mechanical and thermal specifications must be satisfied.
- Excessive overshoot or undershoot on any signal will likely result in permanent damage to the processor.
- Storage temperature is applicable to storage conditions only. In this scenario, the processor must not receive a clock, and no lands can be connected to a voltage bias. Storage within these limits will not affect the long-term reliability of the device. For functional operation, refer to the processor case temperature specifications.
- This rating applies to the processor and does not include any tray or packaging.

## 2.11 Processor DC Specifications

**The processor DC specifications in this section are defined at the processor core silicon and not at the package lands unless noted otherwise.** See [Chapter 4](#) for the signal definitions and signal assignments. Most of the signals on the processor FSB are in the GTL+ signal group. The DC specifications for these signals are listed in [Table 2-11](#).

Previously, legacy signals and Test Access Port (TAP) signals to the processor used low-voltage CMOS buffer types. However, these interfaces now follow DC specifications similar to GTL+. The DC specifications for these signal groups are listed in [Table 2-10](#) and [Table 2-12](#).

[Table 2-8](#) through [Table 2-14](#) list the DC specifications for the Celeron D processor in the 775-land package and are valid only while meeting specifications for case temperature, clock frequency, and input voltages. Care should be taken to read all notes associated with each parameter.

### 2.11.1 Processor DC Specifications

**The processor DC specifications in this section are defined at the processor core silicon and not at the package lands unless noted otherwise.** See [Chapter 4](#) for the signal definitions and signal assignments. Most of the signals on the processor FSB are in the GTL+ signal group. The DC specifications for these signals are listed in [Table 2-10](#).

[Table 2-8](#) through [Table 2-15](#) list the DC specifications for the Celeron D processor in the 775-land package and are valid only while meeting specifications for case temperature, clock frequency, and input voltages. Care should be taken to read all notes associated with each parameter.



**Table 2-8. Voltage and Current Specifications**

Symbol	Parameter		Min	Typ	Max	Unit	Notes
VID range	VID		1.250	—	1.400	V	1
V <sub>CC</sub>	Processor Number	Core Frequency					
	325J/326	2.53 GHz	Refer to <a href="#">Table 2-9</a> and <a href="#">Figure 2-2</a>				
	330J/331	2.66 GHz					
	335J/336	2.80 GHz					
	340J/341	2.93 GHz					
	345J/346	3.06 GHz					
	351	3.20 GHz					
355	3.33 GHz				V	2, 3, 4, 5, 6	
I <sub>CC</sub>	Processor Number	Core Frequency					
	325J/326	2.53 GHz	I <sub>CC</sub> for processor with multiple VID				
	330J/331	2.66 GHz					
	335J/336	2.80 GHz					
	340J/341	2.93 GHz					
	345J/346	3.06 GHz					
	351	3.20 GHz					
355	3.33 GHz	—	—	78	A	7	
I <sub>SGNT</sub>	Processor Number	Core Frequency					
	325J/326	2.53 GHz	I <sub>CC</sub> Stop-Grant				
	330J/331	2.66 GHz					
	335J/336	2.80 GHz					
	340J/341	2.93 GHz					
	345J/346	3.06 GHz					
	351	3.20 GHz					
355	3.33 GHz	—	—	40	A	8, 9, 13	
I <sub>TCC</sub>	I <sub>CC</sub> TCC active		—	—	I <sub>CC</sub>	A	10
V <sub>TT</sub>	FSB termination voltage (DC+AC specifications)		1.14	1.20	1.26	V	11, 12
V <sub>TT_OUT</sub> I <sub>CC</sub>	DC Current that may be drawn from V <sub>TT_OUT</sub> per pin		—	—	580	mA	—
I <sub>TT</sub>	FSB termination current		—	—	3.5	A	13, 14
I <sub>CC_VCCA</sub>	I <sub>CC</sub> for PLL lands		—	—	120	mA	13
I <sub>CC_VCCIOPLL</sub>	I <sub>CC</sub> for I/O PLL land		—	—	100	mA	13
I <sub>CC_GTLREF</sub>	I <sub>CC</sub> for GTLREF		—	—	200	μA	13

**NOTES:**

- Individual processor VID values may be calibrated during manufacturing such that two devices at the same speed may have different VID settings.

2. These voltages are targets only. A variable voltage source should exist on systems in the event that a different voltage is required. See [Section 2.4](#) and [Table 2-2](#) for more information.
3. The voltage specification requirements are measured across VCC\_SENSE and VSS\_SENSE lands at the socket with a 100 MHz bandwidth oscilloscope, 1.5 pF maximum probe capacitance, and 1 MΩ minimum impedance. The maximum length of ground wire on the probe should be less than 5 mm. Ensure external noise from the system is not coupled into the oscilloscope probe.
4. 775\_VR\_CONFIG\_04A refers to voltage regulator configurations that are defined in the *Voltage Regulator Down (VRD) 10.1 Design Guide For Desktop LGA775 Socket*.
5. Refer to [Table 2-9](#) and [Figure 2-2](#) for the minimum, typical, and maximum V<sub>CC</sub> allowed for a given current. The processor should not be subjected to any V<sub>CC</sub> and I<sub>CC</sub> combination wherein V<sub>CC</sub> exceeds V<sub>CC,max</sub> for a given current.
6. These frequencies will operate properly in a system designed for 775\_VR\_CONFIG\_04B processors. The power and I<sub>CC</sub> will be incrementally higher in this configuration due to the improved loadline and resulting higher V<sub>CC</sub>.
7. I<sub>CC,max</sub> is specified at V<sub>CC,max</sub>.
8. The current specified is also for AutoHALT State.
9. I<sub>CC</sub> Stop-Grant and I<sub>CC</sub> Sleep are specified at V<sub>CC,max</sub>.
10. The maximum instantaneous current the processor will draw while the thermal control circuit is active as indicated by the assertion of PROCHOT# is the same as the maximum I<sub>CC</sub> for the processor.
11. VTT must be provided via a separate voltage source and not be connected to V<sub>CC</sub>. This specification is measured at the land.
12. Baseboard bandwidth is limited to 20 MHz.
13. These parameters are based on design characterization and are not tested.
14. This is maximum total current drawn from V<sub>TT</sub> plane by only the processor. This specification does not include the current coming from R<sub>TT</sub> (through the signal line). Refer to the *Voltage Regulator Down (VRD) 10.1 Design Guide For Desktop LGA775 Socket* to determine the total I<sub>TT</sub> drawn by the system.

**Table 2-9. V<sub>CC</sub> Static and Transient Tolerance for 775\_VR\_CONFIG\_04A Processors**

I <sub>CC</sub> (A)	Voltage Deviation from VID Setting (V) <sup>1, 2, 3</sup>		
	Maximum Voltage 1.70 mΩ	Typical Voltage 1.75 mΩ	Minimum Voltage 1.80 mΩ
0	0.000	-0.025	-0.050
5	-0.009	-0.034	-0.059
10	-0.017	-0.043	-0.068
15	-0.026	-0.051	-0.077
20	-0.034	-0.060	-0.086
25	-0.043	-0.069	-0.095
30	-0.051	-0.078	-0.104
35	-0.060	-0.086	-0.113
40	-0.068	-0.095	-0.122
45	-0.077	-0.104	-0.131
50	-0.085	-0.113	-0.140
55	-0.094	-0.121	-0.149
60	-0.102	-0.130	-0.158
65	-0.111	-0.139	-0.167
70	-0.119	-0.148	-0.176
75	-0.128	-0.156	-0.185
78	-0.133	-0.162	-0.190

**NOTES:**

1. The loadline specification includes both static and transient limits except for overshoot allowed as shown in [Section 2.12](#).
2. This table is intended to aid in reading discrete points on [Figure 2-2](#).
3. The loadlines specify voltage limits at the die measured at the VCC\_SENSE and VSS\_SENSE lands. Voltage regulation feedback for voltage regulator circuits must be taken from processor VCC and VSS lands. Refer to the *Voltage Regulator Down (VRD) 10.1 Design Guide For Desktop LGA775 Socket* for socket loadline guidelines and VR implementation details.

Figure 2-2.  $V_{CC}$  Static and Transient Tolerance for 775\_VR\_CONFIG\_04A

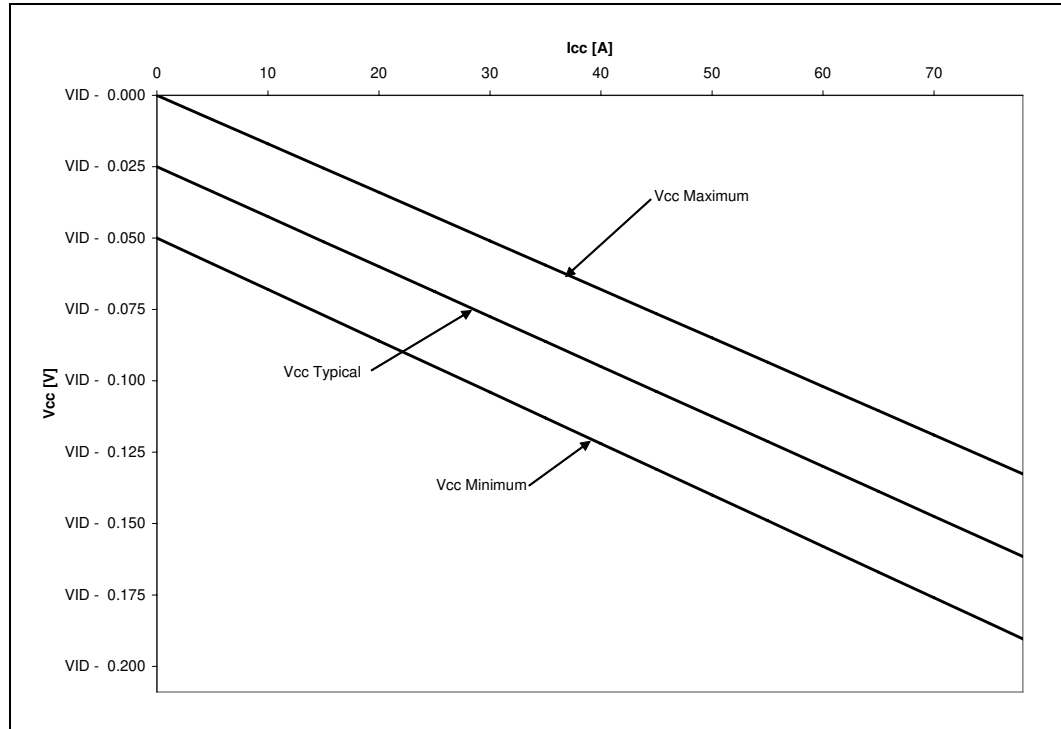

**NOTES:**

1. The loadline specification includes both static and transient limits except for overshoot allowed as shown in [Section 2.12](#).
2. This loadline specification shows the deviation from the VID set point.
3. The loadlines specify voltage limits at the die measured at the VCC\_SENSE and VSS\_SENSE lands. Voltage regulation feedback for voltage regulator circuits must be taken from processor VCC and VSS lands. Refer to the *Voltage Regulator Down (VRD) 10.1 Design Guide For Desktop LGA775 Socket* for socket loadline guidelines and VR implementation details.

Table 2-10. GTL+ Asynchronous Signal Group DC Specifications

Symbol	Parameter	Min	Max	Unit	Notes <sup>1</sup>
V <sub>IL</sub>	Input Low Voltage	0.0	$V_{TT}/2 - (0.10 * V_{TT})$	—	2, 3
V <sub>IH</sub>	Input High Voltage	$V_{TT}/2 + (0.10 * V_{TT})$	V <sub>TT</sub>	—	3, 4, 5, 6
V <sub>OH</sub>	Output High Voltage	0.90*V <sub>TT</sub>	V <sub>TT</sub>	V	5, 6, 7
I <sub>OL</sub>	Output Low Current	—	$V_{TT}/[(0.50 * R_{TT\_MIN}) + R_{ON\_MIN}]$	A	8
I <sub>LI</sub>	Input Leakage Current	N/A	± 200	μA	9
I <sub>LO</sub>	Output Leakage Current	N/A	± 200	μA	10
R <sub>ON</sub>	Buffer On Resistance	8	12	Ω	

**NOTES:**

- Unless otherwise noted, all specifications in this table apply to all processor frequencies.
- V<sub>IL</sub> is defined as the voltage range at a receiving agent that will be interpreted as a logical low value.
- LINT0/INTR and LINT1/NMI use GTLREF as a reference voltage. For these two signals V<sub>IH</sub> = GTLREF + (0.10 \* V<sub>TT</sub>) and V<sub>IL</sub> = GTLREF - (0.10 \* V<sub>TT</sub>).
- V<sub>IH</sub> is defined as the voltage range at a receiving agent that will be interpreted as a logical high value.
- V<sub>IH</sub> and V<sub>OH</sub> may experience excursions above V<sub>TT</sub>.
- The V<sub>TT</sub> referred to in these specifications refers to instantaneous V<sub>TT</sub>.
- All outputs are open drain.
- The maximum output current is based on maximum current handling capability of the buffer and is not specified into the test load.
- Leakage to V<sub>SS</sub> with land held at V<sub>TT</sub>.
- Leakage to V<sub>TT</sub> with land held at 300 mV.

Table 2-11. GTL+ Signal Group DC Specifications

Symbol	Parameter	Min	Max	Unit	Notes <sup>1</sup>
V <sub>IL</sub>	Input Low Voltage	0.0	GTLREF - (0.10 * V <sub>TT</sub> )	V	2, 3
V <sub>IH</sub>	Input High Voltage	GTLREF + (0.10 * V <sub>TT</sub> )	V <sub>TT</sub>	V	3, 4, 5
V <sub>OH</sub>	Output High Voltage	0.90*V <sub>TT</sub>	V <sub>TT</sub>	V	3, 5
I <sub>OL</sub>	Output Low Current	N/A	$V_{TT}/[(0.50 * R_{TT\_MIN}) + R_{ON\_MIN}]$	A	-
I <sub>LI</sub>	Input Leakage Current	N/A	± 200	μA	6
I <sub>LO</sub>	Output Leakage Current	N/A	± 200	μA	6
R <sub>ON</sub>	Buffer On Resistance	8	12	Ω	

**NOTES:**

- Unless otherwise noted, all specifications in this table apply to all processor frequencies.
- V<sub>IL</sub> is defined as the voltage range at a receiving agent that will be interpreted as a logical low value.
- The V<sub>TT</sub> referred to in these specifications is the instantaneous V<sub>TT</sub>.
- V<sub>IH</sub> is defined as the voltage range at a receiving agent that will be interpreted as a logical high value.
- V<sub>IH</sub> and V<sub>OH</sub> may experience excursions above V<sub>TT</sub>.
- Leakage to V<sub>SS</sub> with land held at V<sub>TT</sub>.

**Table 2-12. PWRGOOD and TAP Signal Group DC Specifications**

Symbol	Parameter	Min	Max	Unit	Notes <sup>1, 2</sup>
V <sub>HYS</sub>	Input Hysteresis	200	350	mV	3
V <sub>T+</sub>	Input low to high threshold voltage	0.5 * (V <sub>TT</sub> + V <sub>HYS_MIN</sub> )	0.5 * (V <sub>TT</sub> + V <sub>HYS_MAX</sub> )	V	4
V <sub>T-</sub>	Input high to low threshold voltage	0.5 * (V <sub>TT</sub> - V <sub>HYS_MAX</sub> )	0.5 * (V <sub>TT</sub> - V <sub>HYS_MIN</sub> )	V	4
V <sub>OH</sub>	Output High Voltage	N/A	V <sub>TT</sub>	V	4
I <sub>OL</sub>	Output Low Current	—	45	mA	5
I <sub>LI</sub>	Input Leakage Current	—	± 200	μA	6
I <sub>LO</sub>	Output Leakage Current	—	± 200	μA	6
R <sub>ON</sub>	Buffer On Resistance	7	12	Ω	

**NOTES:**

1. Unless otherwise noted, all specifications in this table apply to all processor frequencies.
2. All outputs are open drain.
3. V<sub>HYS</sub> represents the amount of hysteresis, nominally centered about 0.5 \* V<sub>TT</sub>, for all TAP inputs.
4. The V<sub>TT</sub> referred to in these specifications refers to instantaneous V<sub>TT</sub>.
5. The maximum output current is based on maximum current handling capability of the buffer and is not specified into the test load.
6. Leakage to V<sub>SS</sub> with land held at V<sub>TT</sub>.

**Table 2-13. VTPWRGD DC Specifications**

Symbol	Parameter	Min	Typ	Max	Unit	Notes
V <sub>IL</sub>	Input Low Voltage	—	—	0.3	V	
V <sub>IH</sub>	Input High Voltage	0.9	—	—	V	

**Table 2-14. BSEL [2:0] and VID[5:0] DC Specifications**

Symbol	Parameter	Max	Unit	Notes <sup>1, 2</sup>
R <sub>ON</sub> (BSEL)	Buffer On Resistance	60	Ω	—
R <sub>ON</sub> (VID)	Buffer On Resistance	60	Ω	—
I <sub>OL</sub>	Max Land Current	8	mA	—
I <sub>LO</sub>	Output Leakage Current	200	μA	3
V <sub>TOL</sub>	Voltage Tolerance	V <sub>TT</sub> (max)	V	—

**NOTES:**

1. Unless otherwise noted, all specifications in this table apply to all processor frequencies.
2. These parameters are not tested and are based on design simulations.
3. Leakage to V<sub>SS</sub> with land held at 2.5 V.

**Table 2-15. BOOTSELECT DC Specifications**

Symbol	Parameter	Min	Typ	Max	Unit	Notes
V <sub>IL</sub>	Input Low Voltage	—	—	0.24	V	1
V <sub>IH</sub>	Input High Voltage	0.96	—	—	V	—

**NOTES:**

1. These parameters are not tested and are based on design simulations.

## 2.12 V<sub>CC</sub> Overshoot Specification

The Celeron D processor in the 775-land package can tolerate short transient overshoot events where V<sub>CC</sub> exceeds the VID voltage when transitioning from a high to low current load condition. This overshoot cannot exceed VID + V<sub>OS\_MAX</sub> (V<sub>OS\_MAX</sub> is the maximum allowable overshoot voltage). The time duration of the overshoot event must not exceed T<sub>OS\_MAX</sub> (T<sub>OS\_MAX</sub> is the maximum allowable time duration above VID). These specifications apply to the processor die voltage as measured across the VCC\_SENSE and VSS\_SENSE lands.

Table 2-16. V<sub>CC</sub> Overshoot Specifications

Symbol	Parameter	Min	Typ	Max	Unit	Figure
V <sub>OS_MAX</sub>	Magnitude of V <sub>CC</sub> overshoot above VID	—	—	0.050	V	2-3
T <sub>OS_MAX</sub>	Time duration of V <sub>CC</sub> overshoot above VID	—	—	25	μs	2-3

Figure 2-3. V<sub>CC</sub> Overshoot Example Waveform

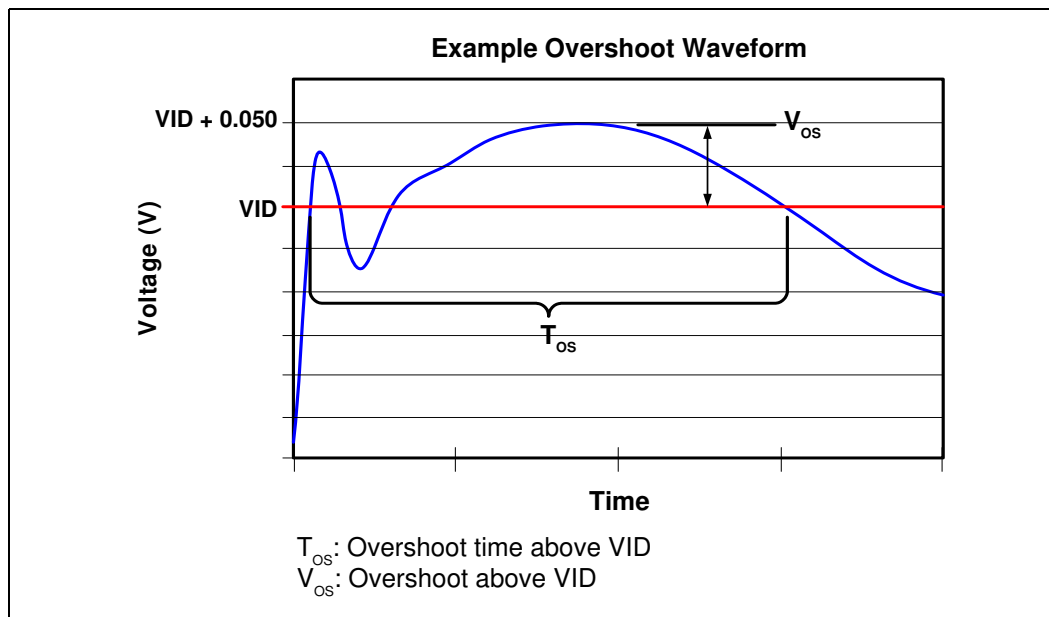

**NOTES:**

1. V<sub>OS</sub> is measured overshoot voltage.
2. T<sub>OS</sub> is measured time duration above VID.

### 2.12.1 Die Voltage Validation

Overshoot events from application testing on real processors must meet the specifications in Table 2-16 when measured across the VCC\_SENSE and VSS\_SENSE lands. Overshoot events that are < 10 ns in duration may be ignored. These measurements of processor die level overshoot should be taken with a 100 MHz bandwidth limited oscilloscope. Refer to the *Voltage Regulator Down (VRD) 10.1 Design Guide For Desktop LGA775 Socket* for additional voltage regulator validation details.

## 2.13 GTL+ FSB Specifications

Termination resistors are not required for most GTL+ signals, as these are integrated into the processor silicon.

Valid high and low levels are determined by the input buffers which compare a signal's voltage with a reference voltage called GTLREF.

Table 2-17 lists the GTLREF specifications. The GTL+ reference voltage (GTLREF) should be generated on the system board using high precision voltage divider circuits.

**Table 2-17. GTL+ Bus Voltage Definitions**

Symbol	Parameter	Min	Typ	Max	Units	Notes <sup>1</sup>
GTLREF	Bus Reference Voltage	$(0.98 * 0.67) * V_{TT}$	$0.67 * V_{TT}$	$(1.02 * 0.67) * V_{TT}$	V	2, 3, 4
R <sub>PULLUP</sub>	On die pullup for BOOTSELECT signal	500	—	5000	Ω	5
R <sub>TT</sub>	Termination Resistance	54	60	66	Ω	6
COMP[1:0]	COMP Resistance	59.8	60.4	61	Ω	7
COMP[3:2]	COMP Resistance	99	100	101	Ω	7
COMP[5:4]	COMP Resistance	59.8	60.4	61	Ω	7

**NOTES:**

1. Unless otherwise noted, all specifications in this table apply to all processor frequencies.
2. The tolerances for this specification have been stated generically to enable the system designer to calculate the minimum and maximum values across the range of  $V_{TT}$ .
3. GTLREF should be generated from  $V_{TT}$  by a voltage divider of 1% resistors or 1% matched resistors.
4. The  $V_{TT}$  referred to in these specifications is the instantaneous  $V_{TT}$ .
5. These pull-ups are to  $V_{TT}$ .
6.  $R_{TT}$  is the on-die termination resistance measured at  $V_{TT}/2$  of the GTL+ output driver.
7. COMP resistance must be provided on the system board with 1% resistors. COMP[1:0] resistors are to  $V_{SS}$ . COMP[3:2] resistors are to  $V_{TT}$ . COMP[5:4] resistors are to  $V_{TT}$ .

§





## 3 Package Mechanical Specifications

The Celeron D processor in the 775-land package is packaged in a Flip-Chip Land Grid Array (FC-LGA4) package that interfaces with the motherboard via an LGA775 socket. The package consists of a processor core mounted on a substrate land-carrier. An integrated heat spreader (IHS) is attached to the package substrate and core and serves as the mating surface for processor component thermal solutions, such as a heatsink. Figure 3-1 shows a sketch of the processor package components and how they are assembled together. Refer to the *LGA775 Socket Mechanical Design Guide* for complete details on the LGA775 socket.

The package components shown in Figure 3-1 include the following:

- Integrated Heat Spreader (IHS)
- Thermal Interface Material (TIM)
- Processor core (die)
- Package substrate
- Capacitors

Figure 3-1. Processor Package Assembly Sketch

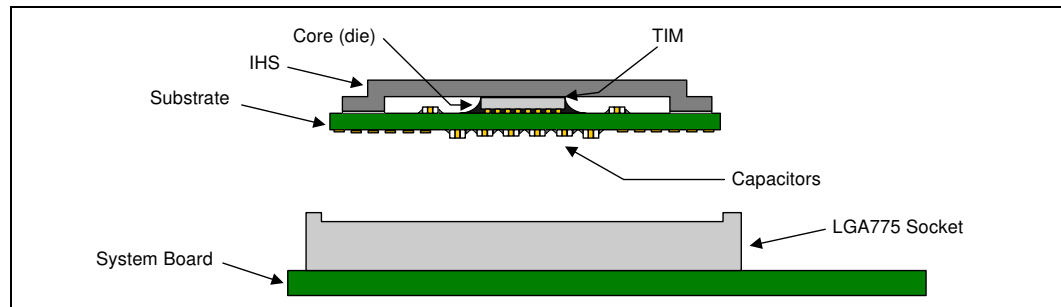

**NOTE:**

1. Socket and motherboard are included for reference and are not part of processor package.

### 3.1 Package Mechanical Drawing

The package mechanical drawings are shown in Figure 3-2 through Figure 3-4. The drawings include dimensions necessary to design a thermal solution for the processor. These dimensions include:

- Package reference with tolerances (total height, length, width, etc.)
- IHS parallelism and tilt
- Land dimensions
- Top-side and back-side component keep-out dimensions
- Reference datums

All drawing dimensions are in mm [in].

Figure 3-2. Processor Package Drawing 1

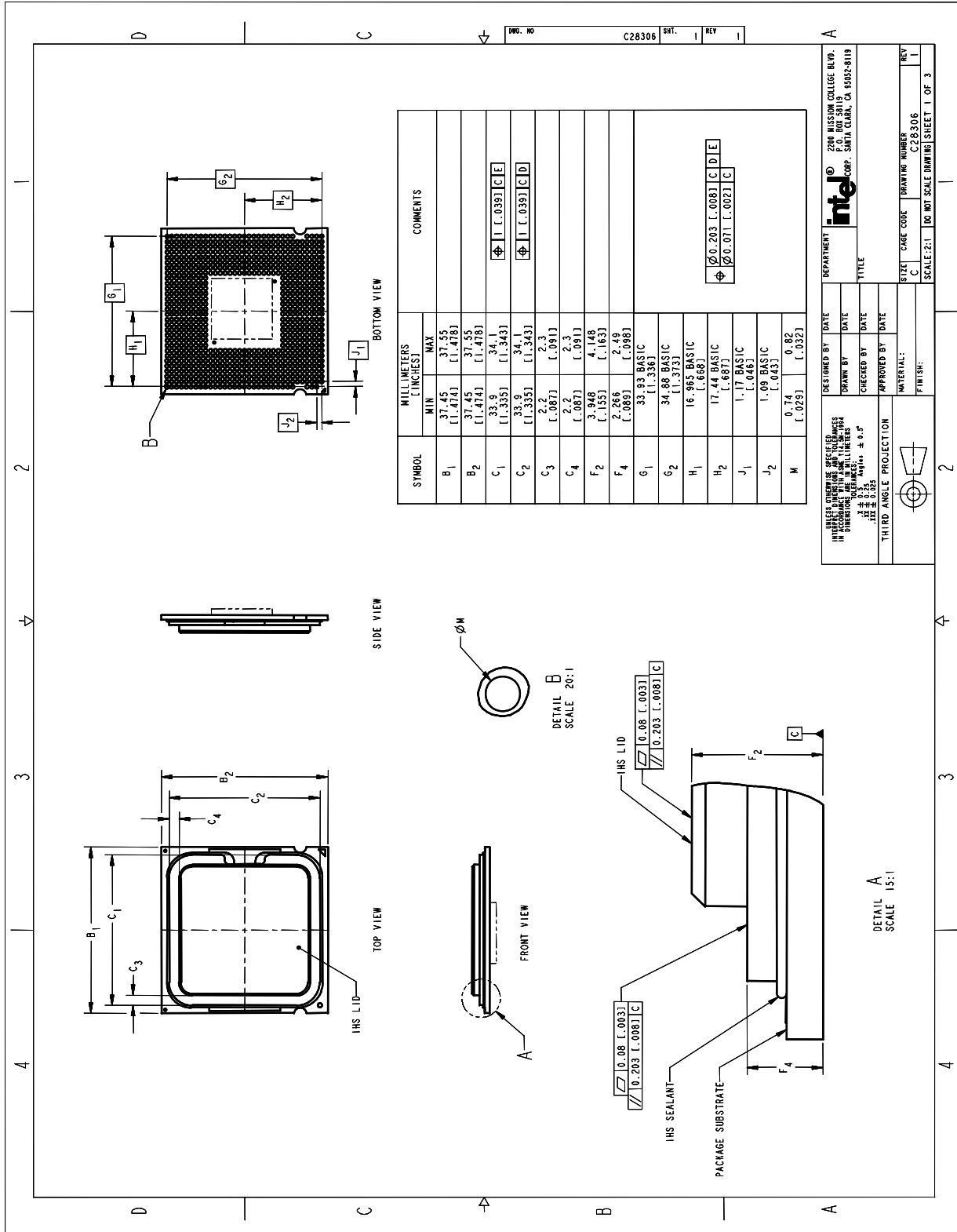

Figure 3-3. Processor Package Drawing 2

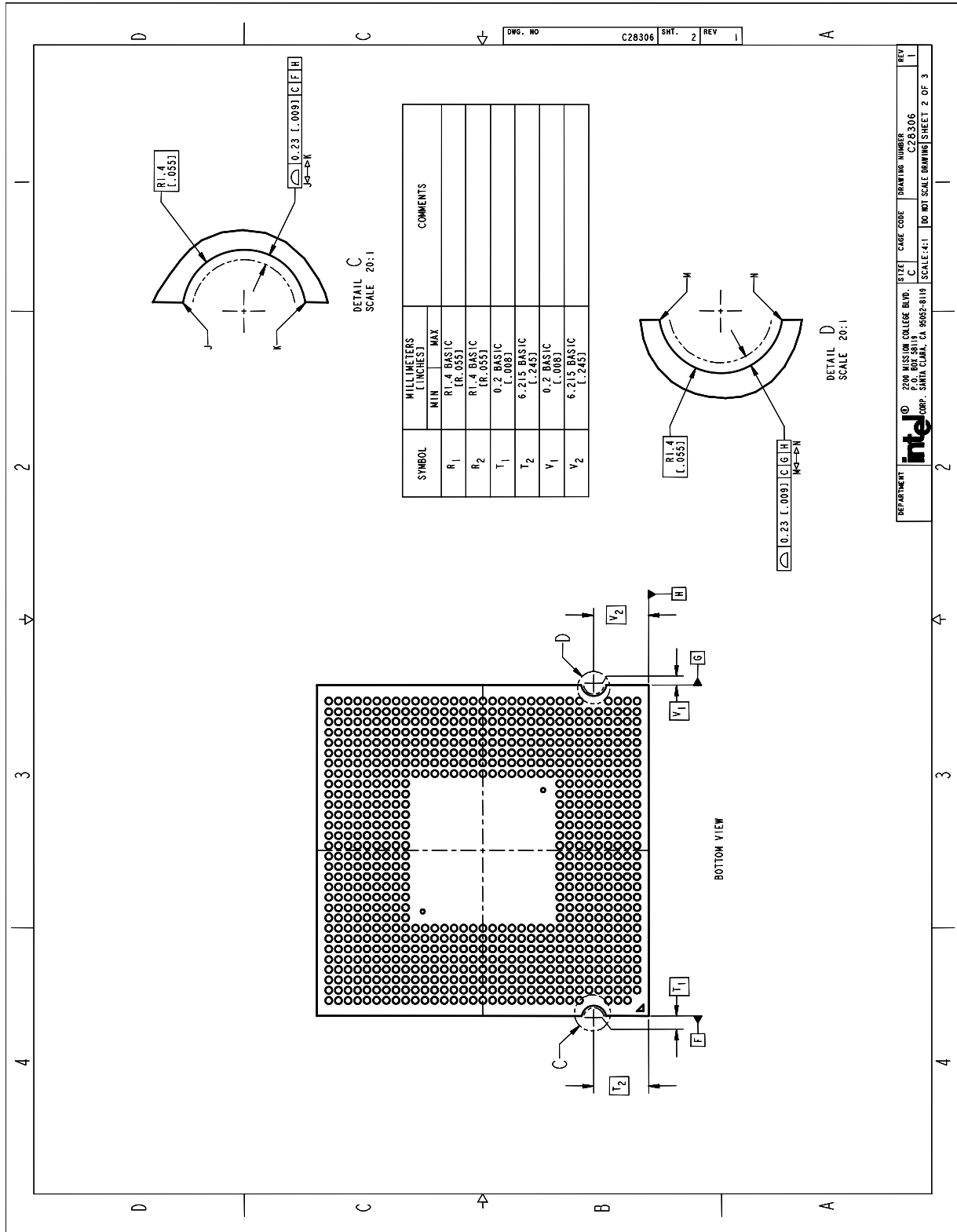
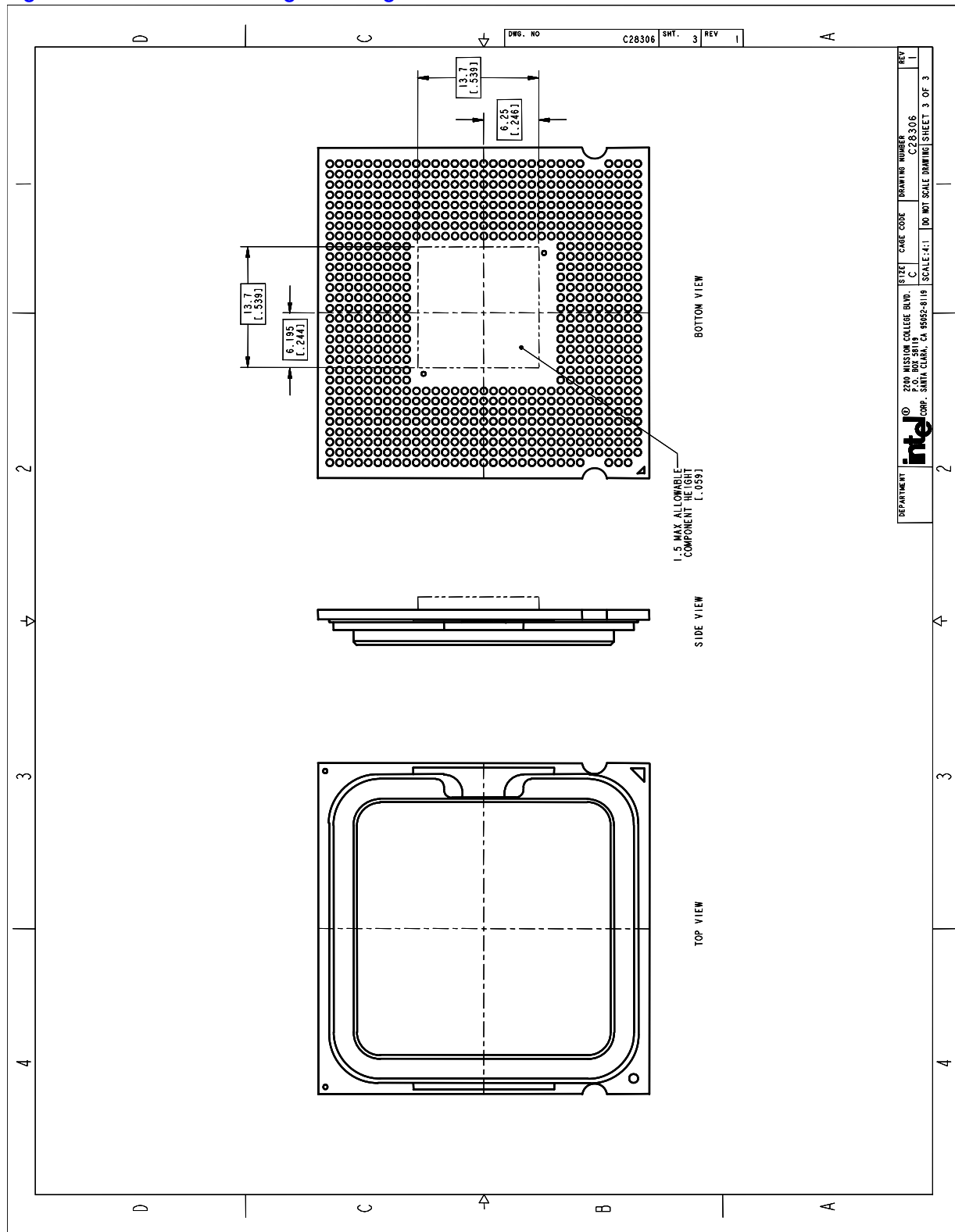

Figure 3-4. Processor Package Drawing 3



### 3.2 Processor Component Keep-Out Zones

The processor may contain components on the substrate that define component keep-out zone requirements. A thermal and mechanical solution design must not intrude into the required keep-out zones. Decoupling capacitors are typically mounted to either the topside or land-side of the package substrate. See [Figure 3-2](#) and [Figure 3-3](#) for keep-out zones.

The location and quantity of package capacitors may change due to manufacturing efficiencies but will remain within the component keep-in.

### 3.3 Package Loading Specifications

[Table 3-1](#) provides dynamic and static load specifications for the processor package. These mechanical maximum load limits should not be exceeded during heatsink assembly, shipping conditions, or standard use condition. Also, any mechanical system or component testing should not exceed the maximum limits. The processor package substrate should not be used as a mechanical reference or load-bearing surface for thermal and mechanical solution. The minimum loading specification must be maintained by any thermal and mechanical solutions.

**Table 3-1. Processor Loading Specifications**

Parameter	Minimum	Maximum	Notes
Static	20 lbf	45 lbf	1, 2, 3
Dynamic	—	145 lbf	1, 3, 4

**NOTES:**

1. These specifications apply to uniform compressive loading in a direction normal to the processor IHS.
2. This is the maximum force that can be applied by a heatsink retention clip. The clip must also provide the minimum specified load on the processor package.
3. These specifications are based on limited testing for design characterization. Loading limits are for the package only and do not include the limits of the processor socket.
4. Dynamic loading is defined as an 11 ms duration average load superimposed on the static load requirement.

### 3.4 Package Handling Guidelines

[Table 3-2](#) includes a list of guidelines on package handling in terms of recommended maximum loading on the processor IHS relative to a fixed substrate. These package handling loads may be experienced during heatsink removal.

**Table 3-2. Package Handling Guidelines**

Parameter	Maximum Recommended	Notes
Shear	70 lbf	1, 4
Tensile	25 lbf	2, 4
Torque	35 lbf-in	3, 4

**NOTES:**

1. A shear load is defined as a load applied to the IHS in a direction parallel to the IHS top surface.
2. A tensile load is defined as a pulling load applied to the IHS in a direction normal to the IHS surface.
3. A torque load is defined as a twisting load applied to the IHS in an axis of rotation normal to the IHS top surface.
4. These guidelines are based on limited testing for design characterization.

### 3.5 Package Insertion Specifications

The Celeron D processor in the 775-land package can be inserted into and removed from a LGA775 socket 15 times. The socket should meet the LGA775 requirements detailed in the *LGA775 Socket Mechanical Design Guide*.

### 3.6 Processor Mass Specification

The typical mass of the Celeron D processor in the 775-land package is 21.5 g [0.76 oz]. This mass [weight] includes all the components that are included in the package.

### 3.7 Processor Materials

Table 3-3 lists some of the package components and associated materials.

**Table 3-3. Processor Materials**

Component	Material
Integrated Heat Spreader (IHS)	Nickel Plated Copper
Substrate	Fiber Reinforced Resin
Substrate Lands	Gold Plated Copper

### 3.8 Processor Markings

Figure 3-6 and Figure 3-6 show the topside markings on the processor. This diagrams are to aid in the identification of the Celeron D processor in the 775-land package.

**Figure 3-5. Processor Top-Side Marking Example (with Processor Number)**

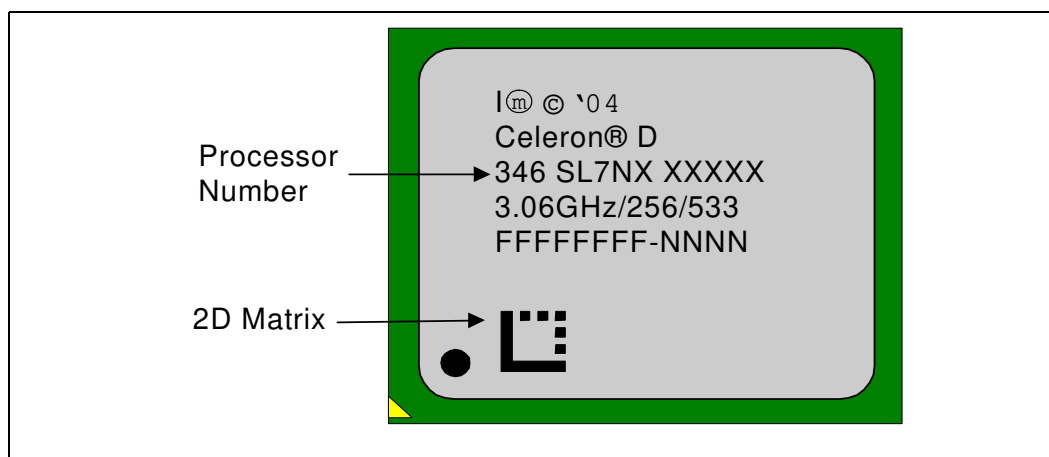
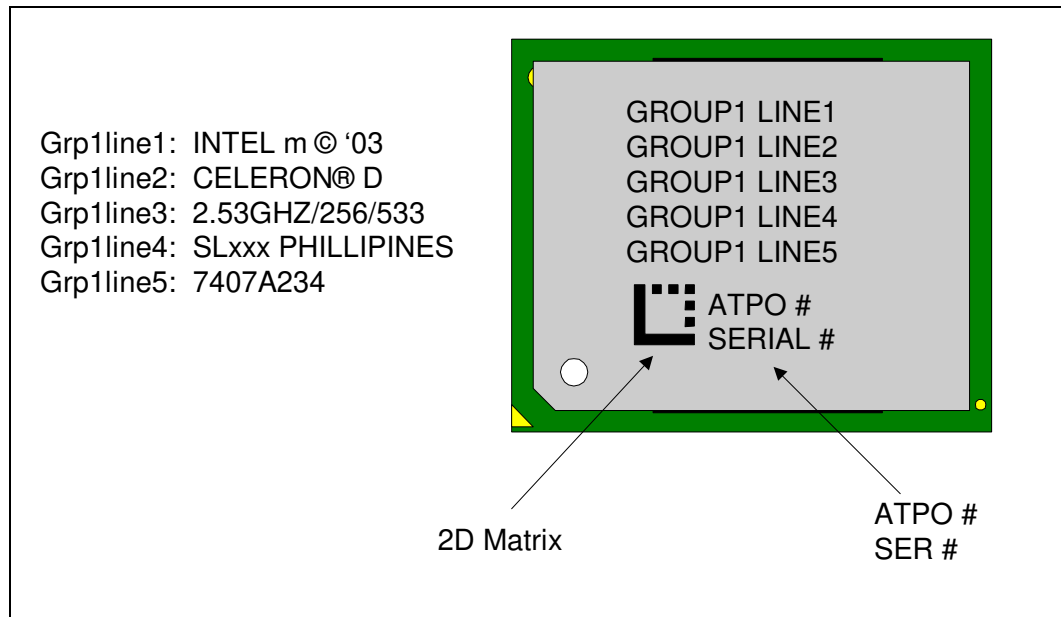

Figure 3-6. Processor Top-Side Marking Example



### 3.9 Processor Land Coordinates

Figure 3-7 shows the top view of the processor land coordinates. The coordinates are referred to throughout the document to identify processor lands.

Figure 3-7. Processor Land Coordinates (Top View)

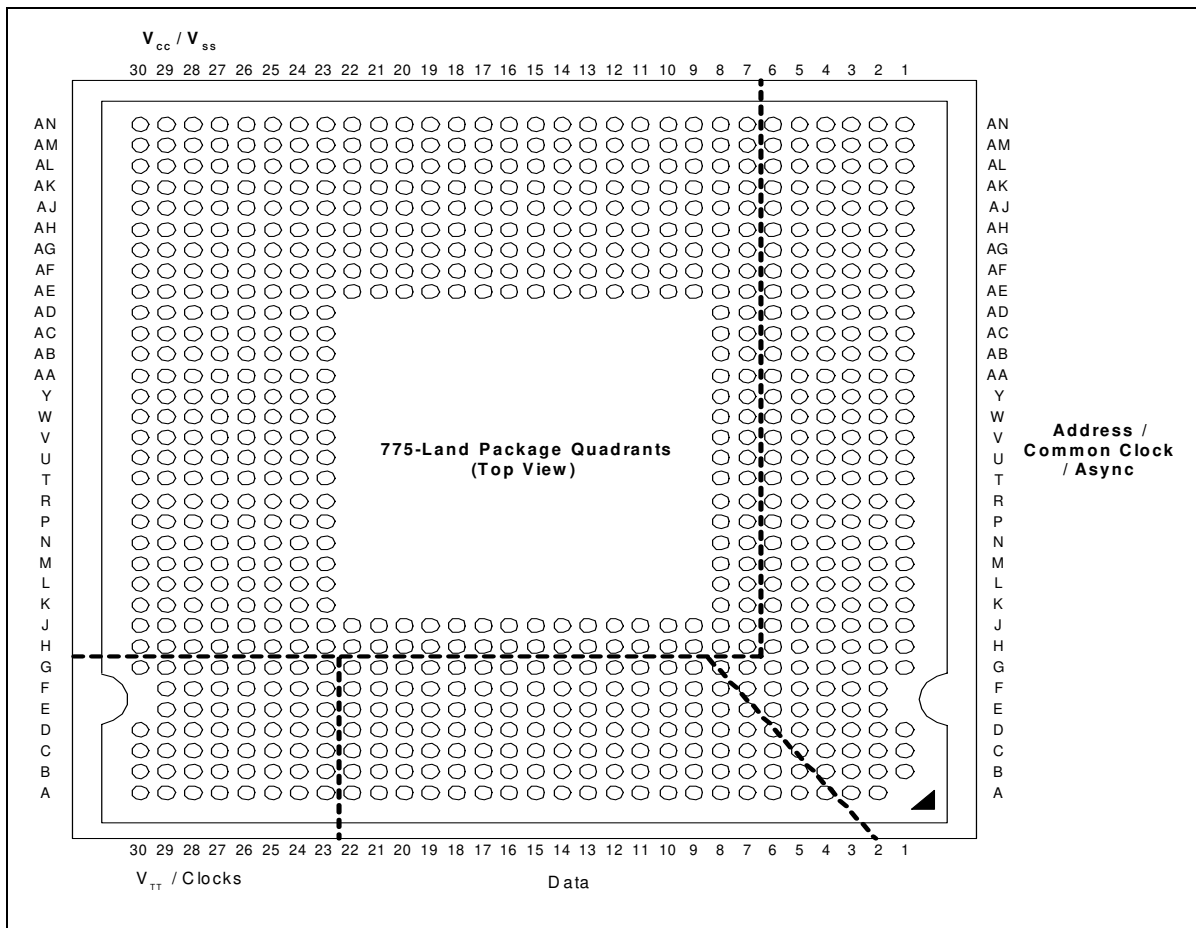

§



# 4 *Land Listing and Signal Descriptions*

---

This chapter contains the processor land assignments and signal descriptions.

## 4.1 **Processor Land Assignments**

This section contains the land listings for the Celeron D processor in the 775-land package. The landout footprint is shown in [Figure 4-1](#) and [Figure 4-2](#). These figures show the physical location of each signal on the package landout footprint (top view). [Table 4-1](#) is a listing of all processor lands ordered alphabetically by land (signal) name. [Table 4-2](#) is also a listing of all processor lands; the ordering is by land number.

Figure 4-1. Landout Diagram (Top View – Left Side)

	30	29	28	27	26	25	24	23	22	21	20	19	18	17	16	15	
AN	VCC	VCC	VSS	VSS	VCC	VCC	VSS	VSS	VCC	VCC	VSS	VCC	VCC	VSS	VSS	VCC	
AM	VCC	VCC	VSS	VSS	VCC	VCC	VSS	VSS	VCC	VCC	VSS	VCC	VCC	VSS	VSS	VCC	
AL	VCC	VCC	VSS	VSS	VCC	VCC	VSS	VSS	VCC	VCC	VSS	VCC	VCC	VSS	VSS	VCC	
AK	VSS	VSS	VSS	VSS	VCC	VCC	VSS	VSS	VCC	VCC	VSS	VCC	VCC	VSS	VSS	VCC	
AJ	VSS	VSS	VSS	VSS	VCC	VCC	VSS	VSS	VCC	VCC	VSS	VCC	VCC	VSS	VSS	VCC	
AH	VCC	VCC	VCC	VCC	VCC	VCC	VSS	VSS	VCC	VCC	VSS	VCC	VCC	VSS	VSS	VCC	
AG	VCC	VCC	VCC	VCC	VCC	VCC	VSS	VSS	VCC	VCC	VSS	VCC	VCC	VSS	VSS	VCC	
AF	VSS	VSS	VSS	VSS	VSS	VSS	VSS	VSS	VCC	VCC	VSS	VCC	VCC	VSS	VSS	VCC	
AE	VSS	VSS	VSS	VSS	VSS	VSS	VSS	VCC	VCC	VCC	VSS	VCC	VCC	VSS	VSS	VCC	
AD	VCC	VCC	VCC	VCC	VCC	VCC	VCC	VCC									
AC	VCC	VCC	VCC	VCC	VCC	VCC	VCC	VCC									
AB	VSS	VSS	VSS	VSS	VSS	VSS	VSS	VSS									
AA	VSS	VSS	VSS	VSS	VSS	VSS	VSS	VSS									
Y	VCC	VCC	VCC	VCC	VCC	VCC	VCC	VCC									
W	VCC	VCC	VCC	VCC	VCC	VCC	VCC	VCC									
V	VSS	VSS	VSS	VSS	VSS	VSS	VSS	VSS									
U	VCC	VCC	VCC	VCC	VCC	VCC	VCC	VCC									
T	VCC	VCC	VCC	VCC	VCC	VCC	VCC	VCC									
R	VSS	VSS	VSS	VSS	VSS	VSS	VSS	VSS									
P	VSS	VSS	VSS	VSS	VSS	VSS	VSS	VSS									
N	VCC	VCC	VCC	VCC	VCC	VCC	VCC	VCC									
M	VCC	VCC	VCC	VCC	VCC	VCC	VCC	VCC									
L	VSS	VSS	VSS	VSS	VSS	VSS	VSS	VSS									
K	VCC	VCC	VCC	VCC	VCC	VCC	VCC	VCC									
J	VCC	VCC	VCC	VCC	VCC	VCC	VCC	VCC	VCC	VCC	VCC	VCC	VCC	DP3#	DP0#	VCC	
H	BSEL1	GTLREF_SEL	VSS	VSS	VSS	VSS	VSS	VSS	VSS	VSS	VSS	VSS	VSS	VSS	VSS	DP2#	DP1#
G	BSEL2	BSEL0	BCLK1	TESTH4	TESTH5	TESTH3	TESTH6	RESET#	D47#	D44#	DSTBN2#	DSTBP2#	D35#	D36#	D32#	D31#	
F		RSVD	BCLK0	VTT_SEL	TESTH0	TESTH2	TESTH7	RSVD	VSS	D43#	D41#	VSS	D38#	D37#	VSS	D30#	
E		VSS	VSS	VSS	VSS	VSS	RSVD	RSVD	D45#	D42#	VSS	D40#	D39#	VSS	D34#	D33#	
D	VTT	VTT	VTT	VTT	VTT	VTT	VSS	RSVD	D46#	VSS	D48#	DBI2#	VSS	D49#	RSVD	VSS	
C	VTT	VTT	VTT	VTT	VTT	VTT	VSS	VCCIO_PLL	VSS	D58#	DBI3#	VSS	D54#	DSTBP3#	VSS	D51#	
B	VTT	VTT	VTT	VTT	VTT	VTT	VSS	VSSA	D63#	D59#	VSS	D60#	D57#	VSS	D55#	D53#	
A	VTT	VTT	VTT	VTT	VTT	VTT	VSS	VCCA	D62#	VSS	RSVD	D61#	VSS	D56#	DSTBN3#	VSS	

Figure 4-2. Landout Diagram (Top View – Right Side)

14	13	12	11	10	9	8	7	6	5	4	3	2	1	
VCC	VSS	VCC	VCC	VSS	VCC	VCC	VID_SELECT	VSS_MB_REGULATION	VCC_MB_REGULATION	VSS_SENSE	VCC_SENSE	VSS	VSS	AN
VCC	VSS	VCC	VCC	VSS	VCC	VCC	VID7	VTPWRGD	VID6	VSS	VID2	VID0	VSS	AM
VCC	VSS	VCC	VCC	VSS	VCC	VCC	VSS	VID3	VID1	VID5	VSS	PROCHOT#	THERMDA	AL
VCC	VSS	VCC	VCC	VSS	VCC	VCC	VSS	RSVD	VSS	VID4	ITP_CLK0	VSS	THERMDC	AK
VCC	VSS	VCC	VCC	VSS	VCC	VCC	VSS	A35#	A34#	VSS	ITP_CLK1	BPM0#	BPM1#	AJ
VCC	VSS	VCC	VCC	VSS	VCC	VCC	VSS	VSS	A33#	A32#	VSS	RSVD	VSS	AH
VCC	VSS	VCC	VCC	VSS	VCC	VCC	VSS	A29#	A31#	A30#	BPM5#	BPM3#	TRST#	AG
VCC	VSS	VCC	VCC	VSS	VCC	VCC	VSS	VSS	A27#	A28#	VSS	BPM4#	TDO	AF
VCC	VSS	VCC	VCC	VSS	VCC	VCC	SKTOCC#	VSS	RSVD	VSS	RSVD	VSS	TCK	AE
						VCC	VSS	A22#	ADSTB1#	VSS	BINIT#	BPM2#	TDI	AD
						VCC	VSS	VSS	A25#	RSVD	VSS	DBR#	TMS	AC
						VCC	VSS	A17#	A24#	A26#	MCERR#	IERR#	VSS	AB
						VCC	VSS	VSS	A23#	A21#	VSS	LL_ID1	VTT_OUT_RIGHT	AA
						VCC	VSS	A19#	VSS	A20#	RSVD	VSS	BOOT_SELECT	Y
						VCC	VSS	A18#	A16#	VSS	TESTHI1	TESTHI12	MS_ID0	W
						VCC	VSS	VSS	A14#	A15#	VSS	LL_ID0	MS_ID1	V
						VCC	VSS	A10#	A12#	A13#	AP1#	AP0#	VSS	U
						VCC	VSS	VSS	A9#	A11#	VSS	COMP5	COMP1	T
						VCC	VSS	ADSTB0#	VSS	A8#	FERR#/PBE#	VSS	COMP3	R
						VCC	VSS	A4#	RSVD	VSS	INIT#	SMI#	TESTHI11	P
						VCC	VSS	VSS	RSVD	RSVD	VSS	IGNNE#	PWRGOOD	N
						VCC	VSS	REQ2#	A5#	A7#	STPCLK#	THERMTRIP#	VSS	M
						VCC	VSS	VSS	A3#	A6#	VSS	TESTHI13	LINT1	L
VCC	VSS	REQ3#	VSS	REQ0#	A20M#	VSS	LINT0	K						
VCC	VCC	VCC	VCC	VCC	VCC	VCC	VSS	REQ4#	REQ1#	VSS	RSVD	COMP4	VTT_OUT_LEFT	J
VSS	VSS	VSS	VSS	VSS	VSS	VSS	VSS	VSS	TESTHI10	RSP#	VSS	GTLREF1	GTLREF0	H
D29#	D27#	DSTBN1#	DBI1#	RSVD	D16#	BPRI#	DEFER#	RSVD	PC_REQ#	TESTHI9	TESTHI8	COMP2	VSS	G
D28#	VSS	D24#	D23#	VSS	D18#	D17#	VSS	RSVD	RS1#	VSS	BR0#	EDRDY#		F
VSS	D26#	DSTBP1#	VSS	D21#	D19#	VSS	RSVD	RSVD	RSVD	HITM#	TRDY#	VSS		E
RSVD	D25#	VSS	D15#	D22#	VSS	D12#	D20#	VSS	VSS	HIT#	VSS	ADS#	RSVD	D
D52#	VSS	D14#	D11#	VSS	RSVD	DSTBN0#	VSS	D3#	D1#	VSS	LOCK#	BNR#	DRDY#	C
VSS	RSVD	D13#	VSS	D10#	DSTBP0#	VSS	D6#	D5#	VSS	D0#	RS0#	DBSY#	VSS	B
D50#	COMP0	VSS	D9#	D8#	VSS	DBI0#	D7#	VSS	D4#	D2#	RS2#	VSS		A

**Table 4-1. Alphabetical Land Assignments**

Land Name	Land #	Signal Buffer Type	Direction
A3#	L5	Source Synch	Input/Output
A4#	P6	Source Synch	Input/Output
A5#	M5	Source Synch	Input/Output
A6#	L4	Source Synch	Input/Output
A7#	M4	Source Synch	Input/Output
A8#	R4	Source Synch	Input/Output
A9#	T5	Source Synch	Input/Output
A10#	U6	Source Synch	Input/Output
A11#	T4	Source Synch	Input/Output
A12#	U5	Source Synch	Input/Output
A13#	U4	Source Synch	Input/Output
A14#	V5	Source Synch	Input/Output
A15#	V4	Source Synch	Input/Output
A16#	W5	Source Synch	Input/Output
A17#	AB6	Source Synch	Input/Output
A18#	W6	Source Synch	Input/Output
A19#	Y6	Source Synch	Input/Output
A20#	Y4	Source Synch	Input/Output
A20M#	K3	Asynch GTL+	Input
A21#	AA4	Source Synch	Input/Output
A22#	AD6	Source Synch	Input/Output
A23#	AA5	Source Synch	Input/Output
A24#	AB5	Source Synch	Input/Output
A25#	AC5	Source Synch	Input/Output
A26#	AB4	Source Synch	Input/Output
A27#	AF5	Source Synch	Input/Output
A28#	AF4	Source Synch	Input/Output
A29#	AG6	Source Synch	Input/Output
A30#	AG4	Source Synch	Input/Output
A31#	AG5	Source Synch	Input/Output
A32#	AH4	Source Synch	Input/Output
A33#	AH5	Source Synch	Input/Output
A34#	AJ5	Source Synch	Input/Output
A35#	AJ6	Source Synch	Input/Output
ADS#	D2	Common Clock	Input/Output
ADSTB0#	R6	Source Synch	Input/Output
ADSTB1#	AD5	Source Synch	Input/Output
AP0#	U2	Common Clock	Input/Output
AP1#	U3	Common Clock	Input/Output
BCLK0	F28	Clock	Input
BCLK1	G28	Clock	Input
BINIT#	AD3	Common Clock	Input/Output
BNR#	C2	Common Clock	Input/Output
BOOTSELECT	Y1	Power/Other	Input

**Table 4-1. Alphabetical Land Assignments**

Land Name	Land #	Signal Buffer Type	Direction
BPM0#	AJ2	Common Clock	Input/Output
BPM1#	AJ1	Common Clock	Input/Output
BPM2#	AD2	Common Clock	Input/Output
BPM3#	AG2	Common Clock	Input/Output
BPM4#	AF2	Common Clock	Input/Output
BPM5#	AG3	Common Clock	Input/Output
BPRI#	G8	Common Clock	Input
BR0#	F3	Common Clock	Input/Output
BSEL0	G29	Power/Other	Output
BSEL1	H30	Power/Other	Output
BSEL2	G30	Power/Other	Output
COMP0	A13	Power/Other	Input
COMP1	T1	Power/Other	Input
COMP2	G2	Power/Other	Input
COMP3	R1	Power/Other	Input
COMP4	J2	Power/Other	Input
COMP5	T2	Power/Other	Input
D0#	B4	Source Synch	Input/Output
D1#	C5	Source Synch	Input/Output
D2#	A4	Source Synch	Input/Output
D3#	C6	Source Synch	Input/Output
D4#	A5	Source Synch	Input/Output
D5#	B6	Source Synch	Input/Output
D6#	B7	Source Synch	Input/Output
D7#	A7	Source Synch	Input/Output
D8#	A10	Source Synch	Input/Output
D9#	A11	Source Synch	Input/Output
D10#	B10	Source Synch	Input/Output
D11#	C11	Source Synch	Input/Output
D12#	D8	Source Synch	Input/Output
D13#	B12	Source Synch	Input/Output
D14#	C12	Source Synch	Input/Output
D15#	D11	Source Synch	Input/Output
D16#	G9	Source Synch	Input/Output
D17#	F8	Source Synch	Input/Output
D18#	F9	Source Synch	Input/Output
D19#	E9	Source Synch	Input/Output
D20#	D7	Source Synch	Input/Output
D21#	E10	Source Synch	Input/Output
D22#	D10	Source Synch	Input/Output
D23#	F11	Source Synch	Input/Output
D24#	F12	Source Synch	Input/Output
D25#	D13	Source Synch	Input/Output
D26#	E13	Source Synch	Input/Output

**Table 4-1. Alphabetical Land Assignments**

Land Name	Land #	Signal Buffer Type	Direction
D27#	G13	Source Synch	Input/Output
D28#	F14	Source Synch	Input/Output
D29#	G14	Source Synch	Input/Output
D30#	F15	Source Synch	Input/Output
D31#	G15	Source Synch	Input/Output
D32#	G16	Source Synch	Input/Output
D33#	E15	Source Synch	Input/Output
D34#	E16	Source Synch	Input/Output
D35#	G18	Source Synch	Input/Output
D36#	G17	Source Synch	Input/Output
D37#	F17	Source Synch	Input/Output
D38#	F18	Source Synch	Input/Output
D39#	E18	Source Synch	Input/Output
D40#	E19	Source Synch	Input/Output
D41#	F20	Source Synch	Input/Output
D42#	E21	Source Synch	Input/Output
D43#	F21	Source Synch	Input/Output
D44#	G21	Source Synch	Input/Output
D45#	E22	Source Synch	Input/Output
D46#	D22	Source Synch	Input/Output
D47#	G22	Source Synch	Input/Output
D48#	D20	Source Synch	Input/Output
D49#	D17	Source Synch	Input/Output
D50#	A14	Source Synch	Input/Output
D51#	C15	Source Synch	Input/Output
D52#	C14	Source Synch	Input/Output
D53#	B15	Source Synch	Input/Output
D54#	C18	Source Synch	Input/Output
D55#	B16	Source Synch	Input/Output
D56#	A17	Source Synch	Input/Output
D57#	B18	Source Synch	Input/Output
D58#	C21	Source Synch	Input/Output
D59#	B21	Source Synch	Input/Output
D60#	B19	Source Synch	Input/Output
D61#	A19	Source Synch	Input/Output
D62#	A22	Source Synch	Input/Output
D63#	B22	Source Synch	Input/Output
DBI0#	A8	Source Synch	Input/Output
DBI1#	G11	Source Synch	Input/Output
DBI2#	D19	Source Synch	Input/Output
DBI3#	C20	Source Synch	Input/Output
DBR#	AC2	Power/Other	Output
DBSY#	B2	Common Clock	Input/Output
DEFER#	G7	Common Clock	Input

**Table 4-1. Alphabetical Land Assignments**

Land Name	Land #	Signal Buffer Type	Direction
DP0#	J16	Common Clock	Input/Output
DP1#	H15	Common Clock	Input/Output
DP2#	H16	Common Clock	Input/Output
DP3#	J17	Common Clock	Input/Output
DRDY#	C1	Common Clock	Input/Output
DSTBN0#	C8	Source Synch	Input/Output
DSTBN1#	G12	Source Synch	Input/Output
DSTBN2#	G20	Source Synch	Input/Output
DSTBN3#	A16	Source Synch	Input/Output
DSTBP0#	B9	Source Synch	Input/Output
DSTBP1#	E12	Source Synch	Input/Output
DSTBP2#	G19	Source Synch	Input/Output
DSTBP3#	C17	Source Synch	Input/Output
EDRDY# <sup>1</sup>	F2	Common Clock	Input
FERR#/PBE#	R3	Asynch GTL+	Output
GTLREF_SEL	H29	Power/Other	—
GTLREF0	H1	Power/Other	Input
GTLREF1	H2	—	—
HIT#	D4	Common Clock	Input/Output
HITM#	E4	Common Clock	Input/Output
IERR#	AB2	Asynch GTL+	Output
IGNNE#	N2	Asynch GTL+	Input
INIT#	P3	Asynch GTL+	Input
ITP_CLK0	AK3	TAP	Input
ITP_CLK1	AJ3	TAP	Input
LINT0	K1	Asynch GTL+	Input
LINT1	L1	Asynch GTL+	Input
LL_ID0	V2	Power/Other	Output
LL_ID1	AA2	Power/Other	Output
LOCK#	C3	Common Clock	Input/Output
MCERR#	AB3	Common Clock	Input/Output
MS_ID0	W1	Power/Other	Output
MS_ID1	V1	Power/Other	Output
PC_REQ# <sup>1</sup>	G5	Common Clock	Output
PROCHOT#	AL2	Asynch GTL+	Input/Output
PWRGOOD	N1	Power/Other	Input
REQ0#	K4	Source Synch	Input/Output
REQ1#	J5	Source Synch	Input/Output
REQ2#	M6	Source Synch	Input/Output
REQ3#	K6	Source Synch	Input/Output
REQ4#	J6	Source Synch	Input/Output
RESERVED	A20	—	—
RESERVED	AC4	—	—
RESERVED	AE3	—	—

**Table 4-1. Alphabetical Land Assignments**

Land Name	Land #	Signal Buffer Type	Direction
RESERVED	AE4	—	—
RESERVED	AE6	—	—
RESERVED	AH2	—	—
RESERVED	C9	—	—
RESERVED	D1	—	—
RESERVED	D14	—	—
RESERVED	D16	—	—
RESERVED	E23	—	—
RESERVED	E24	—	—
RESERVED	E5	—	—
RESERVED	E6	—	—
RESERVED	E7	—	—
RESERVED	F23	—	—
RESERVED	F29	—	—
RESERVED	F6	—	—
RESERVED	G10	—	—
RESERVED	B13	—	—
RESERVED	J3	—	—
RESERVED	N4	—	—
RESERVED	N5	—	—
RESERVED	P5	—	—
RESERVED	Y3	—	—
RESERVED	D23	—	—
RESERVED	AK6	—	—
RESERVED	G6	—	—
RESET#	G23	Common Clock	Input
RS0#	B3	Common Clock	Input
RS1#	F5	Common Clock	Input
RS2#	A3	Common Clock	Input
RSP#	H4	Common Clock	Input
SKTOCC#	AE8	Power/Other	Output
SMI#	P2	Asynch GTL+	Input
STPCLK#	M3	Asynch GTL+	Input
TCK	AE1	TAP	Input
TDI	AD1	TAP	Input
TDO	AF1	TAP	Output
TESTHI0	F26	Power/Other	Input
TESTHI1	W3	Power/Other	Input
TESTHI2	F25	Power/Other	Input
TESTHI3	G25	Power/Other	Input
TESTHI4	G27	Power/Other	Input
TESTHI5	G26	Power/Other	Input
TESTHI6	G24	Power/Other	Input
TESTHI7	F24	Power/Other	Input

**Table 4-1. Alphabetical Land Assignments**

Land Name	Land #	Signal Buffer Type	Direction
TESTHI8	G3	Power/Other	Input
TESTHI9	G4	Power/Other	Input
TESTHI10	H5	Power/Other	Input
TESTHI11	P1	Power/Other	Input
TESTHI12	W2	Power/Other	Input
TESTHI13	L2	Power/Other	Input
THERMDA	AL1	Power/Other	—
THERMDC	AK1	Power/Other	—
THERMTRIP#	M2	Asynch GTL+	Output
TMS	AC1	TAP	Input
TRDY#	E3	Common Clock	Input
TRST#	AG1	TAP	Input
VCC	AA8	Power/Other	—
VCC	AB8	Power/Other	—
VCC	AC23	Power/Other	—
VCC	AC24	Power/Other	—
VCC	AC25	Power/Other	—
VCC	AC26	Power/Other	—
VCC	AC27	Power/Other	—
VCC	AC28	Power/Other	—
VCC	AC29	Power/Other	—
VCC	AC30	Power/Other	—
VCC	AC8	Power/Other	—
VCC	AD23	Power/Other	—
VCC	AD24	Power/Other	—
VCC	AD25	Power/Other	—
VCC	AD26	Power/Other	—
VCC	AD27	Power/Other	—
VCC	AD28	Power/Other	—
VCC	AD29	Power/Other	—
VCC	AD30	Power/Other	—
VCC	AD8	Power/Other	—
VCC	AE11	Power/Other	—
VCC	AE12	Power/Other	—
VCC	AE14	Power/Other	—
VCC	AE15	Power/Other	—
VCC	AE18	Power/Other	—
VCC	AE19	Power/Other	—
VCC	AE21	Power/Other	—
VCC	AE22	Power/Other	—
VCC	AE23	Power/Other	—
VCC	AE9	Power/Other	—
VCC	AF11	Power/Other	—
VCC	AF12	Power/Other	—

**Table 4-1. Alphabetical Land Assignments**

Land Name	Land #	Signal Buffer Type	Direction
VCC	AF14	Power/Other	—
VCC	AF15	Power/Other	—
VCC	AF18	Power/Other	—
VCC	AF19	Power/Other	—
VCC	AF21	Power/Other	—
VCC	AF22	Power/Other	—
VCC	AF8	Power/Other	—
VCC	AF9	Power/Other	—
VCC	AG11	Power/Other	—
VCC	AG12	Power/Other	—
VCC	AG14	Power/Other	—
VCC	AG15	Power/Other	—
VCC	AG18	Power/Other	—
VCC	AG19	Power/Other	—
VCC	AG21	Power/Other	—
VCC	AG22	Power/Other	—
VCC	AG25	Power/Other	—
VCC	AG26	Power/Other	—
VCC	AG27	Power/Other	—
VCC	AG28	Power/Other	—
VCC	AG29	Power/Other	—
VCC	AG30	Power/Other	—
VCC	AG8	Power/Other	—
VCC	AG9	Power/Other	—
VCC	AH11	Power/Other	—
VCC	AH12	Power/Other	—
VCC	AH14	Power/Other	—
VCC	AH15	Power/Other	—
VCC	AH18	Power/Other	—
VCC	AH19	Power/Other	—
VCC	AH21	Power/Other	—
VCC	AH22	Power/Other	—
VCC	AH25	Power/Other	—
VCC	AH26	Power/Other	—
VCC	AH27	Power/Other	—
VCC	AH28	Power/Other	—
VCC	AH29	Power/Other	—
VCC	AH30	Power/Other	—
VCC	AH8	Power/Other	—
VCC	AH9	Power/Other	—
VCC	AJ11	Power/Other	—
VCC	AJ12	Power/Other	—
VCC	AJ14	Power/Other	—
VCC	AJ15	Power/Other	—

**Table 4-1. Alphabetical Land Assignments**

Land Name	Land #	Signal Buffer Type	Direction
VCC	AJ18	Power/Other	—
VCC	AJ19	Power/Other	—
VCC	AJ21	Power/Other	—
VCC	AJ22	Power/Other	—
VCC	AJ25	Power/Other	—
VCC	AJ26	Power/Other	—
VCC	AJ8	Power/Other	—
VCC	AJ9	Power/Other	—
VCC	AK11	Power/Other	—
VCC	AK12	Power/Other	—
VCC	AK14	Power/Other	—
VCC	AK15	Power/Other	—
VCC	AK18	Power/Other	—
VCC	AK19	Power/Other	—
VCC	AK21	Power/Other	—
VCC	AK22	Power/Other	—
VCC	AK25	Power/Other	—
VCC	AK26	Power/Other	—
VCC	AK8	Power/Other	—
VCC	AK9	Power/Other	—
VCC	AL11	Power/Other	—
VCC	AL12	Power/Other	—
VCC	AL14	Power/Other	—
VCC	AL15	Power/Other	—
VCC	AL18	Power/Other	—
VCC	AL19	Power/Other	—
VCC	AL21	Power/Other	—
VCC	AL22	Power/Other	—
VCC	AL25	Power/Other	—
VCC	AL26	Power/Other	—
VCC	AL29	Power/Other	—
VCC	AL30	Power/Other	—
VCC	AL8	Power/Other	—
VCC	AL9	Power/Other	—
VCC	AM11	Power/Other	—
VCC	AM12	Power/Other	—
VCC	AM14	Power/Other	—
VCC	AM15	Power/Other	—
VCC	AM18	Power/Other	—
VCC	AM19	Power/Other	—
VCC	AM21	Power/Other	—
VCC	AM22	Power/Other	—
VCC	AM25	Power/Other	—
VCC	AM26	Power/Other	—

**Table 4-1. Alphabetical Land Assignments**

Land Name	Land #	Signal Buffer Type	Direction
VCC	AM29	Power/Other	—
VCC	AM30	Power/Other	—
VCC	AM8	Power/Other	—
VCC	AM9	Power/Other	—
VCC	AN11	Power/Other	—
VCC	AN12	Power/Other	—
VCC	AN14	Power/Other	—
VCC	AN15	Power/Other	—
VCC	AN18	Power/Other	—
VCC	AN19	Power/Other	—
VCC	AN21	Power/Other	—
VCC	AN22	Power/Other	—
VCC	AN25	Power/Other	—
VCC	AN26	Power/Other	—
VCC	AN29	Power/Other	—
VCC	AN30	Power/Other	—
VCC	AN8	Power/Other	—
VCC	AN9	Power/Other	—
VCC	J10	Power/Other	—
VCC	J11	Power/Other	—
VCC	J12	Power/Other	—
VCC	J13	Power/Other	—
VCC	J14	Power/Other	—
VCC	J15	Power/Other	—
VCC	J18	Power/Other	—
VCC	J19	Power/Other	—
VCC	J20	Power/Other	—
VCC	J21	Power/Other	—
VCC	J22	Power/Other	—
VCC	J23	Power/Other	—
VCC	J24	Power/Other	—
VCC	J25	Power/Other	—
VCC	J26	Power/Other	—
VCC	J27	Power/Other	—
VCC	J28	Power/Other	—
VCC	J29	Power/Other	—
VCC	J30	Power/Other	—
VCC	J8	Power/Other	—
VCC	J9	Power/Other	—
VCC	K23	Power/Other	—
VCC	K24	Power/Other	—
VCC	K25	Power/Other	—
VCC	K26	Power/Other	—
VCC	K27	Power/Other	—

**Table 4-1. Alphabetical Land Assignments**

Land Name	Land #	Signal Buffer Type	Direction
VCC	K28	Power/Other	—
VCC	K29	Power/Other	—
VCC	K30	Power/Other	—
VCC	K8	Power/Other	—
VCC	L8	Power/Other	—
VCC	M23	Power/Other	—
VCC	M24	Power/Other	—
VCC	M25	Power/Other	—
VCC	M26	Power/Other	—
VCC	M27	Power/Other	—
VCC	M28	Power/Other	—
VCC	M29	Power/Other	—
VCC	M30	Power/Other	—
VCC	M8	Power/Other	—
VCC	N23	Power/Other	—
VCC	N24	Power/Other	—
VCC	N25	Power/Other	—
VCC	N26	Power/Other	—
VCC	N27	Power/Other	—
VCC	N28	Power/Other	—
VCC	N29	Power/Other	—
VCC	N30	Power/Other	—
VCC	N8	Power/Other	—
VCC	P8	Power/Other	—
VCC	R8	Power/Other	—
VCC	T23	Power/Other	—
VCC	T24	Power/Other	—
VCC	T25	Power/Other	—
VCC	T26	Power/Other	—
VCC	T27	Power/Other	—
VCC	T28	Power/Other	—
VCC	T29	Power/Other	—
VCC	T30	Power/Other	—
VCC	T8	Power/Other	—
VCC	U23	Power/Other	—
VCC	U24	Power/Other	—
VCC	U25	Power/Other	—
VCC	U26	Power/Other	—
VCC	U27	Power/Other	—
VCC	U28	Power/Other	—
VCC	U29	Power/Other	—
VCC	U30	Power/Other	—
VCC	U8	Power/Other	—
VCC	V8	Power/Other	—



**Table 4-1. Alphabetical Land Assignments**

Land Name	Land #	Signal Buffer Type	Direction
VCC	W23	Power/Other	—
VCC	W24	Power/Other	—
VCC	W25	Power/Other	—
VCC	W26	Power/Other	—
VCC	W27	Power/Other	—
VCC	W28	Power/Other	—
VCC	W29	Power/Other	—
VCC	W30	Power/Other	—
VCC	W8	Power/Other	—
VCC	Y23	Power/Other	—
VCC	Y24	Power/Other	—
VCC	Y25	Power/Other	—
VCC	Y26	Power/Other	—
VCC	Y27	Power/Other	—
VCC	Y28	Power/Other	—
VCC	Y29	Power/Other	—
VCC	Y30	Power/Other	—
VCC	Y8	Power/Other	—
VCC_MB REGULATION	AN5	Power/Other	Output
VCCA	A23	Power/Other	—
VCCIOPLL	C23	Power/Other	—
VCC_SENSE	AN3	Power/Other	Output
VID_SELECT	AN7	Power/Other	Output
VID0	AM2	Power/Other	Output
VID1	AL5	Power/Other	Output
VID2	AM3	Power/Other	Output
VID3	AL6	Power/Other	Output
VID4	AK4	Power/Other	Output
VID5	AL4	Power/Other	Output
VID6	AM5	Power/Other	Output
VID7	AM7	Power/Other	Output
VSS	A12	Power/Other	—
VSS	A15	Power/Other	—
VSS	A18	Power/Other	—
VSS	A2	Power/Other	—
VSS	A21	Power/Other	—
VSS	A24	Power/Other	—
VSS	A6	Power/Other	—
VSS	A9	Power/Other	—
VSS	AA23	Power/Other	—
VSS	AA24	Power/Other	—
VSS	AA25	Power/Other	—
VSS	AA26	Power/Other	—

**Table 4-1. Alphabetical Land Assignments**

Land Name	Land #	Signal Buffer Type	Direction
VSS	AA27	Power/Other	—
VSS	AA28	Power/Other	—
VSS	AA29	Power/Other	—
VSS	AA3	Power/Other	—
VSS	AA30	Power/Other	—
VSS	AA6	Power/Other	—
VSS	AA7	Power/Other	—
VSS	AB1	Power/Other	—
VSS	AB23	Power/Other	—
VSS	AB24	Power/Other	—
VSS	AB25	Power/Other	—
VSS	AB26	Power/Other	—
VSS	AB27	Power/Other	—
VSS	AB28	Power/Other	—
VSS	AB29	Power/Other	—
VSS	AB30	Power/Other	—
VSS	AB7	Power/Other	—
VSS	AC3	Power/Other	—
VSS	AC6	Power/Other	—
VSS	AC7	Power/Other	—
VSS	AD4	Power/Other	—
VSS	AD7	Power/Other	—
VSS	AE10	Power/Other	—
VSS	AE13	Power/Other	—
VSS	AE16	Power/Other	—
VSS	AE17	Power/Other	—
VSS	AE2	Power/Other	—
VSS	AE20	Power/Other	—
VSS	AE24	Power/Other	—
VSS	AE25	Power/Other	—
VSS	AE26	Power/Other	—
VSS	AE27	Power/Other	—
VSS	AE28	Power/Other	—
VSS	AE29	Power/Other	—
VSS	AE30	Power/Other	—
VSS	AE5	Power/Other	—
VSS	AE7	Power/Other	—
VSS	AF10	Power/Other	—
VSS	AF13	Power/Other	—
VSS	AF16	Power/Other	—
VSS	AF17	Power/Other	—
VSS	AF20	Power/Other	—
VSS	AF23	Power/Other	—
VSS	AF24	Power/Other	—

**Table 4-1. Alphabetical Land Assignments**

Land Name	Land #	Signal Buffer Type	Direction
VSS	AF25	Power/Other	—
VSS	AF26	Power/Other	—
VSS	AF27	Power/Other	—
VSS	AF28	Power/Other	—
VSS	AF29	Power/Other	—
VSS	AF3	Power/Other	—
VSS	AF30	Power/Other	—
VSS	AF6	Power/Other	—
VSS	AF7	Power/Other	—
VSS	AG10	Power/Other	—
VSS	AG13	Power/Other	—
VSS	AG16	Power/Other	—
VSS	AG17	Power/Other	—
VSS	AG20	Power/Other	—
VSS	AG23	Power/Other	—
VSS	AG24	Power/Other	—
VSS	AG7	Power/Other	—
VSS	AH1	Power/Other	—
VSS	AH10	Power/Other	—
VSS	AH13	Power/Other	—
VSS	AH16	Power/Other	—
VSS	AH17	Power/Other	—
VSS	AH20	Power/Other	—
VSS	AH23	Power/Other	—
VSS	AH24	Power/Other	—
VSS	AH3	Power/Other	—
VSS	AH6	Power/Other	—
VSS	AH7	Power/Other	—
VSS	AJ10	Power/Other	—
VSS	AJ13	Power/Other	—
VSS	AJ16	Power/Other	—
VSS	AJ17	Power/Other	—
VSS	AJ20	Power/Other	—
VSS	AJ23	Power/Other	—
VSS	AJ24	Power/Other	—
VSS	AJ27	Power/Other	—
VSS	AJ28	Power/Other	—
VSS	AJ29	Power/Other	—
VSS	AJ30	Power/Other	—
VSS	AJ4	Power/Other	—
VSS	AJ7	Power/Other	—
VSS	AK10	Power/Other	—
VSS	AK13	Power/Other	—
VSS	AK16	Power/Other	—

**Table 4-1. Alphabetical Land Assignments**

Land Name	Land #	Signal Buffer Type	Direction
VSS	AK17	Power/Other	—
VSS	AK2	Power/Other	—
VSS	AK20	Power/Other	—
VSS	AK23	Power/Other	—
VSS	AK24	Power/Other	—
VSS	AK27	Power/Other	—
VSS	AK28	Power/Other	—
VSS	AK29	Power/Other	—
VSS	AK30	Power/Other	—
VSS	AK5	Power/Other	—
VSS	AK7	Power/Other	—
VSS	AL10	Power/Other	—
VSS	AL13	Power/Other	—
VSS	AL16	Power/Other	—
VSS	AL17	Power/Other	—
VSS	AL20	Power/Other	—
VSS	AL23	Power/Other	—
VSS	AL24	Power/Other	—
VSS	AL27	Power/Other	—
VSS	AL28	Power/Other	—
VSS	AL3	Power/Other	—
VSS	AL7	Power/Other	—
VSS	AM1	Power/Other	—
VSS	AM10	Power/Other	—
VSS	AM13	Power/Other	—
VSS	AM16	Power/Other	—
VSS	AM17	Power/Other	—
VSS	AM20	Power/Other	—
VSS	AM23	Power/Other	—
VSS	AM24	Power/Other	—
VSS	AM27	Power/Other	—
VSS	AM28	Power/Other	—
VSS	AM4	Power/Other	—
VSS	AN1	Power/Other	—
VSS	AN10	Power/Other	—
VSS	AN13	Power/Other	—
VSS	AN16	Power/Other	—
VSS	AN17	Power/Other	—
VSS	AN2	Power/Other	—
VSS	AN20	Power/Other	—
VSS	AN23	Power/Other	—
VSS	AN24	Power/Other	—
VSS	AN27	Power/Other	—
VSS	AN28	Power/Other	—

**Table 4-1. Alphabetical Land Assignments**

Land Name	Land #	Signal Buffer Type	Direction
VSS	B1	Power/Other	—
VSS	B11	Power/Other	—
VSS	B14	Power/Other	—
VSS	B17	Power/Other	—
VSS	B20	Power/Other	—
VSS	B24	Power/Other	—
VSS	B5	Power/Other	—
VSS	B8	Power/Other	—
VSS	C10	Power/Other	—
VSS	C13	Power/Other	—
VSS	C16	Power/Other	—
VSS	C19	Power/Other	—
VSS	C22	Power/Other	—
VSS	C24	Power/Other	—
VSS	C4	Power/Other	—
VSS	C7	Power/Other	—
VSS	D12	Power/Other	—
VSS	D15	Power/Other	—
VSS	D18	Power/Other	—
VSS	D21	Power/Other	—
VSS	D24	Power/Other	—
VSS	D3	Power/Other	—
VSS	D5	Power/Other	—
VSS	D6	Power/Other	—
VSS	D9	Power/Other	—
VSS	E11	Power/Other	—
VSS	E14	Power/Other	—
VSS	E17	Power/Other	—
VSS	E2	Power/Other	—
VSS	E20	Power/Other	—
VSS	E25	Power/Other	—
VSS	E26	Power/Other	—
VSS	E27	Power/Other	—
VSS	E28	Power/Other	—
VSS	E29	Power/Other	—
VSS	E8	Power/Other	—
VSS	F10	Power/Other	—
VSS	F13	Power/Other	—
VSS	F16	Power/Other	—
VSS	F19	Power/Other	—
VSS	F22	Power/Other	—
VSS	F4	Power/Other	—
VSS	F7	Power/Other	—
VSS	G1	Power/Other	—

**Table 4-1. Alphabetical Land Assignments**

Land Name	Land #	Signal Buffer Type	Direction
VSS	H10	Power/Other	—
VSS	H11	Power/Other	—
VSS	H12	Power/Other	—
VSS	H13	Power/Other	—
VSS	H14	Power/Other	—
VSS	H17	Power/Other	—
VSS	H18	Power/Other	—
VSS	H19	Power/Other	—
VSS	H20	Power/Other	—
VSS	H21	Power/Other	—
VSS	H22	Power/Other	—
VSS	H23	Power/Other	—
VSS	H24	Power/Other	—
VSS	H25	Power/Other	—
VSS	H26	Power/Other	—
VSS	H27	Power/Other	—
VSS	H28	Power/Other	—
VSS	H3	Power/Other	—
VSS	H6	Power/Other	—
VSS	H7	Power/Other	—
VSS	H8	Power/Other	—
VSS	H9	Power/Other	—
VSS	J4	Power/Other	—
VSS	J7	Power/Other	—
VSS	K2	Power/Other	—
VSS	K5	Power/Other	—
VSS	K7	Power/Other	—
VSS	L23	Power/Other	—
VSS	L24	Power/Other	—
VSS	L25	Power/Other	—
VSS	L26	Power/Other	—
VSS	L27	Power/Other	—
VSS	L28	Power/Other	—
VSS	L29	Power/Other	—
VSS	L3	Power/Other	—
VSS	L30	Power/Other	—
VSS	L6	Power/Other	—
VSS	L7	Power/Other	—
VSS	M1	Power/Other	—
VSS	M7	Power/Other	—
VSS	N3	Power/Other	—
VSS	N6	Power/Other	—
VSS	N7	Power/Other	—
VSS	P23	Power/Other	—

**Table 4-1. Alphabetical Land Assignments**

Land Name	Land #	Signal Buffer Type	Direction
VSS	P24	Power/Other	—
VSS	P25	Power/Other	—
VSS	P26	Power/Other	—
VSS	P27	Power/Other	—
VSS	P28	Power/Other	—
VSS	P29	Power/Other	—
VSS	P30	Power/Other	—
VSS	P4	Power/Other	—
VSS	P7	Power/Other	—
VSS	R2	Power/Other	—
VSS	R23	Power/Other	—
VSS	R24	Power/Other	—
VSS	R25	Power/Other	—
VSS	R26	Power/Other	—
VSS	R27	Power/Other	—
VSS	R28	Power/Other	—
VSS	R29	Power/Other	—
VSS	R30	Power/Other	—
VSS	R5	Power/Other	—
VSS	R7	Power/Other	—
VSS	T3	Power/Other	—
VSS	T6	Power/Other	—
VSS	T7	Power/Other	—
VSS	U1	Power/Other	—
VSS	U7	Power/Other	—
VSS	V23	Power/Other	—
VSS	V24	Power/Other	—
VSS	V25	Power/Other	—
VSS	V26	Power/Other	—
VSS	V27	Power/Other	—
VSS	V28	Power/Other	—
VSS	V29	Power/Other	—
VSS	V3	Power/Other	—
VSS	V30	Power/Other	—
VSS	V6	Power/Other	—
VSS	V7	Power/Other	—
VSS	W4	Power/Other	—
VSS	W7	Power/Other	—
VSS	Y2	Power/Other	—
VSS	Y5	Power/Other	—
VSS	Y7	Power/Other	—
VSS_MB REGULATION	AN6	Power/Other	Output
VSSA	B23	Power/Other	—

**Table 4-1. Alphabetical Land Assignments**

Land Name	Land #	Signal Buffer Type	Direction
VSS_SENSE	AN4	Power/Other	Output
VTT	A25	Power/Other	—
VTT	A26	Power/Other	—
VTT	A27	Power/Other	—
VTT	A28	Power/Other	—
VTT	A29	Power/Other	—
VTT	A30	Power/Other	—
VTT	B25	Power/Other	—
VTT	B26	Power/Other	—
VTT	B27	Power/Other	—
VTT	B28	Power/Other	—
VTT	B29	Power/Other	—
VTT	B30	Power/Other	—
VTT	C25	Power/Other	—
VTT	C26	Power/Other	—
VTT	C27	Power/Other	—
VTT	C28	Power/Other	—
VTT	C29	Power/Other	—
VTT	C30	Power/Other	—
VTT	D25	Power/Other	—
VTT	D26	Power/Other	—
VTT	D27	Power/Other	—
VTT	D28	Power/Other	—
VTT	D29	Power/Other	—
VTT	D30	Power/Other	—
VTT_OUT_LEFT	J1	Power/Other	Output
VTT_OUT_RIGHT	AA1	Power/Other	Output
VTT_SEL	F27	Power/Other	Output
VTTTPWRGD	AM6	Power/Other	Input

**NOTES:**

- EDRDY# and PC\_REQ# are not features of the Celeron D processor in the 775-land package. They are included here for future processor compatibility.

Table 4-2. Numerical Land Assignments

Land #	Land Name	Signal Buffer Type	Direction
A2	VSS	Power/Other	—
A3	RS2#	Common Clock	Input
A4	D2#	Source Synch	Input/Output
A5	D4#	Source Synch	Input/Output
A6	VSS	Power/Other	—
A7	D7#	Source Synch	Input/Output
A8	DBI0#	Source Synch	Input/Output
A9	VSS	Power/Other	—
A10	D8#	Source Synch	Input/Output
A11	D9#	Source Synch	Input/Output
A12	VSS	Power/Other	—
A13	COMP0	Power/Other	Input
A14	D50#	Source Synch	Input/Output
A15	VSS	Power/Other	—
A16	DSTBN3#	Source Synch	Input/Output
A17	D56#	Source Synch	Input/Output
A18	VSS	Power/Other	—
A19	D61#	Source Synch	Input/Output
A20	RESERVED	—	—
A21	VSS	Power/Other	—
A22	D62#	Source Synch	Input/Output
A23	VCCA	Power/Other	—
A24	VSS	Power/Other	—
A25	VTT	Power/Other	—
A26	VTT	Power/Other	—
A27	VTT	Power/Other	—
A28	VTT	Power/Other	—
A29	VTT	Power/Other	—
A30	VTT	Power/Other	—
B1	VSS	Power/Other	—
B2	DBSY#	Common Clock	Input/Output
B3	RS0#	Common Clock	Input
B4	D0#	Source Synch	Input/Output
B5	VSS	Power/Other	—
B6	D5#	Source Synch	Input/Output
B7	D6#	Source Synch	Input/Output
B8	VSS	Power/Other	—
B9	DSTBP0#	Source Synch	Input/Output
B10	D10#	Source Synch	Input/Output
B11	VSS	Power/Other	—
B12	D13#	Source Synch	Input/Output
B13	RESERVED	—	—
B14	VSS	Power/Other	—
B15	D53#	Source Synch	Input/Output

Table 4-2. Numerical Land Assignments

Land #	Land Name	Signal Buffer Type	Direction
B16	D55#	Source Synch	Input/Output
B17	VSS	Power/Other	—
B18	D57#	Source Synch	Input/Output
B19	D60#	Source Synch	Input/Output
B20	VSS	Power/Other	—
B21	D59#	Source Synch	Input/Output
B22	D63#	Source Synch	Input/Output
B23	VSSA	Power/Other	—
B24	VSS	Power/Other	—
B25	VTT	Power/Other	—
B26	VTT	Power/Other	—
B27	VTT	Power/Other	—
B28	VTT	Power/Other	—
B29	VTT	Power/Other	—
B30	VTT	Power/Other	—
C1	DRDY#	Common Clock	Input/Output
C2	BNR#	Common Clock	Input/Output
C3	LOCK#	Common Clock	Input/Output
C4	VSS	Power/Other	—
C5	D1#	Source Synch	Input/Output
C6	D3#	Source Synch	Input/Output
C7	VSS	Power/Other	—
C8	DSTBN0#	Source Synch	Input/Output
C9	RESERVED	—	—
C10	VSS	Power/Other	—
C11	D11#	Source Synch	Input/Output
C12	D14#	Source Synch	Input/Output
C13	VSS	Power/Other	—
C14	D52#	Source Synch	Input/Output
C15	D51#	Source Synch	Input/Output
C16	VSS	Power/Other	—
C17	DSTBP3#	Source Synch	Input/Output
C18	D54#	Source Synch	Input/Output
C19	VSS	Power/Other	—
C20	DBI3#	Source Synch	Input/Output
C21	D58#	Source Synch	Input/Output
C22	VSS	Power/Other	—
C23	VCCIOPLL	Power/Other	—
C24	VSS	Power/Other	—
C25	VTT	Power/Other	—
C26	VTT	Power/Other	—
C27	VTT	Power/Other	—
C28	VTT	Power/Other	—
C29	VTT	Power/Other	—

**Table 4-2. Numerical Land Assignments**

Land #	Land Name	Signal Buffer Type	Direction
C30	VTT	Power/Other	—
D1	RESERVED	—	—
D2	ADS#	Common Clock	Input/Output
D3	VSS	Power/Other	—
D4	HIT#	Common Clock	Input/Output
D5	VSS	Power/Other	—
D6	VSS	Power/Other	—
D7	D20#	Source Synch	Input/Output
D8	D12#	Source Synch	Input/Output
D9	VSS	Power/Other	—
D10	D22#	Source Synch	Input/Output
D11	D15#	Source Synch	Input/Output
D12	VSS	Power/Other	—
D13	D25#	Source Synch	Input/Output
D14	RESERVED	—	—
D15	VSS	Power/Other	—
D16	RESERVED	—	—
D17	D49#	Source Synch	Input/Output
D18	VSS	Power/Other	—
D19	DBI2#	Source Synch	Input/Output
D20	D48#	Source Synch	Input/Output
D21	VSS	Power/Other	—
D22	D46#	Source Synch	Input/Output
D23	RESERVED	—	—
D24	VSS	Power/Other	—
D25	VTT	Power/Other	—
D26	VTT	Power/Other	—
D27	VTT	Power/Other	—
D28	VTT	Power/Other	—
D29	VTT	Power/Other	—
D30	VTT	Power/Other	—
E2	VSS	Power/Other	—
E3	TRDY#	Common Clock	Input
E4	HITM#	Common Clock	Input/Output
E5	RESERVED	—	—
E6	RESERVED	—	—
E7	RESERVED	—	—
E8	VSS	Power/Other	—
E9	D19#	Source Synch	Input/Output
E10	D21#	Source Synch	Input/Output
E11	VSS	Power/Other	—
E12	DSTBP1#	Source Synch	Input/Output
E13	D26#	Source Synch	Input/Output
E14	VSS	Power/Other	—

**Table 4-2. Numerical Land Assignments**

Land #	Land Name	Signal Buffer Type	Direction
E15	D33#	Source Synch	Input/Output
E16	D34#	Source Synch	Input/Output
E17	VSS	Power/Other	—
E18	D39#	Source Synch	Input/Output
E19	D40#	Source Synch	Input/Output
E20	VSS	Power/Other	—
E21	D42#	Source Synch	Input/Output
E22	D45#	Source Synch	Input/Output
E23	RESERVED	—	—
E24	RESERVED	—	—
E25	VSS	Power/Other	—
E26	VSS	Power/Other	—
E27	VSS	Power/Other	—
E28	VSS	Power/Other	—
E29	VSS	Power/Other	—
F2	EDRDY# <sup>1</sup>	Common Clock	Input
F3	BR0#	Common Clock	Input/Output
F4	VSS	Power/Other	—
F5	RS1#	Common Clock	Input
F6	RESERVED	—	—
F7	VSS	Power/Other	—
F8	D17#	Source Synch	Input/Output
F9	D18#	Source Synch	Input/Output
F10	VSS	Power/Other	—
F11	D23#	Source Synch	Input/Output
F12	D24#	Source Synch	Input/Output
F13	VSS	Power/Other	—
F14	D28#	Source Synch	Input/Output
F15	D30#	Source Synch	Input/Output
F16	VSS	Power/Other	—
F17	D37#	Source Synch	Input/Output
F18	D38#	Source Synch	Input/Output
F19	VSS	Power/Other	—
F20	D41#	Source Synch	Input/Output
F21	D43#	Source Synch	Input/Output
F22	VSS	Power/Other	—
F23	RESERVED	—	—
F24	TESTHI7	Power/Other	Input
F25	TESTHI2	Power/Other	Input
F26	TESTHI0	Power/Other	Input
F27	VTT_SEL	Power/Other	Output
F28	BCLK0	Clock	Input
F29	RESERVED	—	—
G1	VSS	Power/Other	—

Table 4-2. Numerical Land Assignments

Land #	Land Name	Signal Buffer Type	Direction
G2	COMP2	Power/Other	Input
G3	TESTHI8	Power/Other	Input
G4	TESTHI9	Power/Other	Input
G5	PC_REQ# <sup>1</sup>	Common Clock	Output
G6	RESERVED	—	—
G7	DEFER#	Common Clock	Input
G8	BPRI#	Common Clock	Input
G9	D16#	Source Synch	Input/Output
G10	RESERVED	—	—
G11	DBI1#	Source Synch	Input/Output
G12	DSTBN1#	Source Synch	Input/Output
G13	D27#	Source Synch	Input/Output
G14	D29#	Source Synch	Input/Output
G15	D31#	Source Synch	Input/Output
G16	D32#	Source Synch	Input/Output
G17	D36#	Source Synch	Input/Output
G18	D35#	Source Synch	Input/Output
G19	DSTBP2#	Source Synch	Input/Output
G20	DSTBN2#	Source Synch	Input/Output
G21	D44#	Source Synch	Input/Output
G22	D47#	Source Synch	Input/Output
G23	RESET#	Common Clock	Input
G24	TESTHI6	Power/Other	Input
G25	TESTHI3	Power/Other	Input
G26	TESTHI5	Power/Other	Input
G27	TESTHI4	Power/Other	Input
G28	BCLK1	Clock	Input
G29	BSEL0	Power/Other	Output
G30	BSEL2	Power/Other	Output
H1	GTLREF0	Power/Other	Input
H2	GTLREF1	—	—
H3	VSS	Power/Other	—
H4	RSP#	Common Clock	Input
H5	TESTHI10	Power/Other	Input
H6	VSS	Power/Other	—
H7	VSS	Power/Other	—
H8	VSS	Power/Other	—
H9	VSS	Power/Other	—
H10	VSS	Power/Other	—
H11	VSS	Power/Other	—
H12	VSS	Power/Other	—
H13	VSS	Power/Other	—
H14	VSS	Power/Other	—
H15	DP1#	Common Clock	Input/Output

Table 4-2. Numerical Land Assignments

Land #	Land Name	Signal Buffer Type	Direction
H16	DP2#	Common Clock	Input/Output
H17	VSS	Power/Other	—
H18	VSS	Power/Other	—
H19	VSS	Power/Other	—
H20	VSS	Power/Other	—
H21	VSS	Power/Other	—
H22	VSS	Power/Other	—
H23	VSS	Power/Other	—
H24	VSS	Power/Other	—
H25	VSS	Power/Other	—
H26	VSS	Power/Other	—
H27	VSS	Power/Other	—
H28	VSS	Power/Other	—
H29	GTLREF_SEL	Power/Other	—
H30	BSEL1	Power/Other	Output
J1	VTT_OUT_LEFT	Power/Other	Output
J2	COMP4	Power/Other	Input
J3	RESERVED	—	—
J4	VSS	Power/Other	—
J5	REQ1#	Source Synch	Input/Output
J6	REQ4#	Source Synch	Input/Output
J7	VSS	Power/Other	—
J8	VCC	Power/Other	—
J9	VCC	Power/Other	—
J10	VCC	Power/Other	—
J11	VCC	Power/Other	—
J12	VCC	Power/Other	—
J13	VCC	Power/Other	—
J14	VCC	Power/Other	—
J15	VCC	Power/Other	—
J16	DP0#	Common Clock	Input/Output
J17	DP3#	Common Clock	Input/Output
J18	VCC	Power/Other	—
J19	VCC	Power/Other	—
J20	VCC	Power/Other	—
J21	VCC	Power/Other	—
J22	VCC	Power/Other	—
J23	VCC	Power/Other	—
J24	VCC	Power/Other	—
J25	VCC	Power/Other	—
J26	VCC	Power/Other	—
J27	VCC	Power/Other	—
J28	VCC	Power/Other	—
J29	VCC	Power/Other	—

**Table 4-2. Numerical Land Assignments**

Land #	Land Name	Signal Buffer Type	Direction
J30	VCC	Power/Other	—
K1	LINT0	Asynch GTL+	Input
K2	VSS	Power/Other	—
K3	A20M#	Asynch GTL+	Input
K4	REQ0#	Source Synch	Input/Output
K5	VSS	Power/Other	—
K6	REQ3#	Source Synch	Input/Output
K7	VSS	Power/Other	—
K8	VCC	Power/Other	—
K23	VCC	Power/Other	—
K24	VCC	Power/Other	—
K25	VCC	Power/Other	—
K26	VCC	Power/Other	—
K27	VCC	Power/Other	—
K28	VCC	Power/Other	—
K29	VCC	Power/Other	—
K30	VCC	Power/Other	—
L1	LINT1	Asynch GTL+	Input
L2	TESTHI13	Power/Other	Input
L3	VSS	Power/Other	—
L4	A6#	Source Synch	Input/Output
L5	A3#	Source Synch	Input/Output
L6	VSS	Power/Other	—
L7	VSS	Power/Other	—
L8	VCC	Power/Other	—
L23	VSS	Power/Other	—
L24	VSS	Power/Other	—
L25	VSS	Power/Other	—
L26	VSS	Power/Other	—
L27	VSS	Power/Other	—
L28	VSS	Power/Other	—
L29	VSS	Power/Other	—
L30	VSS	Power/Other	—
M1	VSS	Power/Other	—
M2	THERMTRIP#	Asynch GTL+	Output
M3	STPCLK#	Asynch GTL+	Input
M4	A7#	Source Synch	Input/Output
M5	A5#	Source Synch	Input/Output
M6	REQ2#	Source Synch	Input/Output
M7	VSS	Power/Other	—
M8	VCC	Power/Other	—
M23	VCC	Power/Other	—
M24	VCC	Power/Other	—
M25	VCC	Power/Other	—

**Table 4-2. Numerical Land Assignments**

Land #	Land Name	Signal Buffer Type	Direction
M26	VCC	Power/Other	—
M27	VCC	Power/Other	—
M28	VCC	Power/Other	—
M29	VCC	Power/Other	—
M30	VCC	Power/Other	—
N1	PWRGOOD	Power/Other	Input
N2	IGNNE#	Asynch GTL+	Input
N3	VSS	Power/Other	—
N4	RESERVED	—	—
N5	RESERVED	—	—
N6	VSS	Power/Other	—
N7	VSS	Power/Other	—
N8	VCC	Power/Other	—
N23	VCC	Power/Other	—
N24	VCC	Power/Other	—
N25	VCC	Power/Other	—
N26	VCC	Power/Other	—
N27	VCC	Power/Other	—
N28	VCC	Power/Other	—
N29	VCC	Power/Other	—
N30	VCC	Power/Other	—
P1	TESTHI11	Power/Other	Input
P2	SMI#	Asynch GTL+	Input
P3	INIT#	Asynch GTL+	Input
P4	VSS	Power/Other	—
P5	RESERVED	—	—
P6	A4#	Source Synch	Input/Output
P7	VSS	Power/Other	—
P8	VCC	Power/Other	—
P23	VSS	Power/Other	—
P24	VSS	Power/Other	—
P25	VSS	Power/Other	—
P26	VSS	Power/Other	—
P27	VSS	Power/Other	—
P28	VSS	Power/Other	—
P29	VSS	Power/Other	—
P30	VSS	Power/Other	—
R1	COMP3	Power/Other	Input
R2	VSS	Power/Other	—
R3	FERR#/PBE#	Asynch GTL+	Output
R4	A8#	Source Synch	Input/Output
R5	VSS	Power/Other	—
R6	ADSTB0#	Source Synch	Input/Output
R7	VSS	Power/Other	—



Table 4-2. Numerical Land Assignments

Land #	Land Name	Signal Buffer Type	Direction
R8	VCC	Power/Other	—
R23	VSS	Power/Other	—
R24	VSS	Power/Other	—
R25	VSS	Power/Other	—
R26	VSS	Power/Other	—
R27	VSS	Power/Other	—
R28	VSS	Power/Other	—
R29	VSS	Power/Other	—
R30	VSS	Power/Other	—
T1	COMP1	Power/Other	Input
T2	COMP5	Power/Other	Input
T3	VSS	Power/Other	—
T4	A11#	Source Synch	Input/Output
T5	A9#	Source Synch	Input/Output
T6	VSS	Power/Other	—
T7	VSS	Power/Other	—
T8	VCC	Power/Other	—
T23	VCC	Power/Other	—
T24	VCC	Power/Other	—
T25	VCC	Power/Other	—
T26	VCC	Power/Other	—
T27	VCC	Power/Other	—
T28	VCC	Power/Other	—
T29	VCC	Power/Other	—
T30	VCC	Power/Other	—
U1	VSS	Power/Other	—
U2	AP0#	Common Clock	Input/Output
U3	AP1#	Common Clock	Input/Output
U4	A13#	Source Synch	Input/Output
U5	A12#	Source Synch	Input/Output
U6	A10#	Source Synch	Input/Output
U7	VSS	Power/Other	—
U8	VCC	Power/Other	—
U23	VCC	Power/Other	—
U24	VCC	Power/Other	—
U25	VCC	Power/Other	—
U26	VCC	Power/Other	—
U27	VCC	Power/Other	—
U28	VCC	Power/Other	—
U29	VCC	Power/Other	—
U30	VCC	Power/Other	—
V1	MS_ID1	Power/Other	Output
V2	LL_ID0	Power/Other	Output
V3	VSS	Power/Other	—

Table 4-2. Numerical Land Assignments

Land #	Land Name	Signal Buffer Type	Direction
V4	A15#	Source Synch	Input/Output
V5	A14#	Source Synch	Input/Output
V6	VSS	Power/Other	—
V7	VSS	Power/Other	—
V8	VCC	Power/Other	—
V23	VSS	Power/Other	—
V24	VSS	Power/Other	—
V25	VSS	Power/Other	—
V26	VSS	Power/Other	—
V27	VSS	Power/Other	—
V28	VSS	Power/Other	—
V29	VSS	Power/Other	—
V30	VSS	Power/Other	—
W1	MS_ID0	Power/Other	Output
W2	TESTHI12	Power/Other	Input
W3	TESTHI1	Power/Other	Input
W4	VSS	Power/Other	—
W5	A16#	Source Synch	Input/Output
W6	A18#	Source Synch	Input/Output
W7	VSS	Power/Other	—
W8	VCC	Power/Other	—
W23	VCC	Power/Other	—
W24	VCC	Power/Other	—
W25	VCC	Power/Other	—
W26	VCC	Power/Other	—
W27	VCC	Power/Other	—
W28	VCC	Power/Other	—
W29	VCC	Power/Other	—
W30	VCC	Power/Other	—
Y1	BOOTSELECT	Power/Other	Input
Y2	VSS	Power/Other	—
Y3	RESERVED	—	—
Y4	A20#	Source Synch	Input/Output
Y5	VSS	Power/Other	—
Y6	A19#	Source Synch	Input/Output
Y7	VSS	Power/Other	—
Y8	VCC	Power/Other	—
Y23	VCC	Power/Other	—
Y24	VCC	Power/Other	—
Y25	VCC	Power/Other	—
Y26	VCC	Power/Other	—
Y27	VCC	Power/Other	—
Y28	VCC	Power/Other	—
Y29	VCC	Power/Other	—

**Table 4-2. Numerical Land Assignments**

Land #	Land Name	Signal Buffer Type	Direction
Y30	VCC	Power/Other	—
AA1	VTT_OUT_RIGHT	Power/Other	Output
AA2	LL_ID1	Power/Other	Output
AA3	VSS	Power/Other	—
AA4	A21#	Source Synch	Input/Output
AA5	A23#	Source Synch	Input/Output
AA6	VSS	Power/Other	—
AA7	VSS	Power/Other	—
AA8	VCC	Power/Other	—
AA23	VSS	Power/Other	—
AA24	VSS	Power/Other	—
AA25	VSS	Power/Other	—
AA26	VSS	Power/Other	—
AA27	VSS	Power/Other	—
AA28	VSS	Power/Other	—
AA29	VSS	Power/Other	—
AA30	VSS	Power/Other	—
AB1	VSS	Power/Other	—
AB2	IERR#	Asynch GTL+	Output
AB3	MCERR#	Common Clock	Input/Output
AB4	A26#	Source Synch	Input/Output
AB5	A24#	Source Synch	Input/Output
AB6	A17#	Source Synch	Input/Output
AB7	VSS	Power/Other	—
AB8	VCC	Power/Other	—
AB23	VSS	Power/Other	—
AB24	VSS	Power/Other	—
AB25	VSS	Power/Other	—
AB26	VSS	Power/Other	—
AB27	VSS	Power/Other	—
AB28	VSS	Power/Other	—
AB29	VSS	Power/Other	—
AB30	VSS	Power/Other	—
AC1	TMS	TAP	Input
AC2	DBR#	Power/Other	Output
AC3	VSS	Power/Other	—
AC4	RESERVED	—	—
AC5	A25#	Source Synch	Input/Output
AC6	VSS	Power/Other	—
AC7	VSS	Power/Other	—
AC8	VCC	Power/Other	—
AC23	VCC	Power/Other	—
AC24	VCC	Power/Other	—
AC25	VCC	Power/Other	—

**Table 4-2. Numerical Land Assignments**

Land #	Land Name	Signal Buffer Type	Direction
AC26	VCC	Power/Other	—
AC27	VCC	Power/Other	—
AC28	VCC	Power/Other	—
AC29	VCC	Power/Other	—
AC30	VCC	Power/Other	—
AD1	TDI	TAP	Input
AD2	BPM2#	Common Clock	Input/Output
AD3	BINIT#	Common Clock	Input/Output
AD4	VSS	Power/Other	—
AD5	ADSTB1#	Source Synch	Input/Output
AD6	A22#	Source Synch	Input/Output
AD7	VSS	Power/Other	—
AD8	VCC	Power/Other	—
AD23	VCC	Power/Other	—
AD24	VCC	Power/Other	—
AD25	VCC	Power/Other	—
AD26	VCC	Power/Other	—
AD27	VCC	Power/Other	—
AD28	VCC	Power/Other	—
AD29	VCC	Power/Other	—
AD30	VCC	Power/Other	—
AE1	TCK	TAP	Input
AE2	VSS	Power/Other	—
AE3	RESERVED	—	—
AE4	RESERVED	—	—
AE5	VSS	Power/Other	—
AE6	RESERVED	—	—
AE7	VSS	Power/Other	—
AE8	SKTOCC#	Power/Other	Output
AE9	VCC	Power/Other	—
AE10	VSS	Power/Other	—
AE11	VCC	Power/Other	—
AE12	VCC	Power/Other	—
AE13	VSS	Power/Other	—
AE14	VCC	Power/Other	—
AE15	VCC	Power/Other	—
AE16	VSS	Power/Other	—
AE17	VSS	Power/Other	—
AE18	VCC	Power/Other	—
AE19	VCC	Power/Other	—
AE20	VSS	Power/Other	—
AE21	VCC	Power/Other	—
AE22	VCC	Power/Other	—
AE23	VCC	Power/Other	—

**Table 4-2. Numerical Land Assignments**

Land #	Land Name	Signal Buffer Type	Direction
AE24	VSS	Power/Other	—
AE25	VSS	Power/Other	—
AE26	VSS	Power/Other	—
AE27	VSS	Power/Other	—
AE28	VSS	Power/Other	—
AE29	VSS	Power/Other	—
AE30	VSS	Power/Other	—
AF1	TDO	TAP	Output
AF2	BPM4#	Common Clock	Input/Output
AF3	VSS	Power/Other	—
AF4	A28#	Source Synch	Input/Output
AF5	A27#	Source Synch	Input/Output
AF6	VSS	Power/Other	—
AF7	VSS	Power/Other	—
AF8	VCC	Power/Other	—
AF9	VCC	Power/Other	—
AF10	VSS	Power/Other	—
AF11	VCC	Power/Other	—
AF12	VCC	Power/Other	—
AF13	VSS	Power/Other	—
AF14	VCC	Power/Other	—
AF15	VCC	Power/Other	—
AF16	VSS	Power/Other	—
AF17	VSS	Power/Other	—
AF18	VCC	Power/Other	—
AF19	VCC	Power/Other	—
AF20	VSS	Power/Other	—
AF21	VCC	Power/Other	—
AF22	VCC	Power/Other	—
AF23	VSS	Power/Other	—
AF24	VSS	Power/Other	—
AF25	VSS	Power/Other	—
AF26	VSS	Power/Other	—
AF27	VSS	Power/Other	—
AF28	VSS	Power/Other	—
AF29	VSS	Power/Other	—
AF30	VSS	Power/Other	—
AG1	TRST#	TAP	Input
AG2	BPM3#	Common Clock	Input/Output
AG3	BPM5#	Common Clock	Input/Output
AG4	A30#	Source Synch	Input/Output
AG5	A31#	Source Synch	Input/Output
AG6	A29#	Source Synch	Input/Output
AG7	VSS	Power/Other	—

**Table 4-2. Numerical Land Assignments**

Land #	Land Name	Signal Buffer Type	Direction
AG8	VCC	Power/Other	—
AG9	VCC	Power/Other	—
AG10	VSS	Power/Other	—
AG11	VCC	Power/Other	—
AG12	VCC	Power/Other	—
AG13	VSS	Power/Other	—
AG14	VCC	Power/Other	—
AG15	VCC	Power/Other	—
AG16	VSS	Power/Other	—
AG17	VSS	Power/Other	—
AG18	VCC	Power/Other	—
AG19	VCC	Power/Other	—
AG20	VSS	Power/Other	—
AG21	VCC	Power/Other	—
AG22	VCC	Power/Other	—
AG23	VSS	Power/Other	—
AG24	VSS	Power/Other	—
AG25	VCC	Power/Other	—
AG26	VCC	Power/Other	—
AG27	VCC	Power/Other	—
AG28	VCC	Power/Other	—
AG29	VCC	Power/Other	—
AG30	VCC	Power/Other	—
AH1	VSS	Power/Other	—
AH2	RESERVED	—	—
AH3	VSS	Power/Other	—
AH4	A32#	Source Synch	Input/Output
AH5	A33#	Source Synch	Input/Output
AH6	VSS	Power/Other	—
AH7	VSS	Power/Other	—
AH8	VCC	Power/Other	—
AH9	VCC	Power/Other	—
AH10	VSS	Power/Other	—
AH11	VCC	Power/Other	—
AH12	VCC	Power/Other	—
AH13	VSS	Power/Other	—
AH14	VCC	Power/Other	—
AH15	VCC	Power/Other	—
AH16	VSS	Power/Other	—
AH17	VSS	Power/Other	—
AH18	VCC	Power/Other	—
AH19	VCC	Power/Other	—
AH20	VSS	Power/Other	—
AH21	VCC	Power/Other	—

**Table 4-2. Numerical Land Assignments**

Land #	Land Name	Signal Buffer Type	Direction
AH22	VCC	Power/Other	—
AH23	VSS	Power/Other	—
AH24	VSS	Power/Other	—
AH25	VCC	Power/Other	—
AH26	VCC	Power/Other	—
AH27	VCC	Power/Other	—
AH28	VCC	Power/Other	—
AH29	VCC	Power/Other	—
AH30	VCC	Power/Other	—
AJ1	BPM1#	Common Clock	Input/Output
AJ2	BPM0#	Common Clock	Input/Output
AJ3	ITP_CLK1	TAP	Input
AJ4	VSS	Power/Other	—
AJ5	A34#	Source Synch	Input/Output
AJ6	A35#	Source Synch	Input/Output
AJ7	VSS	Power/Other	—
AJ8	VCC	Power/Other	—
AJ9	VCC	Power/Other	—
AJ10	VSS	Power/Other	—
AJ11	VCC	Power/Other	—
AJ12	VCC	Power/Other	—
AJ13	VSS	Power/Other	—
AJ14	VCC	Power/Other	—
AJ15	VCC	Power/Other	—
AJ16	VSS	Power/Other	—
AJ17	VSS	Power/Other	—
AJ18	VCC	Power/Other	—
AJ19	VCC	Power/Other	—
AJ20	VSS	Power/Other	—
AJ21	VCC	Power/Other	—
AJ22	VCC	Power/Other	—
AJ23	VSS	Power/Other	—
AJ24	VSS	Power/Other	—
AJ25	VCC	Power/Other	—
AJ26	VCC	Power/Other	—
AJ27	VSS	Power/Other	—
AJ28	VSS	Power/Other	—
AJ29	VSS	Power/Other	—
AJ30	VSS	Power/Other	—
AK1	THERMDC	Power/Other	—
AK2	VSS	Power/Other	—
AK3	ITP_CLK0	TAP	Input
AK4	VID4	Power/Other	Output
AK5	VSS	Power/Other	—

**Table 4-2. Numerical Land Assignments**

Land #	Land Name	Signal Buffer Type	Direction
AK6	RESERVED	—	—
AK7	VSS	Power/Other	—
AK8	VCC	Power/Other	—
AK9	VCC	Power/Other	—
AK10	VSS	Power/Other	—
AK11	VCC	Power/Other	—
AK12	VCC	Power/Other	—
AK13	VSS	Power/Other	—
AK14	VCC	Power/Other	—
AK15	VCC	Power/Other	—
AK16	VSS	Power/Other	—
AK17	VSS	Power/Other	—
AK18	VCC	Power/Other	—
AK19	VCC	Power/Other	—
AK20	VSS	Power/Other	—
AK21	VCC	Power/Other	—
AK22	VCC	Power/Other	—
AK23	VSS	Power/Other	—
AK24	VSS	Power/Other	—
AK25	VCC	Power/Other	—
AK26	VCC	Power/Other	—
AK27	VSS	Power/Other	—
AK28	VSS	Power/Other	—
AK29	VSS	Power/Other	—
AK30	VSS	Power/Other	—
AL1	THERMDA	Power/Other	—
AL2	PROCHOT#	Asynch GTL+	Input/Output
AL3	VSS	Power/Other	—
AL4	VID5	Power/Other	Output
AL5	VID1	Power/Other	Output
AL6	VID3	Power/Other	Output
AL7	VSS	Power/Other	—
AL8	VCC	Power/Other	—
AL9	VCC	Power/Other	—
AL10	VSS	Power/Other	—
AL11	VCC	Power/Other	—
AL12	VCC	Power/Other	—
AL13	VSS	Power/Other	—
AL14	VCC	Power/Other	—
AL15	VCC	Power/Other	—
AL16	VSS	Power/Other	—
AL17	VSS	Power/Other	—
AL18	VCC	Power/Other	—
AL19	VCC	Power/Other	—

Table 4-2. Numerical Land Assignments

Land #	Land Name	Signal Buffer Type	Direction
AL20	VSS	Power/Other	—
AL21	VCC	Power/Other	—
AL22	VCC	Power/Other	—
AL23	VSS	Power/Other	—
AL24	VSS	Power/Other	—
AL25	VCC	Power/Other	—
AL26	VCC	Power/Other	—
AL27	VSS	Power/Other	—
AL28	VSS	Power/Other	—
AL29	VCC	Power/Other	—
AL30	VCC	Power/Other	—
AM1	VSS	Power/Other	—
AM2	VID0	Power/Other	Output
AM3	VID2	Power/Other	Output
AM4	VSS	Power/Other	—
AM5	VID6	Power/Other	Output
AM6	VTPWRGD	Power/Other	Input
AM7	VID7	Power/Other	Output
AM8	VCC	Power/Other	—
AM9	VCC	Power/Other	—
AM10	VSS	Power/Other	—
AM11	VCC	Power/Other	—
AM12	VCC	Power/Other	—
AM13	VSS	Power/Other	—
AM14	VCC	Power/Other	—
AM15	VCC	Power/Other	—
AM16	VSS	Power/Other	—
AM17	VSS	Power/Other	—
AM18	VCC	Power/Other	—
AM19	VCC	Power/Other	—
AM20	VSS	Power/Other	—
AM21	VCC	Power/Other	—
AM22	VCC	Power/Other	—
AM23	VSS	Power/Other	—
AM24	VSS	Power/Other	—
AM25	VCC	Power/Other	—
AM26	VCC	Power/Other	—
AM27	VSS	Power/Other	—
AM28	VSS	Power/Other	—
AM29	VCC	Power/Other	—
AM30	VCC	Power/Other	—
AN1	VSS	Power/Other	—
AN2	VSS	Power/Other	—
AN3	VCC_SENSE	Power/Other	Output

Table 4-2. Numerical Land Assignments

Land #	Land Name	Signal Buffer Type	Direction
AN4	VSS_SENSE	Power/Other	Output
AN5	VCC_MB REGULATION	Power/Other	Output
AN6	VSS_MB REGULATION	Power/Other	Output
AN7	VID_SELECT	Power/Other	Output
AN8	VCC	Power/Other	—
AN9	VCC	Power/Other	—
AN10	VSS	Power/Other	—
AN11	VCC	Power/Other	—
AN12	VCC	Power/Other	—
AN13	VSS	Power/Other	—
AN14	VCC	Power/Other	—
AN15	VCC	Power/Other	—
AN16	VSS	Power/Other	—
AN17	VSS	Power/Other	—
AN18	VCC	Power/Other	—
AN19	VCC	Power/Other	—
AN20	VSS	Power/Other	—
AN21	VCC	Power/Other	—
AN22	VCC	Power/Other	—
AN23	VSS	Power/Other	—
AN24	VSS	Power/Other	—
AN25	VCC	Power/Other	—
AN26	VCC	Power/Other	—
AN27	VSS	Power/Other	—
AN28	VSS	Power/Other	—
AN29	VCC	Power/Other	—
AN30	VCC	Power/Other	—

**NOTES:**

1. EDRDY# and PC\_REQ# are not features of the Celeron D processor in the 775-land package. They are included here for future processor compatibility.

## 4.2 Alphabetical Signals Reference

Table 4-3. Signal Description (Sheet 1 of 9)

Name	Type	Description												
A[35:3]#	Input/ Output	<p>A[35:3]# (Address) define a 2<sup>36</sup>-byte physical memory address space. In sub-phase 1 of the address phase, these signals transmit the address of a transaction. In sub-phase 2, these signals transmit transaction type information. These signals must connect the appropriate pins/lands of all agents on the processor FSB. A[35:3]# are protected by parity signals AP[1:0]#. A[35:3]# are source synchronous signals and are latched into the receiving buffers by ADSTB[1:0]#.</p> <p>On the active-to-inactive transition of RESET#, the processor samples a subset of the A[35:3]# signals to determine power-on configuration. See <a href="#">Section 6.1</a> for more details.</p>												
A20M#	Input	<p>If A20M# (Address-20 Mask) is asserted, the processor masks physical address bit 20 (A20#) before looking up a line in any internal cache and before driving a read/write transaction on the bus. Asserting A20M# emulates the 8086 processor's address wrap-around at the 1-MB boundary. Assertion of A20M# is only supported in real mode.</p> <p>A20M# is an asynchronous signal. However, to ensure recognition of this signal following an Input/Output write instruction, it must be valid along with the TRDY# assertion of the corresponding Input/Output Write bus transaction.</p>												
ADS#	Input/ Output	<p>ADS# (Address Strobe) is asserted to indicate the validity of the transaction address on the A[35:3]# and REQ[4:0]# signals. All bus agents observe the ADS# activation to begin parity checking, protocol checking, address decode, internal snoop, or deferred reply ID match operations associated with the new transaction.</p>												
ADSTB[1:0]#	Input/ Output	<p>Address strobes are used to latch A[35:3]# and REQ[4:0]# on their rising and falling edges. Strobes are associated with signals as shown below.</p> <table border="0" style="margin-left: auto; margin-right: auto;"> <thead> <tr> <th style="text-align: center;">Signals</th> <th style="text-align: center;">Associated Strobe</th> </tr> </thead> <tbody> <tr> <td style="text-align: center;">REQ[4:0]#, A[16:3]#</td> <td style="text-align: center;">ADSTB0#</td> </tr> <tr> <td style="text-align: center;">A[35:17]#</td> <td style="text-align: center;">ADSTB1#</td> </tr> </tbody> </table>	Signals	Associated Strobe	REQ[4:0]#, A[16:3]#	ADSTB0#	A[35:17]#	ADSTB1#						
Signals	Associated Strobe													
REQ[4:0]#, A[16:3]#	ADSTB0#													
A[35:17]#	ADSTB1#													
AP[1:0]#	Input/ Output	<p>AP[1:0]# (Address Parity) are driven by the request initiator along with ADS#, A[35:3]#, and the transaction type on the REQ[4:0]#. A correct parity signal is high if an even number of covered signals are low and low if an odd number of covered signals are low. This allows parity to be high when all the covered signals are high. AP[1:0]# should connect the appropriate pins/lands of all Celeron D processor in the 775-land package FSB agents. The following table defines the coverage model of these signals.</p> <table border="0" style="margin-left: auto; margin-right: auto;"> <thead> <tr> <th style="text-align: center;">Request Signals</th> <th style="text-align: center;">Subphase 1</th> <th style="text-align: center;">Subphase 2</th> </tr> </thead> <tbody> <tr> <td style="text-align: center;">A[35:24]#</td> <td style="text-align: center;">AP0#</td> <td style="text-align: center;">AP1#</td> </tr> <tr> <td style="text-align: center;">A[23:3]#</td> <td style="text-align: center;">AP1#</td> <td style="text-align: center;">AP0#</td> </tr> <tr> <td style="text-align: center;">REQ[4:0]#</td> <td style="text-align: center;">AP1#</td> <td style="text-align: center;">AP0#</td> </tr> </tbody> </table>	Request Signals	Subphase 1	Subphase 2	A[35:24]#	AP0#	AP1#	A[23:3]#	AP1#	AP0#	REQ[4:0]#	AP1#	AP0#
Request Signals	Subphase 1	Subphase 2												
A[35:24]#	AP0#	AP1#												
A[23:3]#	AP1#	AP0#												
REQ[4:0]#	AP1#	AP0#												

Table 4-3. Signal Description (Sheet 2 of 9)

Name	Type	Description
BCLK[1:0]	Input	The differential pair BCLK (Bus Clock) determines the FSB frequency. All processor FSB agents must receive these signals to drive their outputs and latch their inputs. All external timing parameters are specified with respect to the rising edge of BCLK0 crossing $V_{CROSS}$ .
BINIT#	Input/ Output	BINIT# (Bus Initialization) may be observed and driven by all processor FSB agents and if used, must connect the appropriate pins/lands of all such agents. If the BINIT# driver is enabled during power-on configuration, BINIT# is asserted to signal any bus condition that prevents reliable future operation. If BINIT# observation is enabled during power-on configuration, and BINIT# is sampled asserted, symmetric agents reset their bus LOCK# activity and bus request arbitration state machines. The bus agents do not reset their IOQ and transaction tracking state machines upon observation of BINIT# activation. Once the BINIT# assertion has been observed, the bus agents will re-arbitrate for the FSB and attempt completion of their bus queue and IOQ entries. If BINIT# observation is disabled during power-on configuration, a central agent may handle an assertion of BINIT# as appropriate to the error handling architecture of the system.
BNR#	Input/ Output	BNR# (Block Next Request) is used to assert a bus stall by any bus agent who is unable to accept new bus transactions. During a bus stall, the current bus owner cannot issue any new transactions.
BOOTSELECT	Input	This input is required to determine whether the processor is installed in a platform that supports the Celeron D processor in the 775-land package. The Celeron D processor in the 775-land package will not operate if this signal is low. This input has a weak internal pull-up to $V_{TT}$ .
BPM[5:0]#	Input/ Output	BPM[5:0]# (Breakpoint Monitor) are breakpoint and performance monitor signals. They are outputs from the processor that indicate the status of breakpoints and programmable counters used for monitoring processor performance. BPM[5:0]# should connect the appropriate pins/lands of all processor FSB agents. BPM4# provides PRDY# (Probe Ready) functionality for the TAP port. PRDY# is a processor output used by debug tools to determine processor debug readiness. BPM5# provides PREQ# (Probe Request) functionality for the TAP port. PREQ# is used by debug tools to request debug operation of the processor. These signals do not have on-die termination. Refer to <a href="#">Section 2.5</a> for termination requirements.
BPRI#	Input	BPRI# (Bus Priority Request) is used to arbitrate for ownership of the processor FSB. It must connect the appropriate pins/lands of all processor FSB agents. Observing BPRI# active (as asserted by the priority agent) causes all other agents to stop issuing new requests, unless such requests are part of an ongoing locked operation. The priority agent keeps BPRI# asserted until all of its requests are completed, then releases the bus by de-asserting BPRI#.
BR0#	Input/ Output	BR0# drives the BREQ0# signal in the system and is used by the processor to request the bus. During power-on configuration this signal is sampled to determine the agent ID = 0. This signal does not have on-die termination and must be terminated.
BSEL[2:0]	Output	The BCLK[1:0] frequency select signals BSEL[2:0] are used to select the processor input clock frequency. <a href="#">Table 2-6</a> defines the possible combinations of the signals and the frequency associated with each combination. The required frequency is determined by the processor, chipset, and clock synthesizer. All agents must operate at the same frequency. For more information about these signals, refer to <a href="#">Section 2.9</a> .

Table 4-3. Signal Description (Sheet 3 of 9)

Name	Type	Description															
COMP[1:0]	Analog	COMP[1:0] must be terminated to $V_{SS}$ on the system board using precision resistors.															
COMP[3:2]	Analog	For future processor compatibility COMP[3:2] must be terminated to $V_{TT}$ on the system board using precision resistors.															
COMP[5:4]	Analog	For future processor compatibility, COMP[5:4] must be terminated to $V_{TT}$ on the system board using precision resistors.															
D[63:0]#	Input/ Output	<p>D[63:0]# (Data) are the data signals. These signals provide a 64-bit data path between the processor FSB agents, and must connect the appropriate pins/lands on all such agents. The data driver asserts DRDY# to indicate a valid data transfer.</p> <p>D[63:0]# are quad-pumped signals and will thus be driven four times in a common clock period. D[63:0]# are latched off the falling edge of both DSTBP[3:0]# and DSTBN[3:0]#. Each group of 16 data signals correspond to a pair of one DSTBP# and one DSTBN#. The following table shows the grouping of data signals to data strobes and DBI#.</p> <p>Quad-Pumped Signal Groups</p> <table border="1"> <thead> <tr> <th>Data Group</th> <th>DSTBN#/ DSTBP#</th> <th>DBI#</th> </tr> </thead> <tbody> <tr> <td>D[15:0]#</td> <td>0</td> <td>0</td> </tr> <tr> <td>D[31:16]#</td> <td>1</td> <td>1</td> </tr> <tr> <td>D[47:32]#</td> <td>2</td> <td>2</td> </tr> <tr> <td>D[63:48]#</td> <td>3</td> <td>3</td> </tr> </tbody> </table> <p>Furthermore, the DBI# signals determine the polarity of the data signals. Each group of 16 data signals corresponds to one DBI# signal. When the DBI# signal is active, the corresponding data group is inverted and therefore sampled active high.</p>	Data Group	DSTBN#/ DSTBP#	DBI#	D[15:0]#	0	0	D[31:16]#	1	1	D[47:32]#	2	2	D[63:48]#	3	3
Data Group	DSTBN#/ DSTBP#	DBI#															
D[15:0]#	0	0															
D[31:16]#	1	1															
D[47:32]#	2	2															
D[63:48]#	3	3															
DBI[3:0]#	Input/ Output	<p>DBI[3:0]# (Data Bus Inversion) are source synchronous and indicate the polarity of the D[63:0]# signals. The DBI[3:0]# signals are activated when the data on the data bus is inverted. If more than half the data bits, within a 16-bit group, would have been asserted electrically low, the bus agent may invert the data bus signals for that particular sub-phase for that 16-bit group.</p> <p>DBI[3:0] Assignment To Data Bus</p> <table border="1"> <thead> <tr> <th>Bus Signal</th> <th>Data Bus Signals</th> </tr> </thead> <tbody> <tr> <td>DBI3#</td> <td>D[63:48]#</td> </tr> <tr> <td>DBI2#</td> <td>D[47:32]#</td> </tr> <tr> <td>DBI1#</td> <td>D[31:16]#</td> </tr> <tr> <td>DBI0#</td> <td>D[15:0]#</td> </tr> </tbody> </table>	Bus Signal	Data Bus Signals	DBI3#	D[63:48]#	DBI2#	D[47:32]#	DBI1#	D[31:16]#	DBI0#	D[15:0]#					
Bus Signal	Data Bus Signals																
DBI3#	D[63:48]#																
DBI2#	D[47:32]#																
DBI1#	D[31:16]#																
DBI0#	D[15:0]#																
DBR#	Output	DBR# is used only in processor systems where no debug port is implemented on the system board. DBR# is used by a debug port interposer so that an in-target probe can drive system reset. If a debug port is implemented in the system, DBR# is a no connect in the system. DBR# is not a processor signal.															
DBSY#	Input/ Output	DBSY# (Data Bus Busy) is asserted by the agent responsible for driving data on the processor FSB to indicate that the data bus is in use. The data bus is released after DBSY# is de-asserted. This signal must connect the appropriate pins/lands on all processor FSB agents.															



Table 4-3. Signal Description (Sheet 4 of 9)

Name	Type	Description										
DEFER#	Input	DEFER# is asserted by an agent to indicate that a transaction cannot be guaranteed in-order completion. Assertion of DEFER# is normally the responsibility of the addressed memory or Input/Output agent. This signal must connect the appropriate pins/lands of all processor FSB agents.										
DP[3:0]#	Input/Output	DP[3:0]# (Data Parity) provide parity protection for the D[63:0]# signals. They are driven by the agent responsible for driving D[63:0]#, and must connect the appropriate pins/lands of all processor FSB agents.										
DRDY#	Input/Output	DRDY# (Data Ready) is asserted by the data driver on each data transfer, indicating valid data on the data bus. In a multi-common clock data transfer, DRDY# may be de-asserted to insert idle clocks. This signal must connect the appropriate pins/lands of all processor FSB agents.										
DSTBN[3:0]#	Input/Output	Data strobe used to latch in D[63:0]#. <table border="1" style="margin-left: auto; margin-right: auto;"> <thead> <tr> <th>Signals</th> <th>Associated Strobe</th> </tr> </thead> <tbody> <tr> <td>D[15:0]#, DBI0#</td> <td>DSTBN0#</td> </tr> <tr> <td>D[31:16]#, DBI1#</td> <td>DSTBN1#</td> </tr> <tr> <td>D[47:32]#, DBI2#</td> <td>DSTBN2#</td> </tr> <tr> <td>D[63:48]#, DBI3#</td> <td>DSTBN3#</td> </tr> </tbody> </table>	Signals	Associated Strobe	D[15:0]#, DBI0#	DSTBN0#	D[31:16]#, DBI1#	DSTBN1#	D[47:32]#, DBI2#	DSTBN2#	D[63:48]#, DBI3#	DSTBN3#
Signals	Associated Strobe											
D[15:0]#, DBI0#	DSTBN0#											
D[31:16]#, DBI1#	DSTBN1#											
D[47:32]#, DBI2#	DSTBN2#											
D[63:48]#, DBI3#	DSTBN3#											
DSTBP[3:0]#	Input/Output	Data strobe used to latch in D[63:0]#. <table border="1" style="margin-left: auto; margin-right: auto;"> <thead> <tr> <th>Signals</th> <th>Associated Strobe</th> </tr> </thead> <tbody> <tr> <td>D[15:0]#, DBI0#</td> <td>DSTBP0#</td> </tr> <tr> <td>D[31:16]#, DBI1#</td> <td>DSTBP1#</td> </tr> <tr> <td>D[47:32]#, DBI2#</td> <td>DSTBP2#</td> </tr> <tr> <td>D[63:48]#, DBI3#</td> <td>DSTBP3#</td> </tr> </tbody> </table>	Signals	Associated Strobe	D[15:0]#, DBI0#	DSTBP0#	D[31:16]#, DBI1#	DSTBP1#	D[47:32]#, DBI2#	DSTBP2#	D[63:48]#, DBI3#	DSTBP3#
Signals	Associated Strobe											
D[15:0]#, DBI0#	DSTBP0#											
D[31:16]#, DBI1#	DSTBP1#											
D[47:32]#, DBI2#	DSTBP2#											
D[63:48]#, DBI3#	DSTBP3#											
EDRDY#	Input	This signal indicates to the processor that the memory controller is about to drive data on the bus based on a read request. The signal is driven from the memory controller one BCLK[1:0] prior to data being driven on the bus. EDRDY# is not a feature of the Celeron D processor in the 775-land package. It is included here for future processor compatibility.										
FERR#/PBE#	Output	FERR#/PBE# (Floating Point Error/Pending Break Event) is a multiplexed signal and its meaning is qualified by STPCLK#. When STPCLK# is not asserted, FERR#/PBE# indicates a floating-point error and will be asserted when the processor detects an unmasked floating-point error. When STPCLK# is not asserted, FERR#/PBE# is similar to the ERROR# signal on the Intel 387 coprocessor, and is included for compatibility with systems using MS-DOS*-type floating-point error reporting. When STPCLK# is asserted, an assertion of FERR#/PBE# indicates that the processor has a pending break event waiting for service. The assertion of FERR#/PBE# indicates that the processor should be returned to the Normal state. For additional information on the pending break event functionality, including the identification of support of the feature and enable/disable information, refer to volume 3 of the <i>Intel Architecture Software Developer's Manual</i> and the <i>Intel Processor Identification and the CPUID Instruction</i> application note.										
GTLREF[1:0]	Input	GTLREF0 determines the signal reference level for GTL+ input signals. GTLREF1 is not a feature of the Celeron D processor in the 775-Land package. It is included here for future processor compatibility. GTLREF0 is used by the GTL+ receivers to determine if a signal is a logical 0 or logical 1.										

Table 4-3. Signal Description (Sheet 5 of 9)

Name	Type	Description
GTLREF_SEL	Output	GTLREF_SEL is used to select the appropriate chipset GTLREF voltage.
HIT#	Input/ Output	HIT# (Snoop Hit) and HITM# (Hit Modified) convey transaction snoop operation results. Any FSB agent may assert both HIT# and HITM# together to indicate that it requires a snoop stall, which can be continued by reasserting HIT# and HITM# together.
HITM#	Input/ Output	
IERR#	Output	IERR# (Internal Error) is asserted by a processor as the result of an internal error. Assertion of IERR# is usually accompanied by a SHUTDOWN transaction on the processor FSB. This transaction may optionally be converted to an external error signal (e.g., NMI) by system core logic. The processor will keep IERR# asserted until the assertion of RESET#.  This signal does not have on-die termination. Refer to <a href="#">Section 2.5</a> for termination requirements.
IGNNE#	Input	IGNNE# (Ignore Numeric Error) is asserted to force the processor to ignore a numeric error and continue to execute noncontrol floating-point instructions. If IGNNE# is de-asserted, the processor generates an exception on a noncontrol floating-point instruction if a previous floating-point instruction caused an error. IGNNE# has no effect when the NE bit in control register 0 (CRO) is set.  IGNNE# is an asynchronous signal. However, to ensure recognition of this signal following an input/output write instruction, it must be valid along with the TRDY# assertion of the corresponding Input/Output Write bus transaction.
INIT#	Input	INIT# (Initialization), when asserted, resets integer registers inside the processor without affecting its internal caches or floating-point registers. The processor then begins execution at the power-on Reset vector configured during power-on configuration. The processor continues to handle snoop requests during INIT# assertion. INIT# is an asynchronous signal and must connect the appropriate pins/lands of all processor FSB agents.  If INIT# is sampled active on the active to inactive transition of RESET#, then the processor executes its Built-in Self-Test (BIST).
ITP_CLK[1:0]	Input	ITP_CLK[1:0] are copies of BCLK that are used only in processor systems where no debug port is implemented on the system board. ITP_CLK[1:0] are used as BCLK[1:0] references for a debug port implemented on an interposer. If a debug port is implemented in the system, ITP_CLK[1:0] are no connects in the system. These are not processor signals.
LINT[1:0]	Input	LINT[1:0] (Local APIC Interrupt) must connect the appropriate pins/lands of all APIC Bus agents. When the APIC is disabled, the LINT0 signal becomes INTR, a maskable interrupt request signal, and LINT1 becomes NMI, a nonmaskable interrupt. INTR and NMI are backward compatible with the signals of those names on the Pentium processor. Both signals are asynchronous.  Both of these signals must be software configured via BIOS programming of the APIC register space to be used either as NMI/INTR or LINT[1:0]. Because the APIC is enabled by default after Reset, operation of these signals as LINT[1:0] is the default configuration.
LL_ID[1:0]	Output	The LL_ID[1:0] signals are used to select the correct loadline slope for the processor.

Table 4-3. Signal Description (Sheet 6 of 9)

Name	Type	Description
LOCK#	Input/ Output	LOCK# indicates to the system that a transaction must occur atomically. This signal must connect the appropriate pins/lands of all processor FSB agents. For a locked sequence of transactions, LOCK# is asserted from the beginning of the first transaction to the end of the last transaction.  When the priority agent asserts BPRI# to arbitrate for ownership of the processor FSB, it will wait until it observes LOCK# de-asserted. This enables symmetric agents to retain ownership of the processor FSB throughout the bus locked operation and ensure the atomicity of lock.
MCERR#	Input/ Output	MCERR# (Machine Check Error) is asserted to indicate an unrecoverable error without a bus protocol violation. It may be driven by all processor FSB agents.  MCERR# assertion conditions are configurable at a system level. Assertion options are defined by the following options: <ul style="list-style-type: none"> <li>• Enabled or disabled.</li> <li>• Asserted, if configured, for internal errors along with IERR#.</li> <li>• Asserted, if configured, by the request initiator of a bus transaction after it observes an error.</li> <li>• Asserted by any bus agent when it observes an error in a bus transaction.</li> </ul> For more details regarding machine check architecture, refer to the <i>IA-32 Software Developer's Manual, Volume 3: System Programming Guide</i> .
MS_ID[1:0]	Output	These signals are provided to indicate the Market Segment for the processor and may be used for future processor compatibility or for keying.
PC_REQ#	Output	This signal provides an external bus indicator that the processor is done with the DRAM page and that the DRAM page could/should be closed. PC_REQ# is not a feature of the Celeron D processor in the 775-land package. It is included here for future processor compatibility.
PROCHOT#	Input/ Output	As an output, PROCHOT# (Processor Hot) will go active when the processor temperature monitoring sensor detects that the processor has reached its maximum safe operating temperature. This indicates that the processor Thermal Control Circuit (TCC) has been activated, if enabled. As an input, assertion of PROCHOT# by the system will activate the TCC, if enabled. The TCC will remain active until the system de-asserts PROCHOT#. See <a href="#">Section 5.2.4</a> for more details.
PWRGOOD	Input	PWRGOOD (Power Good) is a processor input. The processor requires this signal to be a clean indication that the clocks and power supplies are stable and within their specifications. 'Clean' implies that the signal will remain low (capable of sinking leakage current), without glitches, from the time that the power supplies are turned on until they come within specification. The signal must then transition monotonically to a high state. PWRGOOD can be driven inactive at any time, but clocks and power must again be stable before a subsequent rising edge of PWRGOOD.  The PWRGOOD signal must be supplied to the processor; it is used to protect internal circuits against voltage sequencing issues. It should be driven high throughout boundary scan operation.
REQ[4:0]#	Input/ Output	REQ[4:0]# (Request Command) must connect the appropriate pins/lands of all processor FSB agents. They are asserted by the current bus owner to define the currently active transaction type. These signals are source synchronous to ADSTB0#. Refer to the AP[1:0]# signal description for a details on parity checking of these signals.

Table 4-3. Signal Description (Sheet 7 of 9)

Name	Type	Description
RESET#	Input	<p>Asserting the RESET# signal resets the processor to a known state and invalidates its internal caches without writing back any of their contents. For a power-on Reset, RESET# must stay active for at least one millisecond after V<sub>CC</sub> and BCLK have reached their proper specifications. On observing active RESET#, all FSB agents will de-assert their outputs within two clocks. RESET# must not be kept asserted for more than 10 ms while PWRGOOD is asserted.</p> <p>A number of bus signals are sampled at the active-to-inactive transition of RESET# for power-on configuration. These configuration options are described in the <a href="#">Section 6.1</a>.</p> <p>This signal does not have on-die termination and must be terminated on the system board.</p>
RS[2:0]#	Input	RS[2:0]# (Response Status) are driven by the response agent (the agent responsible for completion of the current transaction), and must connect the appropriate pins/lands of all processor FSB agents.
RSP#	Input	<p>RSP# (Response Parity) is driven by the response agent (the agent responsible for completion of the current transaction) during assertion of RS[2:0]#, the signals for which RSP# provides parity protection. It must connect to the appropriate pins/lands of all processor FSB agents.</p> <p>A correct parity signal is high if an even number of covered signals are low and low if an odd number of covered signals are low. While RS[2:0]# = 000, RSP# is also high, since this indicates it is not being driven by any agent guaranteeing correct parity.</p>
SKTOCC#	Output	SKTOCC# (Socket Occupied) will be pulled to ground by the processor. System board designers may use this signal to determine if the processor is present.
SMI#	Input	<p>SMI# (System Management Interrupt) is asserted asynchronously by system logic. On accepting a System Management Interrupt, the processor saves the current state and enter System Management Mode (SMM). An SMI Acknowledge transaction is issued, and the processor begins program execution from the SMM handler.</p> <p>If SMI# is asserted during the de-assertion of RESET# the processor will tristate its outputs.</p>
STPCLK#	Input	STPCLK# (Stop Clock), when asserted, causes the processor to enter a low power Stop-Grant state. The processor issues a Stop-Grant Acknowledge transaction, and stops providing internal clock signals to all processor core units except the FSB and APIC units. The processor continues to snoop bus transactions and service interrupts while in Stop-Grant state. When STPCLK# is de-asserted, the processor restarts its internal clock to all units and resumes execution. The assertion of STPCLK# has no effect on the bus clock; STPCLK# is an asynchronous input.
TCK	Input	TCK (Test Clock) provides the clock input for the processor Test Bus (also known as the Test Access Port).
TDI	Input	TDI (Test Data In) transfers serial test data into the processor. TDI provides the serial input needed for JTAG specification support.
TDO	Output	TDO (Test Data Out) transfers serial test data out of the processor. TDO provides the serial output needed for JTAG specification support.
TESTHI[13:0]	Input	TESTHI[13:0] must be connected to a V <sub>TT</sub> power source through a resistor for proper processor operation. See <a href="#">Section 2.5</a> for more details.
THERMDA	Other	Thermal Diode Anode. See <a href="#">Section 5.2.7</a> .
THERMDC	Other	Thermal Diode Cathode. See <a href="#">Section 5.2.7</a> .

Table 4-3. Signal Description (Sheet 8 of 9)

Name	Type	Description						
THERMTRIP#	Output	In the event of a catastrophic cooling failure, the processor will automatically shut down when the silicon has reached a temperature approximately 20 °C above the maximum T <sub>C</sub> . Assertion of THERMTRIP# (Thermal Trip) indicates the processor junction temperature has reached a level beyond which permanent silicon damage may occur. Upon assertion of THERMTRIP#, the processor will shut off its internal clocks (thus halting program execution) in an attempt to reduce the processor junction temperature. To protect the processor, its core voltage (V <sub>CC</sub> ) must be removed following the assertion of THERMTRIP#. Driving of the THERMTRIP# signal is enabled within 10 μs of the assertion of PWRGOOD and is disabled on de-assertion of PWRGOOD. Once activated, THERMTRIP# remains latched until PWRGOOD is de-asserted. While the de-assertion of the PWRGOOD signal will de-assert THERMTRIP#, if the processor's junction temperature remains at or above the trip level, THERMTRIP# will again be asserted within 10 μs of the assertion of PWRGOOD.						
TMS	Input	TMS (Test Mode Select) is a JTAG specification support signal used by debug tools.						
TRDY#	Input	TRDY# (Target Ready) is asserted by the target to indicate that it is ready to receive a write or implicit writeback data transfer. TRDY# must connect the appropriate pins/lands of all FSB agents.						
TRST#	Input	TRST# (Test Reset) resets the Test Access Port (TAP) logic. TRST# must be driven low during power on Reset.						
VCC	Input	VCC are the power pins for the processor. The voltage supplied to these pins is determined by the VID[5:0] pins.						
VCCA	Input	VCCA provides isolated power for the internal processor core PLLs.						
VCCIOPLL	Input	VCCIOPLL provides isolated power for internal processor FSB PLLs. Follow the guidelines for VCCA.						
VCC_SENSE	Output	VCC_SENSE is an isolated low impedance connection to processor core power (V <sub>CC</sub> ). It can be used to sense or measure voltage near the silicon with little noise.						
VCC_MB_REGULATION	Output	This land is provided as a voltage regulator feedback sense point for V <sub>CC</sub> . It is connected internally in the processor package to the sense point land U27 as described in the <i>Voltage Regulator-Down (VRD) 10.1 Design Guide for Desktop Socket 775</i> .						
VID[7:0]	Output	VID[7:6] (Voltage ID) are not used by the Celeron D processor in the 775-Land package. These signals are included here for future processor compatibility.  VID[5:0] (Voltage ID) signals are used to support automatic selection of power supply voltages (V <sub>CC</sub> ). These are open drain signals that are driven by the Celeron D processor in the 775-land package and must be pulled up on the motherboard. Refer to the <i>Voltage Regulator-Down (VRD) 10.1 Design Guide for Desktop Socket 775</i> for more information. The voltage supply for these signals must be valid before the VR can supply V <sub>CC</sub> to the processor. Conversely, the VR output must be disabled until the voltage supply for the VID signals becomes valid. The VID signals are needed to support the processor voltage specification variations. See Table 2-2 for definitions of these signals. The VR must supply the voltage that is requested by the signals, or disable itself.						
VID_SELECT	Output	VID_SELECT is used to select the VID table that is to be used by the voltage regulator.  <table border="0" style="width: 100%; border-collapse: collapse;"> <thead> <tr> <th style="text-align: left; border-bottom: 1px solid black;">VID_SELECT</th> <th style="text-align: left; border-bottom: 1px solid black;">VR Table Used</th> </tr> </thead> <tbody> <tr> <td style="text-align: center;">L</td> <td style="text-align: center;">VRD10.1</td> </tr> <tr> <td style="text-align: center;">H</td> <td style="text-align: center;">VRD11</td> </tr> </tbody> </table>	VID_SELECT	VR Table Used	L	VRD10.1	H	VRD11
VID_SELECT	VR Table Used							
L	VRD10.1							
H	VRD11							

Table 4-3. Signal Description (Sheet 9 of 9)

Name	Type	Description						
VSS	Input	VSS are the ground pins for the processor and should be connected to the system ground plane.						
VSSA	Input	VSSA is the isolated ground for internal PLLs.						
VSS_SENSE	Output	VSS_SENSE is an isolated low impedance connection to processor core V <sub>SS</sub> . It can be used to sense or measure ground near the silicon with little noise.						
VSS_MB_REGULATION	Output	This land is provided as a voltage regulator feedback sense point for V <sub>SS</sub> . It is connected internally in the processor package to the sense point land V27 as described in the <i>Voltage Regulator-Down (VRD) 10.1 Design Guide for Desktop Socket 775</i> .						
VTT		FSB termination voltage.						
VTT_OUT_LEFT VTT_OUT_RIGHT	Output	<p>The VTT_OUT_LEFT and VTT_OUT_RIGHT signals are included to provide a local V<sub>TT</sub> for some signals that require termination to V<sub>TT</sub> on the motherboard.</p> <p>For future processor compatibility some signals are required to be pulled up to VTT_OUT_LEFT or VTT_OUT_RIGHT. Refer to the following table for the signals that should be pulled up to VTT_OUT_LEFT and VTT_OUT_RIGHT.</p> <table border="0"> <tr> <td style="vertical-align: top;"><b>Pull Up Signal</b></td> <td style="vertical-align: top;"><b>Signals to be Pulled Up</b></td> </tr> <tr> <td>VTT_OUT_RIGHT</td> <td>VTT_PWRGOOD, VID[5:0], GTLREF, TMS, TDI, TDO, BPM[5:0], other VRD components</td> </tr> <tr> <td>VTT_OUT_LEFT</td> <td>RESET#, BR0#, PWRGOOD, TESTHI1, TESTHI8, TESTHI9, TESTHI10, TESTHI11, TESTHI12, TESTHI13</td> </tr> </table>	<b>Pull Up Signal</b>	<b>Signals to be Pulled Up</b>	VTT_OUT_RIGHT	VTT_PWRGOOD, VID[5:0], GTLREF, TMS, TDI, TDO, BPM[5:0], other VRD components	VTT_OUT_LEFT	RESET#, BR0#, PWRGOOD, TESTHI1, TESTHI8, TESTHI9, TESTHI10, TESTHI11, TESTHI12, TESTHI13
<b>Pull Up Signal</b>	<b>Signals to be Pulled Up</b>							
VTT_OUT_RIGHT	VTT_PWRGOOD, VID[5:0], GTLREF, TMS, TDI, TDO, BPM[5:0], other VRD components							
VTT_OUT_LEFT	RESET#, BR0#, PWRGOOD, TESTHI1, TESTHI8, TESTHI9, TESTHI10, TESTHI11, TESTHI12, TESTHI13							
VTT_SEL	Output	The VTT_SEL signal is used to select the correct V <sub>TT</sub> voltage level for the processor.						
VTPWRGD	Input	The processor requires this input to determine that the V <sub>TT</sub> voltages are stable and within specification.						

§

# 5 Thermal Specifications and Design Considerations

---

## 5.1 Processor Thermal Specifications

The Celeron D processor in the 775-land package requires a thermal solution to maintain temperatures within operating limits as set forth in [Section 5.1.1](#). Any attempt to operate the processor outside these operating limits may result in permanent damage to the processor and potentially other components within the system. As processor technology changes, thermal management becomes increasingly crucial when building computer systems. Maintaining the proper thermal environment is key to reliable, long-term system operation.

A complete thermal solution includes both component and system level thermal management features. Component level thermal solutions can include active or passive heatsinks attached to the processor Integrated Heat Spreader (IHS). Typical system level thermal solutions may consist of system fans combined with ducting and venting.

For more information on designing a component level thermal solution, refer to the *Intel® Pentium® 4 Processor on 90 nm Process in the 775-Land LGA Package Thermal Design Guide*.

**Note:** The boxed processor will ship with a component thermal solution. Refer to [Chapter 7](#) for details on the boxed processor.

### 5.1.1 Thermal Specifications

To allow for the optimal operation and long-term reliability of Intel processor-based systems, the system/processor thermal solution should be designed such that the processor remains within the minimum and maximum case temperature ( $T_C$ ) specifications when operating at or below the Thermal Design Power (TDP) value listed per frequency in [Table 5-1](#). Thermal solutions not designed to provide this level of thermal capability may affect the long-term reliability of the processor and system. For more details on thermal solution design, refer to the appropriate processor thermal design guidelines.

The Celeron D processor in the 775-land package introduces a new methodology for managing processor temperatures that is intended to support acoustic noise reduction through fan speed control. Selection of the appropriate fan speed will be based on the temperature reported by the processor's Thermal Diode. If the diode temperature is greater than or equal to  $T_{CONTROL}$  then the processor case temperature must remain at or below the temperature as specified by the thermal profile. If the diode temperature is less than  $T_{CONTROL}$ , then the case temperature is permitted to exceed the thermal profile; however, the diode temperature must remain at or below  $T_{CONTROL}$ . Systems that implement fan speed control must be designed to take these conditions into account. Systems that do not alter the fan speed only need to guarantee the case temperature meets the thermal profile specifications.

To determine a processor's case temperature specification based on the thermal profile, it is necessary to accurately measure processor power dissipation. Intel has developed a methodology for accurate power measurement that correlates to Intel test temperature and voltage conditions.

Refer to the Intel® Pentium® 4 Processor on 90 nm Process in the 775-Land LGA Package Thermal Design Guide and the *Processor Power Characterization Methodology* for the details of this methodology.

The case temperature is defined at the geometric top center of the processor IHS. Analysis indicates that real applications are unlikely to cause the processor to consume maximum power dissipation for sustained periods of time. Intel recommends that complete thermal solution designs target the Thermal Design Power (TDP) indicated in [Table 5-1](#) instead of the maximum processor power consumption. The Thermal Monitor feature is intended to help protect the processor in the unlikely event that an application exceeds the TDP recommendation for a sustained period of time. For more details on the usage of this feature, refer to [Section 5.2](#). To ensure maximum flexibility for future requirements, systems should be designed to the Platform Compatibility Guide '04 A guidelines, even if a processor with a lower thermal dissipation is currently planned. **In all cases, the Thermal Monitor feature must be enabled for the processor to remain within specification.**

**Table 5-1. Processor Thermal Specifications**

Processor Number	Processor Core Frequency (GHz)	Thermal Design Power (W)	Minimum T <sub>C</sub> (°C)	Maximum T <sub>C</sub> (°C)	Notes
325J/326	2.53	84	5	See <a href="#">Table 5-2</a> and <a href="#">Figure 5-1</a>	1, 2
330J/331	2.66	84	5	See <a href="#">Table 5-2</a> and <a href="#">Figure 5-1</a>	1, 2
335J/336	2.80	84	5	See <a href="#">Table 5-2</a> and <a href="#">Figure 5-1</a>	1, 2
340J/341	2.93	84	5	See <a href="#">Table 5-2</a> and <a href="#">Figure 5-1</a>	1, 2
345J/346	3.06	84	5	See <a href="#">Table 5-2</a> and <a href="#">Figure 5-1</a>	1, 2
351	3.20	84	5	See <a href="#">Table 5-2</a> and <a href="#">Figure 5-1</a>	1, 2
355	3.33	84	5	See <a href="#">Table 5-2</a> and <a href="#">Figure 5-1</a>	1, 2

**NOTES:**

1. Thermal Design Power (TDP) should be used for processor thermal solution design targets. The TDP is not the maximum power that the processor can dissipate.
2. This table shows the maximum TDP for a given frequency range. Individual processors may have a lower TDP. Therefore, the maximum T<sub>C</sub> will vary depending on the TDP of the individual processor. Refer to thermal profile figure and associated table for the allowed combinations of power and T<sub>C</sub>.



Table 5-2. Thermal Profile for Processors

Power (W)	Maximum T <sub>C</sub> (°C)	Power (W)	Maximum T <sub>C</sub> (°C)	Power (W)	Maximum T <sub>C</sub> (°C)
0	44.2	30	52.6	60	61.0
2	44.8	32	53.2	62	61.6
4	45.3	34	53.7	64	62.1
6	45.9	36	54.3	66	62.7
8	46.4	38	54.8	68	63.2
10	47.0	40	55.4	70	63.8
12	47.6	42	56.0	72	64.4
14	48.1	44	56.5	74	64.9
16	48.7	46	57.1	76	65.5
18	49.2	48	57.6	78	66.0
20	49.8	50	58.2	80	66.6
22	50.4	52	58.8	82	67.2
24	50.9	54	59.3	84	67.7
26	51.5	56	59.9		
28	52.0	58	60.4		

Figure 5-1. Thermal Profile for Platform Compatibility Guide '04 A Processors

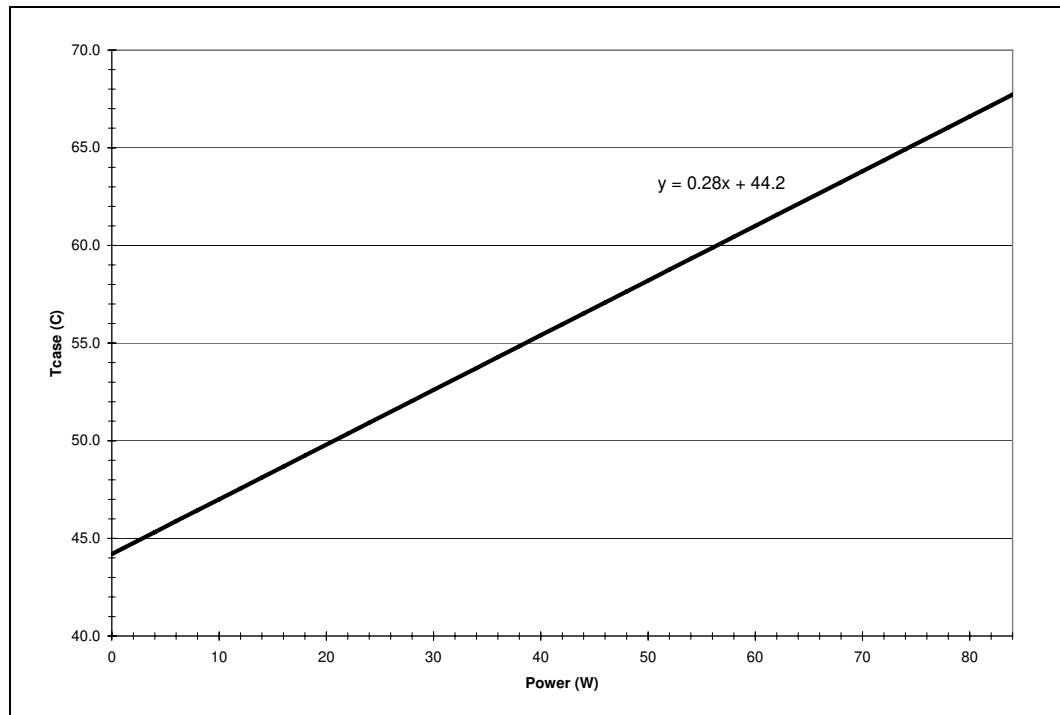

## 5.1.2 Thermal Metrology

The maximum and minimum case temperatures ( $T_C$ ) are specified in Table 5-1. These temperature specifications are meant to help ensure proper operation of the processor. Figure 5-2 illustrates where Intel recommends  $T_C$  thermal measurements should be made. For detailed guidelines on temperature measurement methodology, refer to the *Intel® Pentium® 4 Processor on 90 nm Process in the 775-Land LGA Package Thermal Design Guide*.

Figure 5-2. Case Temperature ( $T_C$ ) Measurement Location

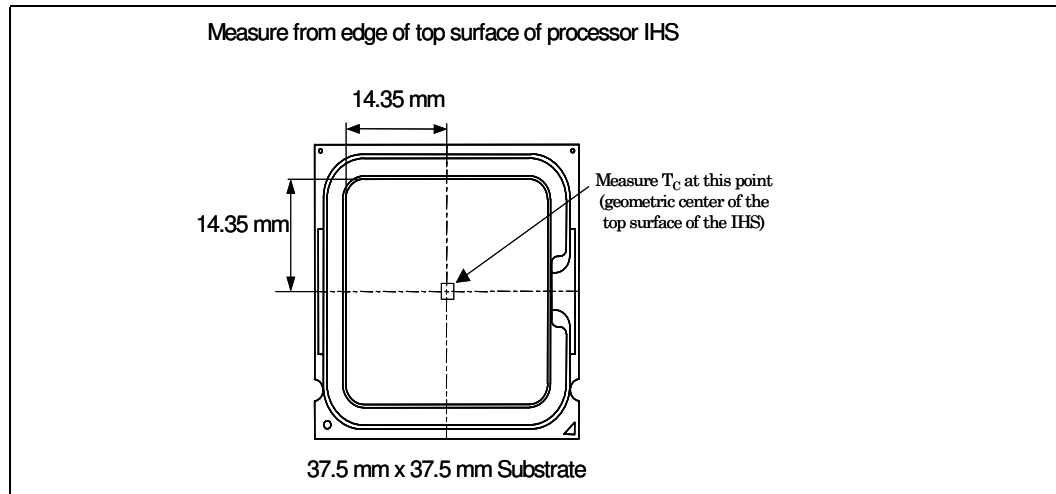

## 5.2 Processor Thermal Features

### 5.2.1 Thermal Monitor

The Thermal Monitor feature helps control the processor temperature by activating the TCC when the processor silicon reaches its maximum operating temperature. The TCC reduces processor power consumption as needed by modulating (starting and stopping) the internal processor core clocks. **The Thermal Monitor feature must be enabled for the processor to be operating within specifications.** The temperature at which Thermal Monitor activates the thermal control circuit is not user configurable and is not software visible. Bus traffic is snooped in the normal manner, and interrupt requests are latched (and serviced during the time that the clocks are on) while the TCC is active.

When the Thermal Monitor feature is enabled, and a high temperature situation exists (i.e., TCC is active), the clocks will be modulated by alternately turning the clocks off and on at a duty cycle specific to the processor (typically 30–50%). Clocks often will not be off for more than 3.0  $\mu$ s when the TCC is active. Cycle times are processor speed dependent and will decrease as processor core frequencies increase. A small amount of hysteresis has been included to prevent rapid active/inactive transitions of the TCC when the processor temperature is near its maximum operating temperature. Once the temperature has dropped below the maximum operating temperature, and the hysteresis timer has expired, the TCC goes inactive and clock modulation ceases.

With a properly designed and characterized thermal solution, it is anticipated that the TCC would only be activated for very short periods of time when running the most power intensive applications. The processor performance impact due to these brief periods of TCC activation is

expected to be so minor that it would be immeasurable. An under-designed thermal solution that is not able to prevent excessive activation of the TCC in the anticipated ambient environment may cause a noticeable performance loss, and in some cases may result in a  $T_C$  that exceeds the specified maximum temperature and may affect the long-term reliability of the processor. In addition, a thermal solution that is significantly under-designed may not be capable of cooling the processor even when the TCC is active continuously. Refer to the *Intel® Pentium® 4 Processor on 90 nm Process in the 775-Land LGA Package Thermal Design Guide* for information on designing a thermal solution.

The duty cycle for the TCC, when activated by the Thermal Monitor, is factory configured and cannot be modified. The Thermal Monitor does not require any additional hardware, software drivers, or interrupt handling routines.

## 5.2.2 Thermal Monitor 2

The Celeron D processor in the 775-land package also supports a power management capability known as Thermal Monitor 2. This mechanism provides an efficient mechanism for limiting the processor temperature by reducing power consumption within the processor.

When Thermal Monitor 2 is enabled, and a high temperature situation is detected, the enhanced Thermal Control Circuit (TCC) will be activated. This enhanced TCC causes the processor to adjust its operating frequency (bus multiplier) and input voltage (VID). This combination of reduced frequency and VID results in a decrease in processor power consumption.

A processor enabled for Thermal Monitor 2 includes two operating points, each consisting of a specific operating frequency and voltage. The first point represents the normal operating conditions for the processor.

The second point consists of both a lower operating frequency and voltage. When the enhanced TCC is activated, the processor automatically transitions to the new frequency. This transition occurs very rapidly (on the order of 5  $\mu$ s). During the frequency transition, the processor is unable to service any bus requests, and consequently, all bus traffic is blocked. Edge-triggered interrupts will be latched and kept pending until the processor resumes operation at the new frequency.

Once the new operating frequency is engaged, the processor will transition to the new core operating voltage by issuing a new VID code to the voltage regulator. The voltage regulator must support VID transitions to support Thermal Monitor 2. During the voltage change, it will be necessary to transition through multiple VID codes to reach the target operating voltage. Each step will be one VID table entry (i.e., 12.5 mV steps). The processor continues to execute instructions during the voltage transition. Operation at this lower voltage reduces both the dynamic and leakage power consumption of the processor, providing a reduction in power consumption at a minimum performance impact.

Once the processor has sufficiently cooled and a minimum activation time has expired, the operating frequency and voltage transition back to the normal system operating point. Transition of the VID code will occur first, to insure proper operation once the processor reaches its normal operating frequency. Refer to [Figure 5-3](#) for an illustration of this ordering.

Figure 5-3. Thermal Monitor 2 Frequency and Voltage Ordering

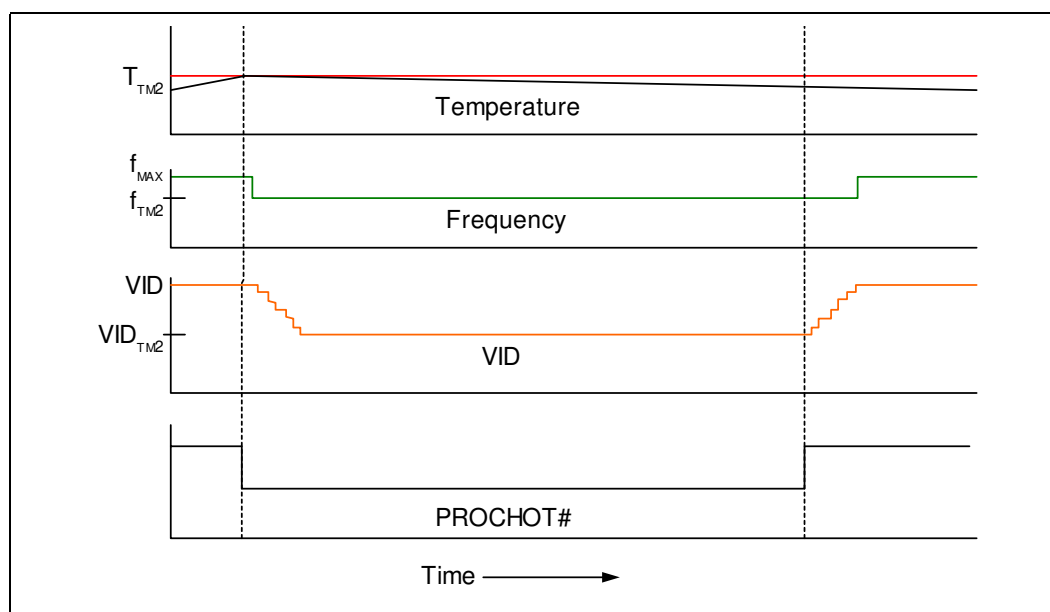

The PROCHOT# signal is asserted when a high temperature situation is detected, regardless of whether or not Thermal Monitor or Thermal Monitor 2 is enabled.

It should be noted that the Thermal Monitor 2 TCC can not be activated via the on demand mode. The Thermal Monitor TCC, however, can be activated through the use of the on-demand mode.

### 5.2.3 On-Demand Mode

The Celeron D processor in the 775-land package provides an auxiliary mechanism that allows system software to force the processor to reduce its power consumption. This mechanism is referred to as "On-Demand" mode and is distinct from the Thermal Monitor feature. On-Demand mode is intended as a means to reduce system level power consumption. Systems using the Celeron D processor in the 775-land package must not rely on software usage of this mechanism to limit the processor temperature.

If bit 4 of the ACPI P\_CNT Control Register (located in the processor IA32\_THERM\_CONTROL MSR) is written to a '1', the processor will immediately reduce its power consumption via modulation (starting and stopping) of the internal core clock, independent of the processor temperature. When using On-Demand mode, the duty cycle of the clock modulation is programmable via bits 3:1 of the same ACPI P\_CNT Control Register. In On-Demand mode, the duty cycle can be programmed from 12.5% on/ 87.5% off, to 87.5% on/12.5% off in 12.5% increments. On-Demand mode may be used in conjunction with the Thermal Monitor. If the system tries to enable On-Demand mode at the same time the TCC is engaged, the factory configured duty cycle of the TCC will override the duty cycle selected by the On-Demand mode.

## 5.2.4 PROCHOT# Signal

An external signal, PROCHOT# (processor hot), is asserted when the processor die temperature has reached its maximum operating temperature. If the Thermal Monitor is enabled (note that the Thermal Monitor must be enabled for the processor to be operating within specification), the TCC will be active when PROCHOT# is asserted. The processor can be configured to generate an interrupt upon the assertion or de-assertion of PROCHOT#. Refer to the *Intel Architecture Software Developer's Manuals* for specific register and programming details.

The Celeron D processor in the 775-land package implements a bi-directional PROCHOT# capability to allow system designs to protect various components from over-temperature situations. The PROCHOT# signal is bi-directional in that it can either signal when the processor has reached its maximum operating temperature or be driven from an external source to activate the TCC. The ability to activate the TCC via PROCHOT# can provide a means for thermal protection of system components.

One application is the thermal protection of voltage regulators (VR). System designers can create a circuit to monitor the VR temperature and activate the TCC when the temperature limit of the VR is reached. By asserting PROCHOT# (pulled-low) and activating the TCC, the VR can cool down as a result of reduced processor power consumption. Bi-directional PROCHOT# can allow VR thermal designs to target maximum sustained current instead of maximum current. Systems should still provide proper cooling for the VR, and rely on bi-directional PROCHOT# only as a backup in case of system cooling failure. The system thermal design should allow the power delivery circuitry to operate within its temperature specification even while the processor is operating at its Thermal Design Power. With a properly designed and characterized thermal solution, it is anticipated that bi-directional PROCHOT# would only be asserted for very short periods of time when running the most power intensive applications. An under-designed thermal solution that is not able to prevent excessive assertion of PROCHOT# in the anticipated ambient environment may cause a noticeable performance loss. Refer to the *Voltage Regulator-Down (VRD) 10.1 Design Guide for Desktop Socket 775* for details on implementing the bi-directional PROCHOT# feature.

## 5.2.5 THERMTRIP# Signal

Regardless of whether or not the Thermal Monitor feature is enabled, in the event of a catastrophic cooling failure, the processor will automatically shut down when the silicon has reached an elevated temperature (refer to the THERMTRIP# definition in [Table 4-3](#)). At this point, the FSB signal THERMTRIP# will go active and stay active as described in [Table 4-3](#). THERMTRIP# activation is independent of processor activity and does not generate any bus cycles.

## 5.2.6 T<sub>CONTROL</sub> and Fan Speed Reduction

T<sub>CONTROL</sub> is a temperature specification based on a temperature reading from the thermal diode. The value for T<sub>CONTROL</sub> will be calibrated in manufacturing and configured for each processor. When T<sub>DIODE</sub> is above T<sub>CONTROL</sub>, then T<sub>C</sub> must be at or below T<sub>C-MAX</sub> as defined by the thermal profile in [Table 5-2](#) and [Figure 5-1](#). Otherwise, the processor temperature can be maintained at T<sub>CONTROL</sub> (or lower) as measured by the thermal diode.

The purpose of this feature is to support acoustic optimization through fan speed control. Contact your Intel representative for further details and documentation.

## 5.2.7 Thermal Diode

The processor incorporates an on-die thermal diode. A thermal sensor located on the system board may monitor the die temperature of the processor for thermal management/long term die temperature change purposes. Table 5-3 and Table 5-4 provide the diode parameter and interface specifications. This thermal diode is separate from the Thermal Monitor’s thermal sensor and cannot be used to predict the behavior of the Thermal Monitor.

**Table 5-3. Thermal Diode Parameters**

Symbol	Parameter	Min	Typ	Max	Unit	Notes
$I_{FW}$	Forward Bias Current	11	—	187	$\mu A$	1
$n$	Diode Ideality Factor	1.0083	1.011	1.023	—	2, 3, 4, 5
$R_T$	Series Resistance	3.242	3.33	3.594	$\Omega$	2, 3, 6

**NOTES:**

- Intel does not support or recommend operation of the thermal diode under reverse bias.
- Characterized at 75 °C.
- Not 100% tested. Specified by design characterization.
- The ideality factor,  $n$ , represents the deviation from ideal diode behavior as exemplified by the diode equation:  

$$I_{FW} = I_S * (e^{qV_D/nkT} - 1)$$
 where  $I_S$  = saturation current,  $q$  = electronic charge,  $V_D$  = voltage across the diode,  $k$  = Boltzmann Constant, and  $T$  = absolute temperature (Kelvin).
- Devices found to have an ideality factor in the range of +3  $n$  to +5  $n$  will create a temperature error approximately 2° C higher than the actual temperature. To minimize any potential acoustic impact of this temperature error,  $T_{CONTROL}$  will be increased by 2° C on these parts. Processors with an ideality between  $\pm 3 n$  will not be affected.
- The series resistance,  $R_T$ , is provided to allow for a more accurate measurement of the diode temperature.  $R_T$ , as defined, includes the lands of the processor but does not include any socket resistance or board trace resistance between the socket and the external remote diode thermal sensor.  $R_T$  can be used by remote diode thermal sensors with automatic series resistance cancellation to calibrate out this error term. Another application is that a temperature offset can be manually calculated and programmed into an offset register in the remote diode thermal sensors as exemplified by the equation:  

$$T_{error} = [R_T * (N-1) * I_{FWmin}] / [nk/q * \ln N]$$
 where  $T_{error}$  = sensor temperature error,  $N$  = sensor current ratio,  $k$  = Boltzmann Constant,  $q$  = electronic charge.

**Table 5-4. Thermal Diode Interface**

Signal Name	Land Number	Signal Description
THERMDA	AL1	diode anode
THERMDC	AK1	diode cathode

§

# 6 Features

This chapter contains power-on configuration options and clock control/low power state descriptions.

## 6.1 Power-On Configuration Options

Several configuration options can be configured by hardware. The Celeron D processor in the 775-land package samples the hardware configuration at reset, on the active-to-inactive transition of RESET#. For specifications on these options, refer to [Table 6-1](#).

The sampled information configures the processor for subsequent operation. These configuration options cannot be changed except by another reset. All resets reconfigure the processor; for reset purposes, the processor does not distinguish between a "warm" reset and a "power-on" reset.

**Table 6-1. Power-On Configuration Option Signals**

Configuration Option	Signal <sup>1, 2</sup>
Output tristate	SMI#
Execute BIST	INIT#
In Order Queue pipelining (set IOQ depth to 1)	A7#
Disable MCERR# observation	A9#
Disable BINIT# observation	A10#
APIC Cluster ID (0-3)	A[12:11]#
Disable bus parking	A15#
Symmetric agent arbitration ID	BR0#
RESERVED	A[6:3]#, A8#, A[14:13]#, A[16:30]#, A[32:35]#

**NOTES:**

1. Asserting this signal during RESET# will select the corresponding option.
2. Address signals not identified in this table as configuration options should not be asserted during RESET#.

## 6.2 Clock Control and Low Power States

The processor allows the use of AutoHALT and Stop-Grant to reduce power consumption by stopping the clock to internal sections of the processor, depending on each particular state. See [Figure 6-1](#) for a visual representation of the processor low power states.

Figure 6-1. Processor Low Power State Machine

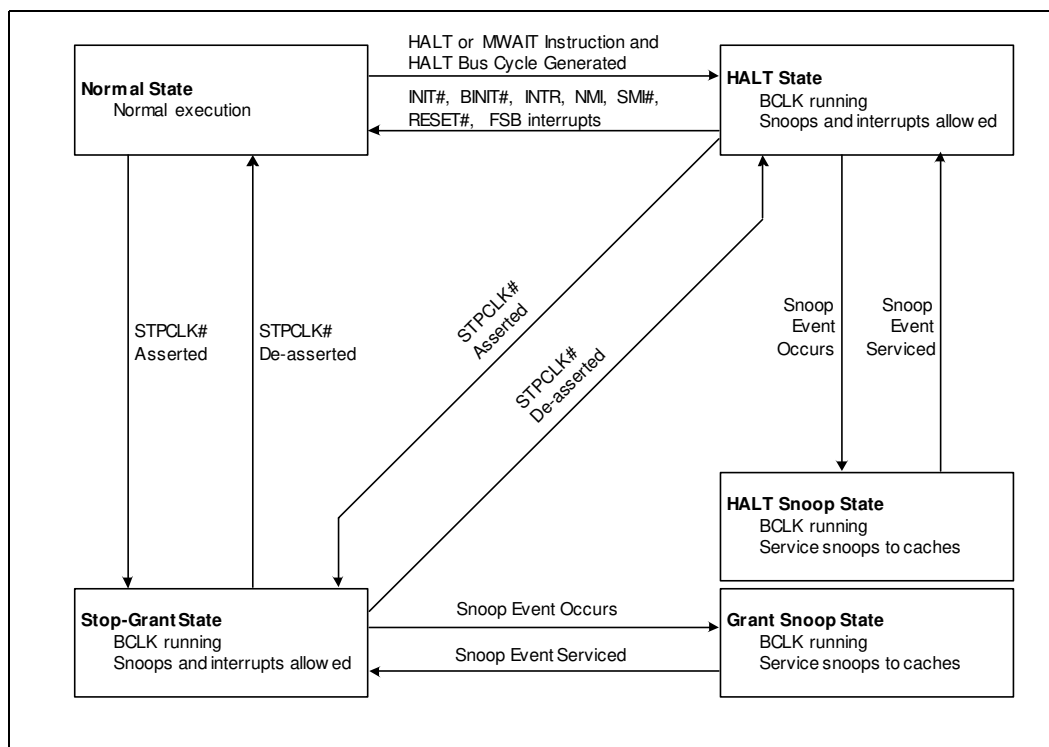

### 6.2.1 Normal State

This is the normal operating state for the processor.

### 6.2.2 HALT Powerdown State

HALT is a low power state entered when all the logical processors have executed the HALT or MWAIT instructions. When one of the logical processors executes the HALT instruction, that logical processor is halted; however, the other processor continues normal operation. The processor will transition to the Normal state upon the occurrence of SMI#, BINIT#, INIT#, or LINT[1:0] (NMI, INTR). RESET# will cause the processor to immediately initialize itself.

The return from a System Management Interrupt (SMI) handler can be to either Normal Mode or the HALT Power Down state. See the *Intel Architecture Software Developer's Manual, Volume III: System Programmer's Guide* for more information.

The system can generate a STPCLK# while the processor is in the HALT Power Down state. When the system de-asserts the STPCLK# interrupt, the processor will return execution to the HALT state.

While in HALT Power Down state, the processor will process bus snoops.



### 6.2.3 Stop-Grant States

When the STPCLK# signal is asserted, the Stop-Grant state of the processor is entered 20 bus clocks after the response phase of the processor-issued Stop Grant Acknowledge special bus cycle.

Since the GTL+ signals receive power from the FSB, these signals should not be driven (allowing the level to return to  $V_{TT}$ ) for minimum power drawn by the termination resistors in this state. In addition, all other input signals on the FSB should be driven to the inactive state.

BINIT# will not be serviced while the processor is in Stop-Grant state. The event will be latched and can be serviced by software upon exit from the Stop Grant state.

RESET# will cause the processor to immediately initialize itself, but the processor will stay in Stop-Grant state. A transition back to the Normal state will occur with the de-assertion of the STPCLK# signal.

A transition to the HALT/Grant Snoop state will occur when the processor detects a snoop on the FSB (see [Section 6.2.4](#)).

While in the Stop-Grant state, SMI#, INIT#, BINIT# and LINT[1:0] will be latched by the processor, and only serviced when the processor returns to the Normal state. Only one occurrence of each event will be recognized upon return to the Normal state.

While in Stop-Grant state, the processor will process a FSB snoop.

### 6.2.4 HALT Snoop State, Grant Snoop State

The processor will respond to snoop transactions on the FSB while in Stop-Grant state or in HALT Power Down state. During a snoop transaction, the processor enters the HALT:Grant Snoop state. The processor will stay in this state until the snoop on the FSB has been serviced (whether by the processor or another agent on the FSB). After the snoop is serviced, the processor will return to the Stop-Grant state or HALT Power Down state, as appropriate.

§



# 7 *Boxed Processor Specifications*

---

The Celeron D processor in the 775-land package will also be offered as an boxed Intel processor. Boxed Intel processors are intended for system integrators who build systems from baseboards and standard components. The boxed Celeron D processor in the 775-land package will be supplied with a cooling solution. This chapter documents baseboard and system requirements for the cooling solution that will be supplied with the boxed Celeron D processor in the 775-land package. This chapter is particularly important for OEMs that manufacture baseboards for system integrators. [Figure 7-1](#) shows a mechanical representation of a boxed Celeron D processor in the 775-land package.

**Note:** Unless otherwise noted, all figures in this chapter are dimensioned in millimeters and inches [in brackets].

**Note:** Drawings in this section reflect only the specifications on the boxed Intel processor product. These dimensions should not be used as a generic keep-out zone for all cooling solutions. It is the system designer's responsibility to consider their proprietary cooling solution when designing to the required keep-out zone on their system platforms and chassis. Refer to the *Intel® Pentium® 4 Processor on 90 nm Process in the 775-Land LGA Package Thermal Design Guide* for further guidance.

**Figure 7-1. Mechanical Representation of the Boxed Processor**

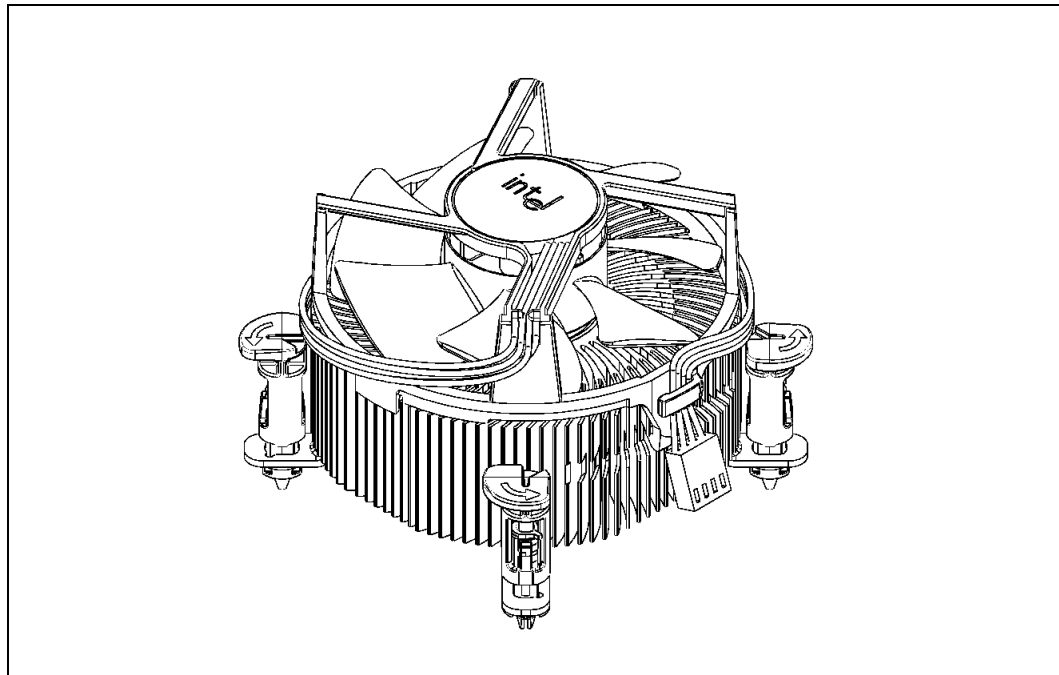

**NOTE:** The airflow of the fan heatsink is into the center and out of the sides of the fan heatsink.

## 7.1 Mechanical Specifications

### 7.1.1 Boxed Processor Cooling Solution Dimensions

This section documents the mechanical specifications of the boxed Celeron D processor in the 775-land package fan heatsink. The boxed processor will be shipped with an unattached fan heatsink. Figure 7-1 shows a mechanical representation of the boxed Pentium 4 processor in the 775-land package.

Clearance is required around the fan heatsink to ensure unimpeded airflow for proper cooling. The physical space requirements and dimensions for the boxed processor with assembled fan heatsink are shown in Figure 7-2 (Side View), and Figure 7-3 (Top View). The airspace requirements for the boxed processor fan heatsink must also be incorporated into new baseboard and system designs. Airspace requirements are shown in Figure 7-7 and Figure 7-8. Note that some figures have centerlines shown (marked with alphabetic designations) to clarify relative dimensioning.

Figure 7-2. Space Requirements for the Boxed Processor (Side View)

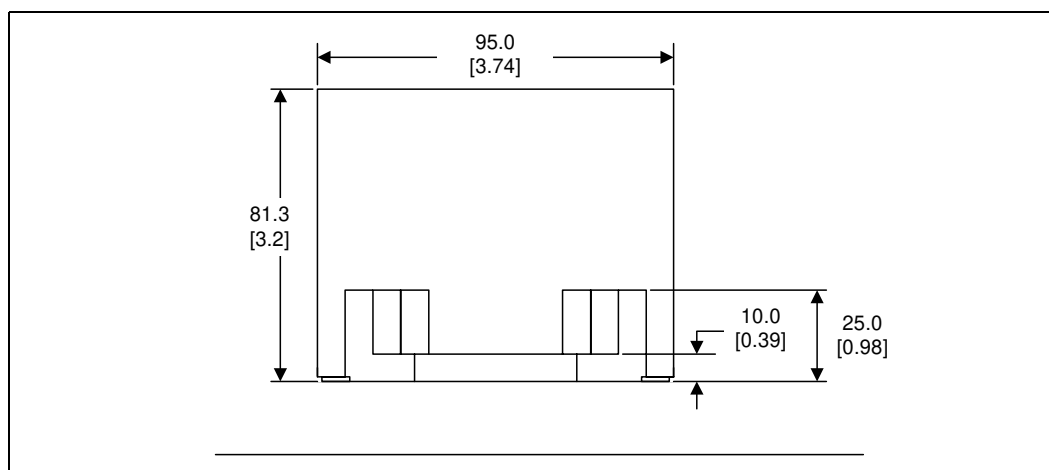
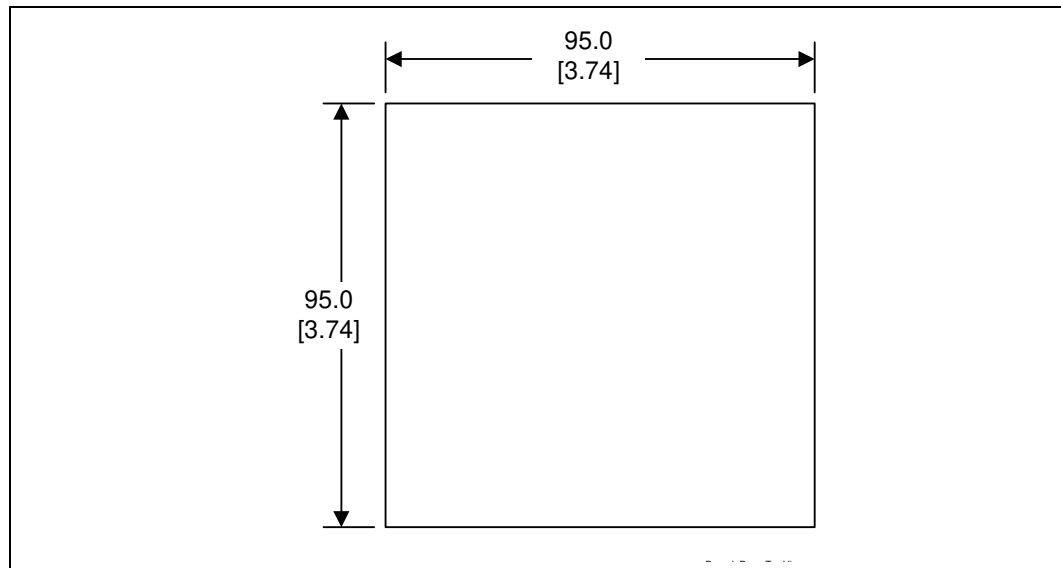

Figure 7-3. Space Requirements for the Boxed Processor (Top View)



**NOTES:**

1. Diagram does not show the attached hardware for the clip design and is provided only as a mechanical representation.

Figure 7-4. Space Requirements for the Boxed Processor (Overall View)

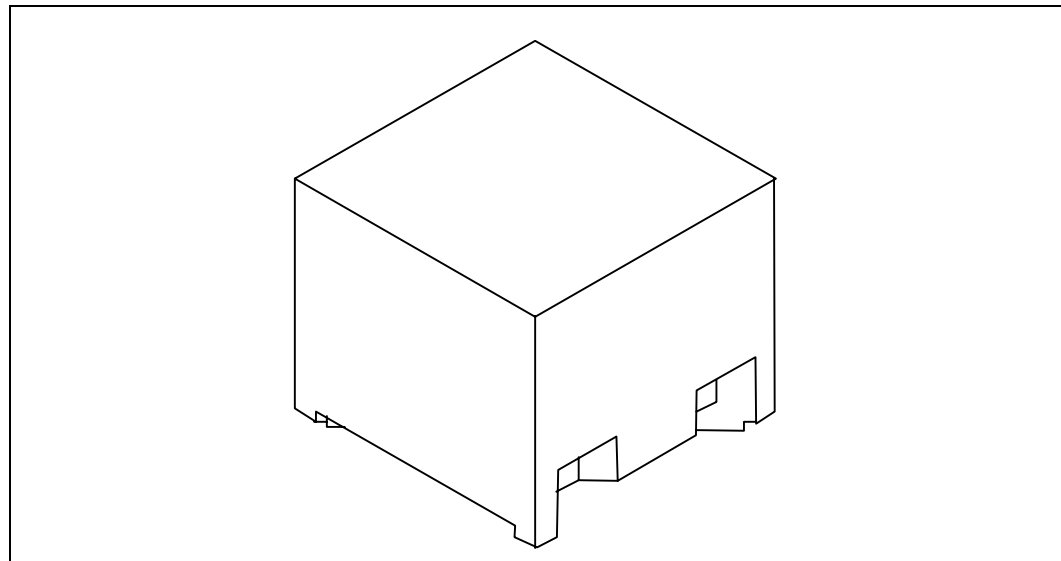

## 7.1.2 Boxed Processor Fan Heatsink Weight

The boxed processor fan heatsink will not weigh more than 450 grams. Refer to [Chapter 5](#) and the *Intel® Pentium® 4 Processor on 90 nm Process in the 775-Land LGA Package Thermal Design Guide* for details on the processor weight and heatsink requirements.

## 7.1.3 Boxed Processor Retention Mechanism and Heatsink Attach Clip Assembly

The boxed processor thermal solution requires a heatsink attach clip assembly to secure the processor and fan heatsink in the baseboard socket. The boxed processor will ship with the heatsink attach clip assembly.

## 7.2 Electrical Requirements

### 7.2.1 Fan Heatsink Power Supply

The boxed processor's fan heatsink requires a +12 V power supply. A fan power cable will be shipped with the boxed processor to draw power from a power header on the baseboard. The power cable connector and pinout are shown in [Figure 7-5](#). Baseboards must provide a matched power header to support the boxed processor. [Table 7-1](#) contains specifications for the input and output signals at the fan heatsink connector.

The fan heatsink outputs a SENSE signal that is an open-collector output that pulses at a rate of 2 pulses per fan revolution. A baseboard pull-up resistor provides  $V_{OH}$  to match the system board-mounted fan speed monitor requirements, if applicable. Use of the SENSE signal is optional. If the SENSE signal is not used, pin 3 of the connector should be tied to GND.

The fan heatsink receives a PWM signal from the motherboard from the 4<sup>th</sup> pin of the connector labeled as CONTROL.

**Note:** The boxed processor's fan heatsink requires a constant +12 V supplied to pin 2 and does not support variable voltage control or 3-pin PWM control.

The power header on the baseboard must be positioned to allow the fan heatsink power cable to reach it. The power header identification and location should be documented in the platform user's manual, or on the system board itself. [Figure 7-6](#) shows the location of the fan power connector relative to the processor socket. The baseboard power header should be positioned within 4.33 inches from the center of the processor socket.

Figure 7-5. Boxed Processor Fan Heatsink Power Cable Connector Description

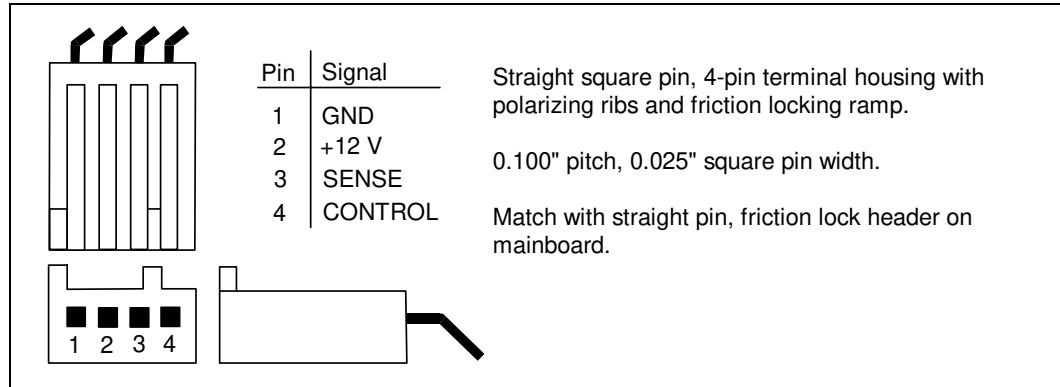

Table 7-1. Fan Heatsink Power and Signal Specifications

Description	Min	Typ	Max	Unit	Notes
+12V: 12 volt fan power supply	10.2	12	13.8	V	
IC:					
Peak Fan current draw	—	—	1.5	A	
Fan start-up current draw		1.1	2.2	A	
Fan start-up current draw maximum duration		—	1.0	Second	
SENSE: SENSE frequency	—	2	—	pulses per fan revolution	1
CONTROL	2100	2500	2800	Hz	2,3

**NOTES:**

1. Baseboard should pull this pin up to 5 V with a resistor.
2. Open Drain Type, Pulse Width Modulated.
3. Fan will have a pull-up resistor to 4.75 V (maximum 5.25 V).

Figure 7-6. Baseboard Power Header Placement Relative to Processor Socket

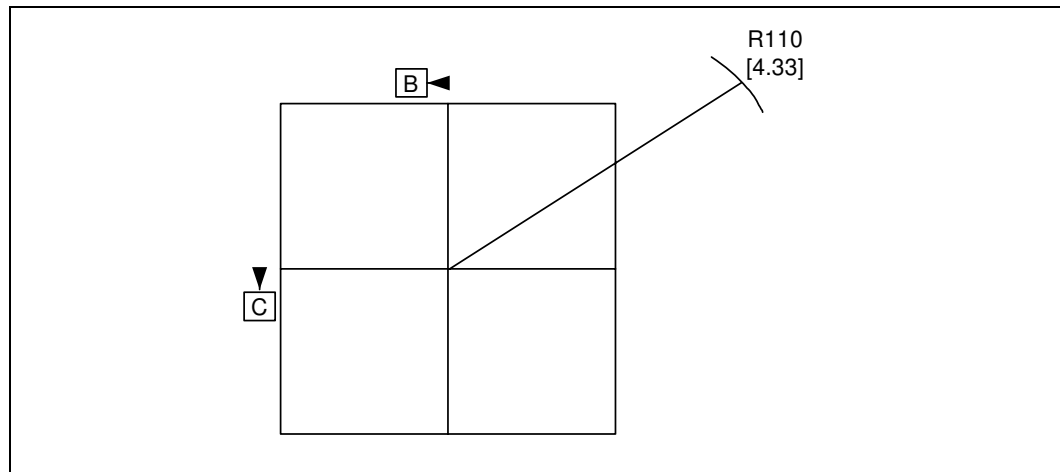

## 7.3 Thermal Specifications

This section describes the cooling requirements of the fan heatsink solution used by the boxed processor.

### 7.3.1 Boxed Processor Cooling Requirements

The boxed processor may be directly cooled with a fan heatsink. However, meeting the processor's temperature specification is also a function of the thermal design of the entire system, and ultimately the responsibility of the system integrator. For the processor temperature specification, refer to [Chapter 5](#). The boxed processor fan heatsink is able to keep the processor temperature within the specifications listed in [Table 5-1](#) for chassis that provide good thermal management. For the boxed processor fan heatsink to operate properly, it is critical that the airflow provided to the fan heatsink is unimpeded. Airflow of the fan heatsink is into the center and out of the sides of the fan heatsink. Airspace is required around the fan to ensure that the airflow through the fan heatsink is not blocked. Blocking the airflow to the fan heatsink reduces the cooling efficiency and decreases fan life. [Figure 7-7](#) and [Figure 7-8](#) illustrate an acceptable airspace clearance for the fan heatsink. The air temperature entering the fan should be kept below 38 °C. Again, meeting the processor's temperature specification is the responsibility of the system integrator.



Figure 7-7. Boxed Processor Fan Heatsink Airspace Keep-out Requirements (Top View)

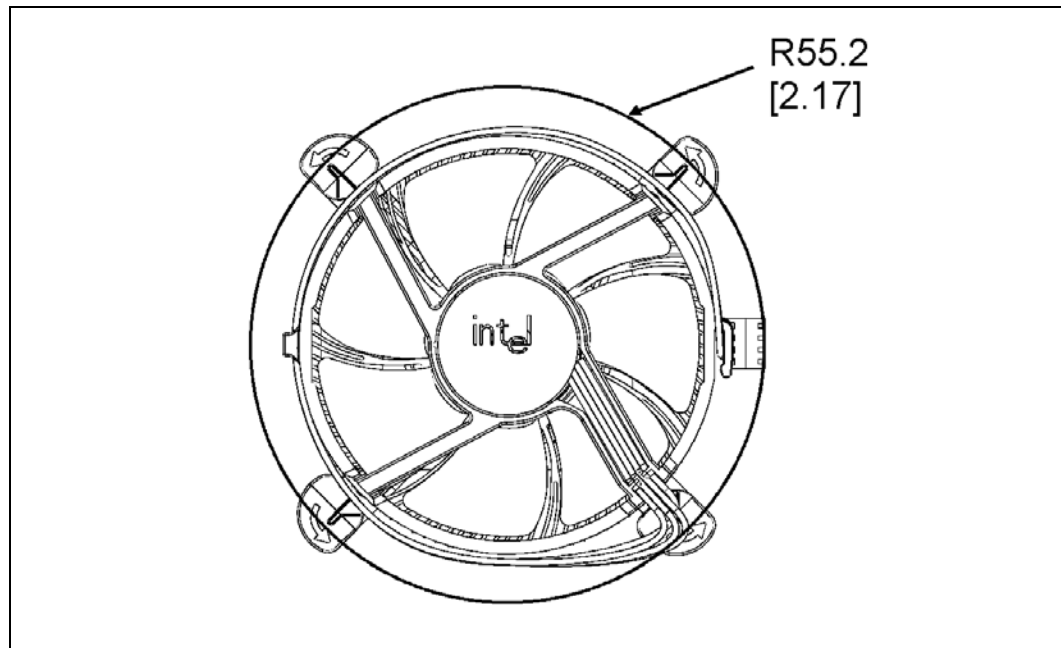
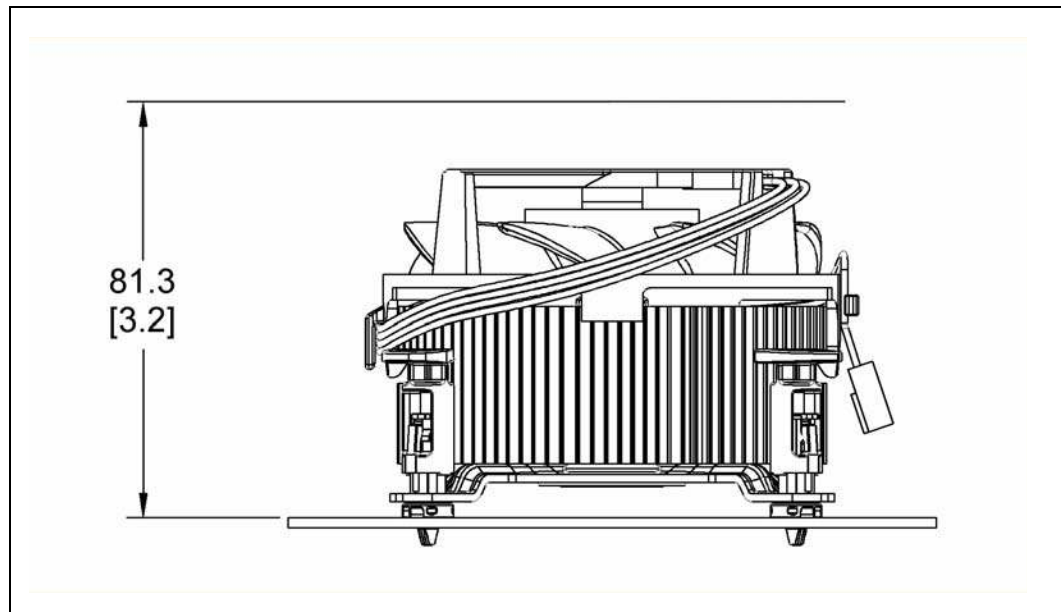

Figure 7-8. Boxed Processor Fan Heatsink Airspace Keep-out Requirements (Side View)



### 7.3.2 Variable Speed Fan

If the boxed processor fan heatsink 4-pin connector is connected to a 3-pin motherboard header, it will operate as follows:

The boxed processor fan will operate at different speeds over a short range of internal chassis temperatures. This allows the processor fan to operate at a lower speed and noise level, while internal chassis temperatures are low. If internal chassis temperature increases beyond a lower set point, the fan speed will rise linearly with the internal temperature until the higher set point is reached. At that point, the fan speed is at its maximum. As fan speed increases, so does fan noise levels. Systems should be designed to provide adequate air around the boxed processor fan heatsink that remains cooler than the lower set point. These set points, represented in [Figure 7-9](#) and [Table 7-2](#), can vary by a few degrees from fan heatsink to fan heatsink. The internal chassis temperature should be kept below 38 °C. Meeting the processor's temperature specification (see [Chapter 5](#)) is the responsibility of the system integrator.

**Note:** The motherboard must supply a constant +12 V to the processor's power header to ensure proper operation of the variable speed fan for the boxed processor (refer to [Table 7-1](#)) for the specific requirements.

**Figure 7-9. Boxed Processor Fan Heatsink Set Points**

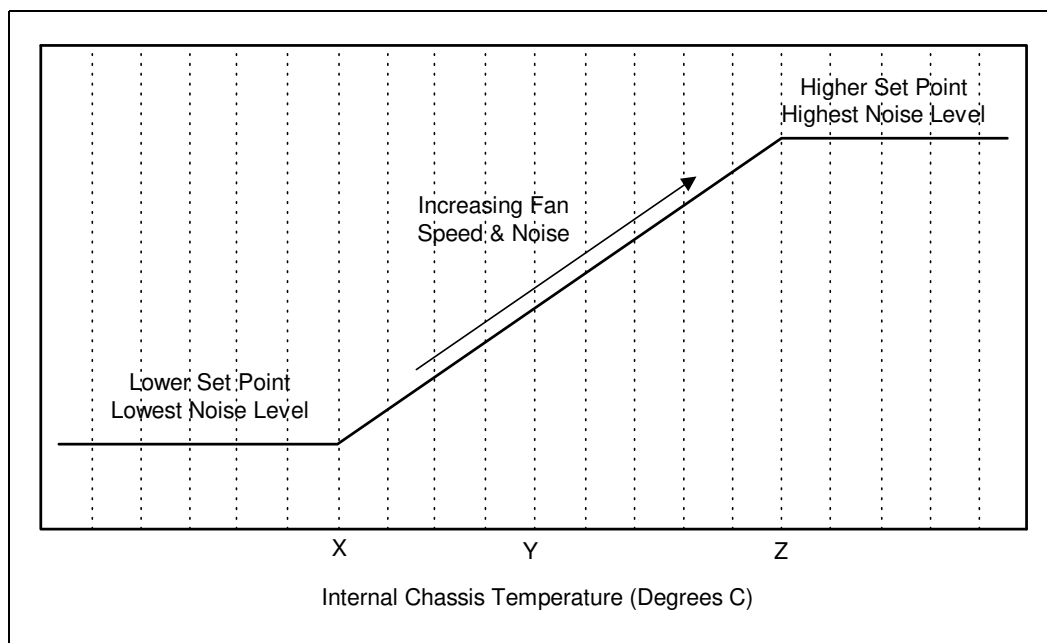

Table 7-2. Boxed Processor Fan Heatsink Set Points

Boxed Processor Fan Heatsink Set Point (°C)	Boxed Processor Fan Speed	Notes
X ≤ 30	When the internal chassis temperature is below or equal to this set point, the fan operates at its lowest speed. Recommended maximum internal chassis temperature for nominal operating environment.	1
Y = 34	When the internal chassis temperature is at this point, the fan operates between its lowest and highest speeds. Recommended maximum internal chassis temperature for worst-case operating environment.	
Z ≥ 38	When the internal chassis temperature is above or equal to this set point, the fan operates at its highest speed.	1

**NOTES:**

1. Set point variance is approximately ±1°C from fan heatsink to fan heatsink.

If the boxed processor fan heatsink 4-pin connector is connected to a 4-pin motherboard header and the motherboard is designed with a fan speed controller with PWM output (see CONTROL in Table 7-1) and remote thermal diode measurement capability, the boxed processor will operate as follows:

As processor power has increased the required thermal solutions have generated increasingly more noise. Intel has added an option to the boxed processor that allows system integrators to have a quieter system in the most common usage.

The 4<sup>th</sup> wire PWM solution provides better control over chassis acoustics. This is achieved by more accurate measurement of processor die temperature through the processor’s temperature diode (T<sub>DIODE</sub>). Fan RPM is modulated through the use of an ASIC located on the motherboard that sends out a PWM control signal to the 4<sup>th</sup> pin of the connector labeled as CONTROL. The fan speed is based on actual processor temperature instead of internal ambient chassis temperatures.

If the new 4-pin active fan heat sink solution is connected to an older 3-pin baseboard, processor fan header, it will default back to a thermistor controlled mode, allowing compatibility with existing 3-pin baseboard designs. Under thermistor controlled mode, the fan RPM is automatically varied based on the inlet temperature measured by a thermistor located at the fan inlet.

**Note:** For more details on specific motherboard requirements for 4-wire based fan speed control, see the *Intel® Pentium® 4 Processor on 90 nm Process in the 775-Land LGA Package Thermal Design Guide*.

§



# 8 Debug Tools Specifications

---

Refer to the *ITP700 Debug Port Design Guide* for information regarding debug tools specifications. The *ITP700 Debug Port Design Guide* is located on <http://developer.intel.com>.

## 8.1 Logic Analyzer Interface (LAI)

Intel is working with two logic analyzer vendors to provide logic analyzer interfaces (LAIs) for use in debugging Celeron D processor in the 775-land package systems. Tektronix\* and Agilent\* should be contacted to get specific information about their logic analyzer interfaces. The following information is general in nature. Specific information must be obtained from the logic analyzer vendor.

Due to the complexity of Celeron D processor in the 775-land package systems, the LAI is critical in providing the ability to probe and capture FSB signals. There are two sets of considerations to keep in mind when designing a Celeron D processor in the 775-land package system that can make use of an LAI: mechanical and electrical.

### 8.1.1 Mechanical Considerations

The LAI is installed between the processor socket and the Celeron D processor in the 775-land package. The LAI lands plug into the socket, while the Celeron D processor in the 775-land package lands plug into a socket on the LAI. Cabling that is part of the LAI egresses the system to allow an electrical connection between the Celeron D processor in the 775-land package and a logic analyzer. The maximum volume occupied by the LAI, known as the keep-out volume, as well as the cable egress restrictions, should be obtained from the logic analyzer vendor. System designers must make sure that the keep-out volume remains unobstructed inside the system. Note that it is possible that the keep-out volume reserved for the LAI may differ from the space normally occupied by the Celeron D processor in the 775-land package heatsink. If this is the case, the logic analyzer vendor will provide a cooling solution as part of the LAI.

### 8.1.2 Electrical Considerations

The LAI will also affect the electrical performance of the FSB; therefore, it is critical to obtain electrical load models from each of the logic analyzers to be able to run system level simulations to prove that their tool will work in the system. Contact the logic analyzer vendor for electrical specifications and load models for the LAI solution they provide.

§

