



2200 MHz Cavity Band Pass Filter



ANATECH ELECTRONICS INC
RF & Microwave Filters & Products

Part Number: AE2200B11704

Electrical Specifications

Center Frequency: 2200 MHz
Bandwidth(BW): 30 MHz
Passband Frequency (PB): 2185-2215 MHz
Insertion Loss : 1.0 dB Max
Return Loss : 15 dB Min.
Rejection1: 40 dB Min. @ 2125 MHz
Rejection2: 40 dB Min. @ 2270 MHz
Power Handling: 25 W Max.
Input / output Impedance: 50 Ohms

Mechanical

Mounting Method: Threaded Holes
Connector Type: SMA(F)
Dimensions: 4.125 x 1.5 x 1.0 in.

Environmental

Operating Temperature: -45°C to +75°C
Storage Temperature: -55°C to +85 °C
Shock: 20G. 11ms
Vibration: 20G 0.5 to 200 Hz

Outline Drawing:

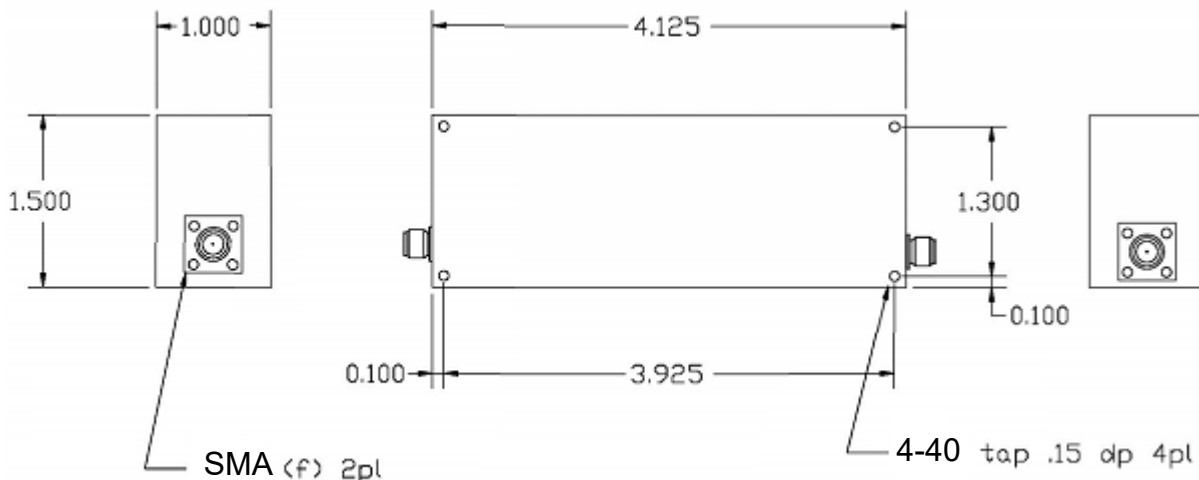

Tolerance: +/-0.01 inches [+/- 0.3mm]

Angles: +/- 1 Deg.

*Tolerance as shown unless otherwise specified in the datasheet electrical specification tables above.

*When max dimensions are called out the above tolerances do not apply as long as it is under the max call out.

70 Outwater Lane Phone: (973) 772-4242
Garfield, NJ 07026 Fax : (973) 321-3941

Email: sales@anatechelectronics.com
Web: www.anatechelectronics.com



ANATECH ELECTRONICS INC
RF & Microwave Filters & Products

2200 MHz Cavity Band Pass Filter

Part Number: AE2200B11704



Response Plot:

