

Customer Information Sheet

DRAWING No.: M60-604XX45

SHEET 2 OF 2

IF IN DOUBT - ASK

(C)

NOT TO SCALE

THIRD ANGLE PROJECTION

ALL DIMENSIONS IN mm

OBSOLETE

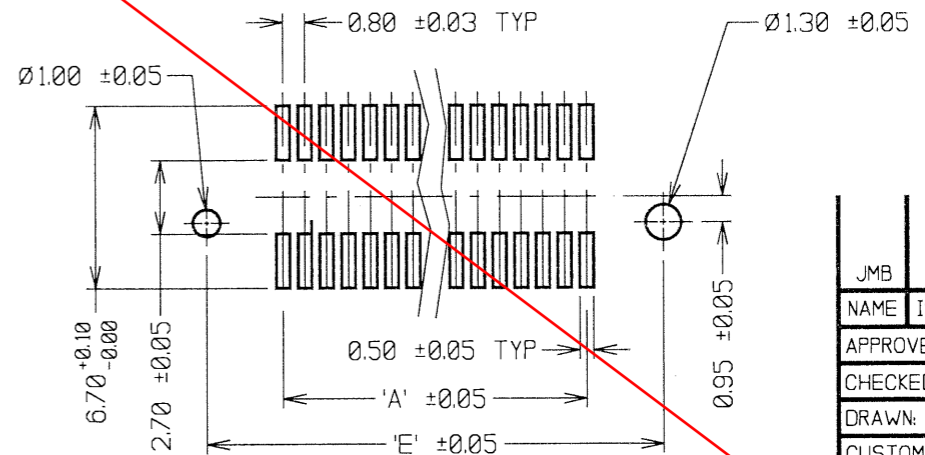
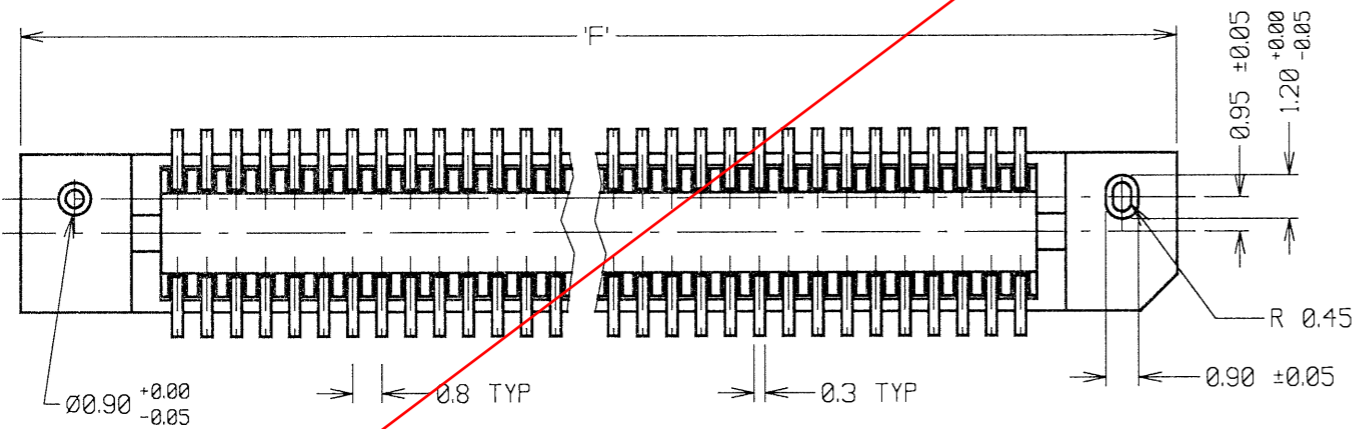
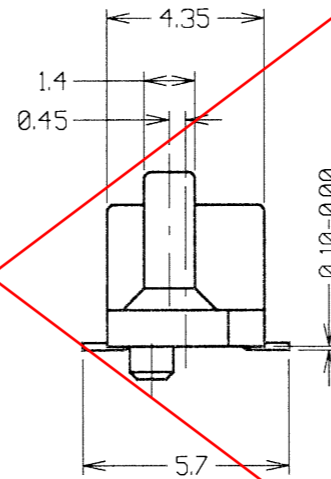
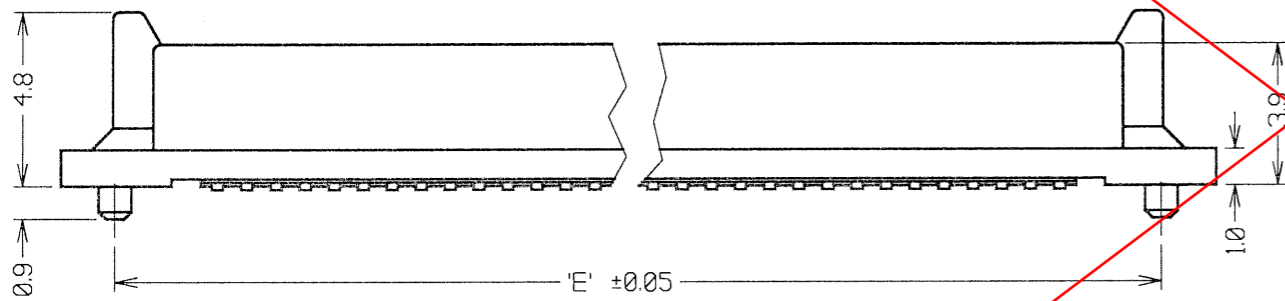
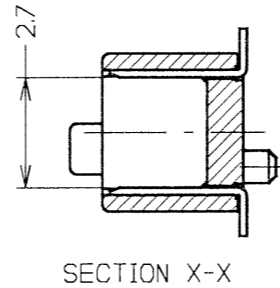
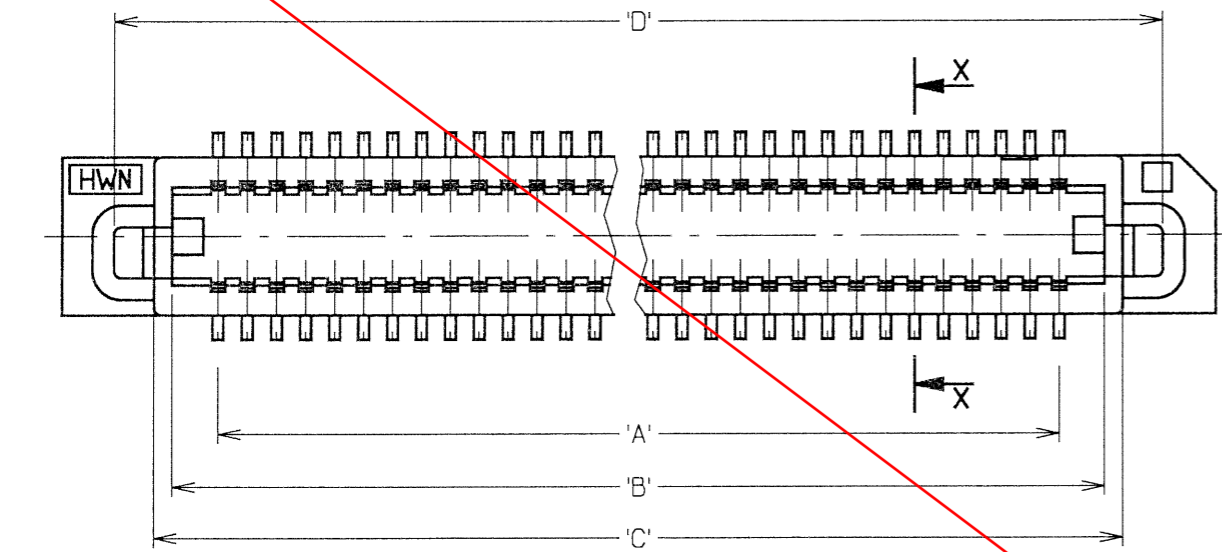

PART No.	No. OF CONTACTS	'A'	'B'	'C'	'D'	'E'	'F'
M60-6041045	10 + 10	7.2	9.7	10.7	12.9	12.8	15.8
M60-6041545	15 + 15	11.2	13.7	14.7	16.9	16.8	19.8
M60-6042045	20 + 20	15.2	17.7	18.7	20.9	20.8	23.8
M60-6042545	25 + 25	19.2	21.7	22.7	24.9	24.8	27.8
M60-6043045	30 + 30	23.2	25.7	26.7	28.9	28.8	31.8
M60-6044045	40 + 40	31.2	33.7	34.7	36.9	36.8	39.8
M60-6045045	50 + 50	39.2	41.7	42.7	44.9	44.8	47.8

SPECIFICATIONS:

MATERIAL:

MOULDING = LCP, UL94V-0
CONTACTS = PHOSPHOR BRONZE

FINISH:

CONTACTS:
0.05µ MIN GOLD OVER 1.27µ MIN NICKEL
0.5µ MIN GOLD ON CONTACT AREA.

ELECTRICAL:

CURRENT RATING = 0.5 AMPS
VOLTAGE RATING = 100V AC
DIELECTRIC WITHSTANDING VOLTAGE = 300V AC (1 MINUTE)
INSULATION RESISTANCE = 1000 MEGOHMS MIN (250V DC)
CONTACT RESISTANCE = 40 MILLIOHMS MAX

MECHANICAL:

DURABILITY = 30 CYCLES

ENVIRONMENTAL:

TEMPERATURE RANGE = -55°C TO +100°C
PACKING = TUBE

NOTES.

- MATES WITH M60-614XX45 OR M60-616XX45 TO GIVE BOARD-TO-BOARD HEIGHTS OF 5mm AND 7mm RESPECTIVELY.
- ALL TOLERANCES ±0.30 UNLESS OTHERWISE STATED.

ORDER CODE:

M60-604XX45

No. OF CONTACTS

10, 15, 20, 25, 30, 40, 50

HARWIN

HARWIN USA
TEL: 603 893 5376
FAX: 603 893 5396
mis@harwin.com

HARWIN Europe (UK)
TEL: 023 9231 4545
FAX: 023 9231 4590
mis@harwin.co.uk

HARWIN Asia
TEL: +65 6 779 4909
FAX: +65 6 779 3868
mis@harwin.com.sg

THIS DRAWING AND ANY INFORMATION OR DESCRIPTIVE MATTER SET OUT HEREON ARE CONFIDENTIAL AND COPYRIGHT PROPERTY OF THE HARWIN GROUP AND MUST NOT BE DISCLOSED, LOANED, COPIED OR USED FOR MANUFACTURING, TENDERING OR FOR ANY OTHER PURPOSE WITHOUT THEIR WRITTEN PERMISSION.

TOLERANCES
X. = ±1mm
X.X = ±0.25mm
X.XX = ±0.10mm
X.XXX = ±0.01mm
ANGLES = ±5°
UNLESS STATED

MATERIAL:
SEE ABOVE
FINISH: SEE ABOVE
S/AREA: mm²

TITLE:
0.80mm PITCH SMT SOCKET CONNECTOR (4mm HIGH)

DRAWING NUMBER:

M60-604XX45

SHT 2 OF 2

JMB	9	17.07.06	9324
NAME	ISS.	DATE	C/NOTE
APPROVED: <i>[Signature]</i>			
CHECKED: <i>[Signature]</i>			
DRAWN: WJ BOURNE			
CUSTOMER REF.:			
ASSEMBLY DRG:			