

LT3952AEFE
60V LED Driver
with Internal 4A Switch

DESCRIPTION

Demonstration Circuit DC2013A is a 60V LED driver with internal 4A switch featuring the [LT[®]3952A](#) monolithic LED driver. It accepts an input voltage from 5V to 36V (with transient to 42V) and boosts to a single string of LEDs up to 50V LEDs at 330mA. DC2013A features an integrated 4A switch, constant-current and constant-voltage output control as well as input current limit and monitoring.

The LT3952A has a wide input voltage range down to 3V and up to 42V. It has adjustable switching frequency between 200kHz and 3MHz. It has an option for external frequency synchronization or spread spectrum frequency modulation. It has high PWM dimming capability from an external signal and can be PWM dimmed with an internally generated PWM oscillator and analog input signal. It can be analog dimmed with a control voltage on its control pin. LT3952A features both Open-LED and Short-LED (LED+ to GND) protection as well as fault output flags for each. Although DC2013A is assembled as a boost LED driver, it can be altered to be run as a buck mode, buck-boost mode or boost-buck LED driver.

DC2013A features an option to turn on spread spectrum by simply changing the position of a jumper from NO SPREAD to SPREAD or to EXTERNAL SYNC.

Small ceramic input and output capacitors are used to save space and cost. The Open-LED overvoltage protection uses the IC's constant-voltage regulation loop to regulate the output to approximately 55V if the LED string is

opened although it may reach 59V peak during transient from running LEDs to open. There is a protection diode from LED+ to GND to prevent negative ringing during a short-circuit with long wires.

There is undervoltage and overvoltage lockout that can be adjusted on the circuit with a few simple resistor choices.

There is an EMI filter on the input of DC2013A. This EMI filter has both an LC stage to reduce EMI below 20MHz and a ferrite bead to reduce higher frequency EMI. The PCB layout contains a small hot-loop for minimized high frequency EMI. The EMI filter can be used by connecting to the "EMI V_{IN}" terminal. However, if the EMI filter is not needed, the input connection can be directly to the PV_{IN} terminal. If the EMI filter is not used, it is recommended to remove the EMI filter if EMI measurements are being made from the PV_{IN} terminal for base EMI testing. It can be replaced for EMI testing at the EMI V_{IN} terminal.

The LT3952A data sheet gives a complete description of the part, operation and applications information. The data sheet must be read in conjunction with this Demo Manual for Demonstration Circuit 2013A. The LT3952AEFE is assembled in a 28-lead plastic TSSOP (FE) package with a thermally enhanced ground pad. Proper board layout is essential for maximum thermal performance. See the data sheet section "Layout Considerations".

[Design files for this circuit board are available.](#)

All registered trademarks and trademarks are the property of their respective owners.

PERFORMANCE SUMMARY

PARAMETER	CONDITION	MIN	TYP	MAX	UNITS
Input Voltage PV_{IN} and EMI V_{IN} Range	Operating $V_{IN} = PV_{IN}$ $V_{LED} > 36V$	5		36	V
Switching Frequency	$R2 = 287k$		350		kHz
I_{LED}	$R1 = 0.75\Omega$ $7.0V < PV_{IN} < 36V$ $V_{LED} > 36V$		333		mA
Low PV_{IN} I_{LED} (CTRL Foldback)	$R1 = 0.75\Omega$ $PV_{IN} = 5.0V$ $R1 = 0.75\Omega$ $PV_{IN} = 6.0V$		270 320		mA mA
V_{LED} Range	$R4 = 1M$, $R5 = 22.6k$	PV_{IN}		50	V
Open-LED Voltage V_{OUT}	$R4 = 1M$, $R5 = 22.6k$		54.3		V
Typical Efficiency (100% PWM DC)	$PV_{IN} = 14V$ $V_{LED} = 50V$ $I_{LED} = 333mA$		92.2		%
Input Undervoltage Lockout (Falling Turn-Off)	$R7 = 499k$, $R8 = 196k$, $R9 = 24.3k$		4.1		V
Input Undervoltage Lockout (Rising Turn-On)	$R7 = 499k$, $R8 = 196k$, $R9 = 24.3k$		5.4		V
V_{ISMON}	Operating $I_{LED} = 330mA$		1.0		V
Peak Switch Current Limit	Operating		4		A

QUICK START PROCEDURE

Demonstration Circuit 2013A is easy to set up to evaluate the performance of the LT3952A. Follow the procedure below:

1. Connect a string of LEDs that will run with forward voltage less than or equal to 50V (at 330mA), but greater than PV_{IN} , to the LED+ and GND terminals on the PCB as shown in Figure 1.
2. Connect the EN/UVLO terminal to GND.
3. With power off, connect the input power supply to the EMI V_{IN} (or PV_{IN}) and GND terminals. Make sure that the DC input voltage will not exceed 42V (or V_{LED}).
4. Turn the input power supply on and make sure the voltage is between 5V and 36V (or V_{LED}) for proper operation.
5. Release the EN/UVLO-to-GND connection.
6. Observe the LED strings running at the programmed LED current.
7. To change the brightness with analog dimming, simply attach a voltage source to the CTRL terminal and set the voltage between 0V and 1.5V. See data sheet for details.
8. To change brightness with external PWM dimming, attach a 3V rectangular waveform with varying duty cycle to the PWM terminal.
9. To enable spread spectrum frequency modulation, simply change the position of the shunt on the SYNC/SPRD jumper to the SPREAD SPECTRUM position.

DEMO CIRCUIT OPTIONS

Demonstration Circuit 2013A can be adjusted for higher or lower output voltage, different LED current, or different topology. The following options are for simple changes to the demonstration circuit. The data sheet gives more information regarding designing with the LT3952A. For more information, see the data sheet for details or contact Linear Tech customer support. For buck mode, V_{IN} and PV_{IN} must be separated by a trace cut on layer one. However, there is also a connection between PV_{IN} and V_{IN} on layer 3. Please see the layer files and make a drill hole to separate PV_{IN} and V_{IN} entirely for buck mode.

MAXIMUM LED VOLTAGE

DC2013A is set for 54.3V of overvoltage protection and the maximum LED string voltage used on the standard build should be 50V. Some margin is provided to limit the Open-LED overshoot above 55V in order to stay safely below the 60V limit. See data sheet for details.

CURRENT OR VOLTAGE REGULATION

The LT3952A can be used for constant-current or voltage regulation. If the load placed on the LED+ to GND terminals allows V_{OUT} to climb high enough for $V_{(ISP-ISN)} = 1.2V$, then the voltage regulation loop of the converter takes over. In this case, the compensation for a given

QUICK START PROCEDURE

channel should be adjusted for proper use as a constant-voltage regulator. The IC can be used as a boost or SEPIC constant-voltage regulator. Output voltage should remain below 60V when used as a constant-voltage device.

LED CURRENT

LED current on DC2013A is set for 330mA with 0.75Ω resistor R1. For a different maximum LED current, change this resistor. $250\text{mV}/R_{\text{LED}} = I_{\text{LED}}$.

A change in LED current or input voltage may lead to higher or lower maximum switch current. The maximum switch current for this converter is 4A and is fixed internally.

OVERVOLTAGE PROTECTION

Overvoltage protection is set with the resistor pair R4 and R5 for the boost topology. For buck mode, buck-boost mode, and boost-buck see data sheet for details how to set the feedback resistors. Note that R19, R20, R21, and Q1 are provided as optional placeholders on the demonstration circuit for simple feedback resistor changes for these topologies.

UNDERVOLTAGE AND OVERVOLTAGE LOCKOUT

UVLO and OVLO can be adjusted by changing the values of R7, R8 and R9.

Resistors R13, R14, and R15 are available for setting UVLO and OVLO separately or for referring them to OUT for other topologies.

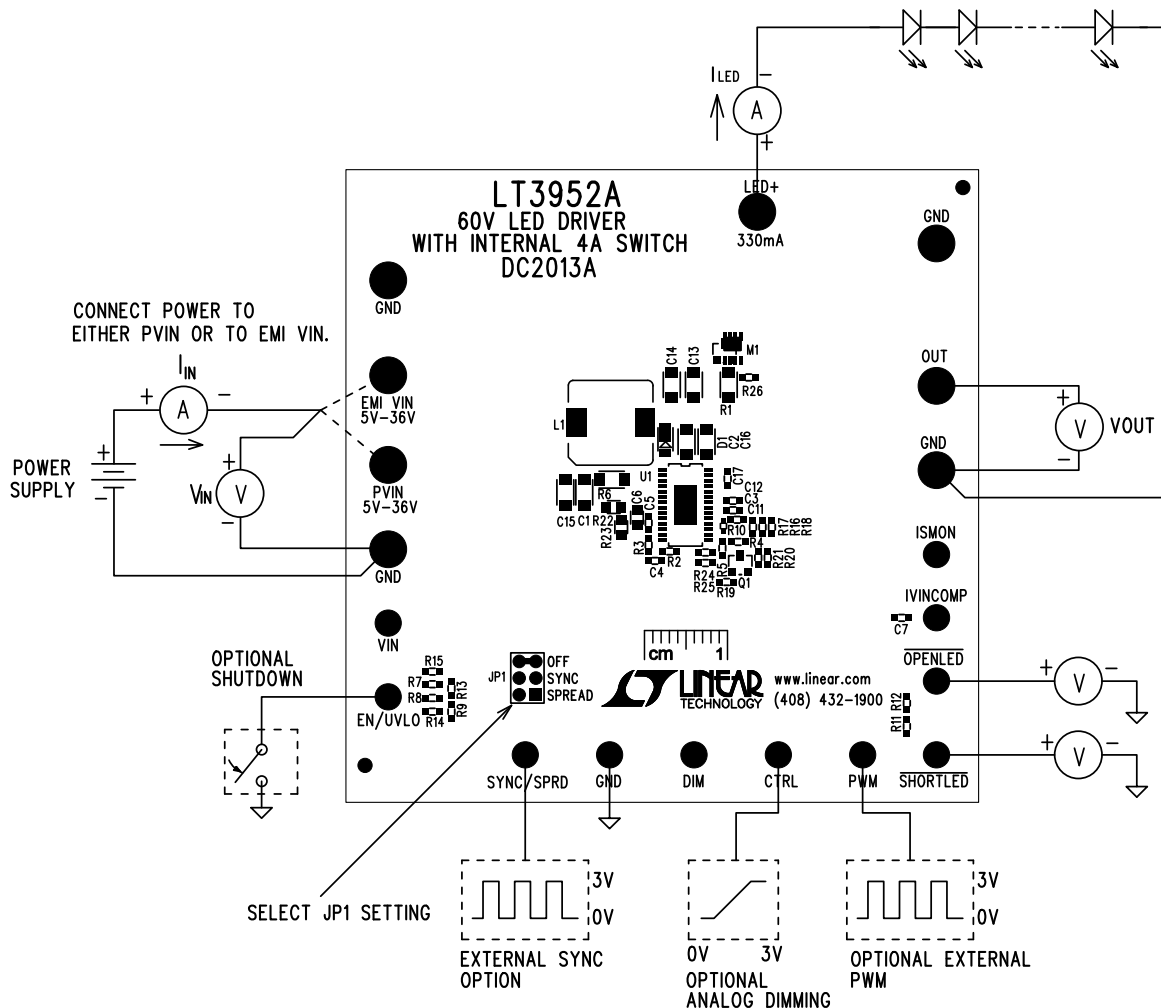

Figure 1. Test Procedure Setup Drawing for DC2013A

QUICK START PROCEDURE

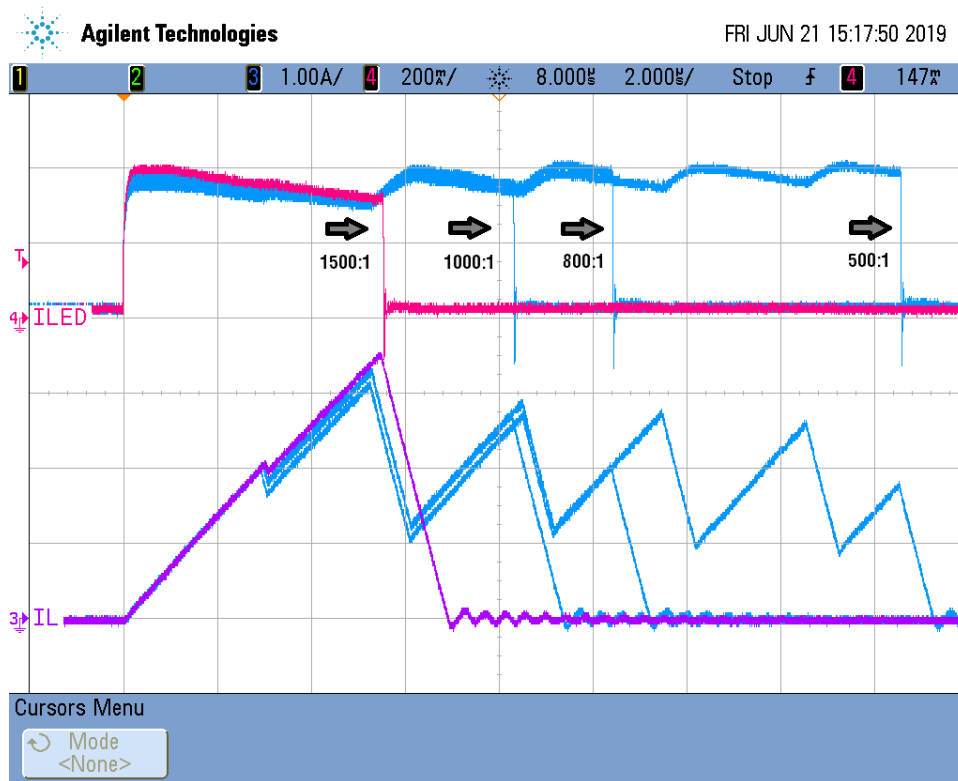

Figure 2. DC2013A 12V_{IN} 120Hz PWM Dimming Waveforms at Different PWM Duty Cycles with 1500:1 in Bold. I_{LED} Waveform (200mA/DIV) Is on Top (with 50V LED String) and I_{L1} Waveform (1A/DIV) Is on the Bottom

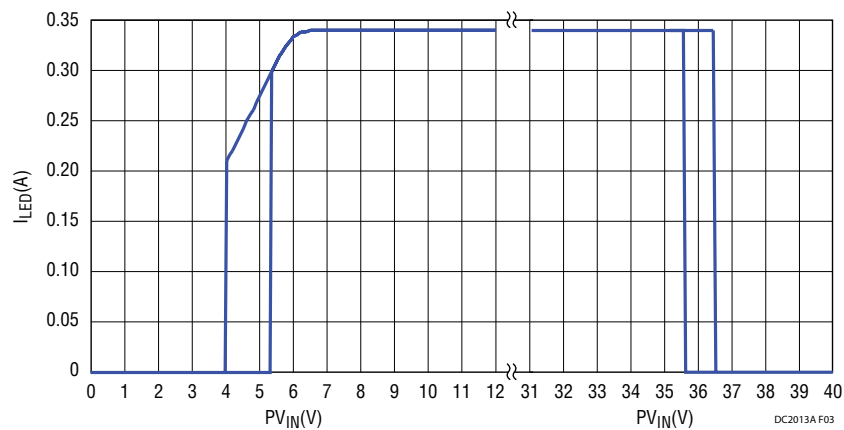
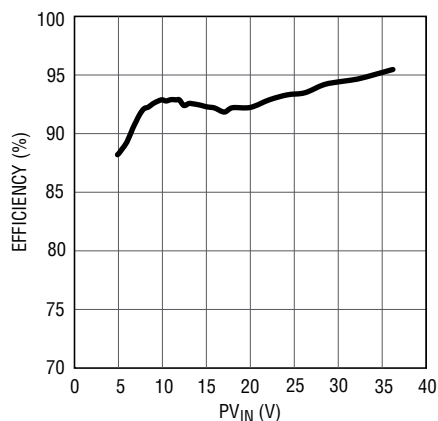

Figure 3. DC2013A CTRL LED Current Foldback at Low Input with UVLO and OVLO Falling and Rising

QUICK START PROCEDURE



DC2013A F04

Figure 4. DC2013A Efficiency at Maximum I_{LED} vs PV_{IN} with 50V LEDs (at 330mA)

PARTS LIST

ITEM	QTY	REFERENCE	PART DESCRIPTION	MANUFACTURER/PART #
Required Electrical Components				
1	1	C1	CAP., X5R, 10μF, 50V, 10% 1206	MURATA, GRM31CR61H106KA12L
2	1	C2	CAP., X7S, 4.7μF, 100V, 10% 1206	AVX, 12061Z475KAT2A
3	1	C3	CAP., X7R, 0.22μF, 10V, 10% 0603	MURATA, GRM188R71A224KA01J
4	1	C4	CAP., X7R, 4.7nF, 10V, 10% 0603	AVX, 0603ZC472KAT2A
5	1	C5	CAP., X5R, 2.2μF, 6.3V, 10% 0603	AVX, 06036D225KAT2A
6	1	C6	CAP., X7R, 1μF, 50V, 10% 0805	MURATA, GRM21BR71H105KA12L
7	1	D1	SCHOTTKY RECTIFIER	DIODES INC., DFLS260-7
8	1	L1	INDUCTOR, 15μH	WÜRTH ELEKTRONIK, 7447798151
9	1	M1	P-MOSFET, SI2307CDS, SOT23	VISHAY, SI2307CDS-T1-GE3
10	1	R1	RES., CHIP, 0.75Ω, 0.5W, 1% 1206	SUSUMU, RL1632R-R750-F
11	1	R2	RES., CHIP, 287k, 1/10W, 1% 0603	VISHAY, CRCW0603287KFKEA
12	1	R3	RES., CHIP, 3.0k, 1/10W, 5% 0603	VISHAY, CRCW06033K00JNEA
13	1	R4	RES., CHIP, 1M, 1/10W, 1% 0603	VISHAY, CRCW06031M00FKEA
14	1	R5	RES., CHIP, 22.6k, 1/10W, 1% 0603	VISHAY, CRCW060322K6FKEA
15	1	R6	RES., CHIP, 0.015Ω, 1W, 1% 1206	PANASONIC, ERJ-8BWFR015V
16	1	U1	I.C., LED DRIVER, TSSOP-28	LINEAR TECH., LT3952AEFE#PBF

DEMO MANUAL DC2013A

PARTS LIST

ITEM	QTY	REFERENCE	PART DESCRIPTION	MANUFACTURER/PART #
Optional Electrical Components				
1	1	C7	CAP., X7R, 0.47 μ F, 25V, 10% 0603	MURATA, GRM188R71E474KA12D
2	1	C8	CAP., ALUM., 33 μ F, 50V, 6.3 \times 7.7	PANASONIC, EEHZA1H330XP
3	1	C9	CAP., X5R, 2.2 μ F, 50V, 10% 1206	MURATA, GRM31CR71H225KA88L
4	1	C10	CAP., X5R, 0.1 μ F, 50V, 10% 0402	MURATA, GRM155R61H104KE14J
5	0	C11, C12, C17 (OPT)	CAP., 0603	
6	0	C13, C14 (OPT)	CAP., 1206	
7	0	C15, C16 (OPT)	CAP., 1206	
8	0	C18 (OPT)	CAP., 0805	MURATA, GRM21BR71H105KA12L
9	1	D2	RECTIFIER, SMA	DIODES INC., ES1B-13-F
10	1	FB1	BEAD, CHIP, 100 Ω , 0805	TDK, MPZ2012S101AT000
11	1	L2	INDUCTOR, 4.7 μ H	VISHAY, IHLP2020CZER4R7M11
12	0	Q1 (OPT)	PNP SOT23	
13	1	R7	RES., CHIP, 499k, 1/10W, 1% 0603	VISHAY, CRCW0603499KFKEA
14	1	R8	RES., CHIP, 196k, 1/10W, 1% 0603	VISHAY, CRCW0603196KFKEA
15	1	R9	RES., CHIP, 24.3k, 1/10W, 1% 0603	VISHAY, CRCW060324K3FKEA
16	0	R10 (OPT)	RES., 0402	
17	2	R11, R12	RES., CHIP, 100k, 1/10W, 1% 0603	VISHAY, CRCW0603100KFKEA
18	0	R13-R15, R18-R21, R24-R26 (OPT)	RES., 0603	
19	1	R16	RES., CHIP, 1M, 1/10W, 1% 0603	VISHAY, CRCW06031M00FKEA
20	1	R17	RES., CHIP, 249k, 1/10W, 1% 0603	VISHAY, CRCW0603249KFKEA
21	0	R22, R23 (OPT)	RES., 0805	
Hardware				
1	8	E1-E8	TESTPOINT, TURRET, 0.094" PBF	MILL-MAX, 2501-2-00-80-00-00-07-0
2	11	E9-E19	TESTPOINT, TURRET, 0.061" PBF	MILL-MAX, 2308-2-00-80-00-00-07-0
3	1	JP1	HEADER 3-PIN 0.079" DOUBLE ROW	WÜRTH ELEKTRONIK, 620 006 211 21
4	1	XJP1	SHUNT, 0.079" CENTER	WÜRTH ELEKTRONIK, 608 002 134 21

SCHEMATIC DIAGRAM

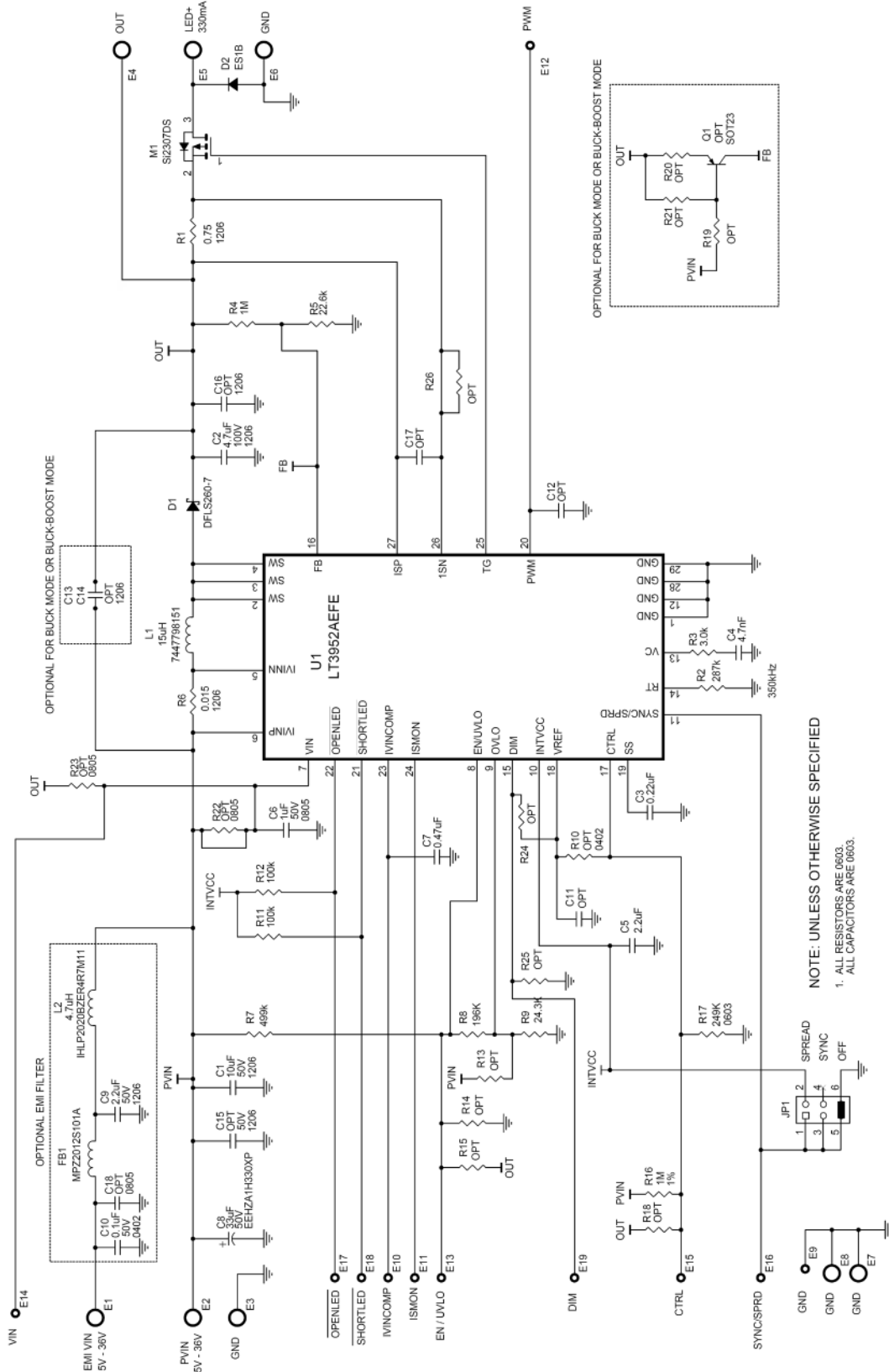



ESD Caution

ESD (electrostatic discharge) sensitive device. Charged devices and circuit boards can discharge without detection. Although this product features patented or proprietary protection circuitry, damage may occur on devices subjected to high energy ESD. Therefore, proper ESD precautions should be taken to avoid performance degradation or loss of functionality.

Legal Terms and Conditions

By using the evaluation board discussed herein (together with any tools, components documentation or support materials, the "Evaluation Board"), you are agreeing to be bound by the terms and conditions set forth below ("Agreement") unless you have purchased the Evaluation Board, in which case the Analog Devices Standard Terms and Conditions of Sale shall govern. Do not use the Evaluation Board until you have read and agreed to the Agreement. Your use of the Evaluation Board shall signify your acceptance of the Agreement. This Agreement is made by and between you ("Customer") and Analog Devices, Inc. ("ADI"), with its principal place of business at One Technology Way, Norwood, MA 02062, USA. Subject to the terms and conditions of the Agreement, ADI hereby grants to Customer a free, limited, personal, temporary, non-exclusive, non-sublicensable, non-transferable license to use the Evaluation Board FOR EVALUATION PURPOSES ONLY. Customer understands and agrees that the Evaluation Board is provided for the sole and exclusive purpose referenced above, and agrees not to use the Evaluation Board for any other purpose. Furthermore, the license granted is expressly made subject to the following additional limitations: Customer shall not (i) rent, lease, display, sell, transfer, assign, sublicense, or distribute the Evaluation Board; and (ii) permit any Third Party to access the Evaluation Board. As used herein, the term "Third Party" includes any entity other than ADI, Customer, their employees, affiliates and in-house consultants. The Evaluation Board is NOT sold to Customer; all rights not expressly granted herein, including ownership of the Evaluation Board, are reserved by ADI. CONFIDENTIALITY. This Agreement and the Evaluation Board shall all be considered the confidential and proprietary information of ADI. Customer may not disclose or transfer any portion of the Evaluation Board to any other party for any reason. Upon discontinuation of use of the Evaluation Board or termination of this Agreement, Customer agrees to promptly return the Evaluation Board to ADI. ADDITIONAL RESTRICTIONS. Customer may not disassemble, decompile or reverse engineer chips on the Evaluation Board. Customer shall inform ADI of any occurred damages or any modifications or alterations it makes to the Evaluation Board, including but not limited to soldering or any other activity that affects the material content of the Evaluation Board. Modifications to the Evaluation Board must comply with applicable law, including but not limited to the RoHS Directive. TERMINATION. ADI may terminate this Agreement at any time upon giving written notice to Customer. Customer agrees to return to ADI the Evaluation Board at that time. LIMITATION OF LIABILITY. THE EVALUATION BOARD PROVIDED HEREUNDER IS PROVIDED "AS IS" AND ADI MAKES NO WARRANTIES OR REPRESENTATIONS OF ANY KIND WITH RESPECT TO IT. ADI SPECIFICALLY DISCLAIMS ANY REPRESENTATIONS, ENDORSEMENTS, GUARANTEES, OR WARRANTIES, EXPRESS OR IMPLIED, RELATED TO THE EVALUATION BOARD INCLUDING, BUT NOT LIMITED TO, THE IMPLIED WARRANTY OF MERCHANTABILITY, TITLE, FITNESS FOR A PARTICULAR PURPOSE OR NON-INFRINGEMENT OF INTELLECTUAL PROPERTY RIGHTS. IN NO EVENT WILL ADI AND ITS LICENSORS BE LIABLE FOR ANY INCIDENTAL, SPECIAL, INDIRECT, OR CONSEQUENTIAL DAMAGES RESULTING FROM CUSTOMER'S POSSESSION OR USE OF THE EVALUATION BOARD, INCLUDING BUT NOT LIMITED TO LOST PROFITS, DELAY COSTS, LABOR COSTS OR LOSS OF GOODWILL. ADI'S TOTAL LIABILITY FROM ANY AND ALL CAUSES SHALL BE LIMITED TO THE AMOUNT OF ONE HUNDRED US DOLLARS (\$100.00). EXPORT. Customer agrees that it will not directly or indirectly export the Evaluation Board to another country, and that it will comply with all applicable United States federal laws and regulations relating to exports. GOVERNING LAW. This Agreement shall be governed by and construed in accordance with the substantive laws of the Commonwealth of Massachusetts (excluding conflict of law rules). Any legal action regarding this Agreement will be heard in the state or federal courts having jurisdiction in Suffolk County, Massachusetts, and Customer hereby submits to the personal jurisdiction and venue of such courts. The United Nations Convention on Contracts for the International Sale of Goods shall not apply to this Agreement and is expressly disclaimed.