

# JTAG-Booster for AMD ÉlanSC520



P.O. Box 1103  
Kueferstrasse 8  
☎ +49 (7667) 908-0  
sales@fsforth.de

- D-79200 Breisach, Germany
- D-79206 Breisach, Germany
- Fax +49 (7667) 908-200
- <http://www.fsforth.de>

Copyright © 1995..2002:

FS FORTH-SYSTEME GmbH  
Postfach 1103, D-79200 Breisach, Germany

Release of Document:      March 12, 2002  
Author:                      Dieter Fögele  
Filename:                     JTAGEL5d.doc  
Program Version:            3.xx

All rights reserved. No part of this document may be copied or reproduced in any form or by any means without the prior written consent of FS FORTH-SYSTEME GmbH.

---

**Table of Contents**

1. General.....	4
1.1. System Requirements .....	4
1.2. Connecting your PC to the target system.....	5
1.3. First Example .....	7
1.4. Trouble Shooting .....	9
1.5. Error Messages.....	10
1.6. Initialization file JTAGEL5.INI .....	14
1.7. Supported flash devices.....	22
2. JTAGEL5 Parameter Description.....	27
2.1. Programming a Flash Device.....	30
2.2. Read a Flash Device to file .....	34
2.3. Verify a Flash Device with file .....	36
2.4. Dump target memory.....	38
2.5. Program an I <sup>2</sup> C-Device.....	39
2.6. Read an I <sup>2</sup> C-Device to file .....	41
2.7. Verify an I <sup>2</sup> C-Device with file .....	43
2.8. Dump an I <sup>2</sup> C-Device .....	45
2.9. Toggle CPU pins .....	46
2.10. Polling CPU pins .....	47
2.11. Polling CPU pins while the CPU is running .....	48
2.12. List of supported Flash Devices .....	49
3. Implementation Information .....	50

## **1. General**

The program JTAGEL5 uses the JTAG port of the AMD ÉlanSC520 embedded microprocessor in conjunction with the small JTAG-BOOSTER:

- to program data into flash memory
- to verify and read the contents of a flash memory
- to make a memory dump
- to access a I2C Device
- to test CPU signals

All functions are done without any piece of software running in the target. No firmware or BIOS must be written. Bootstrap software may be downloaded to initially unprogrammed memories.

For latest documentation please refer to the file README.TXT on the distribution disk.

### **1.1.System Requirements**

To successfully run this tool the following requirements must be met:

- MSDOS, WIN3.x, WIN9x or WinNT  
(WinNT is supported with an additional support-kit)
- Intel 80386 or higher
- 205 kByte of free DOS memory
- no extended memory
- Parallel Port

## 1.2.Connecting your PC to the target system

The JTAG-Booster can be plugged into standard parallel ports (LPT1-3) with a DB25-Connector.

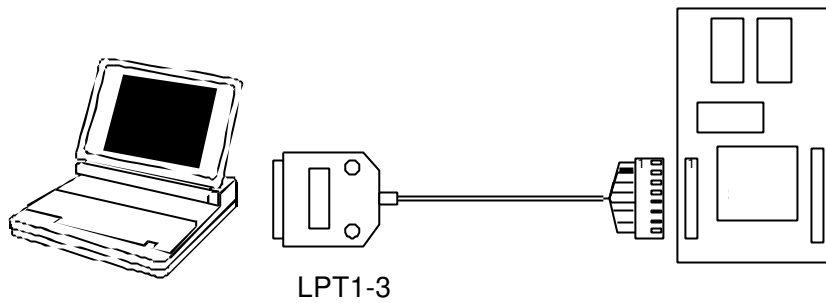

The target end of the cable has the following reference:

1	2*	3	4	5	6	7	8
TCK	GND	TMS	TRST#	NC	TDI	TDO	+3.3V

\*PIN 2 can be detected by the white thick cable.

To connect your design to the JTAG-BOOSTER you need a single row berg connector with a spacing of 2.54mm on your PCB. The names refer to the target: Pin 7 is the target's TDO pin and is connected to the JTAG-Booster's TDI pin.

**A 3.3V version of the JTAG-Booster is delivered for the AMD ElanSC520. Do not connect the 3.3V JTAG-Booster to a 5V power supply. The JTAG-Booster may be damaged.**

Before you start the program, the JTAG-BOOSTER must be plugged to a parallel interface of your PC and to the 8 pin JTAG connector on the target.

The utility is started with the general command line format:

JTAGEL5 /function [filename] [/option\_1] ... [/option\_n].

Note that the function must be the first argument followed (if needed) by the filename.

If you want to cancel execution of JTAGEL5, press CTRL-Break-Key.

On any error the program aborts with an MSDOS error level of one.

### **1.3.First Example**

In the following simple example it is assumed that the JTAG-Booster is connected to LPT1 of your PC and target power is on.

Typing

```
JTAGEL5 /P MYAPP.BIN /VERIFY
```

at the DOS prompt results in the following output:

```
JTAGEL5 --- JTAG utility for AMD ÉlanSC520
Copyright © FS FORTH-SYSTEME GmbH, Breisach
Version 3.0 of mm/dd/yyyy

(1) Configuration loaded from file JTAGEL5.INI
(2) Target: FS FORTH-SYSTEME, EVA520
(3) Using LPT at I/O-address 0378h
(4) JTAG Adapter detected

(5) More than 9 devices detected in JTAG chain or TDI pin stuck at low level
    Device 0: IDCODE=10EFF003  AMD ÉlanSC520, Revision 1
    Device 1: IDCODE=10EFF003  AMD ÉlanSC520, Revision 1
    Device 2: IDCODE=10EFF003  AMD ÉlanSC520, Revision 1
    Device 3: IDCODE=10EFF003  AMD ÉlanSC520, Revision 1
    Device 4: IDCODE=10EFF003  AMD ÉlanSC520, Revision 1
    Device 5: IDCODE=10EFF003  AMD ÉlanSC520, Revision 1
    Device 6: IDCODE=10EFF003  AMD ÉlanSC520, Revision 1
    Device 7: IDCODE=10EFF003  AMD ÉlanSC520, Revision 1
    Device 8: IDCODE=10EFF003  AMD ÉlanSC520, Revision 1

(6) Sum of instruction register bits : 4
(7) CPU position                    : 0
(8) Instruction register offset     : 0

(9) AMD 29F040 detected
(10) Erasing Flash-EPROM Block #:6 7
    Programming File MYAPP.BIN
    131072 Bytes programmed
    Programming ok
```

Erase Time : 1.1 sec  
Programming Time : 121.2 sec

- (1) The initialization file JTAGEL5.INI was found in the current directory.
- (2) The target identification line of the initialization file is printed here.
- (3) The resulting I/O-address of the parallel port is printed here.
- (4) A JTAG-Booster is found on the parallel port
- (5) The JTAG chain is analyzed. There may be several parts in the JTAG chain. The chain is analyzed and all parts except the AMD ÉlanSC520 are switched to bypass mode.  
Please note: The current revision of the AMD ÉlanSC520 has a silicon bug with the JTAG identification register. As a result of that bug, the contents of the identification register is shifted out infinitely. If there are other devices in the JTAG chain, the AMD ÉlanSC520 must be the first part in the chain (nearest to TDI). Otherwise the JTAG-Booster does not work.
- (6) The length of all instruction registers in the JTAG chain are added.
- (7) The position of the AMD ÉlanSC520 in the JTAG chain is checked.
- (8) The position of the JTAG instruction register of the AMD ÉlanSC520 is checked
- (9) One Flash-EPROM AMD 29F040 selected with chip select BOOTCS# is found.
- (10) In this example two blocks must be erased.



## **1.4.Trouble Shooting**

Avoid long distances between your Host-PC and the target. If you are using standard parallel extension cable, the JTAG-BOOSTER may not work. Don't use Dongles between the parallel port and the JTAG-BOOSTER.

Switch off all special modes of your printer port (EPP, ECP, ...) in the BIOS setup. Only standard parallel port (SPP) mode is allowed.

On very fast PCs there could be verify errors. To avoid this, watch for the 'IO recovery time'-switch in the BIOS Setup which must be turned on. Otherwise try to slow down your PC by setting the turbo switch off.

When using older flash devices (nearly maximum erase cycles reached), we propose to use the /VERIFY option. This is also true for the relatively slow 3 Volt only flash devices.

Some newer fast flash devices need a setup time between address/data and the write strobe signal. If programming of this devices fails, try with the option /WRSETUP again.

If there are problems with autodetection of the flash devices use the /DEVICE= option. To speed up autodetection specify the option /16BIT or /8BIT.

Don't use hardware protected flash memories.

The used chip selects must be defined as output and inactive in the initialization file (see chapter 1.6 "Initialization file JTAGEL5.INI"). Also the address bits must be defined as output.

## **1.5.Error Messages**

- **80386 or greater required**  
The JTAG-BOOSTER does not work on a 8088/8086 or a 80286 platform.
- **Adapter not connected or target power fail**  
The JTAG-Booster wasn't found. Please check connection to parallel port and connection to target. Check target power. Check your BIOS-Setup.
- **Can't open x:\yyy\zzz\JTAGEL5.OVL**  
The overlay file JTAGEL5.OVL must be in the same directory as JTAGEL5.EXE.
- **Configuration file XYZ not found.**  
The file specified with the option /INI= wasn't found.
- **Device offset out of range**  
The value specified with the option /OFFSET= is greater than the size of the detected flash device.
- **Disk full**  
Writing a output file was aborted as a result of missing disk space.
- **Error creating file:**  
The output file could not be opened. Please check free disk space or write protection.
- **Error: *Pin-Name* is an output only pin**  
The specified pin cannot be sampled. Check the command line. Check the initialization file.
- **Error: *Pin-Name* is an input only pin**  
The specified pin cannot be activated. Check the command line. Check the initialization file.
- **Error: *Pin-Name* may not be read back**  
The specified pin can be switched to tristate, but cannot be read back. Check the command line.

- **illegal function:**  
The first parameter of the command line must be a valid function. See chapter 2 “JTAGEL5 Parameter Description” for a list of supported functions.
- **illegal number:**  
The specified number couldn't be interpret as a valid number. Check the relevant number base.
- **illegal option:**  
See chapter 2 “JTAGEL5 Parameter Description” for a list of supported options.
- **illegal Pin Type:**  
The name specified with the option /PIN= must be one of the list of chapter 1.6 “Initialization file JTAGEL5.INI”
- **illegal Flash Type:**  
The name specified with the option /DEVICE= must be one of the list of chapter 1.7 “Supported flash devices”.
- **Input file not found:**  
The specified file cannot be found
- **Input file is empty:**  
Files with zero length are not accepted
- **" " is undefined**  
Please check the syntax in your configuration file. (See chapter 1.6 “Initialization file JTAGEL5.INI”).
- **LPTx not installed**  
The LPT port specified with /LPTx cannot be found. Please check the LPT port or specify a installed LPT port. Check your BIOS setup.
- **missing filename**  
Most functions need a filename as second parameter.

- **missing option /I2CCLK=**  
Some functions need the option /I2CCLK= to be defined.
- **missing option /I2CDAT=**  
Some functions need the option /I2CDAT= or the options /I2CDATO= and /I2CDATI= to be defined.
- **missing option /LENGTH=**  
Some functions need the option /LENGTH= to be defined.
- **missing option /PIN=**  
Some functions need the option /PIN= to be defined.
- **More than 9 devices in the JTAG chain or TDI pin stuck at low level**  
The JTAG chain is limited to 9 parts. Check target power. Check the target's TDO pin.
- **No devices found in JTAG chain or TDI pin stuck at high level**  
A stream of 32 high bits was detected on the pin TDI. TDI may stuck at high level. Check the connection to your target. Check the target power. Check the target's TDO pin.
- **Option /CPUPOS= out of range**  
The number specified with the option /CPUPOS= must be less or equal to the number of parts minus 1.
- **Option /IROFFS= out of range**  
Please specify a smaller value
- **Part at specified position is not a AMD ÉlanSC520**  
The option /CPUPOS= points to a part not a AMD ÉlanSC520
- **Pins specified with /I2CCLK= and /I2CDAT= must have different control cells**  
The pin specified with the option /I2CDAT= must be able to be switched to high impedance while the pin specified with option /I2CCLK= is an active output. See chapter 1.6 "Initialization file JTAGEL5.INI".

- **Pins specified with /I2CCLK= and /I2CDATI= must have different control cells**  
The pin specified with the option /I2CDATI= must be able to be switched to high impedance while the pin specified with option /I2CCLK= is an active output. See chapter 1.6 “Initialization file JTAGEL5.INI”.
- **Pins specified with /I2CDATO= and /I2CDATI= must have different control cells**  
The pin specified with the option /I2CDATI= must be able to be switched to high impedance while the pin specified with option /I2CDATO= is an active output. See chapter 1.6 “Initialization file JTAGEL5.INI”.
- **Specify only one of that options:**  
Some options are exclusive (i.e. /8BIT and /16BIT). Don't mix them.
- **There are unknown parts in the JTAG chain. Please use the option /IROFFS= to specify the instr. reg. offset of the CPU.**  
If there are unknown parts in the JTAG chain, the program isn't able to determine the logical position of the CPU's instruction register.
- **There is no AMD ÉlanSC520 in the JTAG chain**  
No AMD ÉlanSC520 was found in the JTAG chain. Check the target power. Try with option /DRIVER=4 again.
- **Value of option /FILE-OFFSET out of range**  
The value of the option /FILE-OFFSET= points behind end of file.
- **wrong driver #**  
The value specified with the option /DRIVER= is out of range.
- **wrong Identifier (xxxx)**  
No valid identifier found. Check the specified chip select signal and the bus width. Try with the option /DEVICE= .

## **1.6.Initialization file JTAGEL5.INI**

This file is used to set the CPU signals for input/output. In case of output signal an additional parameter is used to set the default level to high or low. This file can be used to adapt your own AMD ÉlanSC520 design to the JTAG-BOOSTER. The Target-Entry is used to identify your design which is displayed with most commands.

When the JTAGEL5 software is started it scans the current directory for an existing initialization file named JTAGEL5.INI. If no entry is found the default values are used. You may also specify the initialization file with the option /INI= . If the specified file isn't found, the program aborts with an error message.

The CPU pins can also be used with the functions /BLINK (chapter 2.9), /PIN? (chapter 2.10) and /SAMPLE (chapter 2.11) to test the signals on your design.

### **Example of JTAGEL5.INI:**

```
// Description file for AMD ÉlanSC520
Target: FS FORTH-SYSTEME, EVA520
// All chip select signals are set to output and inactive.
// All signals should be defined. Undefined signals are set to their defaults.
// Pin names are defined in upper case.
// Low active signals are signed with a trailing #.

// Group A: All pins in this group must be set to the same direction
//      This pins are tristateable outputs and may not be read back
BA1      Out,Lo // SDRAM, bank address
BA0      Out,Lo // SDRAM, kank address
MA12     Out,Lo // SDRAM, address
MA11     Out,Lo //
MA10     Out,Lo //
MA9      Out,Lo //
MA8      Out,Lo //
MA7      Out,Lo //
MA6      Out,Lo //
MA5      Out,Lo //
MA4      Out,Lo //
MA3      Out,Lo //
MA2      Out,Lo //
```

---

MA1            Out,Lo  //  
MA0            Out,Lo  //

// Group B: All pins in this group must be set to the same direction

//        This pins are bidirectional

MD31          Inp        // SDRAM data bus  
MD30          Inp        //  
MD29          Inp        //  
MD28          Inp        //  
MD27          Inp        //  
MD26          Inp        //  
MD25          Inp        //  
MD24          Inp        //  
MD23          Inp        //  
MD22          Inp        //  
MD21          Inp        //  
MD20          Inp        //  
MD19          Inp        //  
MD18          Inp        //  
MD17          Inp        //  
MD16          Inp        //  
MD15          Inp        //  
MD14          Inp        //  
MD13          Inp        //  
MD12          Inp        //  
MD11          Inp        //  
MD10          Inp        //  
MD9           Inp        //  
MD8           Inp        //  
MD7           Inp        //  
MD6           Inp        //  
MD5           Inp        //  
MD4           Inp        //  
MD3           Inp        //  
MD2           Inp        //  
MD1           Inp        //  
MD0           Inp        //  
MECC6        Inp        // SDRAM, memory error correction code  
MECC5        Inp        //  
MECC4        Inp        //  
MECC3        Inp        //

```
MECC2      Inp      //
MECC1      Inp      //
MECC0      Inp      //

// Group C: All pins in this group must be set to the same direction
//      This pins are tristateable outputs but may not be read back
SCS3#      Out,Hi   // SDRAM, chip select
SCS2#      Out,Hi   //
SCS1#      Out,Hi   //
SCS0#      Out,Hi   //

// Group D: All pins in this group must be set to the same direction
//      This pins are tristateable outputs but may not be read back
SRASB#     Out,Hi   // SDRAM, row address strobe
SRASA#     Out,Hi   //

// Group E: All pins in this group must be set to the same direction
//      This pins are tristateable outputs but may not be read back
SCASB#     Out,Hi   // SDRAM, column address strobe
SCASA#     Out,Hi   //

// Group F: All pins in this group must be set to the same direction
//      This pins are tristateable outputs but may not be read back
SWEB#      Out,Hi   // SDRAM, memory write enables
SWEA#      Out,Hi   //

// Group G: All pins in this group must be set to the same direction
//      This pins are tristateable outputs but may not be read back
SDQM3      Out,Lo   // SDRAM, data ubput/output mask
SDQM2      Out,Lo   //
SDQM1      Out,Lo   //
SDQM0      Out,Lo   //

// Group H: All pins in this group must be set to the same direction
//      This pins are bidirectional
AD31       Inp      // PCI, address/data bus
AD30       Inp      //
AD29       Inp      //
AD28       Inp      //
AD27       Inp      //
AD26       Inp      //
```



```

AD25      Inp    //
AD24      Inp    //
AD23      Inp    //
AD22      Inp    //
AD21      Inp    //
AD20      Inp    //
AD19      Inp    //
AD18      Inp    //
AD17      Inp    //
AD16      Inp    //
AD15      Inp    //
AD14      Inp    //
AD13      Inp    //
AD12      Inp    //
AD11      Inp    //
AD10      Inp    //
AD9       Inp    //
AD8       Inp    //
AD7       Inp    //
AD6       Inp    //
AD5       Inp    //
AD4       Inp    //
AD3       Inp    //
AD2       Inp    //
AD1       Inp    //
AD0       Inp    //

```

// Group I: All pins in this group must be set to the same direction

// This pins are bidirectional

```

CBE3#     Out,Hi // PCI, command or byte enable
CBE2#     Out,Hi //
CBE1#     Out,Hi //
CBE0#     Out,Hi //

```

// Group J: All pins in this group must be set to the same direction

// Pins GPA14..0 are tristateable outputs but may not be read back

// Pins GPA25..15 are bidirectional

// For Flash programming this pins must be set to output

```

GPA25     Out,Lo // = DEBUG_ENTER config switch
GPA24     Out,Lo // = INST_TRCE config switch
GPA23     Out,Lo // = AMDEBUG_DIS config switch

```

GPA22	Out,Lo	// = RSTLD7 config switch
GPA21	Out,Lo	// = RSTLD6 config switch
GPA20	Out,Lo	// = RSTLD5 config switch
GPA19	Out,Lo	// = RSTLD4 config switch
GPA18	Out,Lo	// = RSTLD3 config switch
GPA17	Out,Lo	// = RSTLD2 config switch
GPA16	Out,Lo	// = RSTLD1 config switch
GPA15	Out,Lo	// = RSTLD0 config switch
GPA14	Out,Lo	//
GPA13	Out,Lo	//
GPA12	Out,Lo	//
GPA11	Out,Lo	//
GPA10	Out,Lo	//
GPA9	Out,Lo	//
GPA8	Out,Lo	//
GPA7	Out,Lo	//
GPA6	Out,Lo	//
GPA5	Out,Lo	//
GPA4	Out,Lo	//
GPA3	Out,Lo	//
GPA2	Out,Lo	//
GPA1	Out,Lo	//
GPA0	Out,Lo	//

// Group K: All pins in this group must be set to the same direction

// This pins are bidirectional

GPD15	Inp	//
GPD14	Inp	//
GPD13	Inp	//
GPD12	Inp	//
GPD11	Inp	//
GPD10	Inp	//
GPD9	Inp	//
GPD8	Inp	//

// Group L: All pins in this group must be set to the same direction

// This pins are bidirectional

GPD7	Inp	//
GPD6	Inp	//
GPD5	Inp	//
GPD4	Inp	//

```
GPD3      Inp    //
GPD2      Inp    //
GPD1      Inp    //
GPD0      Inp    //
```

```
// The direction of each following pin can be set independent of the others,
// but this pins can not be read back.
```

```
CLKMEMOUT Out,Lo// SDRAM, clock output
BOOTCS#   Out,Hi//
ROMRD#    Out,Hi//
FLASHWR#  Out,Hi//
ROMBUFOE# Out,Hi//
ROMCS1#   Out,Hi//
ROMCS2#   Out,Hi //
CLKPCIOUT Out,Lo // PCI, clock input
RST#      Out,Hi // PCI, reset
GNT4#     Out,Hi //
GNT3#     Out,Hi //
GNT2#     Out,H  i//
GNT1#     Out,Hi //
GNT0#     Out,Hi //
GPRESET   Out,Lo // some people connect GPRESET to the Boot-Flash!!
GPIORD#   Out,Hi //
GPIOWR#   Out,Hi //
GPMEMRD#  Out,Hi //
GPMEMWR#  Out,Hi //
SOUT1     Out,Lo //
RTS1#     Out,Lo //
DTR1#     Out,Lo //
SOUT2     Out,Lo //
RTS2#     Out,Lo //
DTR2#     Out,Lo //
SSI_CLK   Out,Hi //
SSI_DO    Out,Hi //
CMDACK    Out,Lo //
STOP/TX   Out,Lo //
TRIG/TRACE Out,Lo //
```

```
// The following pins are complete bidirectional pins.
// The direction of each pin can be set independent of the other pins.
// Each pin can be used as input.
```

PAR	Inp	//
PERR#	Inp	//
FRAME#	Inp	//
TRDY#	Inp	//
IRDY#	Inp	//
STOP#	Inp	//
DEVSEL#	Inp	//
PIO27	Inp	// = GPCS0#
PIO26	Inp	// = PMEMCS16#
PIO25	Inp	// = GPIOCS16#
PIO24	Out,Hi	// = GPDBUFOE#
PIO23	Inp	// = GPIRQ0
PIO22	Inp	// = GPIRQ1
PIO21	Inp	// = GPIRQ2
PIO20	Inp	// = GPIRQ3
PIO19	Inp	// = GPIRQ4
PIO18	Inp	// = GPIRQ5
PIO17	Inp	// = GPIRQ6
PIO16	Inp	// = GPIRQ7
PIO15	Inp	// = GPIRQ8
PIO14	Inp	// = GPIRQ9
PIO13	Inp	// = GPIRQ10
PIO12	Out,Hi	// = GPDACK0#
PIO11	Out,Hi	// = GPDACK1#
PIO10	Out,Hi	// = GPDACK2#
PIO9	Out,Hi	// = GPDACK3#
PIO8	Inp	// = GPDRQ0
PIO7	Inp	// = GPDRQ1
PIO6	Inp	// = GPDRQ2
PIO5	Inp	// = GPDRQ3
PIO4	Out,Lo	// = GPTC
PIO3	Out,Lo	// = GPAEN
PIO2	Inp	// = GPRDY
PIO1	Out,Hi	// = GPBHE#
PIO0	Out,Lo	// = CPALE
PIO28	Inp	// = CTS2#
PIO29	Inp	// = DSR2#
PIO30	Inp	// = DCD2
PIO31	Inp	// = RIN2#
CLKTIMER	Inp	//
DC	Out,Lo	//

```

DATASTRB    Out,Lo  //
CPUACT      Out,Lo  //
PITOUT2     Out,Lo  //
PITGATE2    Inp     //
TMRIN1      Inp     //
TMRIN0      Inp     //
TMROUT1     Out,Lo  //
TMROUT0     Out,Lo  //

```

// The following pins are input only.

// Setting to output of one of these pins results in an error.

// Declaration of the direction of these pins is optional.

```

CLKMEMIN    Inp     //
SERR#       Inp     //
CLKPCIIN    Inp     //
INTD#       Inp     //
INTC#       Inp     //
INTB#       Inp     //
INTA#       Inp     //
REQ4#       Inp     //
REQ3#       Inp     //
REQ2#       Inp     //
REQ1#       Inp     //
REQ0#       Inp     //
SIN1        Inp     //
CTS1#       Inp     //
DSR1#       Inp     //
DCD1#       Inp     //
RIN1#       Inp     //
SIN2        Inp     //
SSI_DI      Inp     //
PWRGOOD     Inp     //
PRGRESET    Inp     //
BR/TC       Inp     //

```

This example is equal to the default initialization which is used when no initialization file could be found in the current directory and no initialization file is specified with the option /INI=.

Changes to the structure of the file could result in errors. Remarks can be added by using //.

## **1.7.Supported flash devices**

The following types could be used with the /DEVICE= option:

AM29F010	: AMD 29F010	
AM29F010*2	: Dual AMD 29F010	
* AM29LV010	: AMD 29LV010	(3.3V)
* AM29LV010*2	: Dual AMD 29LV010	(3.3V)
* AM29F100BW	: AMD 29F100B	(word mode)
* AM29F100BB	: AMD 29F100B	(byte mode)
* AM29F100TW	: AMD 29F100T	(word mode)
* AM29F100TB	: AMD 29F100T	(byte mode)
* AM29F200BW	: AMD 29F200B	(word mode)
* AM29F200BB	: AMD 29F200B	(byte mode)
* AM29F200TW	: AMD 29F200T	(word mode)
* AM29F200TB	: AMD 29F200T	(byte mode)
* AM29LV200BW	: AMD 29F200B	(3.3V, word mode)
* AM29LV200BB	: AMD 29F200B	(3.3V, byte mode)
* AM29LV200TW	: AMD 29F200T	(3.3V, word mode)
* AM29LV200TB	: AMD 29F200T	(3.3V, byte mode)
AM29F040	: AMD 29F040	
AM29F040*2	: Dual AMD 29F040	
* AM29F400BW	: AMD 29F400B	(word mode)
* AM29F400BB	: AMD 29F400B	(byte mode)
AM29F400TW	: AMD 29F400T	(word mode)
AM29F400TB	: AMD 29F400T	(byte mode)
* AM29LV400BW	: AMD 29LV400B	(3.3V, word mode)
* AM29LV400BB	: AMD 29LV400B	(3.3V, byte mode)
* AM29LV400TW	: AMD 29LV400T	(3.3V, word mode)
* AM29LV400TB	: AMD 29LV400T	(3.3V, byte mode)
* AM29LV004B	: AMD 29LV004B	(3.3V)
* AM29LV004T	: AMD 29LV004T	(3.3V)
AM29F080	: AMD 29F080	
* AM29F080*2	: Dual AMD 29F080	
* AM29LV081	: AMD 29LV081	(3.3V)
* AM29LV081*2	: Dual 29LV081	(3.3V)
* AM29F800BW	: AMD 29F800B	(word mode)
* AM29F800BB	: AMD 29F800B	(byte mode)
AM29F800TW	: AMD 29F800T	(word mode)
* AM29F800TB	: AMD 29F800T	(byte mode)
* AM29LV800BW	: AMD 29LV800B	(3.3V, word mode)

* AM29LV800BB	: AMD 29LV800B	(3.3V, byte mode)
AM29LV800TW	: AMD 29LV800T	(3.3V, word mode)
* AM29LV800TB	: AMD 29LV800T	(3.3V, byte mode)
* AM29LV008T	: AMD 29LV008T	(3.3V)
* AM29LV008B	: AMD 29LV008B	(3.3V)
AM29F016	: AMD 29F016	
AM29F016*2	: Dual AMD 29F016	
* AM29F017	: AMD 29F017	
AM29F017*2	: Dual AMD 29F017	
AM29LV017*2	: Dual AMD 29LV017	(3.3V)
* AM29F160BW	: AMD 29F160B	(word mode)
* AM29F160BB	: AMD 29F160B	(byte mode)
* AM29F160TW	: AMD 29F160T	(word mode)
* AM29F160TB	: AMD 29F160T	(byte mode)
* AM29F160BB*2	: Dual AMD 29F160B	(byte mode)
* AM29F160TB*2	: Dual AMD 29F160T	(byte mode)
AM29LV160BW	: AMD 29LV160B	(3.3V, word mode)
* AM29LV160BB	: AMD 29LV160B	(3.3V, byte mode)
* AM29LV160TW	: AMD 29LV160T	(3.3V, word mode)
* AM29LV160TB	: AMD 29LV160T	(3.3V, byte mode)
AM29LV160BB*2	: Dual AMD 29LV160B	(3.3V, byte mode)
* AM29LV160TB*2	: Dual AMD 29LV160T	(3.3V, byte mode)
AM29F032	: AMD 29F032	
AM29F032*2	: Dual AMD 29F032	
* AM29LV033	: AMD 29LV033	(3.3V)
* AM29LV033*2	: Dual AMD 29F033	(3.3V)
* AM29LV640	: AMD 29LV160	(3.3V, word mode)
* I28F001T	: Intel 28F001T	
* I28F001T*2	: Dual Intel 28F001T	
* I28F001B	: Intel 28F001B	
* I28F200BW	: Intel 28F200B	(word mode)
* I28F200BB	: Intel 28F200B	(byte mode)
* I28F200TW	: Intel 28F200T	(word mode)
* I28F200TB	: Intel 28F200T	(byte mode)
* I28F002B	: Intel 28F002B	
* I28F002T	: Intel 28F002T	
* I28F400BW	: Intel 28F400B	(word mode)
* I28F400BB	: Intel 28F400B	(byte mode)
I28F400TW	: Intel 28F400T	(word mode)
I28F400TB	: Intel 28F400T	(byte mode)

* I28F004B	: Intel 28F004B	
* I28F004T	: Intel 28F004T	
* I28F400B3B	: Intel 28F400B3B	Boot Block Smart3 Bottom
* I28F400B3T	: Intel 28F400B3T	Boot Block Smart3 Top
* I28F004S5	: Intel 28F004	FlashFile Smart3/5
* I28F800BW	: Intel 28F800B	(word mode)
* I28F800BB	: Intel 28F800B	(byte mode)
I28F800TW	: Intel 28F800T	(word mode)
* I28F800TB	: Intel 28F800T	(byte mode)
* I28F800B3B	: Intel 28F800B3B	Boot Block Smart3 Bottom
* I28F800B3T	: Intel 28F800B3T	Boot Block Smart3 Top
* I28F008B	: Intel 28F008B	
* I28F008T	: Intel 28F008T	
I28F008SA	: Intel 28F008	FlashFile 12V
I28F008SA*2	: Dual Intel 28F008	FlashFile 12V
I28F008S5	: Intel 28F008	FlashFile Smart3/5
I28F008S5*2	: Dual Intel 28F008	FlashFile Smart3/5
I28F016W	: Intel 28F016	FlashFile (word mode)
* I28F016B	: Intel 28F016	FlashFile (byte mode)
* I28F016S5	: Intel 28F016	FlashFile Smart3/5
* I28F160B3B	: Intel 28F160	Boot Block Smart3 Bottom
* I28F160B3T	: Intel 28F160	Boot Block Smart3 Top
* I28F160S5W	: Intel 28F160	FlashFile Smart5 (word mode)
* I28F160S5B	: Intel 28F160	FlashFile Smart5 (byte mode)
I28F320S5W	: Intel 28F320	FlashFile Smart3/5 (word mode)
* I28F320S5B	: Intel 28F320	FlashFile Smart3/5 (byte mode)
* I28F320J5W	: Intel 28F320	StrataFlash (word mode)
* I28F320J5B	: Intel 28F320	StrataFlash (byte mode)
* I28F320J3W	: Intel 28F320	StrataFlash (3.3V, word mode)
* I28F320J3B	: Intel 28F320	StrataFlash (3.3V, byte mode)
* I28F640J5W	: Intel 28F640	StrataFlash (word mode)
* I28F640J5B	: Intel 28F640	StrataFlash (byte mode)
* I28F640J3W	: Intel 28F640	StrataFlash (3.3V, word mode)
* I28F640J3B	: Intel 28F640	StrataFlash (3.3V, byte mode)
* I28F128J3W	: Intel 28F128	StrataFlash (3.3V, word mode)
* I28F128J3B	: Intel 28F128	StrataFlash (3.3V, byte mode)
* MBM29F200BW	: Fujitsu 29F200B	(word mode)
* MBM29F200BB	: Fujitsu 29F200B	(byte mode)
* MBM29F200TW	: Fujitsu 29F200T	(word mode)
* MBM29F200TB	: Fujitsu 29F200T	(byte mode)



---

* MBM29LV200BW	: Fujitsu 29LV200B	(3.3V, word mode)
* MBM29LV200BB	: Fujitsu 29LV200B	(3.3V, byte mode)
* MBM29LV200TW	: Fujitsu 29LV200T	(3.3V, word mode)
* MBM29LV200TB	: Fujitsu 29LV200T	(3.3V, byte mode)
* MBM29F002B	: Fujitsu 29F002B	
* MBM29F002SB	: Fujitsu 29F002SB	(TSOP40)
* MBM29LV002B	: Fujitsu 29LV002B	(3.3V)
* MBM29F002T	: Fujitsu 29F002T	
* MBM29F002ST	: Fujitsu 29F002ST	(TSOP40)
* MBM29LV002T	: Fujitsu 29LV002T	(3.3V)
* MBM29F040	: Fujitsu 29F040	
* MBM29F400BW	: Fujitsu 29F400B	(word mode)
* MBM29F400BB	: Fujitsu 29F400B	(byte mode)
* MBM29F400TW	: Fujitsu 29F400T	(word mode)
* MBM29F400TB	: Fujitsu 29F400T	(byte mode)
* MBM29LV400BW	: Fujitsu 29LV400B	(3.3V, word mode)
* MBM29LV400BB	: Fujitsu 29LV400B	(3.3V, byte mode)
* MBM29LV400TW	: Fujitsu 29LV400T	(3.3V, word mode)
* MBM29LV400TB	: Fujitsu 29LV400T	(3.3V, byte mode)
* MBM29LV004B	: Fujitsu 29LV004B	(3.3V)
* MBM29LV004T	: Fujitsu 29LV004T	(3.3V)
* MBM29F080	: Fujitsu 29F080	
* MBM29LV080	: Fujitsu 29LV080	(3.3V)
* MBM29F800BW	: Fujitsu 29F800B	(word mode)
* MBM29F800BB	: Fujitsu 29F800B	(byte mode)
* MBM29F800TW	: Fujitsu 29F800T	(word mode)
* MBM29F800TB	: Fujitsu 29F800T	(byte mode)
* MBM29LV800BW	: Fujitsu 29LV800B	(3.3V, word mode)
* MBM29LV800BB	: Fujitsu 29LV800B	(3.3V, byte mode)
* MBM29LV800TW	: Fujitsu 29LV800T	(3.3V, word mode)
* MBM29LV800TB	: Fujitsu 29LV800T	(3.3V, byte mode)
* MBM29LV008B	: Fujitsu 29LV008B	(3.3V)
* MBM29LV008T	: Fujitsu 29LV008T	(3.3V)
* MBM29F016	: Fujitsu 29F016	
* MBM29F016*2	: Dual Fujitsu 29F016	
* MBM29F017	: Fujitsu 29F017	
* MBM29F017*2	: Dual Fujitsu 29F017	
* MBM29F160BW	: Fujitsu 29LV160B	(word mode)
* MBM29F160BB	: Fujitsu 29LV160B	(byte mode)
* MBM29F160TW	: Fujitsu 29LV160T	(word mode)
* MBM29F160TB	: Fujitsu 29LV160T	(byte mode)

* MBM29F160BB*2	: Dual Fujitsu 29LV160B	(byte mode)
* MBM29F160TB*2	: Dual Fujitsu 29LV160T	(byte mode)
* MBM29LV160BW	: Fujitsu 29LV160B	(3.3V, word mode)
* MBM29LV160BB	: Fujitsu 29LV160B	(3.3V, byte mode)
* MBM29LV160TW	: Fujitsu 29LV160T	(3.3V, word mode)
* MBM29LV160TB	: Fujitsu 29LV160T	(3.3V, byte mode)
MBM29LV160BB*2	: Dual Fujitsu 29LV160B	(3.3V, byte mode)
* MBM29LV160TB*2	: Dual Fujitsu 29LV160T	(3.3V, byte mode)
MBM29F032	: Fujitsu 29F032	
MBM29F032*2	: Dual Fujitsu 29F032*2	
* M29F100BW	: ST 29F100B	(word mode)
* M29F100BB	: ST 29F100B	(byte mode)
* M29F100TW	: ST 29F100T	(word mode)
* M29F100TB	: ST 29F100T	(byte mode)
M29F200BW	: ST 29F200B	(word mode)
* M29F200BB	: ST 29F200B	(byte mode)
* M29F200TW	: ST 29F200T	(word mode)
* M29F200TB	: ST 29F200T	(byte mode)
* M29F040	: ST 29F040	
* M29F040*2	: Dual ST 29F040	
* M29W040	: ST 29W040	(3.3V)
* M29W040*2	: Dual ST 29W040	(3.3V)
* M29F400BW	: ST 29F400B	(word mode)
* M29F400BB	: ST 29F400B	(byte mode)
* M29F400TW	: ST 29F400T	(word mode)
* M29F400TB	: ST 29F400T	(byte mode)
* M29W400BW	: ST 29W400B	(3.3V, word mode)
* M29W400BB	: ST 29W400B	(3.3V, byte mode)
* M29W400TW	: ST 29W400T	(3.3V, word mode)
* M29W400TB	: ST 29W400T	(3.3V, byte mode)
* M29W004B	: ST 29W004B	(3.3V)
* M29W004T	: ST 29W004T	(3.3V)
* M29F800BW	: ST 29F800B	(word mode)
* M29F800BB	: ST 29F800B	(byte mode)
* M29F800TW	: ST 29F800T	(word mode)
* M29F800TB	: ST 29F800T	(byte mode)

The flash devices signed with '\*' are not yet tested.

## 2. JTAGEL5 Parameter Description

When you start JTAGEL5.EXE without any parameters the following help screen with all possible functions and options is displayed:

```
JTAGEL5 --- JTAG utility for the AMD ÉlanSC520
Copyright © FS FORTH-SYSTEME GmbH, Breisach
Version 3.0 of mm/dd/yyyy
```

Programming of Flash-EPROMs and Debugging on targets with the AMD ÉlanSC520.

The JTAG-Booster is needed to connect the parallel port of the PC to the JTAG port of the AMD ÉlanSC520.

Usage: JTAGEL5 /function [filename] [/option\_1] ... [/option\_n]

Supported functions:

```
/P      : Programming a Flash Device
/R      : Read a Flash Device to file
/V      : Verify a Flash Device with file
/DUMP   : Make a target dump
/PI2C   : Program an I2C Device with file
/RI2C   : Read an I2C Device to file
/VI2C   : Verify an I2C Device with file
/DUMPI2C : Make a dump of an I2C Device
/BLINK  : Toggle a CPU pin
/PIN?   : Test a CPU pin
/SAMPLE : Test a CPU pin while CPU is running
/LIST   : Print a list of supported Flash devices
```

Supported Options:

```
/BOOTCS   /ROMCS1   /ROMCS2   /NOCS     /WRSETUP
/VERIFY   /TOP       /PAUSE    /P        /NODUMP
/NOERASE  /LATTICE   /ERASEALL /LPT1     /LPT2
/LPT3     /LPT-BASE= /16BIT    /8BIT     /NOMAN
/32H      /32L       /MBUS     /LENGTH=  /L=
/FILE-OFFSET= /FO=       /OFFSET=  /O=
/DELAY=   /DEVICE-BASE= /DB=      /DRIVER=
/DMASK=   /DM=       /IROFFS=  /CPUPOS=  /DEVICE=
/PIN=     /I2CCLK=   /I2CDAT=  /I2CDATI= /I2CDATO=
/WATCH=   /OUT=      /INI=
```

The following options are valid for most functions:

`/DRIVER=x` with  $x = 1,2,3,4$

A driver for the interface to the JTAG-BOOSTER on the parallel port may be specified. `/DRIVER=1` selects the fastest available driver, `/DRIVER=4` selects the slowest one. Use a slower driver if there are problems with JTAG-BOOSTER.

Default: `/DRIVER=3`

`/INI=file`

An initialization file may be specified. By default the current directory is searched for the file `JTAGEL5.INI`. If this file is not found and no initialization file is specified in the command line, default initialization values are used (see also chapter 1.6 "Initialization file `JTAGEL5.INI`").

Default: `/INI=JTAGEL5.INI`

`/LATTICE`

For demonstration purposes this software works with the Lattice ispLSI-Adapter, too. With the option `/LATTICE` you can simulate the speed achievable with the simple ispLSI-Adapter.

`/LPT1 /LPT2 /LPT3`

A printer port may be specified where the JTAG-Booster resides.

Default: `/LPT1`

`/LPT-BASE`

The physical I/O-Address of printer port may be specified instead of the logical printer name.

`/OUT=file_or_device`

All screen outputs are redirected to the specified file or device. Note that you can't redirect to the same parallel port where the JTAG-Booster resides.

Default: `/OUT=CON`

`/PAUSE`

With the option `/PAUSE` you can force the program to stop after each screen. Please do not use this option if you redirect the output to a file.

Abbreviation: `/P`

`/WATCH=`

With the option `/WATCH=` a pin can be specified, which is toggled twice per second, while the program is active. This pin may be the trigger of a watchdog. This pin must be specified as output in the initialization file.

## **2.1.Programming a Flash Device**

**Usage:** JTAGEL5 /P filename [optionlist]

The specified file is programmed into the flash memory. Finally a complete verify is done, if the option /VERIFY is omitted. If the verify fails, the contents of the flash memory is written to a file with the extension DMP.

The type of the flash device is normally detected by the software. When autodetect fails you should use the /DEVICE= option to set the right flash device. The known devices are shown in chapter 1.7 “Supported flash devices”.

### **Options:**

/DEVICE=devicename

The device is detected automatically by switching to autoselect mode. In case of trouble you should select the device by using this parameter to avoid autodetection.

/NOMAN

If you use a flash device which is identical to one of the supported parts, but is from a different manufacturer, with this option you can suppress the comparison of the manufacturer identification code. We recommend to use this option together with the /DEVICE= option to avoid failures in autodetection.

/DEVICE-BASE=hhhhh<sup>1</sup>

By default a device start address of 3000000h (=48MByte) is used for accesses to the flash device.

Default: /DEVICE-BASE=3000000

Abbreviation: /DB=

/OFFSET=hhhhh

The programming starts at an offset of hhhhh relative to the start address of the flash device. If the offset is negative, the offset specifies an address relative to the end of the flash device. See also option /TOP

Default: /OFFSET=0

Abbreviation: /O=

<sup>1</sup>hhhhh=number base is hex

**/TOP**

If the option /TOP is used the option /OFFSET= specifies the address where the programming ends (plus one) instead of the starting address. This option is very important for Intel CPU architectures, because target execution always starts at the top of the address space.

**/FILE-OFFSET=hhhhh**

If FILE-OFFSET is specified, the first hhhhh bytes of the file are skipped and not programmed to target.

Default: /FILE-OFFSET=0

Abbreviation: /FO=

**/LENGTH=hhhhh**

The number of programmed bytes may be limited to LENGTH. If no LENGTH is specified the whole file is programmed.

Default: /LENGTH=4000000 (64 MByte)

Abbreviation: /L=

**/VERIFY**

If this option is specified, the result is verified on a cell by cell (cell=8bit or 16bit) basis instead of a complete verify after programming. If you want both a cell by cell verify and a complete verify after programming, please use a additional command line with the verify function. See chapter 2.3 "Verify a Flash Device with file".

**/NODUMP**

In case of a verify error the contents of the flash memory is written to a file with the extension .DMP. With /NODUMP you can suppress this feature.

**/ERASEALL**

Erase the whole flash device. If this option isn't set, only those blocks are erased where new data should be written to.

**/NOERASE**

This option prevents the flash device from being erased.

**/BOOTCS /ROMCS1 /ROMCS2**

This options may be used to specify one or more chip select signals to the flash memory. The used chip selects must be defined as output and inactive in the initialization file. (See chapter 1.6 "Initialization file JTAGEL5.INI".)

Default: /BOOTCS

**/NOCS**

Use this option to switch off all chip select signals. This may be necessary if the device's chip select is generated via a normal decoder instead of using the AMD ÉlanSC520 chip select unit.

**/8BIT /16BIT**

Specifies the bus interface to the target device. You can speed up autodetection, if you specify the correct bus interface width.

**/32L /32H**

The JTAG-Booster is not able to handle the interface to a dual 16bit ROM (32bit-ROM). With this two options you can select one 16 bit half of a 32bit-ROM. The option /32L selects the low word and /32H selects the high word. 32 bit flash eproms are always connected to the SDRAM data bus. It is not necessary to specify the option /MBUS if the option /32L or /32H is used. Do not specify the option /8BIT together with /32L or /32H.

**/MBUS**

With this option the SDRAM data bus (MDx bus) is used instead of the general purpose data bus (GPDx bus) for accesses to flash eproms.

**/WRSETUP**

By default write cycles to the Flash EPROM start with address, data and write strobe set at the same time. With the option /WRSETUP you can force the program to generate a setup time for address and data with respect to the write strobe.



**Examples:**

JTAGEL5 /P ROMDOS.ROM /VERIFY /L=20000 /TOP

This example programs up to 128 Kbytes of the file ROMDOS.ROM (with i.e. 512 Kbytes) to the top of the flash memory.

JTAGEL5 /P CE.EVN /VERIFY /32L /ROMCS1

This example programs the file CE.EVN to the lower word of a 32bit-ROM connected to ROMCS1#.

## **2.2.Read a Flash Device to file**

**Usage:** JTAGEL5 /R filename [optionlist]

The contents of a flash device is read and written to a file.

The type of flash device is normally detected by the software. When autodetect fails you should use the /DEVICE= option to set the right flash device. The known devices are shown in chapter 1.7 "Supported flash devices".

### **Options:**

/DEVICE=devicename

See function /P (Chapter 2.1)

/NOMAN

See function /P (Chapter 2.1)

/DEVICE-BASE=hhhhh<sup>2</sup>

See function /P (Chapter 2.1)

/OFFSET=hhhhh

Reading of the flash memory starts at an offset of hhhhh relative to the start address of the flash device. If the offset is negative, the offset specifies a address relative to the end of the flash device.

See also option /TOP.

Default: /OFFSET=0

Abbreviation: /O=

/TOP

If the option /TOP is used the option /OFFSET= specifies the address where reading ends (plus one) instead of the starting address.

/LENGTH=hhhhh

The number of read bytes may be limited to LENGTH. If no LENGTH is specified the whole flash device is read (if no offset is specified).

<sup>2</sup>hhhhh=number base is hex

/BOOTCS /ROMCS1 /ROMCS2 /NOCS

See function /P (Chapter 2.1)

/8BIT /16BIT

See function /P (Chapter 2.1)

/32L /32H

See function /P (Chapter 2.1)

/MBUS

See function /P (Chapter 2.1)

/WRSETUP

See function /P (Chapter 2.1)

Please note: In the function /R write cycles are needed to detect the type of the flash memory.

**Example:** JTAGEL5 /R BIOS.ABS /L=10000 /TOP

This example may be used to read the upper most 64 Kbyte of the flash memory to the file BIOS.ABS.

### **2.3.Verify a Flash Device with file**

**Usage:** JTAGEL5 /V filename [optionlist]

The contents of a flash device is compared with the specified file. If there are differences the memory is dumped to a file with the extension DMP.

The type of flash device is normally detected by the software. When autodetect fails you should use the /DEVICE= option to set the right flash device. The known devices are shown in chapter 1.7 "Supported flash devices".

#### **Options:**

/DEVICE=devicename

See function /P (Chapter 2.1)

/NOMAN

See function /P (Chapter 2.1)

/DEVICE-BASE=hhhhhh

See function /P (Chapter 2.1)

/OFFSET=hhhhhh

See function /P (Chapter 2.1)

/TOP

See function /P (Chapter 2.1)

/FILE-OFFSET=hhhhhh

See function /P (Chapter 2.1)

/LENGTH=hhhhhh

See function /P (Chapter 2.1)

/NODUMP

See function /P (Chapter 2.1)

/BOOTCS /ROMCS1 /ROMCS2 /NOCS

See function /P (Chapter 2.1)

/8BIT /16BIT

See function /P (Chapter 2.1)

/32L /32H

See function /P (Chapter 2.1)

/MBUS

See function /P (Chapter 2.1)

/WRSETUP

See function /P (Chapter 2.1)

Please note: In the function /V write cycles are needed to detect the type of the flash memory.

**Example:** JTAGEL5 /V ROMDOS.ROM /L=20000 /TOP

This example may be used to verify the upper most 128 Kbytes of the flash memory with the file ROMDOS.ROM (with i.e. 512 Kbytes).

## **2.4.Dump target memory**

**Usage:** JTAGEL5 /DUMP [optionlist]

A Hex-Dump of the target memory is printed on the screen, if not redirected to file or device.

### **Options:**

/OFFSET=hhhhhh

The memory dump starts at an offset of hhhhhh.

Default: /OFFSET=0

Abbreviation: /O=

/TOP

If the option /TOP is used the option /OFFSET= specifies the address where the dump ends (plus one) instead of the starting address

/LENGTH=hhhhhh

Default: /LENGTH=100

Abbreviation: /L=

/BOOTCS /ROMCS1 /ROMCS2 /NOCS

See function /P (Chapter 2.1)

Default: /BOOTCS

/8BIT /16BIT

Default: /16BIT

/32L /32H

See function /P (Chapter 2.1)

/MBUS

See function /P (Chapter 2.1)

**Example:** JTAGEL5 /DUMP /BOOTCS

This example makes a memory dump of the first 256 bytes of the Boot-EPROM.

## **2.5.Program an I<sup>2</sup>C-Device**

**Usage:** JTAGEL5 /PI2C filename [optionlist]

The specified file is programmed to a I<sup>2</sup>C-Device (i.e. a serial EEPROM) connected to pins of the CPU. Finally a complete verify is done. If the verify fails, the contents of the I<sup>2</sup>C-Device is written to a file with the extension DMP.

Two methods to connect the I<sup>2</sup>C-Device to the CPU are supported. The first method is to use two CPU pins, one pin for clock output (I2CCLK) and one pin for serial data input and output (I2CDAT). The second method is to use one pin for clock output (I2CCLK), one for serial data input (I2CDATI) and one for serial data output (I2CDATO).

### **Options:**

/DEVICE-BASE=hhhhhh<sup>3</sup>

By default a device start address of 3000000h (=48MByte) is used for accesses to the flash device.

Default: /DEVICE-BASE=3000000

Abbreviation: /DB=

/OFFSET=hhhhhh

The programming starts at an offset of hhhhhh relative to the start address of the I<sup>2</sup>C-Device.

Default: /OFFSET=0

Abbreviation: /O=

/FILE-OFFSET=hhhhhh

If FILE-OFFSET is specified, the first hhhhhh bytes of the file are skipped and not programmed to target.

Default: /FILE-OFFSET=0

Abbreviation: /FO=

<sup>3</sup>hhhhhh=number base is hex

`/LENGTH=hhhhh`

The number of programmed bytes may be limited to LENGTH. If no LENGTH is specified the whole file is programmed.

Abbreviation: `/L=`

`/NODUMP`

In case of a verify error the contents of the I<sup>2</sup>C-Device is written to a file with the extension .DMP. With option `/NODUMP` you can suppress this feature.

`/I2CCLK=pin_name`

Specifies the CPU pin used for serial clock output.

`/I2CDAT=pin_name`

Specifies the CPU pin used for serial data input and output. Pin\_name must specify a bidirectional pin otherwise an error message occurs. Instead of one bidirectional pin one pin for serial data input and one for serial data output may be used. See option `/I2CDATO=` and `/I2CDATI=` .

`/I2CDATO=pin_name`

Specifies the CPU pin used for serial data output. Pin\_name must specify a output pin otherwise an error message occurs.

`/I2CDATI=pin_name`

Specifies the CPU pin used for serial data input. Pin\_name must specify a input pin otherwise an error message occurs.

**Example:** `JTAGEL5 /I2C EEPROM.CFG /I2CCLK=PIO31 /I2CDAT=PIO30`

This example loads the file EEPROM.CFG to a serial EEPROM connected to the pins PIO31 and PIO30 of the AMD ÉlanSC520



## **2.6.Read an I<sup>2</sup>C-Device to file**

**Usage:** JTAGEL5 /I2C filename /L=hhhhh [optionlist]

The contents of a I<sup>2</sup>C-Device (i.e. a serial EEPROM) is read and written to a file. The option /LENGTH= must be specified.

### **Options:**

/DEVICE-BASE=hhhhh<sup>4</sup>

See function /PI2C (Chapter 2.5)

/OFFSET=hhhhh

Reading of the I<sup>2</sup>C-Device starts at an offset of hhhhh relative to the start address of the I<sup>2</sup>C-Device.

Default: /OFFSET=0

Abbreviation: /O=

/LENGTH=hhhhh

The number of read bytes must be specified otherwise an error message occurs.

Abbreviation: /L=

/I2CCLK=pin\_name

See function /PI2C (Chapter 2.5)

/I2CDAT=pin\_name

See function /PI2C (Chapter 2.5)

/I2CDATO=pin\_name

See function /PI2C (Chapter 2.5)

/I2CDATI=pin\_name

See function /PI2C (Chapter 2.5)

<sup>4</sup>hhhhh=number base is hex

**Example:** JTAGEL5 /I2C EEPROM.CFG /I2CCLK=PIO31 /I2CDAT=PIO30  
/L=100

This example reads 256 bytes from a serial EEPROM to the file EEPROM.CFG. The serial EEPROM is connected to the pins PIO31 and PIO30 of the AMD ÉlanSC520.

## **2.7. Verify an I<sup>2</sup>C-Device with file**

**Usage:** JTAGEL5 /I2C filename [optionlist]

The contents of a I<sup>2</sup>C-Device (i.e. a serial EEPROM) is compared with the specified file. If there are differences the contents of the I<sup>2</sup>C-Device is written to a file with the extension DMP.

### **Options:**

/DEVICE-BASE= hhhhhh<sup>5</sup>

See function /PI2C (Chapter 2.5)

/OFFSET=hhhhhh

See function /PI2C (Chapter 2.5)

/FILE-OFFSET=hhhhhh

See function /PI2C (Chapter 2.5)

/LENGTH=hhhhhh

See function /PI2C (Chapter 2.5)

/NODUMP

See function /PI2C (Chapter 2.5)

/I2CCLK=pin\_name

See function /PI2C (Chapter 2.5)

/I2CDAT=pin\_name

See function /PI2C (Chapter 2.5)

/I2CDATO=pin\_name

See function /PI2C (Chapter 2.5)

/I2CDATI=pin\_name

See function /PI2C (Chapter 2.5)

<sup>5</sup>hhhhh=number base is hex

**Example:** JTAGEL5 /I2C EEPROM.CFG /I2CCLK=PIO31 /I2CDAT=PIO30

This example verifies 256 bytes from a serial EEPROM with the file EEPROM.CFG. The serial EEPROM is connected to the pins PIO31 and PIO30 of the AMD ÉlanSC520.

## **2.8.Dump an I<sup>2</sup>C-Device**

**Usage:** JTAGEL5 /DUMPI2C [optionlist]

A Hex-Dump of a I<sup>2</sup>C-Device is printed on the screen, if not redirected to file or device.

### **Options:**

/OFFSET=hhhhhh<sup>6</sup>

The memory dump starts at an offset of hhhhhh.

Default: /OFFSET=0

Abbreviation: /O=

/LENGTH=hhhhhh

Default: /LENGTH=100

Abbreviation: /L=

/I2CCLK=pin\_name

See function /PI2C (Chapter 2.5)

/I2CDAT=pin\_name

See function /PI2C (Chapter 2.5)

/I2CDATO=pin\_name

See function /PI2C (Chapter 2.5)

/I2CDATI=pin\_name

See function /PI2C (Chapter 2.5)

**Example:** JTAGEL5 /DUMPI2C /I2CCLK=PIO31 /I2CDAT=PIO30

This example makes a memory dump of the first 100h bytes of a serial EEPROM connected to the CPU.

<sup>6</sup>hhhhhh=number base is hex

## **2.9.Toggle CPU pins**

**Usage:** JTAGEL5 /BLINK /PIN=pinname [optionlist]

This command allows to test the hardware by blinking with LEDs or toggling CPU signals. Faster signals can be generated by setting the delay option to zero. This can be a very helpful feature to watch signals on an oscilloscope.

Please Note: Not every pin of the AMD ÉlanSC520 may be specified as an output pin.

### **Options:**

/PIN=pin\_name

CPU pin to toggle. If the option /PIN= is not specified an error message occurs. Most pins of the list in chapter 1.6 "Initialization file JTAGEL5.INI" can be used. If you type /PIN= without any pin declaration a list of the CPU pins is displayed.

/DELAY=dddddd<sup>7</sup>

Time to wait to next change of signal. This option can be adjusted to get optimum signals for measures with the oscilloscope.

Default: /DELAY=10000

**Example:** JTAGEL5 /BLINK /PIN=CS0# /DELAY=0

This example toggles the CS0# pin very fast which can be followed by the use of an oscilloscope.

<sup>7</sup>dddddd=number base is decimal

## **2.10. Polling CPU pins**

**Usage:** JTAGEL5 /PIN? /PIN=pinname [optionlist]

This command allows to test the hardware by polling CPU signals.

Please Note: Not every pin of the AMD ÉlanSC520 may be specified as an input pin.

### **Options:**

/PIN=pin\_name

CPU pin to poll. If the option /PIN= is not specified an error message occurs. Most pins of the list in chapter 1.6 “Initialization file JTAGEL5.INI” can be used. If you type /PIN= without any pin declaration a list of the CPU pins is displayed.

**Example:** JTAGEL5 /PIN? /PIN=PWRGOOD

This example samples the reset pin of the AMD ÉlanSC520.

## **2.11. Polling CPU pins while the CPU is running**

**Usage:** JTAGEL5 /SAMPLE /PIN=pinname [optionlist]

This command is similar to the function /PIN?. But with this function any pin can be observed, independent of the pin direction. Furthermore the CPU remains in normal operation.

### **Options:**

/PIN=pin\_name

CPU pin to poll. If the option /PIN= is not specified an error message occurs. All pins of the list in chapter 1.6 "Initialization file JTAGEL5.INI" can be used. If you type /PIN= without any pin declaration a list of the CPU pins is displayed.

**Example:** JTAGEL5 /SAMPLE /PIN=PITOUT2

This example samples the state of the port pin PITOUT2 (=signal for the speaker) while the AMD ÉlanSC520 is running.



## **2.12. List of supported Flash Devices**

**Usage:** JTAGEL5 /LIST [optionlist]

This command lists all supported flash devices to screen if not redirected to file or device. Flash devices signed with '\*' are not yet tested.

### **3. Implementation Information**

This chapter summarizes some information about the implementation of the JTAG-Booster and describes some restrictions.

- The JTAG-Booster currently uses the EXTEST function of the JTAG-Interface to perform Flash programming. The new debug interface of the AMD ÉlanSC520 is not used.
- The revision A0 and A1 of the AMD ÉlanSC520 have a silicon bug with the JTAG identification register. As a result of that bug, the contents of the identification register is shifted out infinitely. If there are other devices in the JTAG chain, the AMD ÉlanSC520 must be the first part in the chain (nearest to targets TDI). Otherwise the JTAG-Booster does not work.