

Device Selection Guide

Color	Parts Number	Typ. I_v (cd)	Test Current (mA)	Dice Technology
Orange	ASMT-FJ60-AFJ00	29	20	AllnGaP

Notes:

1. The luminous intensity I_v is measured at the peak of the spatial radiation pattern which may not be aligned with the mechanical axis of the LED package.
2. I_v Tolerance = $\pm 15\%$.

Absolute Maximum Ratings at $T_A = 25^\circ\text{C}$

Parameter	ASMT-FJ60-AFJ00	Units
DC Forward Current	70	mA
Power Dissipation	180	mW
LED Junction Temperature	110	$^\circ\text{C}$
Operating Temperature Range	-40 to 85	$^\circ\text{C}$
Storage Temperature Range	-40 to 85	$^\circ\text{C}$

Optical Characteristics at $T_A = 25^\circ\text{C}$

Part Number	Color	Peak Wavelength λ_{peak} (nm)	Dominant Wavelength λ_d [1] (nm)	Viewing Angle 2 $\theta_{1/2}$ [2] (Degrees)
		Typ.	Typ.	Typ.
ASMT-FJ60-AFJ00	Orange	612	605	10

Notes:

1. The dominant wavelength, λ_d , is derived from the CIE Chromaticity Diagram and represents the perceived color of the device.
2. $\theta_{1/2}$ is the off-axis angle where the luminous intensity is $1/2$ the peak intensity.

Electrical Characteristics at $T_A = 25^\circ\text{C}$

Color	Forward Voltage V_F (Volts) [1]			Reverse Breakdown, V_R (Volts) @ $I_R = 10\mu\text{A}$	
	Test Current	Min.	Typ.	Max.	Min.
Orange	20mA	1.8	2.1	2.6	5

Notes:

1. V_f tolerance : $\pm 0.1\text{V}$

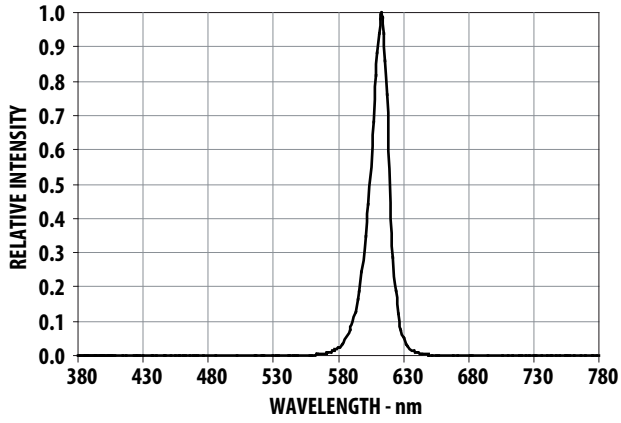

Figure 1. Relative Intensity vs. Wavelength

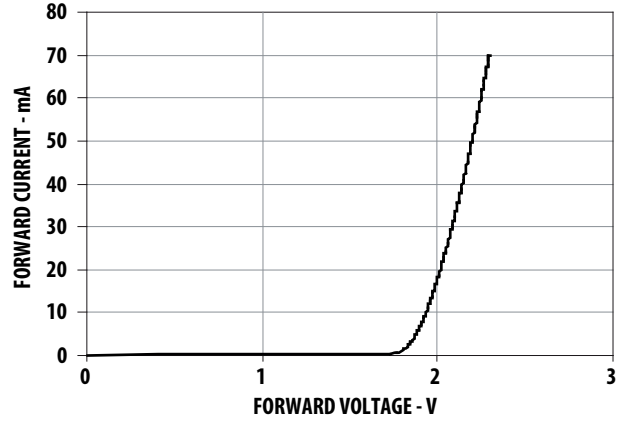

Figure 2. Forward Current vs Forward Voltage

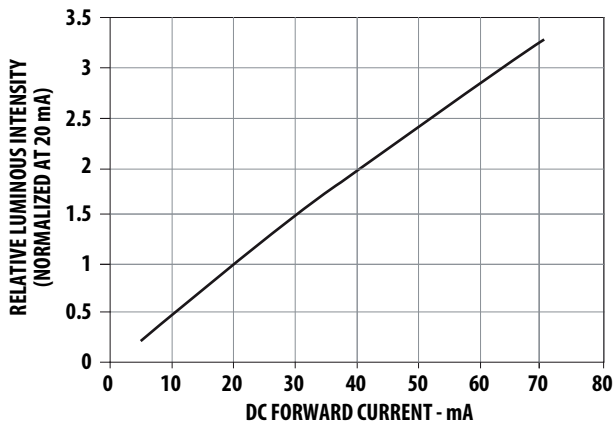

Figure 3. Relative Intensity vs. Forward Current

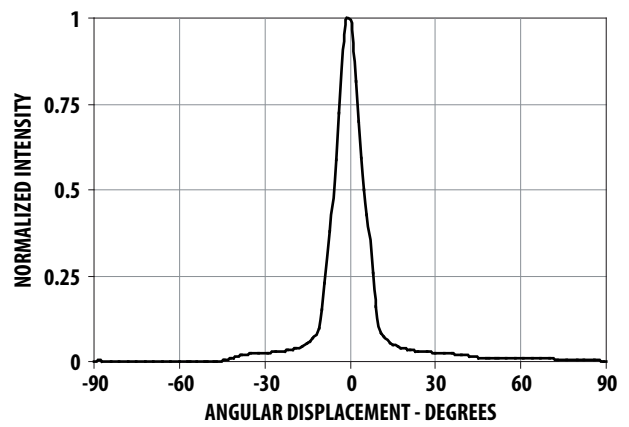

Figure 4. Radiation Pattern

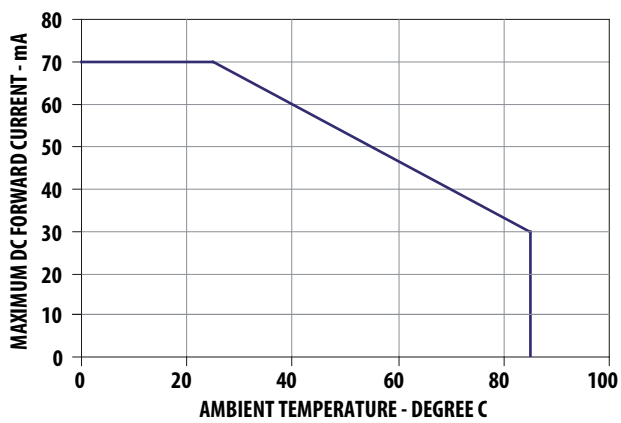

Figure 5. Maximum forward current vs ambient temperature.

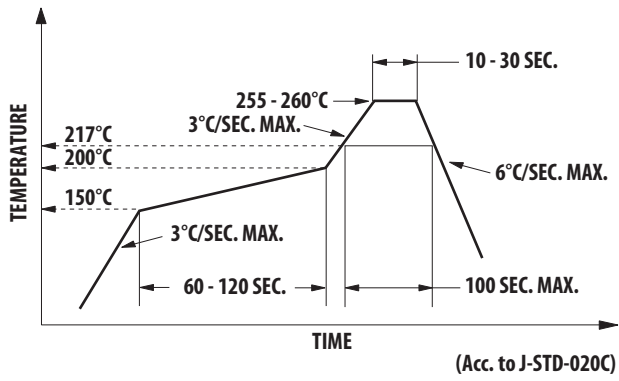

Figure 6. Recommended reflow soldering profile

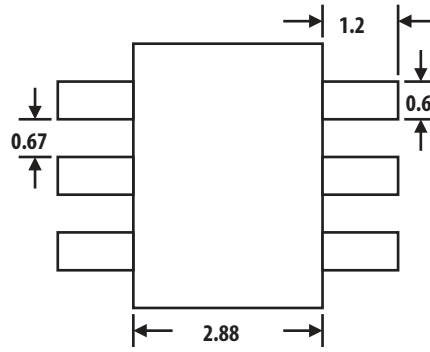

Figure 7. Recommended soldering land pattern

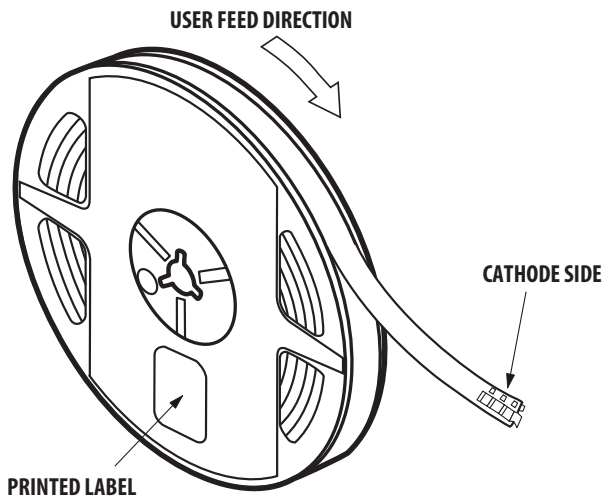

Figure 8. Reel Orientation

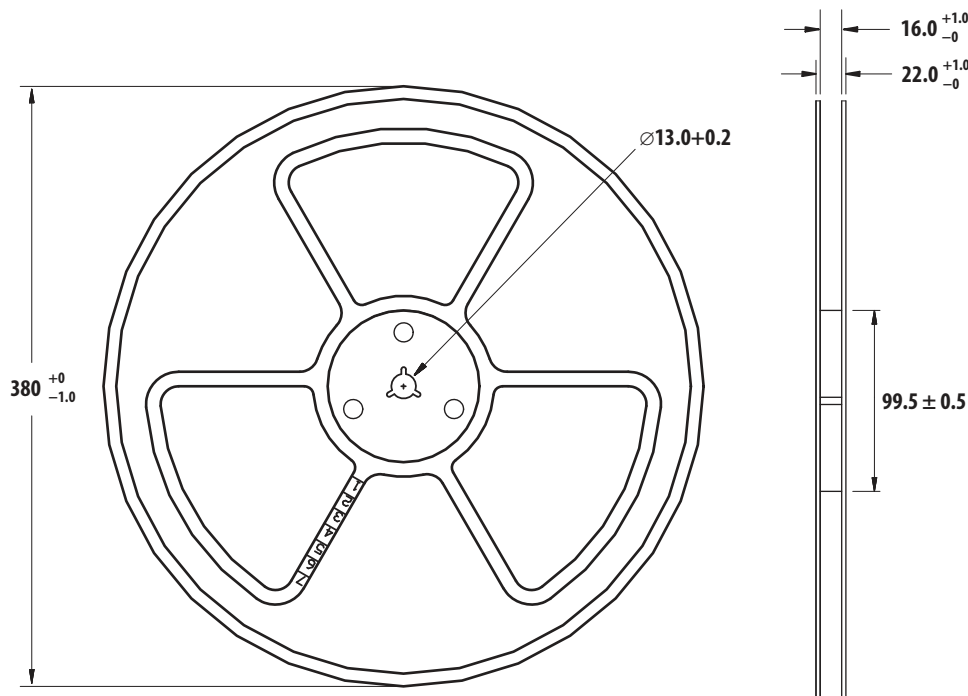

Figure 9. Reel Dimensions

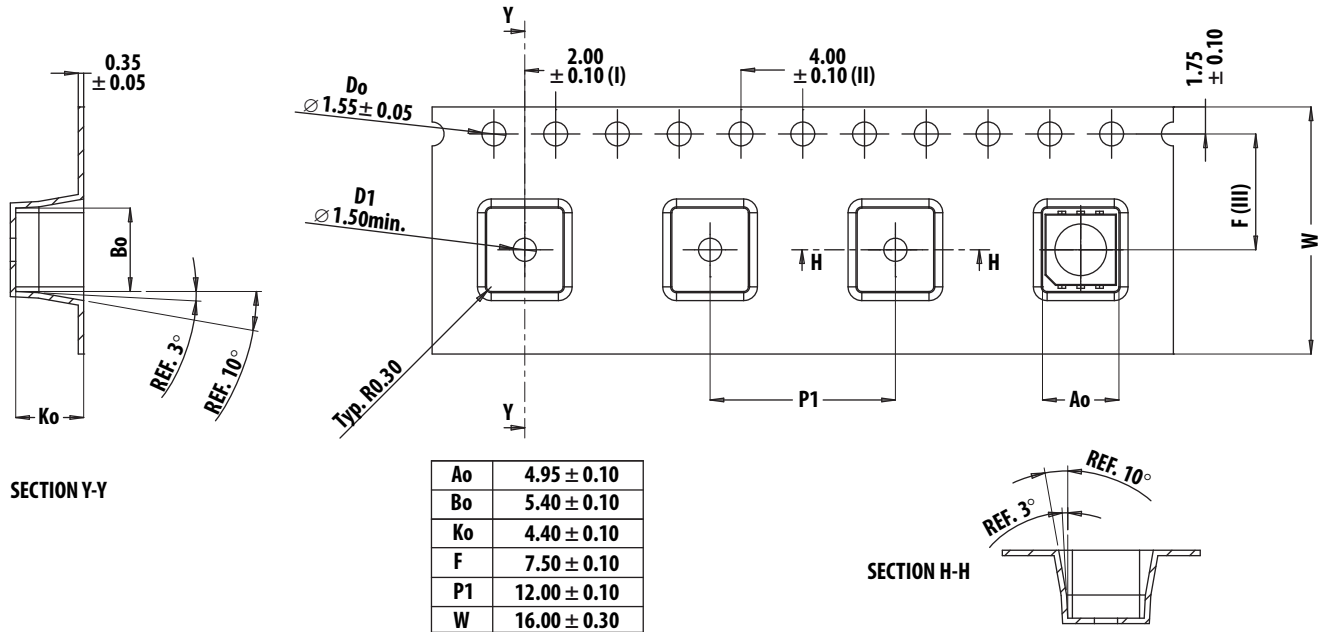

Figure 10. Tape Dimensions

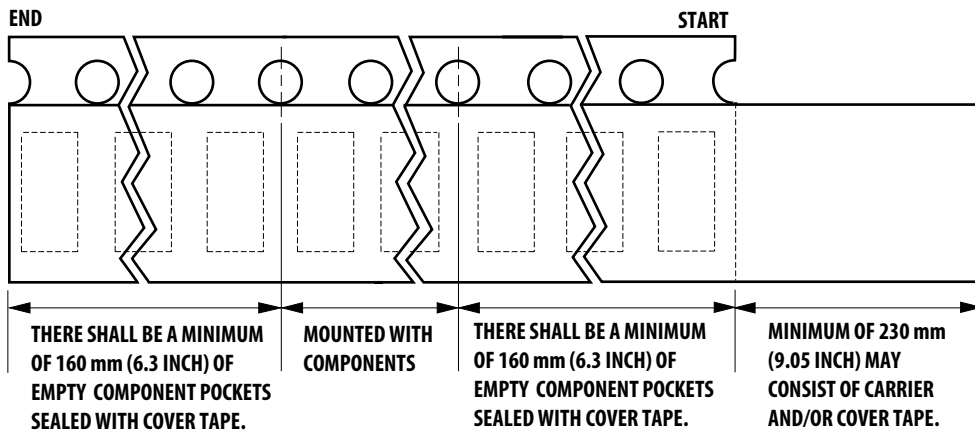

Figure 11. Tape Leader and Trailer Dimensions

Notes:

1. All dimensions in millimeters.
2. Tolerance is ± 0.1 mm unless otherwise specified

Iv Bin Category (cd)

Bin ID	Min	Max
F	15.0	19.5
G	19.5	25.5
H	25.5	33.0
I	33.0	43.0
J	43.0	56.0

Iv Tolerance = $\pm 15\%$

Color Bin Category

Orange

Orange	Min (nm)	Max (nm)
A	600	604
B	604	608
C	608	612

Tolerance = $\pm 1\text{nm}$

Handling Precaution

This products is classified as moisture sensitive level 3

When the bag is opened, parts required to mount within 168 hours of factory conditions $\leq 30^{\circ}\text{C}/60\%$, and stored at $<10\%$ RH.

Devices required bake, before mounting if:

- The humidity indicator card is $> 10\%$ when read at $23\pm 5^{\circ}\text{C}$
- The pack has been opened for more than 168 hours.

Baking recommended condition: $60 \pm 5^{\circ}\text{C}$ for 20 hours.

Note:

- Do not stack the units after reflow.

DISCLAIMER: Avago's products and software are not specifically designed, manufactured or authorized for sale as parts, components or assemblies for the planning, construction, maintenance or direct operation of a nuclear facility or for use in medical devices or applications. Customer is solely responsible, and waives all rights to make claims against avago or its suppliers, for all loss, damage, expense or liability in connection with such use.

For product information and a complete list of distributors, please go to our web site: www.avagotech.com

Avago, Avago Technologies, and the A logo are trademarks of Avago Technologies in the United States and other countries. Data subject to change. Copyright © 2005-2010 Avago Technologies. All rights reserved. AV02-2348EN - December 8, 2010

AVAGO
TECHNOLOGIES