



EV6513L-J-00A

0.6A, 5.5V
Full H-bridge Motor Driver
Evaluation Board

The Future of Analog IC Technology®

DESCRIPTION

The EV6513L-J-00A is an evaluation board for the MP6513LGJ, is a full-H-bridge motor driver used for driving reversible motors, which can drive one dc motor or one winding of a stepper motor or other loads.

It operates from a supply voltage range of 2.5V to 5.5V and can deliver motor current up to 0.6A.

The input control signals for the MP6513LGJ are applied through the connector.

ELECTRICAL SPECIFICATIONS

Parameter	Symbol	Value	Units
Input Voltage	V _{CC}	2.5-5.5	V
Maximum Output Current	I _{OUT}	0.6	A

FEATURES

- Wide 2.5V to 5.5V Input Voltage Range
- 0.6A continuous driver current
- Full-H-bridge motor drive
- OCP, OVP, and OTP

APPLICATIONS

- Cameras
- Toys
- Consumer Products
- Medical Devices

All MPS parts are lead-free, halogen free, and adhere to the RoHS directive. For MPS green status, please visit MPS website under Quality Assurance. "MPS" and "The Future of Analog IC Technology" are Registered Trademarks of Monolithic Power Systems, Inc.

EV6513L-J-00A EVALUATION BOARD



(L x W x H) 6.35cm x 6.604cm x 1.8cm

Board Number	MPS IC Number
EV6513L-J-00A	MP6513LGJ

EVALUATION BOARD SCHEMATIC

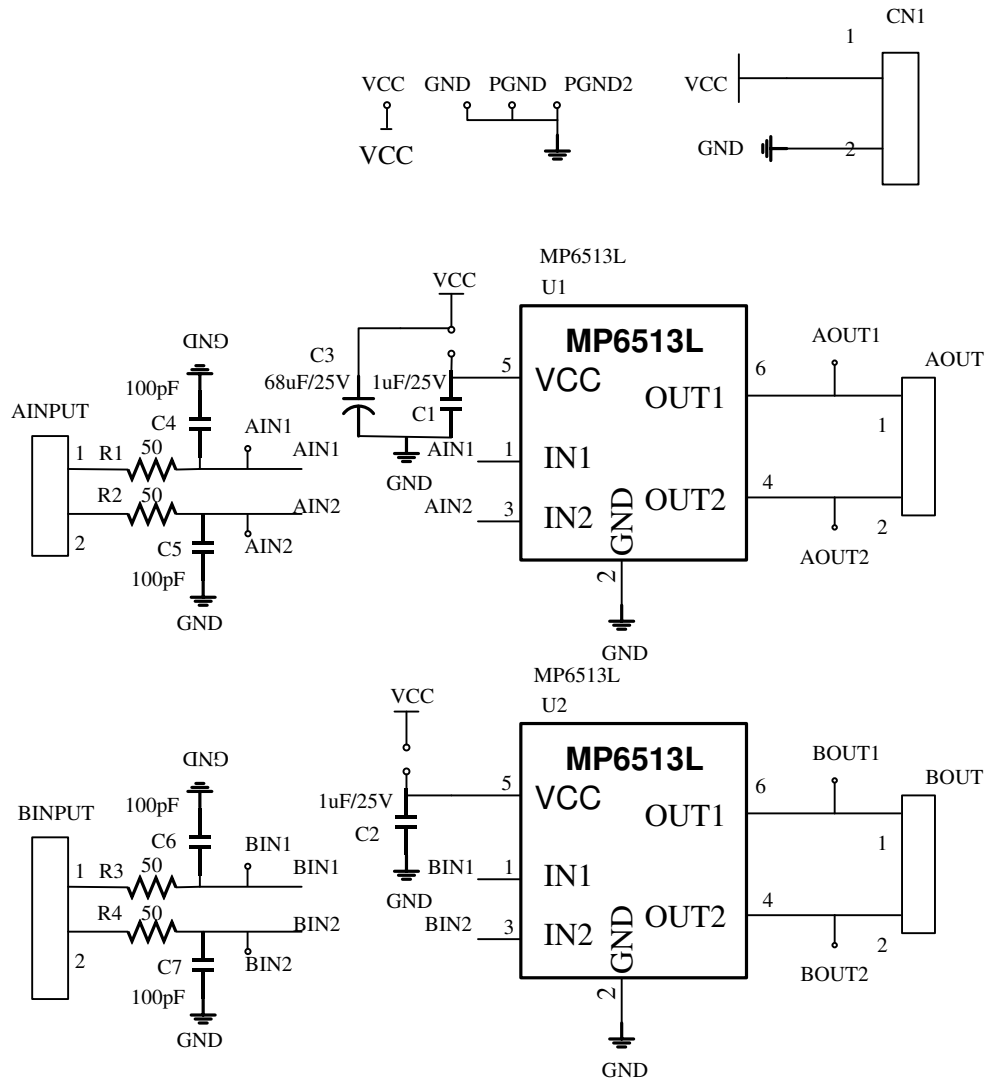
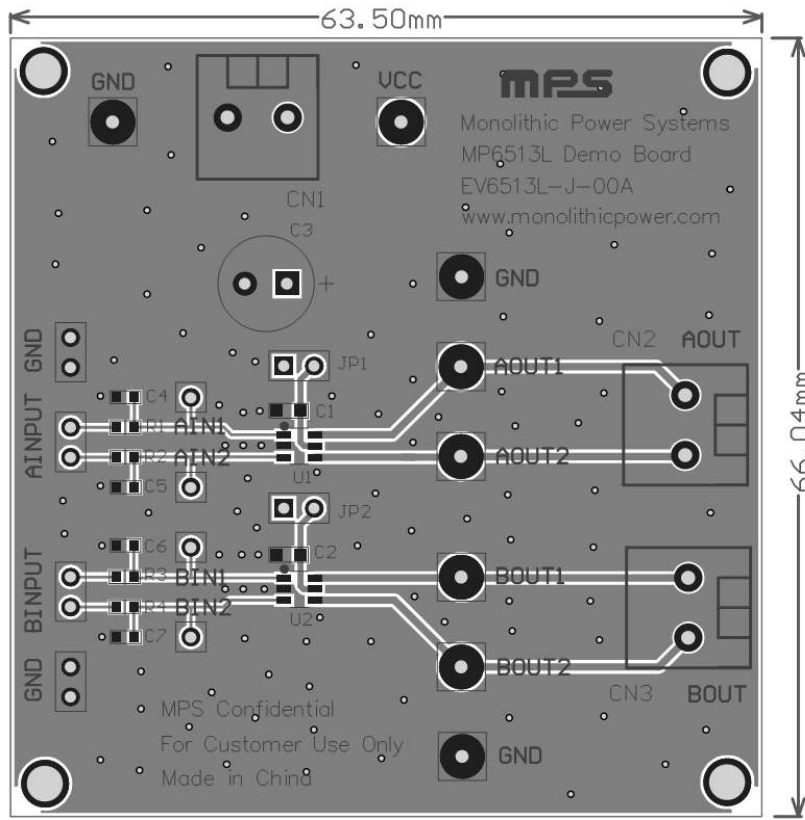

Figure 1 .Schematic of EVB

EV6513L-J-00A BILL OF MATERIALS

Qty	Ref	Value	Description	Package	Manufacturer	Part Number
2	C1,C2	1 μ F/25V	Ceramic Capacitor; 25V;X7R	0805	muRata	GRM21BR71E105KA99L
1	C3	68 μ F/25V	Ceramic Capacitor;50V	DIP	Panasonic	EEU-FCIH680
4	C4,C5,C6,C7	100pF	Ceramic Capacitor; 50V;C0G;	0603	muRata	GRM1885C1H101JA01D
4	R1, R2, R3,R4	49.9	Film Resistor;1%	0603	Yageo	RC0603FR-071KL
3	CN1, CN2, CN3		CONN/2PIN/5.08MM	DIP		
2	AINPUT, BINPUT,AIN1, AIN2, BIN1, BIN2, GND	CONNE CTOR	SIP 2.54mm * 40 PIN CONNECTOR	Radial	ANY	
2	JP1,JP2	CONNE CTOR	SIP 2.54mm * 40 PIN CONNECTOR	Radial	ANY	
8	AOUT1, BOUT1, AOUT2, BOUT2,GND* 3,VCC	TP	1mm GOLD PLATED TEST POINT	Radial	ANY	
2	U1,U2	MP6513L GJ	MP6513LGJ R6	FCTSOT23-6	MPS	MP6513LGJ

PRINTED CIRCUIT BOARD LAYOUT



QUICK START GUIDE

This board is set up from the factory for 2.5V to 5.5V operation.

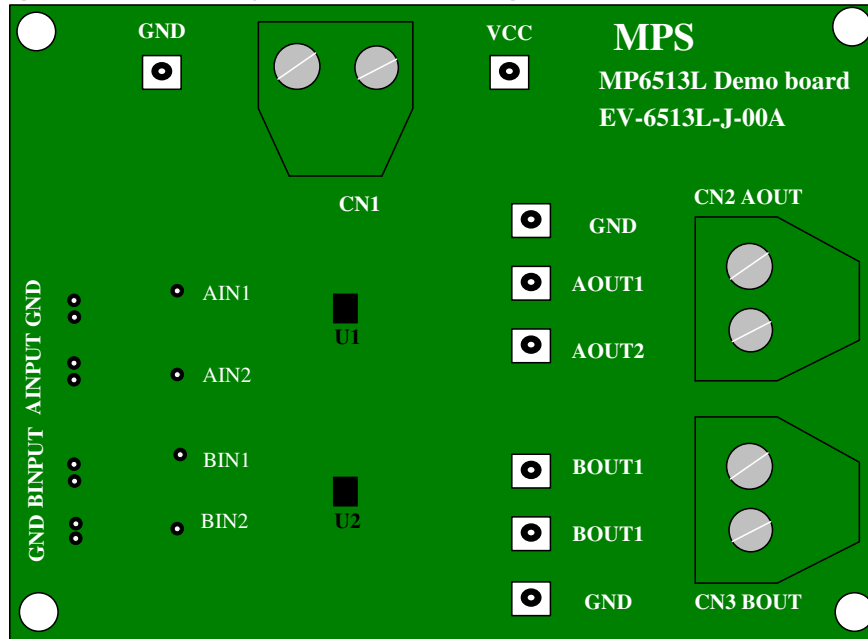

Figure 3. Input and Output Terminals of EV6513L-J-00A

1. Applications

This evaluation board can be used to control two single-phase DC motor independently or a stepper motor by corresponding input signals. The recommended supply voltage is range from 2.5V to 5.5V, and the maximum drive current is up to 0.6A for one channel.

2. Input logic

The MP6513L is controlled using a PWM input interface, each output is controlled by a corresponding input pin.

The following truth table shows the control logic for MP6513L:

IN1	IN2	OUT1	OUT2	Function (DC Motor)
L	L	Z	Z	Coast
L	H	L	H	Reverse
H	L	H	L	Forward
H	H	L	L	Brake

3. Setup Condition

- Preset power supply of 2.5V to 5.5V between VCC and GND pins on CN1 terminal.
- The connector AINPUT/BINPUT should be connected to input signals, and refer above table to find the corresponding control logic.
- The connector CN2/CN3 should be connected to the motor winding terminals. For a stepper motor, one winding should be connected to CN2(AOUT1/AOUT2), while the other should be connected to CN3(BOUT1/BOUT2).
- Turn on power supply.

NOTICE: The information in this document is subject to change without notice. Users should warrant and guarantee that third party Intellectual Property rights are not infringed upon when integrating MPS products into any application. MPS will not assume any legal responsibility for any said applications.