



50 to 100 Watts

Features & Benefits

- Inputs:
 - 28V_{DC} per MIL-STD-704D/E/F
 - 155V_{DC} per MIL-STD-1399A
 - 270V_{DC} per MIL-STD-704D/E/F
- Single output: 2 – 48V_{DC}
- Up to 23W/in³
- MIL-STD-810 environments
- Up to 90% efficiency
- Remote sense
- Current limit
- OVP and thermal shut down
- Power boosters for higher power outputs
- ZCS power architecture
- Low-noise FM control
- Size: 4.6 x 2.4 x 0.5in [116,8 x 61,0 x 12,7mm]

Product Highlights

The MI-200 family of DC-DC converters is designed for applications utilizing distributed power architectures. Based on Vicor VI-200 / VI-J00 family of zero-current switching, component level DC-DC converters, the MI-200 family offers exceptional performance in terms of power density, efficiency, noise, ease of use and reliability.

Fully encapsulated in Vicor industry-standard package, the MI-Series meets MIL-STD-810 environmental requirements for humidity, fungus, salt-fog, explosive atmosphere, acceleration, vibration and shock.

Standard features, such as wide output trimming/programming, current limiting, remote sense, output inhibit, and latching OVP and OTP combine to offer the highest degree of protection, versatility and reliability for power systems.

Packaging Options

Standard: Slotted baseplate

SlimMod: Flangeless baseplate, option suffix: - S

Example: MI - 2XX - XX - S

FinMod: Finned heat sink, option suffix:

- F1, -F2, -F3 and - F4

Examples:

MI - 2XX - XX -F1, 0.25in fins, longitudinal

MI - 2XX - XX -F2, 0.50in fins, longitudinal

MI - 2XX - XX -F3, 0.25in fins, transverse

MI - 2XX - XX -F4, 0.50in fins, transverse

Converter Selection Chart

MI-2

Semi-custom modules available, consult factory.

Input Voltage

Nominal	Range	Transient ^[a]	Notes
2 = 28V	18 – 50V ^[b]	60V	28V _{DC} input per MIL-STD 704D/E/F
5 = 155V	100 – 210V	230V	155V _{DC} input per MIL-STD-1399A
6 = 270V	125 – 400V ^[c]	475V	270V _{DC} input per MIL-STD-704D/E/F
7 = 165V	100 – 310V	n/a	

^[a] Transient voltage for 1 second.

^[b] 16V operation at 75% load.

^[c] MI-26Z-xV, MI-26Y-xV rated at 75% load from 125 – 150V_{IN}

Output Voltage

Z = 2.0V	1 = 12V
Y = 3.3V	P = 13.8V
0 = 5.0V	2 = 15V
X = 5.2V	N = 18.5V
W = 5.5V	3 = 24V
V = 5.8V	L = 28V
T = 6.5V ^[d]	J = 36V
R = 7.5V ^[d]	K = 40V
M = 10V	4 = 48V

^[d] 75W max power for 28V input

Product Grade Temperature (°C)

Operating	Storage
I = -40 to +85	I = -55 to +100
M = -55 to +85	M = -65 to +100
Overtemperature shut down 95°C typical (recycle power to restart)	

Output Power/Current V_{OUT}

≥5V	<5V
Y = 50W	Y = 10A
X = 75W	X = 15A
W = 100W	W = 20A
V = —	V = 30A
For additional output power, 100W and 75W booster modules available Change (MI-2xx-xx) to (MI-Bxx-xx)	

Converter Specifications

(Typical at $T_{BP} = 25^{\circ}\text{C}$, nominal line and 75% load, unless otherwise specified)

Input Specifications

Parameter	Min	Typ	Max	Units	Test Conditions
Inrush charge		120×10^{-6}	200×10^{-6}	Coulombs	Nominal line
Input reflected ripple current – pp		10%		I_{IN}	Nominal line, full load
Input ripple rejection		$30 + 20 \text{ Log} \left(\frac{V_{IN}}{V_{OUT}} \right)$		dB	120Hz, nominal line
		$20 + 20 \text{ Log} \left(\frac{V_{IN}}{V_{OUT}} \right)$		dB	2400Hz, nominal line
No load power dissipation		1.35	2	Watts	

Output Characteristics

Parameter	Min	Typ	Max	Units	Test Conditions
Setpoint accuracy		0.5%	1%	V_{NOM}	
Load/line regulation		0.05%	0.2%	V_{NOM}	LL to HL, 10% to Full Load
		0.2%	0.5%	V_{NOM}	LL to HL, No Load to 10%
Output temperature drift		0.01	0.02	% / $^{\circ}\text{C}$	Over rated temperature
Long term drift		0.02		%/1K hours	
Output ripple – pp		100	150	mV	Whichever is greater 20MHz bandwidth
		1.0%	1.5%	V_{NOM}	
Trim range ^[a]	50%		110%	V_{NOM}	
Total remote sense compensation	0.5			Volts	
OVP set point ^[b]	115%	125%	135%	V_{NOM}	latching
Current limit	105%		125%	I_{NOM}	Automatic restart
Short circuit current ^[c]	20%		130%	I_{NOM}	

^[a] 10V to 15V outputs, standard trim range $\pm 10\%$. Consult factory for wider trim range.
3.3V output trim range 2.20 to 3.63V

^[b] No over temperature or voltage protection in booster modules

^[c] Output voltages of 5V or less incorporate foldback current limiting; outputs of 10V and above provide constant current limiting.

Note: The permissible load current must never be exceeded during normal, abnormal or test conditions. For additional output related application information, please refer to output connections on page 5.

Control Pin Specifications

Parameter	Min	Typ	Max	Units	Test Conditions
Gate out impedance		50		Ohms	
Gate in impedance		1000		Ohms	
Gate in open circuit voltage		6		Volts	Use open collector
Gate in low threshold	0.65			Volts	
Gate in low current			6	mA	
Power sharing accuracy	0.95		1.05		

Converter Specifications (Cont.)

(Typical at $T_{BP} = 25^{\circ}\text{C}$, nominal line and 75% load, unless otherwise specified)

Dielectric Withstand Characteristics

Parameter	Min	Typ	Max	Units	Test Conditions
Input to output	3,000			V_{RMS}	Baseplate earthed
Output to baseplate	500			V_{RMS}	
Input to baseplate	1,500			V_{RMS}	
Input to output capacitance		50	75	pF	

Thermal Characteristics

Parameter	Min	Typ	Max	Units	Test Conditions
Efficiency		80 – 90%			
Baseplate to sink thermal impedance		0.07		$^{\circ}\text{C}/\text{Watt}$	With thermal pads
Thermal shutdown ^[d] (Drivers only)	90	95	105	$^{\circ}\text{C}$	Cool and recycle power to restart

^[d] No over temperature or voltage protection in booster modules

Environmental – MIL-STD-810D

Parameter	Min	Typ	Max	Units	Test Conditions
Altitude - method 500.2	70,000			feet	Procedure II
Humidity - method 507.2	86/240			%/hours	Procedure I, cycle 1
Acceleration - method 513.3	9			g	Procedure II
Vibration - method 514.3	20			g	Procedure I, category 6
Shock - method 516.3	40			g	Procedure I

Reliability – MIL-HDBK-217F (MI-22L-MW)

Parameter	Min	Typ	Max	Units	Test Conditions
25°C Ground Benign: G.B.		3,552		1,000 hours	
50°C Naval Sheltered: N.S.		639		1,000 hours	
65°C Airborne Inhabited Cargo: A.I.C.		501		1,000 hours	

Mechanical Specifications

Parameter	Min	Typ	Max	Units	Test Conditions
Weight	7.2 205	7.3 208	7.4 210	Ounces Grams	

Converter Specifications (Cont.)

Product Grade Specifications

Parameter	I-Grade	M-Grade
Storage temperature	-55°C to +100°C	-65°C to +100°C
Operating temperature (baseplate)	-40°C to +85°C	-55°C to +85°C
Power cycling burn-in	12 hours, 29 cycles	96 hours, 213 cycles
Temperature cycled with power off 17°C per minute rate of change	12 cycles -65°C to +100°C	12 cycles -65°C to +100°C
Test data supplied at these temperatures ^[e]	-40°C, +80°C	-55°C, +80°C
Warranty	2 years	2 years
Environmental compliance	MIL-STD-810	MIL-STD-810
Derating	NAVMAT P-4855-1A	NAVMAT P-4855-1A

^[e] Test data available for review or download from vicorpower.com

Maximum Capacitance, Rated Output Voltage <5V

Rated V_{OUT} (V)	I_{OUT} Rating (A)	C_{MAX} (μ F)	I_{OUT} Rating (A)	C_{MAX} (μ F)
2 to <3	≤ 10	1500	>10 to 40	5000
3 to <5	≤ 10	1000	>10 to 40	5000

Maximum Capacitance, Rated Output Voltage $\geq 5V$

Rated V_{OUT} (V)	P_{OUT} Rating (W)	C_{MAX} (μ F)	P_{OUT} Rating (W)	C_{MAX} (μ F)
5 to <7.5	≤ 50	1000	>50 to 100	1500
7.5 to <10	≤ 50	400	>50 to 100	700
10 to <28	≤ 50	400	>50 to 100	500
≥ 28	≤ 50	150	>50 to 100	250

Environmental Qualifications

Parameter	Qualification
Altitude	MIL-STD-810D, Method 500.2, Procedure III, explosive decompression (40K ft.).
	MIL-STD-810D, Method 500.2, Procedure II, 40,000ft., 1000 – 1500ft./min. to 70,000ft., unit functioning
Explosive Atmosphere	MIL-STD-810C, Method 511.1, Procedure I
Vibration	MIL-STD-810D, Method 514.3, Procedure I, category 6, helicopter, 20g
	MIL-STD-810D, Method 514.3 random: 10 – 300Hz @ 0.02g ² /Hz, 2000Hz @ 0.002g ² /Hz, 3.9 total Grms 3 hrs/axis. Sine: 30Hz @ 20g, 60Hz @ 10g, 90Hz @ 6.6g, 120Hz @ 5.0g, 16.0 total Grms, 3 axes
	MIL-STD-810E, Method 514.4, Table 514.4-VII, ± 6 db/octave, 7.7G rms, 1hr/axis
Shock	MIL-STD-810D, Method 516.3, Procedure I, functional shock, 40g
	MIL-STD-202F, Method 213B, 18 pulses, 60g, 9msec
	MIL-STD-202F, Method 213B, 75g, 11ms saw tooth shock
	MIL-STD-202F, Method 207A, 3 impacts / axis, 1, 3, 5 feet
Acceleration	MIL-STD-810D, Method 513.3, Procedure II Operational test, 9g for 1 minute along 3 mutually perpendicular axes
Humidity	MIL-STD-810D, Method 507.2, Procedure I, cycle I, 240 hrs, 88% relative humidity
Solder Test	MIL-STD-202, Method 208, 8hr. aging
Fungus	MIL-STD-810C, Method 508.1

Basic Module Operation

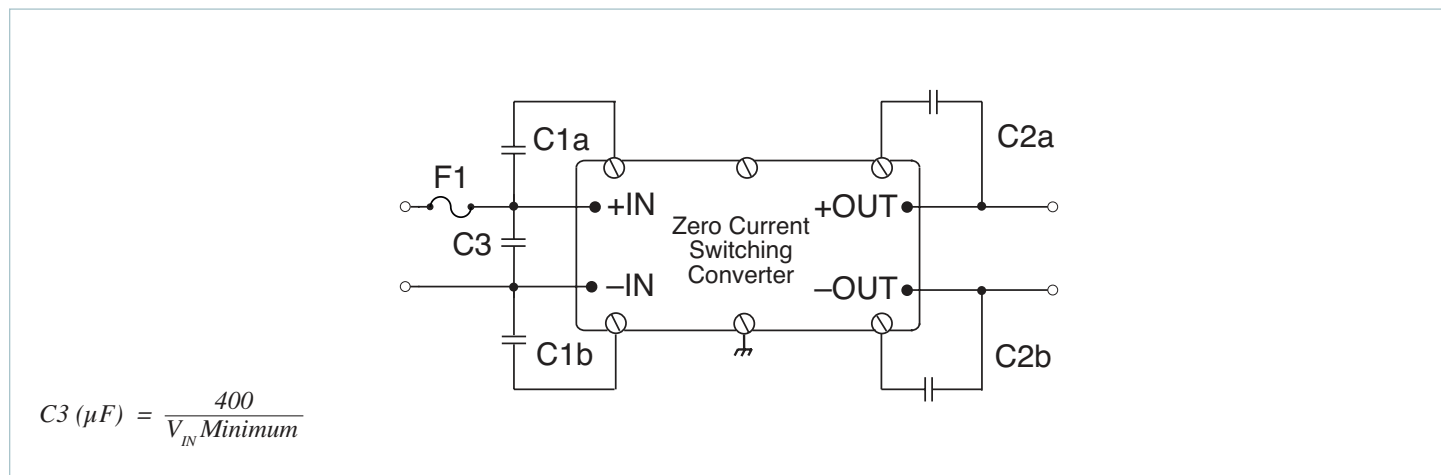

Figure 1 — Basic module operation requires fusing, grounding, bypassing capacitors.* See [Design Guide & Applications Manual](#).

Output Connections and Considerations

The permissible load current^[e] must never be exceeded during normal, abnormal or test conditions. Converters subject to dynamic loading exceeding 25% of rated current must be reviewed by Vicor Applications Engineering to ensure that the converter will operate properly.

Under dynamic load, light load, or no load conditions, the converter may emit audible noise. Converters that utilize remote sense may require compensation circuitry to offset the phase lag caused by the external output leads and load impedance. Remote Sense leads must be protected for conditions such as lead reversal, noise pickup, open circuit, or excessive output lead resistance between the sense point and the converters output terminals. For applications that may draw more than the rated current, a fast acting electronic circuit breaker must be utilized to protect the converter. Under no circumstance should the rated current be exceeded. Utilizing or testing of current limit or short circuit current will damage the converter. Ensure that the total output capacitance connected to the converter does not exceed the limits on Page 4.

^[e] Permissible load current: $\frac{\text{Nominal Power Rating}}{\text{Nominal } V_{OUT}}$

Storage

Vicor products, when not installed in customer units, should be stored in ESD safe packaging in accordance with ANSI/ESD S20.20, "Protection of Electrical and Electronic Parts, Assemblies and Equipment" and should be maintained in a temperature controlled factory/warehouse environment not exposed to outside elements controlled between the temperature ranges of 15°C and 38°C. Humidity shall not be condensing, no minimum humidity when stored in an ESD compliant package.

Mechanical Drawing

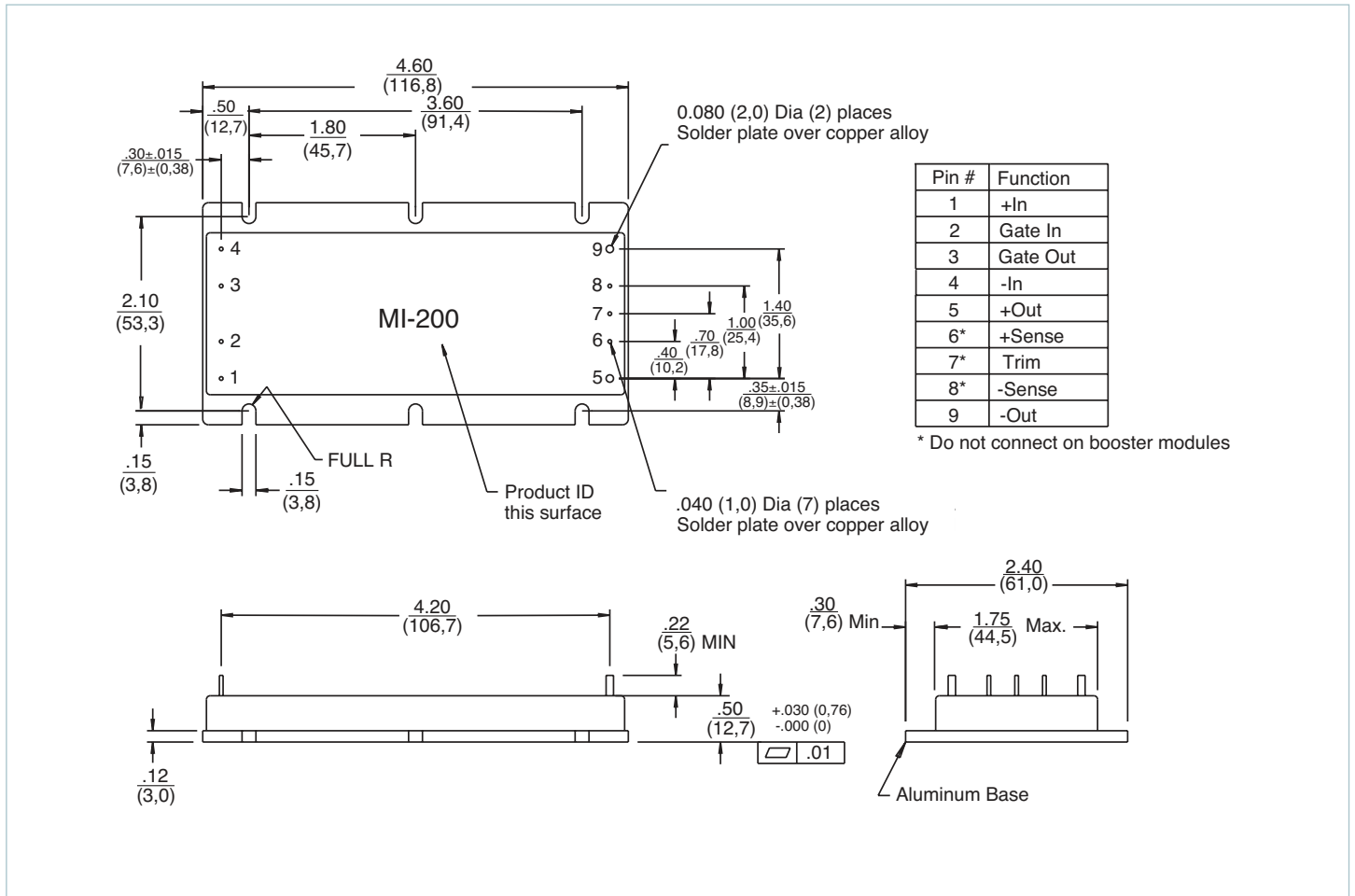

Note: For alternate package options refer to the mechanical drawing page of vicorpower.com

Vicor's comprehensive line of power solutions includes high density AC-DC and DC-DC modules and accessory components, fully configurable AC-DC and DC-DC power supplies, and complete custom power systems.

Information furnished by Vicor is believed to be accurate and reliable. However, no responsibility is assumed by Vicor for its use. Vicor makes no representations or warranties with respect to the accuracy or completeness of the contents of this publication. Vicor reserves the right to make changes to any products, specifications, and product descriptions at any time without notice. Information published by Vicor has been checked and is believed to be accurate at the time it was printed; however, Vicor assumes no responsibility for inaccuracies. Testing and other quality controls are used to the extent Vicor deems necessary to support Vicor's product warranty. Except where mandated by government requirements, testing of all parameters of each product is not necessarily performed.

Specifications are subject to change without notice.

Visit http://www.vicorpower.com/vi-200_vi-j00 for the latest product information.

Vicor's Standard Terms and Conditions and Product Warranty

All sales are subject to Vicor's Standard Terms and Conditions of Sale, and Product Warranty which are available on Vicor's webpage (<http://www.vicorpower.com/termsconditionswarranty>) or upon request.

Life Support Policy

VICOR'S PRODUCTS ARE NOT AUTHORIZED FOR USE AS CRITICAL COMPONENTS IN LIFE SUPPORT DEVICES OR SYSTEMS WITHOUT THE EXPRESS PRIOR WRITTEN APPROVAL OF THE CHIEF EXECUTIVE OFFICER AND GENERAL COUNSEL OF VICOR CORPORATION. As used herein, life support devices or systems are devices which (a) are intended for surgical implant into the body, or (b) support or sustain life and whose failure to perform when properly used in accordance with instructions for use provided in the labeling can be reasonably expected to result in a significant injury to the user. A critical component is any component in a life support device or system whose failure to perform can be reasonably expected to cause the failure of the life support device or system or to affect its safety or effectiveness. Per Vicor Terms and Conditions of Sale, the user of Vicor products and components in life support applications assumes all risks of such use and indemnifies Vicor against all liability and damages.

Intellectual Property Notice

Vicor and its subsidiaries own Intellectual Property (including issued U.S. and Foreign Patents and pending patent applications) relating to the products described in this data sheet. No license, whether express, implied, or arising by estoppel or otherwise, to any intellectual property rights is granted by this document. Interested parties should contact Vicor's Intellectual Property Department.

Contact Us: <http://www.vicorpower.com/contact-us>

Vicor Corporation
25 Frontage Road
Andover, MA, USA 01810
Tel: 800-735-6200
Fax: 978-475-6715
www.vicorpower.com

email

Customer Service: custserv@vicorpower.com
Technical Support: apps@vicorpower.com