

SECTION A-A
SCALE 1 : 8

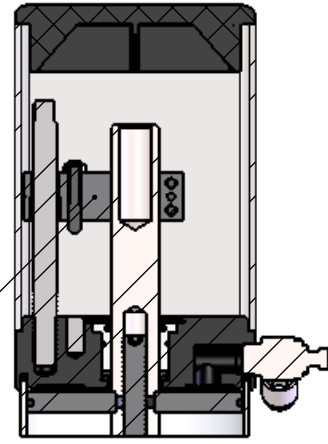

SECTION B-B
SCALE 1 : 4

ADJUSTABLE DOWNSTOP/
ANTI-ROTATE MECH.

EV-100 (VALVE AND REGULATOR ASSEMBLY)
STANDARD WITH MC-XXX ONLY

3 INCH STROKE CYLINDER STANDARD
(LONGER STROKES AVAILABLE)

ATTACHMENT BUTTON STANDARD
WITH ALL M-SERIES PRESSES

EC-100 (CONTROL BOX ASSEMBLY)
STANDARD WITH MC-XXX ONLY

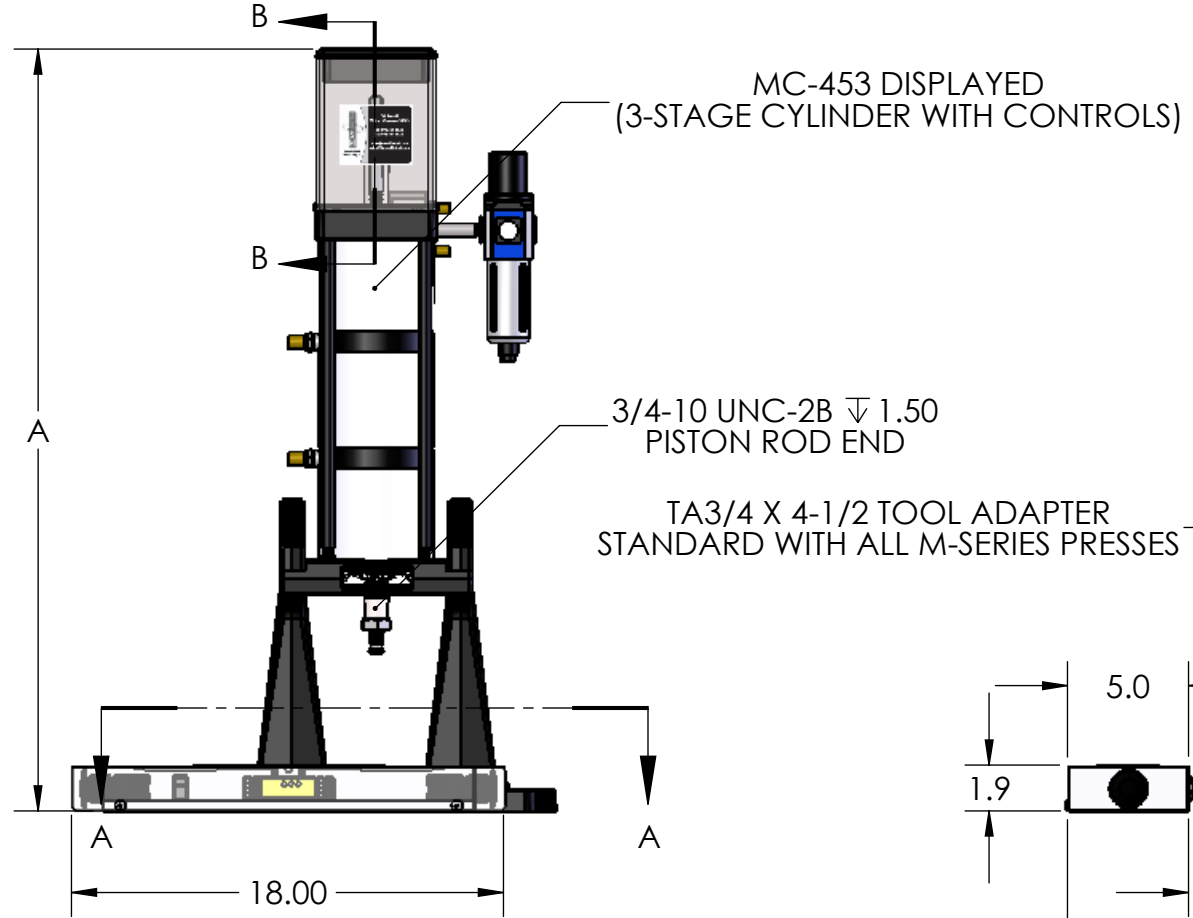
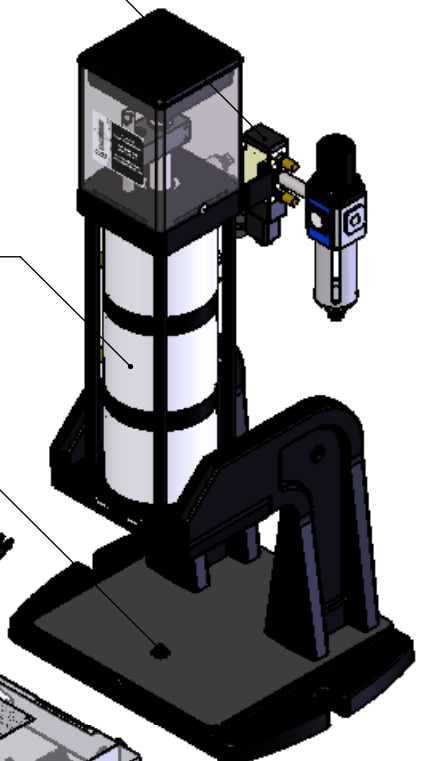

MC-453 DISPLAYED
(3-STAGE CYLINDER WITH CONTROLS)

3/4-10 UNC-2B 1.50
PISTON ROD END

TA3/4 X 4-1/2 TOOL ADAPTER
STANDARD WITH ALL M-SERIES PRESSES

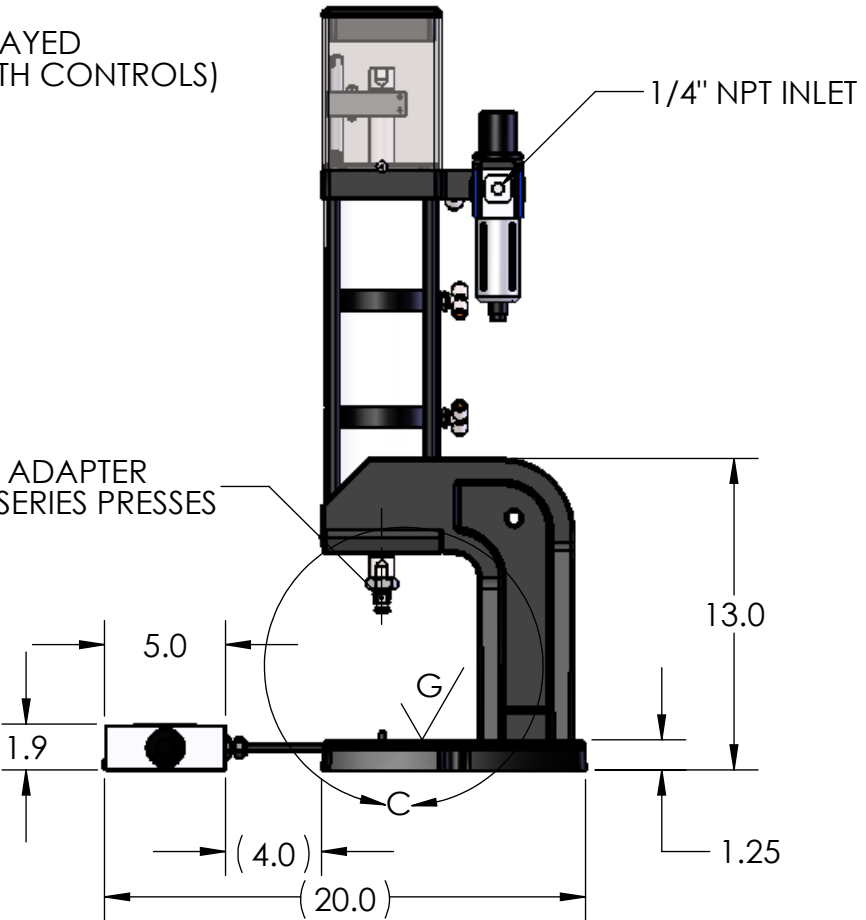

1/4" NPT INLET

Ø 1.0000
PISTON ROD

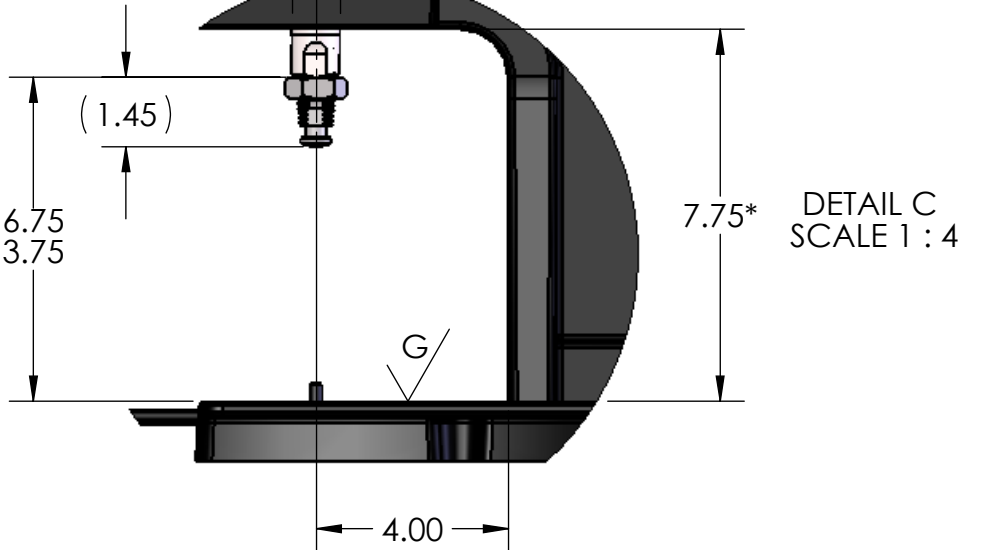

DETAIL C
SCALE 1 : 4

NOTES:

1. MC-XXX SERIES ARE COMPATIBLE WITH #1MDS-A~#7MDS-A DIE SETS
2. *THROAT HEIGHT CAN BE INCREASED WITH OPTIONAL RISER BLOCK KIT
3. PARTS SUBJECT TO CHANGE WITHOUT NOTICE

MODEL #	FORCE @ 80 PSI	WEIGHT	DIM. A
MC-151	1208	118 LBS	22.1
MC-302	2416	125 LBS	26.9
MC-453	3624	151 LBS	31.8

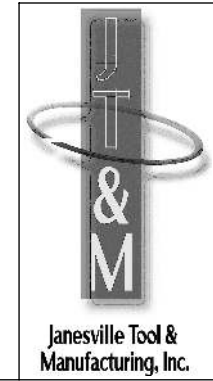

Janesville Tool & Manufacturing Inc.
3930 Enterprise Drive
Janesville, WI 53546
Phone: 608-314-1620, Fax: 608-314-1625

TITLE: PNEUMATIC PRESS		
SIZE B	DWG. NO. M SERIES	REV A
SCALE: 1:12	WEIGHT: N/A	SHEET 1 OF 1