

3M™ Water Filtration Products

SPEC# _____

QUANTITY _____

model:

application: **MULTIPLE EQUIPMENT**

DP260



3M™ Water Filtration Products, High Flow Series (DP2XX) model DP260 DUAL-PORT water filtration system helps provide consistent high-quality water for the multiple applications of cold beverages, ice and coffee at a combined flow rate of up to 6.68 gpm (25.3 lpm). Two separate streams exit the manifold. Both streams have reduced sediment and chlorine taste and odor. One stream has added scale-inhibition media from a dedicated cartridge to help reduce the ability of calcium and magnesium from adhering as hard scale on the evaporator plates of an ice machine and/or the heating coils of a coffee brewer. The other stream supplies cold beverage dispensers and includes no added scale inhibitor.

DP260 combines chlorine taste and odor reduction with cyst, bacteria and sediment reduction and helps provide protection from the effects of scale for total volumes up to 70,000 gallons (264,950 liters).

PRODUCT BENEFITS

- One system with dual outlet connections simultaneously supplies cold beverage dispensers and ice machines/coffee brewers.
- Up to 6.68 gpm (25.3 lpm) total flow of water especially treated for consistent great-tasting cold beverages, clear and consistent ice and the perfect cup of coffee or tea.
- Revolutionary **I**ntegrated **M**embrane **P**re-**A**ctivated **C**arbon **T**echnology (“**IMPACT**”) dual-zone media cartridge construction combines a membrane in series with premium activated carbon to provide superior throughput and cartridge life.
- Built-in bacteria inhibitor intended to reduce fouling of media (HF60 replacement cartridge only).
- Certified by NSF to Standard 53 for cyst reduction.
- NSF and/or FDA CFR-21 compliant materials.
- NSF certified (High Flow Series) 3M Purification Inc.
- Reduction of up to 99.99% of common water-borne heterotrophic bacteria by membrane filtration as tested by 3M Purification Inc. (HF60 replacement cartridge only).
- Reduction of scale build-up on evaporator plates and heating coils from the controlled forced-feed orifice addition of scale inhibitor, as tested by 3M Purification Inc.
- Sanitary Quick Change (SQC) encapsulated cartridge design allows for fast and easy cartridge change-outs with a 1/4 turn.
- 3/4" NPT horizontal inlet and outlet ports allow direct or easily adaptable connections to existing plumbing lines.
- Auxiliary inlet gauge port allows optional monitoring of differential water pressure.
- Manifold includes outlet check valves and vent valve.

PRODUCT SPECIFICATIONS

Model Number	Part Number	Reduction Claims	Nominal Micron Rating	Capacity	Service Flow Rate	Replacement Cartridge	Sizing
DP260	56255-01	Cysts ¹ , Bacteria ² , Sediment, Chlorine Taste and Odor, Scale	0.2	70,000 gallons (264,950 liters)	6.68 gpm (25.3 lpm)	DP260 CARTPAK 56138-14 (HF60 [Qty. 2] & CFS441)	For simultaneous operation of carbonators, coffee machines and ice machines

¹Includes oocysts of cryptosporidium and toxoplasma and cysts of giardia and entomoeba

²As tested with E. Coli ATCC (11229) and verified by manufacturer



DP260

3M™ Water Filtration Products

SPEC# _____
QUANTITY _____
MODEL NUMBER _____
PART NUMBER _____

SPECIFICATIONS

- System includes a two cartridge manifold with built-in pressure gauge, inlet water shut-off valve, outlet check valves, mounting brackets, two cartridge filters and a dedicated external scale inhibition cartridge.
- Auxiliary inlet gauge port allows optional monitoring of differential water pressure.
- Inlet and outlet plumbing connections are 3/4" NPT (choice of male or female is included).
- Filter cartridges are o-ring seal type.
- System maximum operating pressure of 125 psi (862 kPa) and operating temperature of 100°F (37.8°C).
- Recommended combined service flow rate is up to 6.68 gpm (25.3 lpm).
- Two large filter cartridges incorporate a bacteriostatic carbon block filtration medium (HF60 replacement cartridge only). Third cartridge includes a scale inhibition medium (HF8-S).
- System materials are NSF and/or FDA CFR-21 compliant.
- Cartridges are sanitary in design, requiring no contact with the filter media during cartridge change-out.
- Filter cartridges require no pre-activation.
- Shipping weight: Contact factory.
- Operating weight: 28.9 lbs. (13.1 kg).

IMPORTANT: INSTALLATION TIPS

These installation tips are for informational purposes only and are not intended to be used as actual installation instructions.

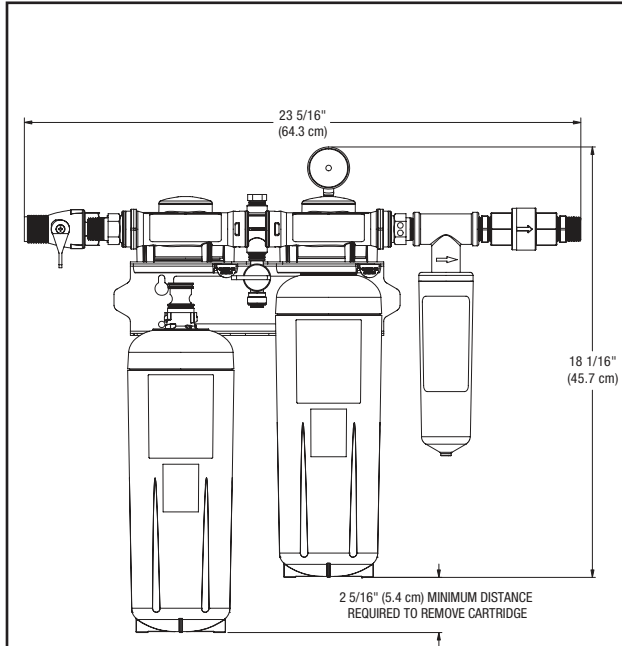

WARNING

To reduce the risk associated with ingestion of contaminants:

- Do not use with water that is microbiologically unsafe or of unknown quality without adequate disinfection before or after the system. Systems certified for cyst reduction may be used on disinfected water that may contain filterable cysts.

EPA Establishment #070595-CT-001

CAUTION

To reduce the risk associated with property damage due to water leakage:

- Read and follow Use Instructions before installation and use of this system.
- The disposable filter cartridge **MUST** be replaced every twelve (12) months, at the rated capacity or sooner if a noticeable reduction in flow rate occurs.

LIMITED WARRANTY & LIABILITY

3M Purification Inc. warrants this Product will be free from defects in material and manufacture for the period of five (5) years from the date of purchase: The filter cartridges or filter membranes are warranted to be free from defects in material and manufacture for one (1) year. This warranty does not cover failures resulting from abuse, misuse, alteration or damage not caused by 3M Purification Inc. or failure to follow installation and use instructions. No warranty is given as to the service life of any filter cartridge or membrane as it will vary with local water conditions and water consumption. **3M PURIFICATION INC. MAKES NO OTHER WARRANTIES OR CONDITIONS, EXPRESS OR IMPLIED, INCLUDING, BUT NOT LIMITED TO, ANY IMPLIED WARRANTY OR CONDITION OF MERCHANTABILITY OR FITNESS FOR A PARTICULAR PURPOSE OR ANY IMPLIED WARRANTY OR CONDITION ARISING OUT OF A COURSE OF DEALING, CUSTOMER OR USAGE OF TRADE.** If the Product fails to satisfy this Limited Warranty during the warranty period, 3M Purification Inc. will replace the Product or refund your Product purchase price. This warranty does not cover labor. **The remedy stated in this paragraph is Customer's sole remedy and 3M Purification Inc.'s exclusive obligation. For additional information, see the entire Limited Warranty located in the product Installation and Operating Instruction Manual.**

Limitation of Liability. 3M Purification Inc. will not be liable for any loss or damage arising from this 3M Purification Inc. product, whether direct, indirect, special, incidental, or consequential, regardless of the legal theory asserted, including warranty, contract, negligence or strict liability. Some states and countries do not allow the exclusion of limitation of incidental or consequential damages, so the above limitation or exclusion may not apply to you.



3M Purification Inc.
400 Research Parkway
Meriden, CT 06450, U.S.A.
Tel (888) 218-2866
(203) 237-5541
Fax (203) 238-8701
www.cunofoodservice.com
www.3Mpurification.com

Please recycle. Printed in U.S.A.
3M is a trademark of 3M Company.
NSF is a trademark of NSF International.
© 2010 3M Company. All rights reserved.
70-0202-6430-8 REV 0910