

PART NUMBER	REV	FIRST USED
680267-1	A	122500-1
680267-2	A	565435-5

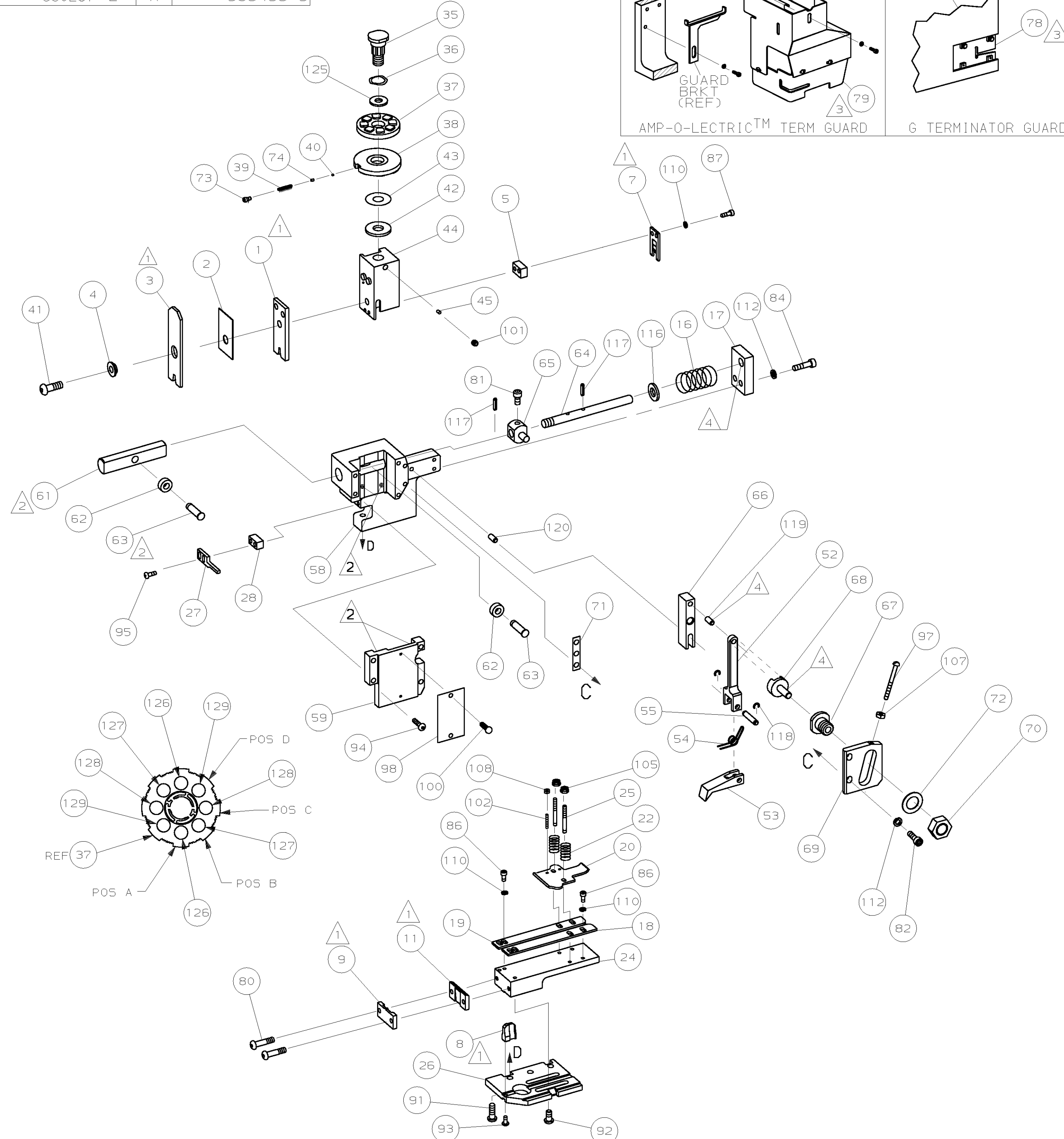
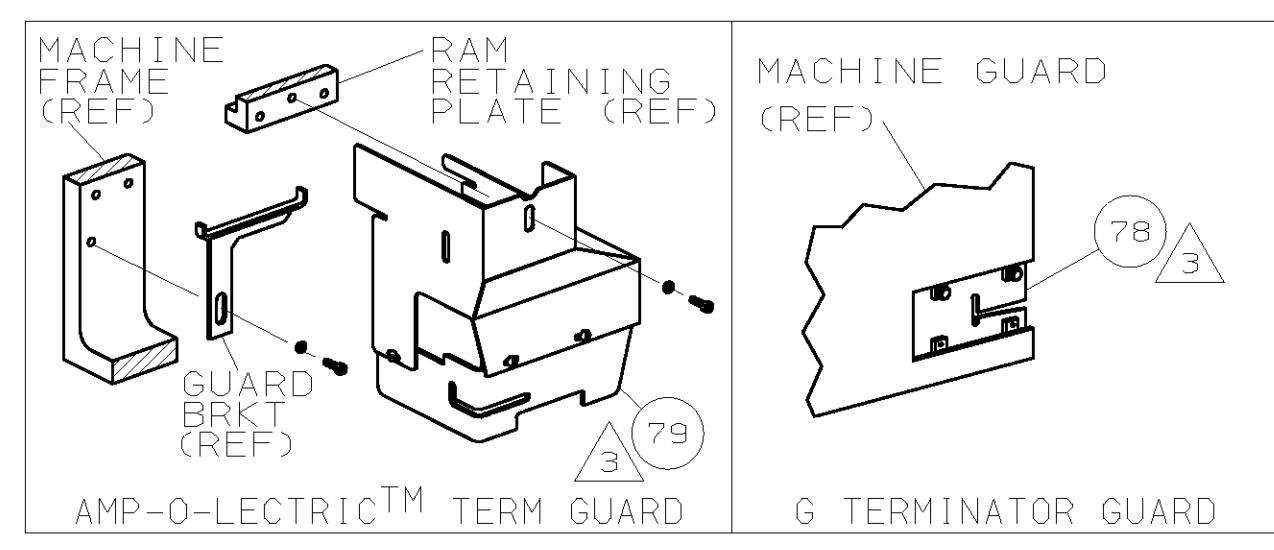

TERMINAL NAME: RING		CRIMPING DATA			
PAD LTR	CRIMP HEIGHT	WIRE SIZE			
A	.122 ±.002 [3.1 ±0.05mm]	4mm <sup>2</sup>			
B	.118 ±.002 [3.0 ±0.05mm]	(1)1mm <sup>2</sup> + (1)2.5mm <sup>2</sup>			
C	.109 ±.002 [2.77 ±0.05mm]	2.5mm <sup>2</sup>			
D	.104 ±.002 [2.64 ±0.05mm]	(1)1mm <sup>2</sup> + (1)0.5mm <sup>2</sup>			
CRIMP	SIZE	TYPE	RANGE		
WIRE	.160 [4.06mm]	F	2.5 - 4mm <sup>2</sup>		
INSUL	.210 [5.33mm]	F	-		
WIRE STRIP LENGTH	TERM APPL SPEC	FEED	APPL INSTRUCTION	SET UP GAGE	LAYOUT
-	NONE	1.136	408-8039	458638-1	L1737

LEADMAKER & BENCH MODEL G		MECH POST FEED				
BENCH MODEL K		MECH POST FEED				
REF	REF	-	A	22594-8	NUT, HEX	70
REF	REF	-	B	240628-1	PLATE, ADJ	69
REF	REF	-	B	240626-1	SHAFT, PIVOT	68
REF	REF	-	B	240633-1	BUSHING	67
REF	REF	-	A	455680-1	LEVER, INTERMEDIATE	66
REF	REF	-	B	240629-1	BLOCK, PIVOT	65
REF	REF	-	A	240632-2	SCR, ADJ	64
REF	REF	-	B	240659-3	PIN, CAM ROLLER	63
REF	REF	-	B	240658-1	CAM, ROLLER	62
REF	REF	-	B	454398-1	ROD, FEED	61

2	2	-	C	4-354778-3	PIN, WIRE DISC (.2710)D	129
2	2	-	C	3-354778-3	PIN, WIRE DISC (.2660)C	128
2	2	-	C	1-354778-5	PIN, WIRE DISC (.2570)B	127
2	2	-	C	354778-7	PIN, WIRE DISC (.2530)A	126
1	1	-	A	986950-1	WASHER, FLAT PRECISION	125
1	1	-	A	217238-1	DOCUMENTATION PACKAGE	124
1	1	-	-	4088039	EF APPL INST 408-8039	123
						122
						121
REF	REF	-	A	1-21030-7	PIN, DOWEL (Ø.187x1.50)H5G	120
REF	REF	-	A	1-21030-1	PIN, DOWEL (Ø.187x.50)LEVER	119
REF	REF	-	A	21045-3	RING, RET "C" (Ø.187)FD PIN	118
REF	REF	-	A	5-21028-1	PIN, STD SPRING (Ø.12)FD ADJ ROD	117
REF	REF	-	A	21899-4	WASHER, FLAT (Ø5/16)SCR ADJ	116
						115
						114
						113
REF	REF	-	A	21024-5	WASHER, LOCK (NO.10)FD ROD GDE	112
6	6	-	A	21024-4	WASHER, LOCK (NO.8)SHEAR BL	110
						109
2	2	-	A	21018-4	NUT, HEX (4-40)DRAG	108
REF	REF	-	A	21018-5	NUT, HEX (6-32)FD ADJ PL	107
						106
2	2	-	A	21022-2	NUT, HEX 5L (8-32)DRAG STUD	105
						104
						103
2	2	-	A	2-21006-6	SCR, SKT SET (4-40x.62)DRAG	102
1	1	-	A	21009-2	SCR, SKT SET (1/4-20x.25 )RAM	101
2	2	-	A	21017-2	SCR, DRIVE (#2x.19) ID PLATE	100
1	1	-	A	1-21002-7	SCR, BHC (6-32x.38)CAM	99
1	1	-	B	461264-1	PLATE, IDENTIFICATION	98
REF	REF	-	A	6-23715-5	SCR, PAN HD (6-32x1.50)FEED ADJ	97
						96
2	2	-	A	2-21002-2	SCR, BHC (8-32x.50)STRIPPER	95
REF	REF	-	A	2-21002-9	SCR, BHC (10-32x.75)H5G CAP	94
1	1	-	A	22733-8	SCR, BHC (8-32x.38 LW)ANVIL	93
4	4	-	A	3-21002-3	SCR, BHC (1/4-20x.50)ST 6D PL	92
REF	REF	-	A	2-22733-8	SCR, BHC (1/4-20x.62)BASE PL	91
						90
						89
						88
2	2	-	A	2-21000-9	SCR, 5HC (8-32x.75)SLUG BLADE	87
4	4	-	A	2-21000-6	SCR, 5HC (8-32x.38)STRIP GUIDE	86
						85
REF	REF	-	A	3-21000-7	SCR, 5HC (10-32x.75)FEED ROD GDE	84
						83
REF	REF	-	A	3-21000-6	SCR, 5HC (10-32x.62)FEED ADJ PL	82
REF	REF	-	A	3-21000-4	SCR, 5HC (10-32x.38)PIVOT BLOCK	81
2	2	-	A	3-21002-0	SCR, BHC (10-32x.88)SHEAR PL	80
REF	-	-	A	455745-1	GUARD, WINDOW	79
-	REF	-	A	679532-1	INSERT, GUARD	78
						77
						76
						75
1	1	-	A	690603-1	SPRING, ASSIST	74
1	1	-	A	23030-1	SCR, SKT CAP (6-32x.25)CP DSC	73
REF	REF	-	A	458109-1	WASHER, FLAT (SPECIAL)	72
REF	REF	-	A	690517-1	SPACER	71

						60
						59
						58
						57
						56
						55
REF	REF	-	B	240624-1	PIN, FEED FINGER	55
REF	REF	-	B	691499-1	SPRING, FEED FINGER	54
REF	REF	-	B	240635-1	FINGER, FEED	53
REF	REF	-	B	240634-1	LEVER, TERMINAL	52
						51
						50
						49
1	-	-	B	690501-3	CAM, POST FEED 1 1/8 ST	48
-	1	-	B	690501-4	CAM, POST-FEED 1 5/8 ST	47
						46
1	1	-	A	690191-1	PLUG, NYLON	45
1	1	-	C	455674-1	RAM	44
1	1	-	A	690125-1	WASHER, LAMINATED	43
1	1	-	A	1-690124-0	WASHER, RAM	42
1	1	-	A	7-21002-9	BOLT, CRIMPER (5/16-24x1.00)	41
1	1	-	A	23241-6	BALL, STEEL	40
1	1	-	A	690170-1	SPRING, COMPRESSION	39
1	1	-	C	690142-1	DISC, INSULATION	38
1	1	-	D	354777-1	WIRE DISC, PLASTIC	37
1	1	-	A	22480-5	WASHER, SPRING	36
1	1	-	B	690212-1	POST, RAM	35
						34
						33
1	1	-	D	458980-1	APPLICATOR, BASIC (SUB ASSY)	32
						31
						30
						29
1	1	-	B	3-690451-2	SPACER, STRIPPER	28
1	1	-	A	240639-1	STRIPPER	27
REF	REF	-	C	455676-1	PLATE, BASE	26
2	2	-	A	22354-8	DRAG, STUD	25
1	1	-	B	455678-1	PLATE, STRIP GUIDE	24
						23
2	2	-	A	4-22281-1	SPRING, DRAG	22
						21
1	1	-	A	454177-1	DRAG, STOCK	20
1	1	-	C	2-458030-2	GUIDE, STRIP (REAR)	19
1	1	-	C	2-458031-2	GUIDE, STRIP (FRONT)	18
REF	REF	-	A	454178-1	GUIDE, FEED ROD	17
REF	REF	-	A	4-22284-9	SPRING, FEED RETURN	16
						15
						14
						13
						12
1	1	-	B	240644-9	PLATE, REAR SHEAR	11
						10
1	1	-	B	690482-7	PLATE, FRONT SHEAR	9
1	1	-	D	356038-5	ANVIL	8
1	1	-	B	690474-7	BLADE, SLUG	7
						6
1	1	-	C	5-240641-3	SPACER, SLUG BLADE	5
1	1	-	B	238009-2	SPACER, BLOCK CRIMPER	4
1	1	-	C	3-683453-4	CRIMPER, INSULATION	3
1	1	-	B	455888-5	SPACER, CRIMPER	2
1	1	-	C	456414-5	CRIMPER, WIRE	1

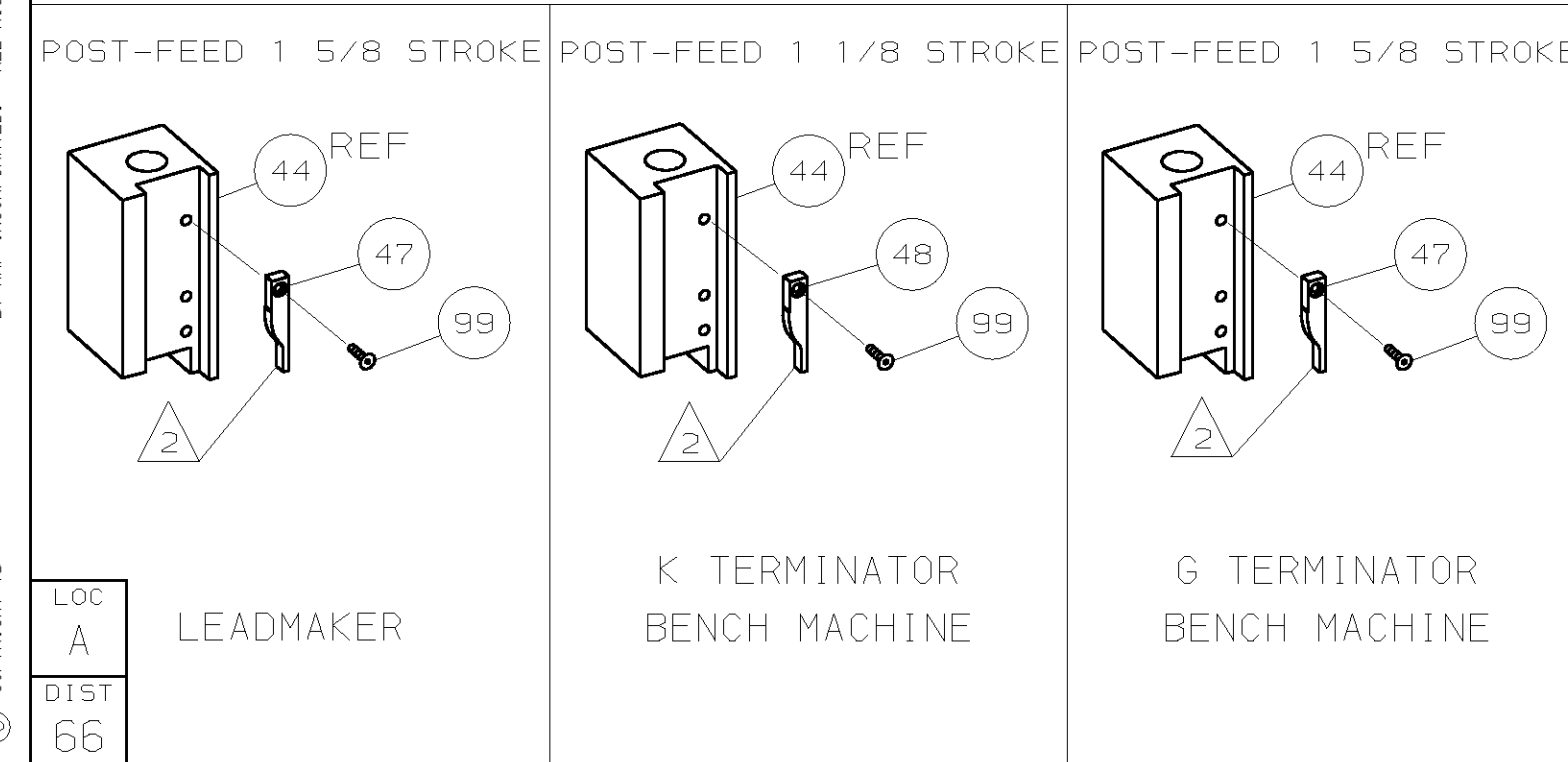

- 1 RECOMMENDED SPARE PARTS.
- 2 GREASE LIGHTLY.
- 3 GUARD MUST BE IN PLACE WHEN OPERATING APPLICATOR IN A BENCH MACHINE.
- 4 LUBRICATE DAILY USING NO. 20 MACHINE OIL.
- 5. ITEMS WITH QTY OF REF SPECIFIED (EXCEPT ITEMS 78 AND 79) ARE USED ON ITEM 32.
- 6 ITEM 78 USED WITH G TERMINATOR ONLY.

THIS DRAWING IS A CONTROLLED DOCUMENT.

THIS DRAWING IS UNRELEASED. RELEASE FOR PUBLICATION BY AMP INCORPORATED. ALL RIGHTS RESERVED. COPYRIGHT 19

LOC	LEADMAKER	K TERMINATOR BENCH MACHINE	G TERMINATOR BENCH MACHINE
A			
DIST			
66			

QTY	RECD	PER	ASSY	PARTS LIST	DESCRIPTION	ITEM NO
-2	-1	U/M	DWG SIZE	PART NO	DESCRIPTION	ITEM NO

QTY	RECD	PER	ASSY	PARTS LIST	DESCRIPTION	ITEM NO
-2	-1	U/M	DWG SIZE	PART NO	DESCRIPTION	ITEM NO

DIMENSIONS IN INCHES. DO NOT SCALE PRINT. TOLERANCES UNLESS OTHERWISE SPECIFIED:

DR B. HIGMAN 3/15/96 APP T. ELBIN 3/15/96  
 CHK C. ERISMAN 3/15/96 REL B. MORGAN 5/29/96

NAME: END FEED HDM APPLICATOR MACHINE REF: MINI APPL

SCALE: D DWG NO: 680267 SHEET: 1 OF 1 REV: A1

REMOVE BURRS, BREAK SHARP EDGES R.015 MAX

CUSTOMER AND ASSEMBLY DRAWING