

REV	REVISION	DATE
1	ISSUED	17/10/17

Panel cut out (front view)

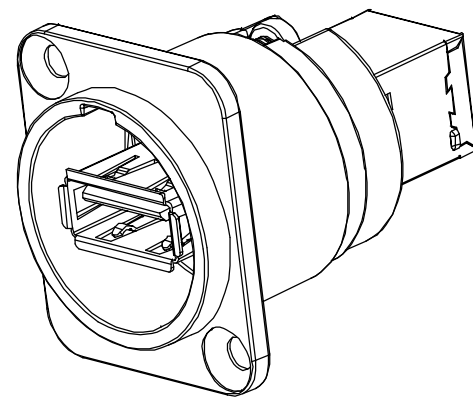
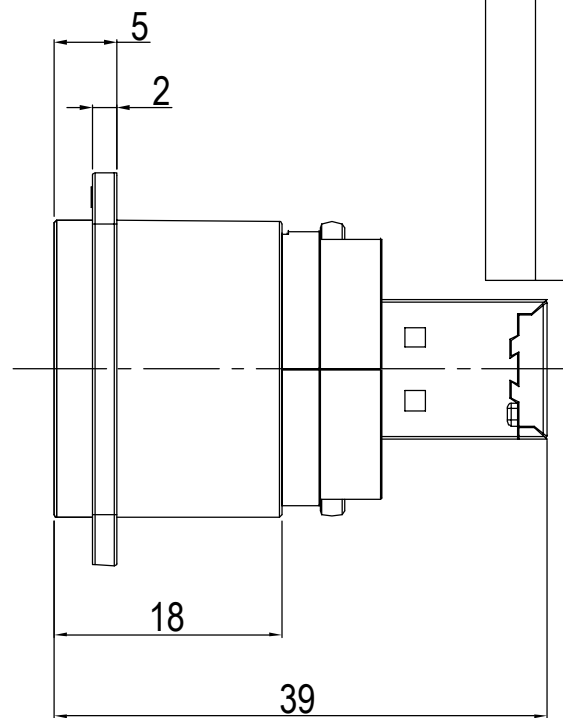
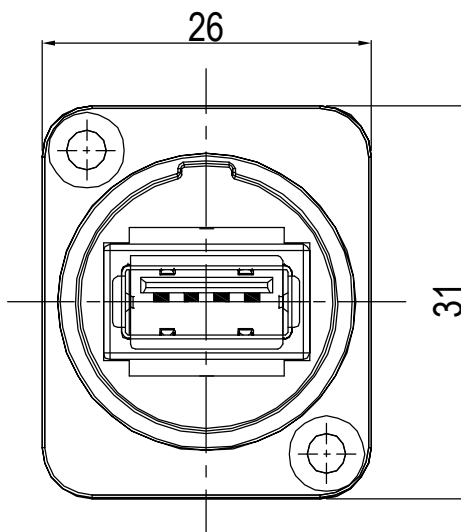
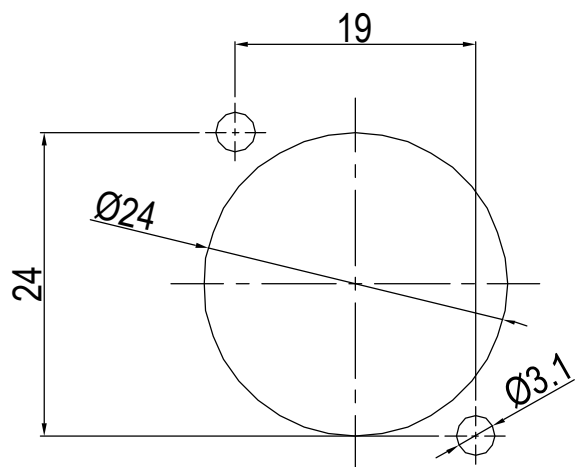

Specification + Technical Data:

Contact Resistance: 30mΩ MAX
 Insulation Resistance : 500MΩ min
 Dielectric withstanding voltage: 500V AC one minute
 Rated Current: 1.5A
 Rated Voltage: 30V
 Temperature Range: 0°C to +50°C
 (High-Speed): 25Mbps ~ 400Mbps (Max 480Mbps)
 (Full Speed): 500Kbps ~ 10Mbps (Max 12Mbps)
 (Low Speed): 10Kbps ~ 100Kbps (Max 1.5Mbps)

Plating

Contact : Touch Area Golden Plating 1μ"
 Soldering Area Tin Plating 40μ" min
 USB Shell: Nickel Plating 40μ" min

Contact	Standard A	Standard B
1	VBUS 4.75 - 5.25 VI	VBUS 4.4 - 5.25 VI
2	D-	D-
3	D+	D+
4	Earthing	Earthing

ITEM	DESCRIPTION	MATERIAL	FINISH
1	FRAME	ZINC DIECAST	NICKEL
2	FT INSERT	ABS	BLACK
3	SCREW	STEEL	NICKEL
4	USB2 A-B	PBT	WHITE
5	USB2 SHELL	BRASS	NICKEL
6	CONTACTS	BRASS	GOLD

Standard A

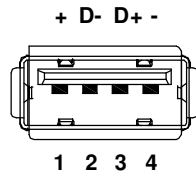

Standard B

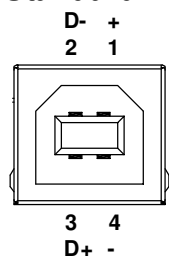

RoHS
COMPLIANT

TOLERANCE
 NO DEC. PLACE ±
 1 DEC. PLACE ±
 2 DEC. PLACE ±
 HOLE Ø ±
 ANGLES ±
 UNLESS OTHERWISE STATED

DO NOT SCALE

Cliff Electronic Components Ltd.

76 Holmehorpe Avenue, Holmehorpe Industrial Estate,
 Redhill, Surrey, RH1 2PF, England, UK
 Tel: 01737-771375 Fax: 01737-766012 Website: www.cliffuk.co.uk

THE CONTENTS OF THIS DOCUMENT MUST NOT BE COPIED OR DISCLOSED TO A 3rd PARTY WITHOUT WRITTEN PERMISSION OF CLIFF UK © 2017

DIMENSIONS IN MILLIMETERS UNLESS OTHERWISE STATED. WORK TO DIMENSIONS. REMOVE ALL BURRS. IF IN DOUBT ASK.

3rd ANGLE PROJECTION:



MATERIAL: SEE TABLE
 FINISH: SEE TABLE

TITLE: XLR USB2 A-B FT - METAL

DRAWN: T.J.O.

APPROVED: D.P.J.

DRWG. No. **CP30110**

FORM: A4DRWGH