

DO NOT SCALE FROM THIS PRINT

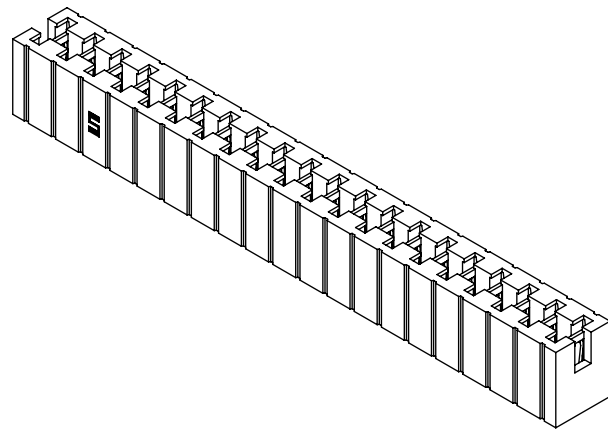

MNT-1XX-XX-X

No OF POSITION
-01 THRU -20

LEAD STYLE
SPECIFY COLOR IN BODY SUFFIX -XX
BK = BLACK

PLATING SPECIFICATION

-T: MATTE TIN
-G: 10µ" GOLD IN CONTACT AREA, MATTE TIN ON REMAINDER
-H: 30µ" GOLD IN CONTACT AREA, MATTE TIN REMAINDER

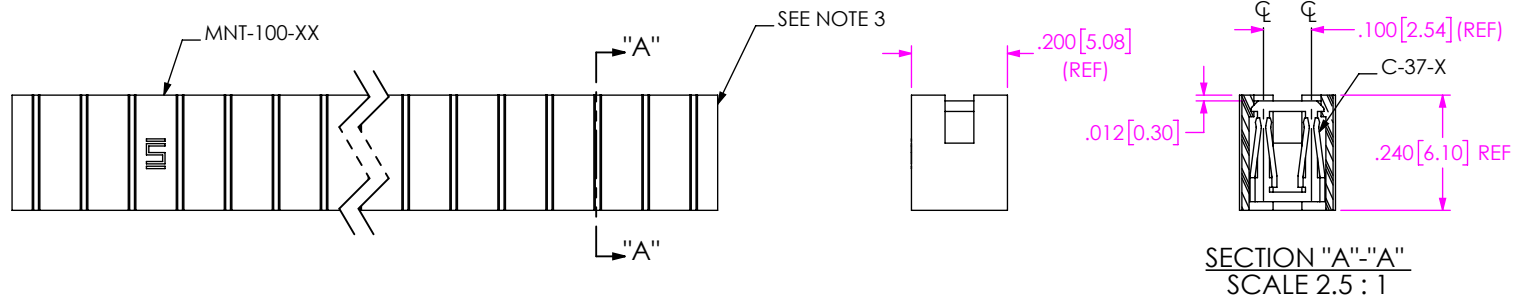
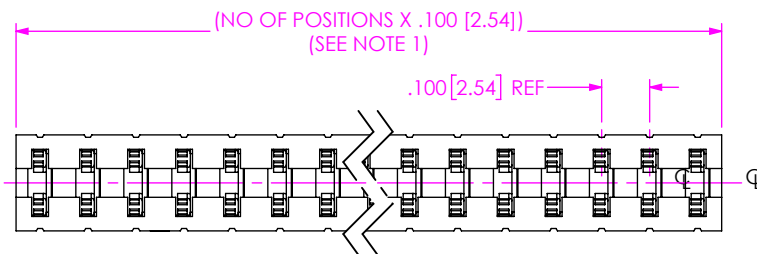

NOTES:

1. MULTI-CUT WIDTH TOLERANCED TO $\begin{matrix} +.005 [0.13] \\ -.015 [0.38] \end{matrix}$ REPRESENTS A CRITICAL DIMENSION.
ROTO-CUT WIDTH TOLERANCED TO $\pm .010 [0.25]$.
2. MINIMUM RETENTION: 24 oz
3. ENDWALL AFTER CUTTING $.0245 \pm .010 [.622 \pm .25]$
4. $.015 [0.38]$ MAXIMUM CUT FLASH. LOOSE CUT FLASH MUST BE REMOVED.

UNLESS OTHERWISE SPECIFIED, DIMENSIONS ARE IN INCHES.

TOLERANCES ARE:

DECIMALS ANGLES
.XX: $\pm .01 [.3]$ 2°
.XXX: $\pm .005 [.13]$
.XXXX: $\pm .0020 [.051]$

PROPRIETARY NOTE
* THIS DOCUMENT CONTAINS CONFIDENTIAL AND PROPRIETARY INFORMATION AND ALL DESIGN, MANUFACTURING, REPRODUCTION, USE, PATENT RIGHTS AND SALES RIGHTS ARE EXPRESSLY RESERVED BY SAMTEC, INC. THIS DOCUMENT SHALL NOT BE DISCLOSED, IN WHOLE OR PART, TO ANY UNAUTHORIZED PERSON OR ENTITY NOR REPRODUCED, TRANSFERRED OR INCORPORATED IN ANY OTHER PROJECT IN ANY MANNER WITHOUT THE EXPRESS WRITTEN CONSENT OF SAMTEC, INC.

DO NOT SCALE DRAWING SHEET SCALE: 3:1
INSULATOR: PBT, UL 94 V-O, COLOR BLACK
50% REGRIND
TERMINAL: BeCu, 1/2 HARD, AGE HARDENED
F:\DWG\MISC\MKTG\MNT-1XX-XX-X-MKT.SLDDRW

520 PARK EAST BLVD, NEW ALBANY, IN 47150 PHONE: 812-944-6733 FAX: 812-948-5047 e-Mail: info@SAMTEC.com code 53322	
DESCRIPTION:	.050 .050 EDGE MOUNT SOCKET STRIP DUAL ROW ASSEMBLY
DWG. NO.	MNT-1XX-XX-X
BY: KOLB	2-20-89 SHEET 1 OF 1