

IPBS-1XX-XX-XX-S-XX

No OF POSITIONS
-02 THRU -10
(PER ROW)

OPTION
-GP: GUIDE POSTS
(USE IPBS-XX-S-GP)
[SEE FIG. 3, SHT 2]

LEAD STYLE

- 01: STANDARD POWER, THROUGH HOLE
(USE C-168-01-SP-XX)(SEE FIG. 1)
- 02: STANDARD POWER, SURFACE MOUNT
(USE C-168-02-SP-XX)(SEE FIG. 2, SHEET 2)
- H1: HIGH POWER, THROUGH HOLE
(USE C-168-01-HP-XX)(SEE FIG. 1)(SEE NOTE 9)
- H2: HIGH POWER, SURFACE MOUNT
(USE C-168-02-HP-XX)(SEE FIG. 2, SHEET 2) (SEE NOTE 9)

ROW SPECIFICATION
-S: SINGLE (USE IPBS-XX-S)

PLATING SPECIFICATION
-T: TIN (USE C-168-XX-XX-T)
-TM: MATTE TIN (USE C-168-XX-XX-T)

DO NOT
SCALE FROM
THIS PRINT

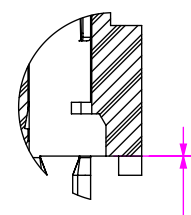
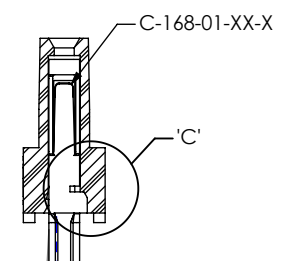
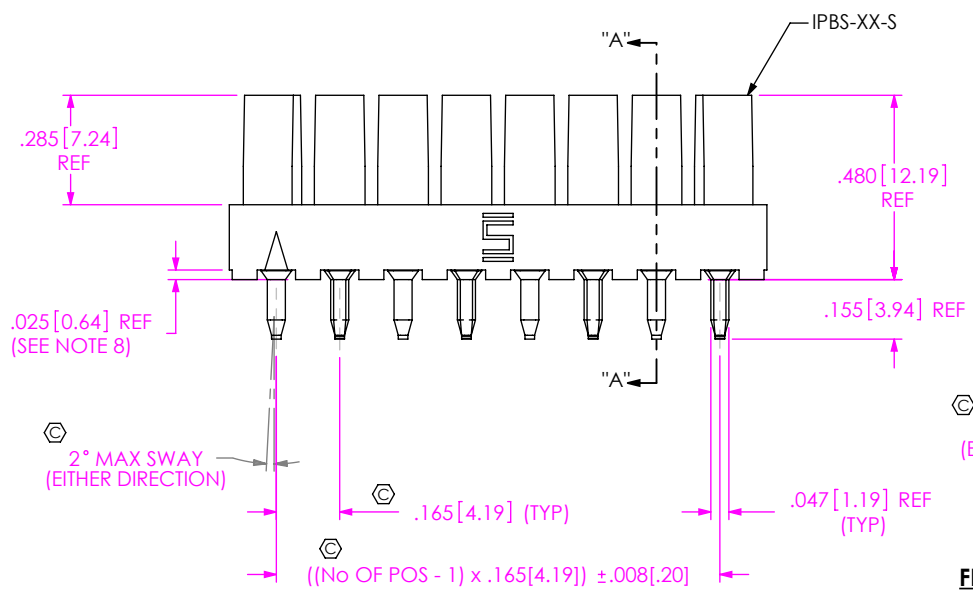
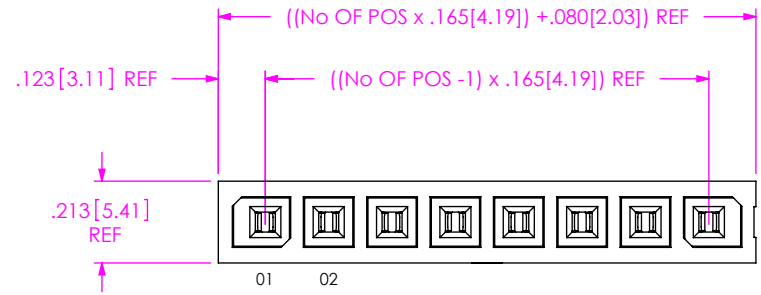

DETAIL 'C'
SCALE 4:1

FIG. 1

IPBS-108-X1-XX-S SHOWN

NOTES:

1. Ⓢ REPRESENTS A CRITICAL DIMENSION.
2. COPLANARITY (FOR -X2): SEE TABLE 1.
3. BURR ALLOWANCE: .003[.08] MAX.
4. PARTS TO BE MOLDED TO POSITION.
5. MINIMUM PUSHOUT FORCE: 1 LB[4.45 N].
6. MEASURED AT THE LOWEST POINT.
7. ALL PIN TO PIN DIMENSIONS TO BE MEASURED FROM TIP TO TIP.
8. TWO POSITION PART WILL HAVE STANDOFFS ON ENDS.
9. AVAILABLE TO EXISTING CUSTOMERS ONLY. DO NOT DESIGN IN AS OF REVISION D.

PACKAGING VIEWS

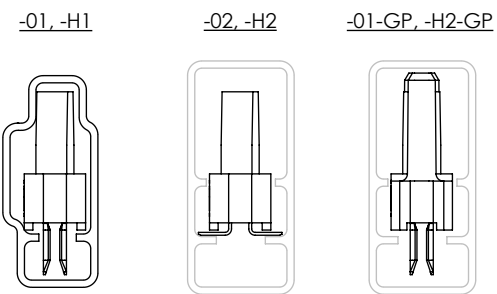

TABLE 2		
LEAD / OPTION	PACKAGING TUBE	PLUG
-X1-GP, X2, -X2-GP	PT-1-24-01-152	TP-07
-X1	PT-1-24-02-30	TP-03

NOTE: PARTS TO BE LOADED WITH POSITION #1 IN SAME DIRECTION AS ARROW ON TUBE

UNLESS OTHERWISE SPECIFIED, DIMENSIONS ARE IN INCHES.
 TOLERANCES ARE:
 DECIMALS ANGLES
 .XX: $\pm .01$ [.3] 2°
 .XXX: $\pm .005$ [.13]
 .XXXX: $\pm .0020$ [.051]

PROPRIETARY NOTE
 THIS DOCUMENT CONTAINS CONFIDENTIAL AND PROPRIETARY INFORMATION AND ALL DESIGN, MANUFACTURING, REPRODUCTION, USE, PATENT RIGHTS AND SALES RIGHTS ARE EXPRESSLY RESERVED BY SAMTEC, INC. THIS DOCUMENT SHALL NOT BE DISCLOSED, IN WHOLE OR PART, TO ANY UNAUTHORIZED PERSON OR ENTITY NOR REPRODUCED, TRANSFERRED OR INCORPORATED IN ANY OTHER PROJECT IN ANY MANNER WITHOUT THE EXPRESS WRITTEN CONSENT OF SAMTEC, INC.



520 PARK EAST BLVD, NEW ALBANY, IN 47150
 PHONE: 812-944-6733 FAX: 812-948-5047
 e-Mail: info@SAMTEC.com code: 53322

MATERIAL: DO NOT SCALE DRAWING SHEET SCALE: 2:1

INSULATOR: LCP, COLOR: BLACK
 CONTACT: PHOS BRONZE (-SP) or HIGH COPPER ALLOY (-HP)

DESCRIPTION:
 .165[4.19] SINGLE ROW SOCKET ASSEMBLY

DWG. NO. IPBS-1XX-XX-XX-S-XX

BY: DEAN P 5/12/2003 SHEET 1 OF 2

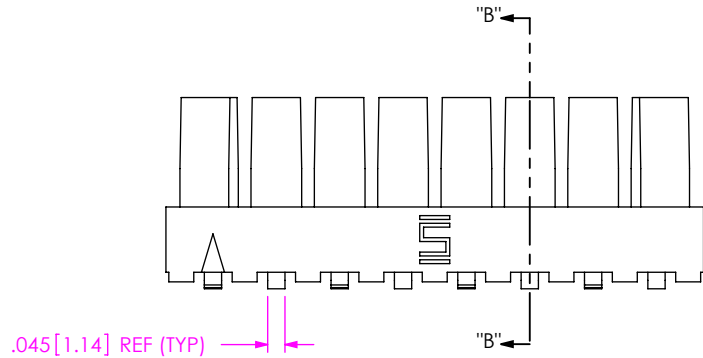
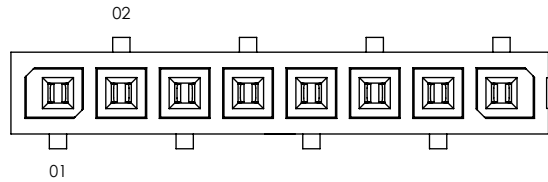
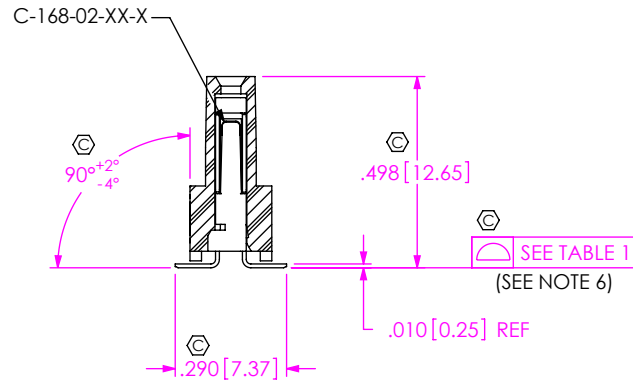

FIG. 2
 -X2: SURFACE MOUNT
 IPBS-108-X2-XX-S SHOWN
 [DIFFERENT AS SHOWN, OTHERWISE SAME AS FIG. 1]

TABLE 1	
No OF POSITIONS	COPLANARITY
-02 THRU -10	.004[.10]



SECTION "B"- "B"

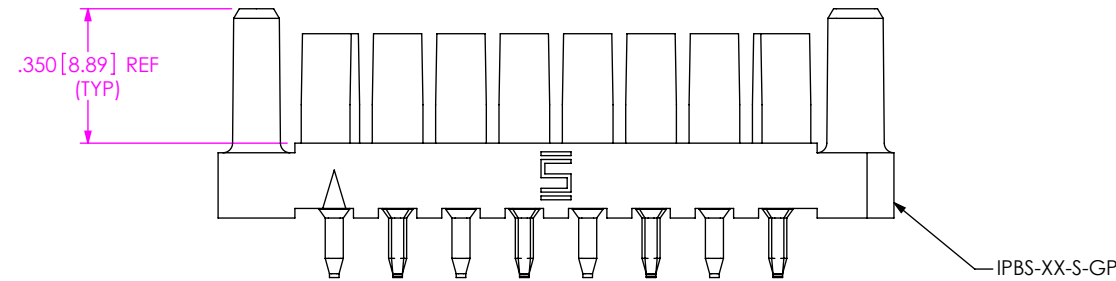
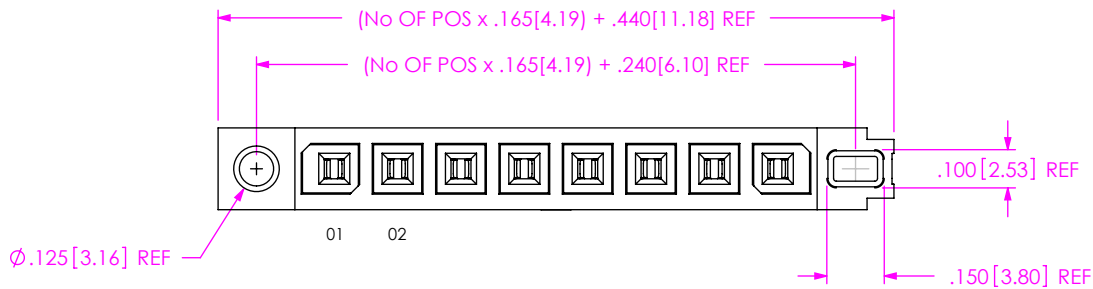

FIG. 3
 -GP: GUIDE POSTS
 IPBS-108-X1-XX-S-GP SHOWN
 [DIFFERENT AS SHOWN, OTHERWISE SAME AS FIG. 1]

PROPRIETARY NOTE
 THIS DOCUMENT CONTAINS CONFIDENTIAL AND PROPRIETARY INFORMATION AND ALL DESIGN, MANUFACTURING, REPRODUCTION, USE, PATENT RIGHTS AND SALES RIGHTS ARE EXPRESSLY RESERVED BY SAMTEC, INC. THIS DOCUMENT SHALL NOT BE DISCLOSED, IN WHOLE OR PART, TO ANY UNAUTHORIZED PERSON OR ENTITY NOR REPRODUCED, TRANSFERRED OR INCORPORATED IN ANY OTHER PROJECT IN ANY MANNER WITHOUT THE EXPRESS WRITTEN CONSENT OF SAMTEC, INC.

DO NOT SCALE DRAWING

SHEET SCALE: 2:1



520 PARK EAST BLVD, NEW ALBANY, IN 47150
 PHONE: 812-944-6733 FAX: 812-948-5047
 e-Mail: info@SAMTEC.com code: 55322

DESCRIPTION:
 .165[4.19] SINGLE ROW SOCKET ASSEMBLY

DWG. NO.
 IPBS-1 XX-XX-XX-S-XX

BY: DEAN P 5/12/2003 SHEET 2 OF 2