

REVISIONS					
P	LTR	DESCRIPTION	DATE	DWN	APVD
	B1	HOUSING CHANGE_PCN-23-176089	16JUN2023	SS	JDB

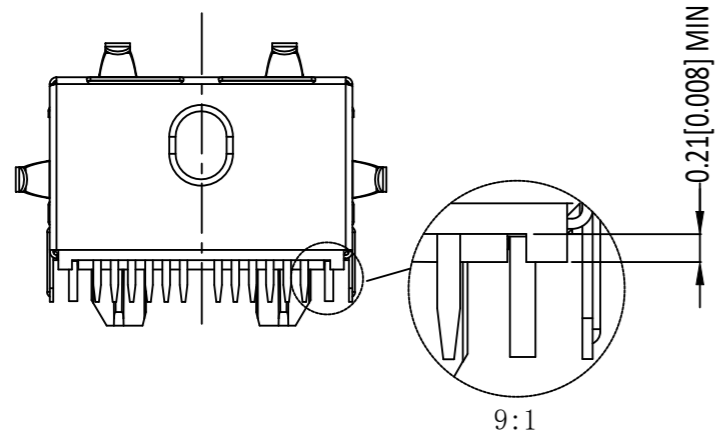

- ⚠ CONNECTOR MATERIAL:
 HOUSING: LCP BLACK UL94 V-0
 INSERT: LCP BLACK UL94 V-0
 SHIELD: BRASS
 SHIELD PLATING: NICKEL
 CONTACT: COPPER ALLOY
 CONTACT PLATING: SELECTIVE GOLD, MIN. 0.76µm (30µinch) IN CONTACT AREA
 OVER MIN. 1.27µm (50µinch) NICKEL
 SOLDER PIN PLATING: 3.05µm (120µinch) TIN OVER 1.27µm (50µinch) NICKEL
 OVER ALL
 SHIELDING PIN PLATING: NICKEL
- 2 PIN NOT ELECTRICALLY CONNECTED MAYBE OMITTED SEE ELECTRICAL CIRCUIT DIAGRAM FOR OMITTED PINS
- 3 RJ45 CAVITY DIMENSION CONFORM TO FCC PART 68
- 4 THE PART IS RECOMMENDED FOR REFLOW SOLDERING PROCESS PEAK SOLDERING: TEMPERATURE MAX. +260°C, MAX. 10s
- 5 OPERATING TEMPERATURE: T= -40°C TO +85°C
- 6 STORAGE TEMPERATURE: T= -40°C TO +85°C
- ⚠ UNLESS OTHERWISE SPECIFIED, SEE TABLE FOR ALL DIMENSIONS TOLERANCES
- 8 JACK CONFIGURATION: 1 x 1
 TAB DIRECTION: UP
- 9 PACKAGING: TRAY ACCORDING TO PACKAGING SPECIFICATION 107-18116

TABLE OF TOLERANCE (mm)	
RANGE	TOLERANCE
0-10	±0.15
>10-40	±0.25
>40-70	±0.30
>70	±0.40

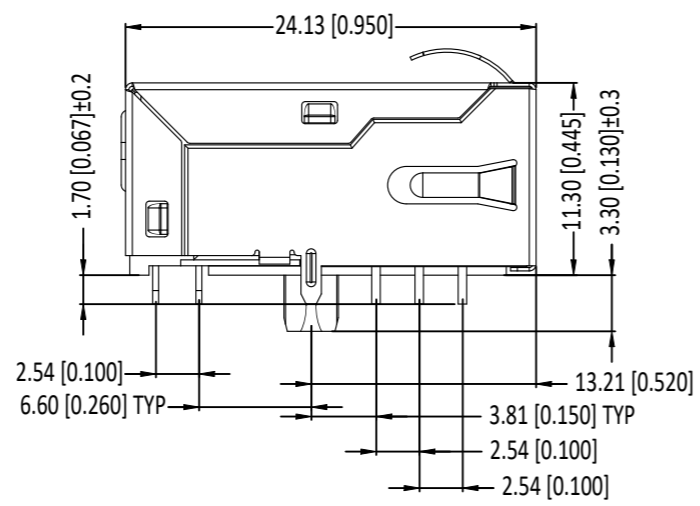
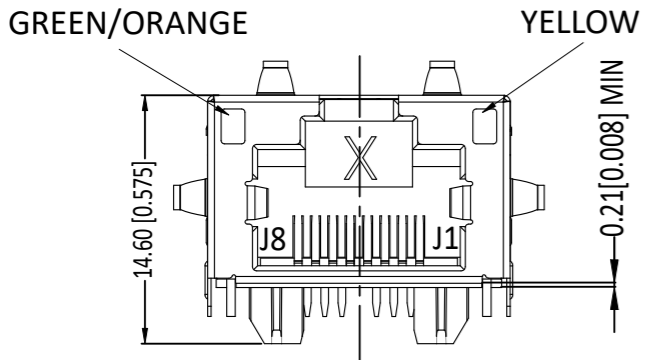
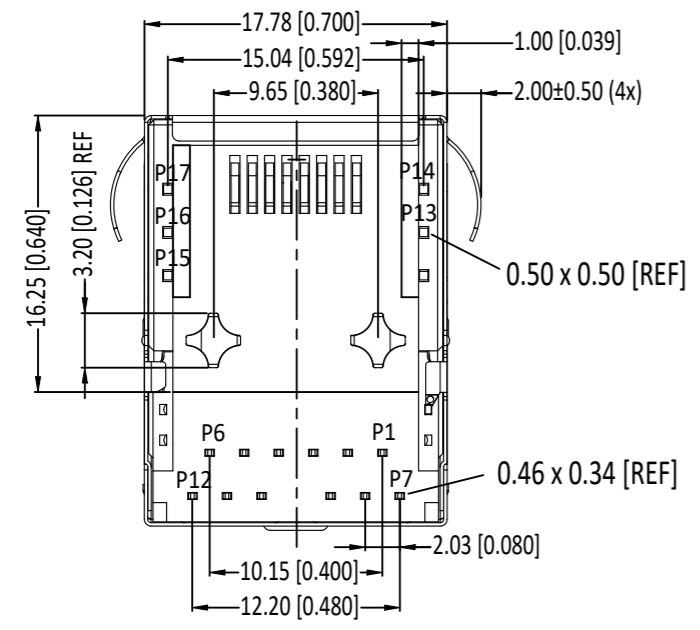
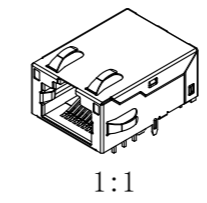

THIS DRAWING IS A CONTROLLED DOCUMENT.		DWN GAMESH C M 18JUL2019	TE Connectivity Ltd.		
DIMENSIONS: mm [INCHES]		CHK FRANZ MUELLER 18JUL2019			
TOLERANCES UNLESS OTHERWISE SPECIFIED:		APVD MARTIN SZELAG 18JUL2019	NAME RJ45 JACK INT.MAG. 1Gb LED 1x1 INV		
0 PLC ± - 1 PLC ± - 2 PLC ± - 3 PLC ± - 4 PLC ± - ANGLES ± -		PRODUCT SPEC 108-94552	-		
		APPLICATION SPEC 114-94447	SIZE A3	CAGE CODE 00779	DRAWING NO C=6-2301994-1
MATERIAL 1		FINISH 1	WEIGHT		RESTRICTED TO -
CUSTOMER DRAWING			SCALE 3:1	SHEET 1 of 3	REV B1

REVISIONS					
P	LTR	DESCRIPTION	DATE	DWN	APVD
-	-	SEE SHEET 1	-	-	-

SUGGESTED PCB LAYOUT

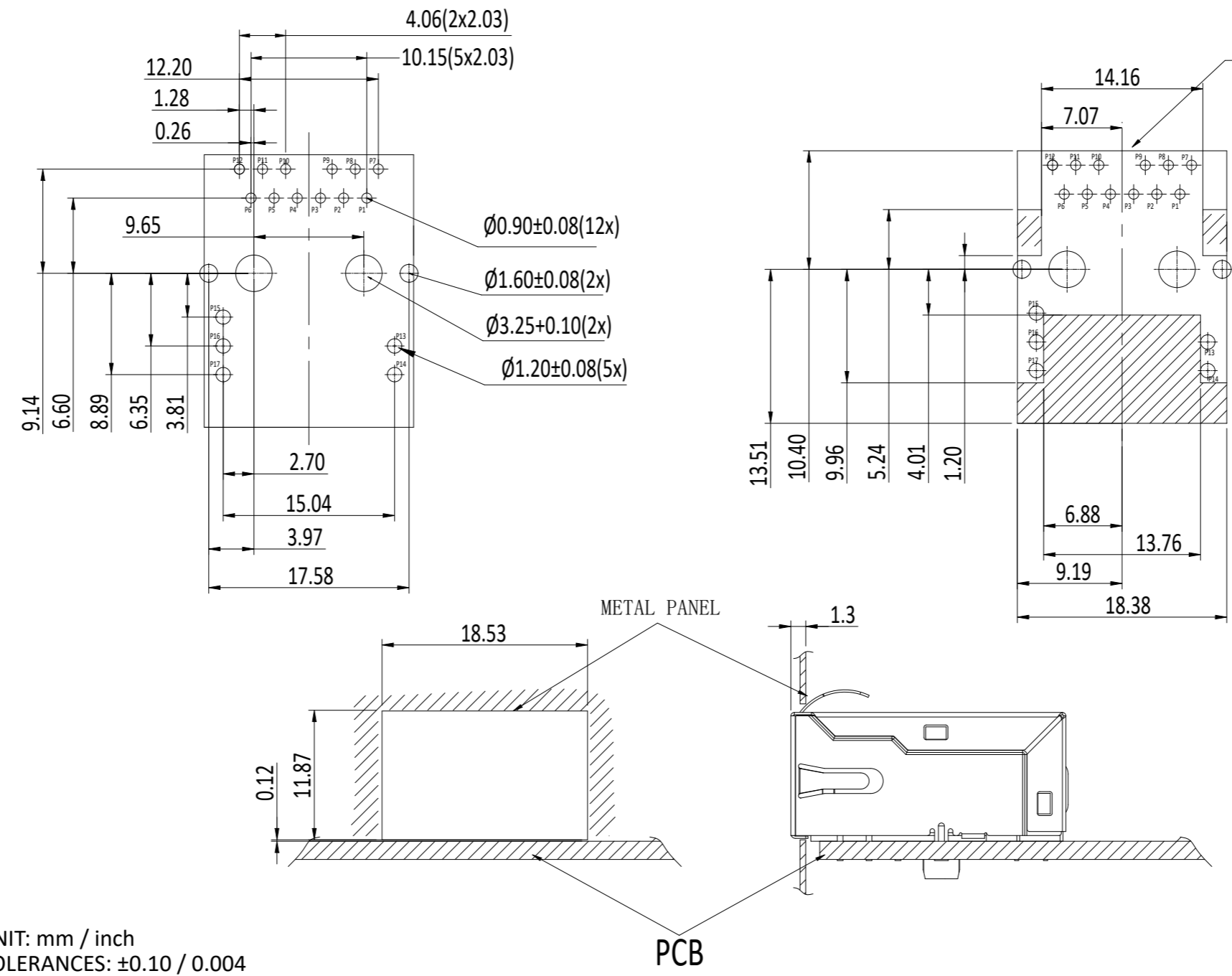

UNIT: mm / inch
 TOLERANCES: ±0.10 / 0.004
 ONLY FOR THIS VIEW

THIS DRAWING IS A CONTROLLED DOCUMENT.		DWN GAMESH C M 18JUL2019	 TE Connectivity Ltd.			
DIMENSIONS: mm [INCHES]		CHK FRANZ MUELLER 18JUL2019				
TOLERANCES UNLESS OTHERWISE SPECIFIED:		APVD MARTIN SZELAG 18JUL2019	NAME RJ45 JACK INT.MAG. 1Gb LED 1x1 INV			
0 PLC ± - 1 PLC ± - 2 PLC ± - 3 PLC ± - 4 PLC ± - ANGLES ± -		PRODUCT SPEC 108-94552	APPLICATION SPEC			
MATERIAL		114-94447	SIZE A3	CAGE CODE 00779	DRAWING NO C=6-2301994-1	RESTRICTED TO
FINISH		1	WEIGHT		SCALE 3:1	SHEET 2 OF 3
			CUSTOMER DRAWING		REV B1	

REVISIONS

P	LTR	DESCRIPTION	DATE	DWN	APVD
-	-	SEE SHEET 1	-	-	-

ELECTRICAL CIRCUIT DIAGRAM

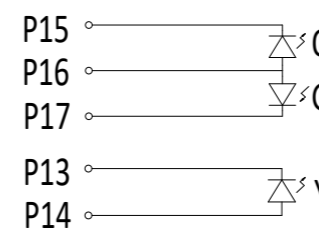
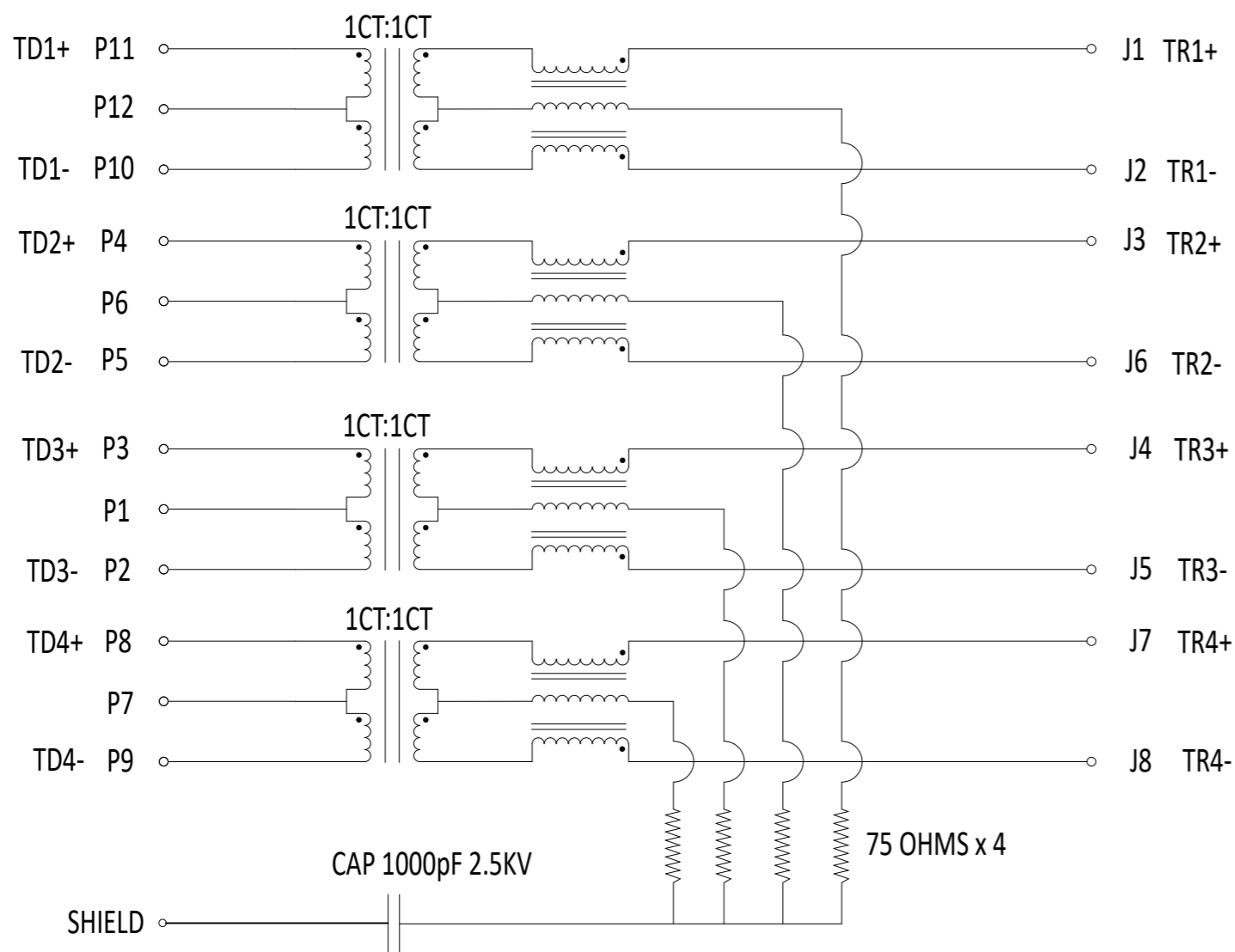

PIN	YELLOW	PIN	ORANGE	GREEN
P13	-	P15	-	-
P14	+	P16	+	+
		P17		-

WIRE BONDED, V_F = 1.8V ~ 2.4V, I_F = 20mA

- TURN RATIO @100KHz: (P11~P10):(J1~J2) = 1:1±2%
(P4~P5):(J3~J6) = 1:1±2%
(P3~P2):(J4~J5) = 1:1±2%
(P8~P9):(J7~J8) = 1:1±2%
- PRIMARY INDUCTANCE: 350uH MIN. @100KHZ, 0.1V 8mA DC BIAS
- DC RESISTANCE: 1.2 OHMS MAX.
- INSERTION LOSS: 1-100MHz -1.0dB MAX.
100-125MHz -1.2dB MAX.
- RETURN LOSS: 1-40MHz -16dB MIN. (@40MHz -17.0dB TYP)
40-100MHz -10dB+20log(f/80MHz) MIN.
(@100MHz -9.0dB TYP)
- CROSS TALK: 1-100MHz -30dB MIN.
- COMMON TO COMMON MODE ATTENUATION: 1-100MHz -30dB MIN.
- ISOLATION: PHY SIDE TO LINE SIDE: 2250VDC



CONTROL CODE

DATE CODE

"0213"

YY-YEAR

WW-WEEK

FCC

THIS DRAWING IS A CONTROLLED DOCUMENT.		DWN GAMESH C M 18JUL2019	TE Connectivity Ltd.															
DIMENSIONS: mm [INCHES]		CHK FRANZ MUELLER 18JUL2019																
TOLERANCES UNLESS OTHERWISE SPECIFIED:		APVD MARTIN SZELAG 18JUL2019	NAME RJ45 JACK INT.MAG. 1Gb LED 1x1 INV															
<table border="0"> <tr><td>0 PLC</td><td>± -</td><td rowspan="5">7</td></tr> <tr><td>1 PLC</td><td>± -</td></tr> <tr><td>2 PLC</td><td>± -</td></tr> <tr><td>3 PLC</td><td>± -</td></tr> <tr><td>4 PLC</td><td>± -</td></tr> <tr><td>ANGLES</td><td>± -</td><td></td></tr> </table>		0 PLC	± -	7	1 PLC	± -	2 PLC	± -	3 PLC	± -	4 PLC	± -	ANGLES	± -		PRODUCT SPEC 108-94552	SIZE A3	
0 PLC	± -	7																
1 PLC	± -																	
2 PLC	± -																	
3 PLC	± -																	
4 PLC	± -																	
ANGLES	± -																	
MATERIAL 1		FINISH 1	APPLICATION SPEC 114-94447	CAGE CODE 00779														
		WEIGHT	DRAWING NO 6-2301994-1	RESTRICTED TO -														
CUSTOMER DRAWING			SCALE 3:1	SHEET 3 OF 3														
			REV B1															