

**Please note that Cypress is an Infineon Technologies Company.**

The document following this cover page is marked as “Cypress” document as this is the company that originally developed the product. Please note that Infineon will continue to offer the product to new and existing customers as part of the Infineon product portfolio.

**Continuity of document content**

The fact that Infineon offers the following product as part of the Infineon product portfolio does not lead to any changes to this document. Future revisions will occur when appropriate, and any changes will be set out on the document history page.

**Continuity of ordering part numbers**

Infineon continues to support existing part numbers. Please continue to use the ordering part numbers listed in the datasheet for ordering.

# EZ-BT™ MODULE ARDUINO EVALUATION BOARD CYBT-353027-EVAL



The EZ-BT Module Arduino Evaluation Board (CYBT-353027-EVAL) enables you to evaluate and develop applications on the EZ-BT WICED Module, CYBT-353027-02. CYBT-353027-EVAL can be used as a standalone evaluation kit or can be combined with Arduino compatible shields.

The CYBT-353027-02 WICED Module is fully integrated, fully certified, 9.0 mm x 9.0 mm x 1.75 mm, programmable, Bluetooth® Smart Ready module designed to reduce your time-to-market.

For more information, visit:

[www.cypress.com/bluetooth\\_modules](http://www.cypress.com/bluetooth_modules) - EZ-BLE/EZ-BT Module home pages

[www.cypress.com/EZ-Serial](http://www.cypress.com/EZ-Serial) - EZ-Serial Bluetooth Firmware Platform page

[www.cypress.com/WICED](http://www.cypress.com/WICED) - WICED Platform page

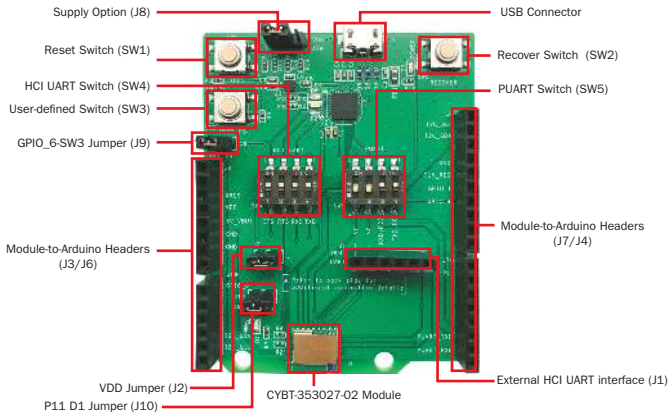

**Figure 1: : CYBT-353027-EVAL Top View**

To use the CYBT-353027-EVAL:

- 1) Configure the evaluation board headers/switches to the desired settings
- 2) Connect the evaluation board to a PC via a USB cable
- 3) Refer to KBA223509 for platform files, Makefile target generation, and HCI UART switch position setting for programming
- 4) Open the WICED Studio IDE, develop your application, program and test

The Arduino compatible headers (J3/J4/J6/J7) are optional connections, which provide additional I/O connections to the module and allow for other Arduino shields to be used during development.

# EZ-BT™ MODULE ARDUINO EVALUATION BOARD

## CYBT-353027-EVAL



**Figure 2: CYBT-353027-EVAL Bottom View**

SW1: Reset Switch routed to the XRES connection on the module.

SW2: Recover Switch routed to the SPI2\_CS\_N connection on the module.

SW3: User-defined Switch routed to the GPIO\_6 connection on the module via J9.

SW4: Switch connecting HCI UART connections on the module to host via USB.

SW5: Switch connecting PUART connections on the module to host via USB.

J1: Connection for external interface for direct HCI UART communication.

J2: Used for power supply current measurement.

J3/J4/J6/J7: Arduino-compatible headers used with an Arduino compatible shield.

J8: Configures the VDD voltage input to the module as shown in the below table:

J8 Jumper Configuration	VDD Voltage Level
Short 1 & 2	3.6V
Short 2 & 3	3.3V
No Jumper	2.3V

J9: Connects the GPIO\_6 pad on the module to SW3.

J10: Connects the P11 pad on the module to LED D1.

The EZ-BT CYBT-353027-02 module supports Bluetooth SIG Mesh, is qualified for the Bluetooth 5.0 specification and are certified for the 2.4 GHz unlicensed frequency range in USA (FCC), Canada (ISED), Europe (CE) and Japan (MIC).

Visit [www.cypress.com/support](http://www.cypress.com/support) for technical support.