



AK5371

2ch A/D Converter with USB I/F

Features:

- **USB-IF Certified**
- **Incorporates USB Audio Controller**
USB Serial Interface Engine
Audio Class Encoder/Decoder
2 Endpoints (FIFO)
USB transceiver
- **16 bit A/D Converter**
2 channels
Mute/Volume Control
A/D S/N: 84dBA (44.1kHz, Gain = 0dB)
- **Low Power Dissipation**
Normal Operation: 26mA
Suspend Mode: < 1uA
- **Programmable Gain Amplifier (IPGA)**
+24dB to -31dB @1dB Step
- **20dB Pre-amplifier**
- **On-chip PLL**
5 Sampling Frequencies support
8kHz, 11.025kHz
22.05kHz, 44.1kHz, 48kHz
- **EEPROM I/F**
can customize Device Descriptor,
and String Descriptor
- **Single Power Supply, Low Power**
+3.3±0.3 Volts
- **Package**
48pin LQFP, 48pin QFN

General Description

The AK5371 is stereo A/D converter with USB I/F. The AK5371 integrates USB serial interface engine, USB transceiver, audio class processing unit, endpoints, and high quality 2 channel AD converter into the chip.

As the AK5371 incorporates PLL, it can support several sampling frequencies, 8kHz, 11.025kHz, 22.05kHz, 44.1kHz, and 48kHz with only one crystal. Moreover, the AK5371 integrates volume control, and mute function.

Not only power consumption at normal operation is very low, but also the current at suspend mode is less than 1μA.

The AK5371 includes 20dB fixed gain pre-amplifier. In addition to this, as the AK5371 also incorporates IPGA which can amplify the microphone signal up to +24dB, total gain is 44dB maximum.

The AK5371 has EEPROM I/F for customizing Device Descriptor and String Descriptor. By connecting 1K bit, 2K bit, or 4Kbit Microwire™ type EEPROM, the AK5371 can customize Vendor ID, Product ID in Device Descriptor, and String Descriptor.

This device is good for not only business application such as conferencing but also games, voice recognition, and Karaoke.

Related Documents

For the detail of USB specification, and Audio Class, please refer to the following documents.

Universal Serial Bus Specification Revision 1.1
 Universal Serial Bus Device Class Definition for Audio Devices, Revision 1.0



■ Block Diagram

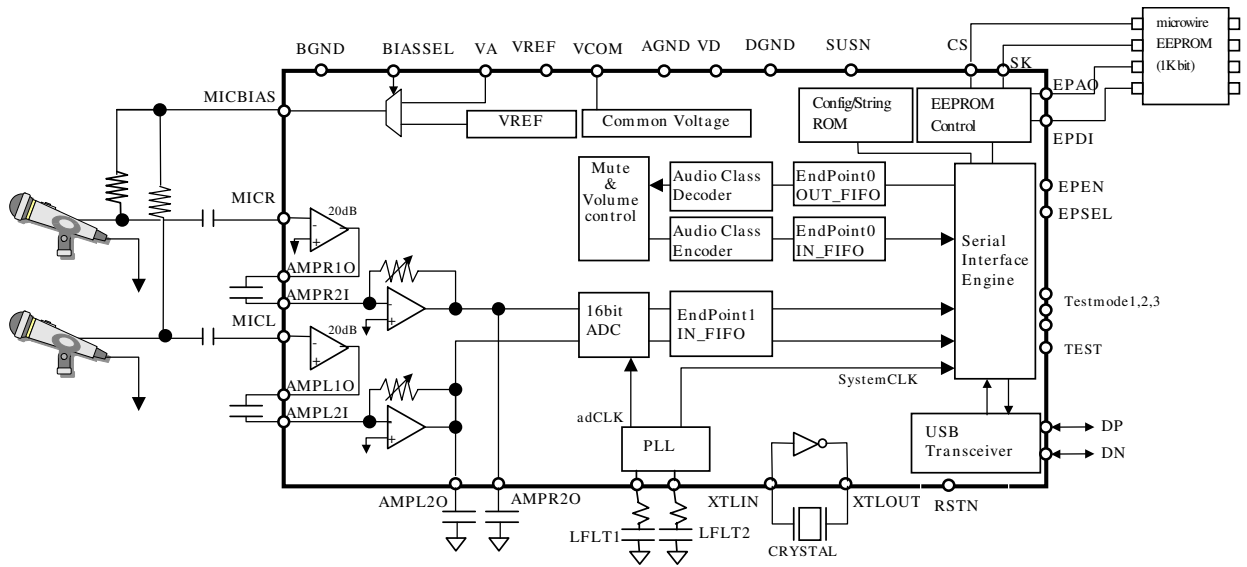

■ Ordering Guide

AK5371VQ	0 ~ +70 °C	48pin LQFP (0.5mm pitch)
AK5371VN	0 ~ +70 °C	48pin QFN (0.4mm pitch)
AKD5371	Evaluation Board	

■ Pin Layout

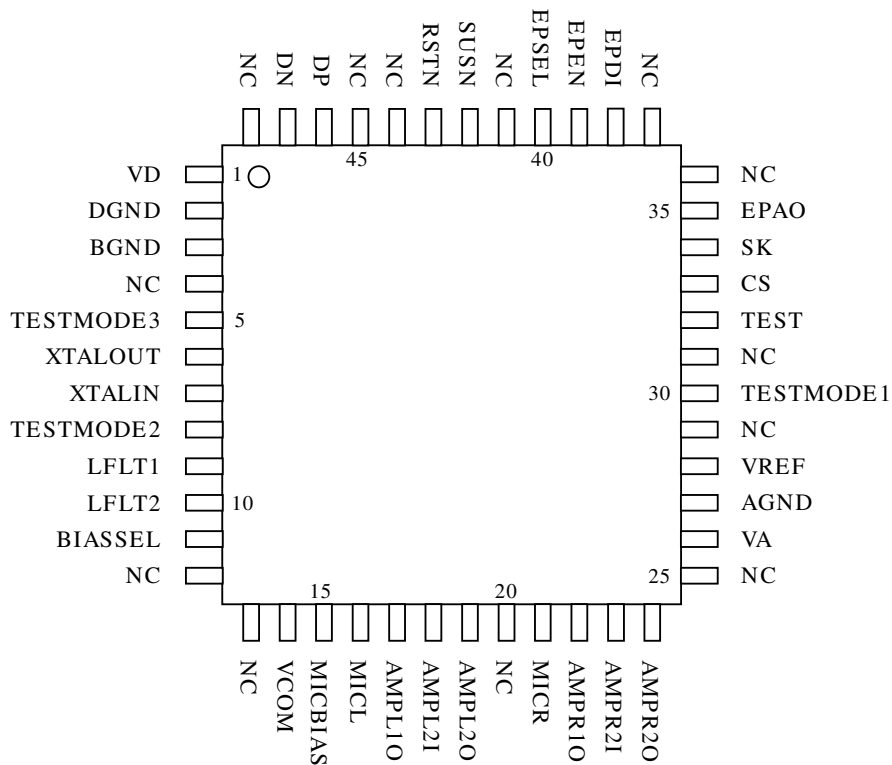

Pin/Function				
No.	Signal Name	I/O	Ana / Dig	Description
1	VD	P	D	Digital Power Supply, 3.3V
2	DGND	P	D	Digital Ground,0V
3	BGND	P	D	Bulk Ground, 0V
4	NC	-	-	No Connection
5	TESTMODE3	I	D	Please tie down to AGND for normal operation.
6	XTALOUT	O	A	Crystal Oscillator Output, Connect Crystal Resonator
7	XTALIN	I	A	Crystal Oscillator Input, Connect Crystal Resonator
8	TESTMODE2	I	A	Please tie down to AGND for normal operation.
9	LFLT1	O	A	adPLL loop filter Pin. Connect 51kΩ resistor and 8200pF capacitor in series externally.
10	LFLT2	O	A	System clock PLL loop filter Pin. Connect 18kΩ resistor and 6800pF capacitor in series externally.
11	BIASSEL	I	D	MIC BIAS Select Pin Select MICBIAS Output "L": VA(through switch) "H": VREF buffer output
12	NC	-	-	No Connection
13	NC	-	-	No Connection
14	VCOM	O	A	Analog Common Voltage Reference Pin
15	MICBIAS	O	A	Voltage Reference Output for the Microphone's bias voltage When this chip goes into Suspend mode, this pin goes to Hi-Z.
16	MICL	I	A	Left Channel Microphone Input
17	AMPL1O	O	A	Left Channel 1 st Amplifier Output Pin
18	AMPL2I	I	A	Left Channel 2 nd Amplifier Input Pin
19	AMPL2O	O	A	Left Channel 2 nd Amplifier Output Pin
20	NC	-	-	No Connection
21	MICR	I	A	Right Channel Microphone Input
22	AMPR1O	O	A	Right Channel 1 st Amplifier Output Pin
23	AMPR2I	I	A	Right Channel 2 nd Amplifier Input Pin
24	AMPR2O	O	A	Right Channel 2 nd Amplifier Output Pin

No.	Signal Name	I/O	Ana / Dig	Description
25	NC	-	-	No Connection
26	VA	P	A	Analog Power Supply, 3.3V
27	AGND	P	A	Analog Ground,0V
28	VREF	O	A	ADC Common Voltage Reference Pin.
29	NC	-	-	No Connection
30	TESTMODE1	I	A	Please tie down to AGND for normal operation.
31	NC	-	-	No Connection
32	TEST	I/O	D	Please tie down to AGND for normal operation.
33	CS	O	D	EEPROM I/F Chip Select Pin
34	SK	O	D	Serial Clock Pin
35	EPAO	O	D	EEPROM Address Output Pin
36	NC	-	-	No Connection
37	NC	-	-	No Connection
38	EPDI	I	D	EEPROM Data Input Pin (This pin is internally pulled down)
39	EPEN	I	D	EEPROM Enable Pin "H" : Read Device Descriptor, String Descriptor from EEPROM "L" : Read Device/String Descriptor from internal ROM. Note that CS,SK,EPDI,EPAO is Hi-Z when EPEN is "L"
40	EPSEL	I	D	EEPROM Select Pin "L" : 1Kbit Type EEPROM is connected. "H" : 2Kbit/4Kbit EEPROM is connected If EEPROM is not used, EPSEL should be tied to DGND.
41	NC	-	-	No Connection
42	SUSN	O	D	Suspend Status Pin "L" : Suspend State "H" : Normal Operation
43	RSTN	I	D	Reset Pin, Low input makes the chip reset safe. Schmitt Trigger input.
44	NC	-	-	No Connection
45	NC	-	-	No Connection
46	DP	I/O	D	USB bus Non-Inverting pin. Because AK5371 is full speed mode device, 1.5kΩ resistor will be connected between D+ node to VD.
47	DN	I/O	D	USB bus Inverting Pin.
48	NC	-	-	No Connection

Absolute Maximum Rating

AGND, DGND=0V

Parameter	Symbol	Min	Max	Units	
Power Supplies	Analog	VA	-0.3	4.5	V
	Digital	VD	-0.3	4.5	V
	DGND-AGND	ΔGND		0.3	V
Input Current (any pins except for supplies)	IIN	-	±10	mA	
Analog Input Voltage	VINA	-0.3	VA+0.3	V	
Digital Input Voltage	VIND	-0.3	VD+0.3	V	
Ambient Temperature	Ta	0	70	°C	
Storage Temperature	Tstg	-40	125	°C	

Note 1. All voltages with respect to ground

Warning: Operation at or beyond these limits may results in permanent damage to the device. Normal operation is not guaranteed at these extremes.

Recommended Operating Condition

AGND, DGND=0V

Parameter	Symbol	Min	typ	Max	Units	
Power Supplies	Analog	VA	3.0	3.3	3.6	V
	Digital	VD	3.0	3.3	3.6	V

All voltages with respect to ground.

* AKM assumes no responsibility for the usage beyond the condition in this datasheet.

Analog Characteristics

Ta=25°C, VA=VD=3.3V, Signal Frequency=1kHz, Sampling Frequency Fs=44.1kHz BW=20Hz – 20kHz, Test Mode; unless otherwise specified

Parameter	Min	typ	Max	Units	
Stereo ADC (2 channel)					
Resolution			16	bits	
S/N (A weight) (AMPR2I/AMPL2I input) (IPGA are set to 0dB) USB Normal Mode		84		dBA	
S/(N+D) (-1dB analog input) (IPGA are set to 0dB) USB Normal Mode		70		dB	
MIC Amplifier (2nd Stage) <IPGA> Characteristics					
Full Scale Input Voltage	1.5	1.7	1.9	Vp-p	
Gain Control Range	-31		+24	dB	
Step Size	0	1.0	2.0	dB	
Input Impedance @AMPR2I/AMPL2I pin		40		KΩ	
MIC Amplifier (1st Stage)					
Gain range		+20		dB	
Input Impedance @MICR/MICL	10	20		KΩ	
S/N (A weight) @MICR/MICL to AMPRIO/AMPLIO		77		dBA	
MIC Bias (VA)					
Output Voltage when 4.7KΩ resistor connected	2.0			Vdc	
Output Impedance		200	500	Ω	
Output Current			2	mA	
MIC Bias (Buffer Amp)					
Output Voltage when 300Ω resistor connected	1.9	2.2	2.5	Vdc	
Output Current			2	mA	
Power Supplies					
	Analog		17	25	mA
	Digital		9	15	mA
	Total		26	40	mA
	Power Down (Suspend Mode)		0	160	uA

FILTER CHARACTERISTICS

(Ta=25°C VA, VD =3.0 - 3.6 V ; fs = 44.1 kHz)

Parameter		Symbol	Min	typ	Max	Units
A/D Digital Filter (Decimation LPF)						
Passband	+/- 0.2 dB	PB	0		17.64	KHz
Stopband		SB	26.5			KHz
Passband Ripple		PR			+/- 0.2	dB
Stopband Attenuation		SA	68			dB
Group Delay		GD			0.5	ms
A/Ddigital Filter (HPF)						
Frequency Response	-3 dB	FR		6.85		Hz
	-0.5 dB			19.2		Hz
	-0.1 dB			44.9		Hz

Digital DC Characteristics

Ta=0 - 70°C; VD=3.0 - 3.6V; DGND=0V Measurement under static state

All digital pins except DP, DN. Schmitt hysteresis level of RST pin and levels of all test pins will not be tested.

Parameter	Symbol	Min	Typ	Max	Units
EPDI, EPEN, EPSEL, pin "H" level input voltage	VIH	70%VD			V
EPDI, EPEN, EPSEL pin "L" level input voltage	VIL			30%VD	V
RSTN pin "H" level voltage	VIHR	2.0			V
RSTN pin "L" level voltage	VILR			0.8	V
CS, SK, EPAO, SUSN pin "H" level output voltage IOH = 2mA	VOH	2.4			V
CS, SK, EPAO, SUSN pin "L" level output voltage IOL = -2mA	VOL			0.6	V
Input Leakage Current	Iin			±10	µA

Switching Characteristics

Ta=25°C, VA=VD=3.3V

Parameter	Symbol	Min	Typ	Max	Units
Master Clock Frequency	MCLK	-	11.2896	-	MHz
Reset input width @RSTN pin(low active)	Wrst	1.0			us
DP, DN Single Ended Receiver Threshold for H level for L level	VseH VseL	2.0		0.8	V
Time Width for USB Reset Signal Recognition*1 DP < VseL & DN < VseL to USB Reset mode	Trst_rec	2.7			µs
Device Ready Time from USB Reset Ready for transaction after reset	Tdrr			10	ms
Time Width for Suspend Recognition Idle state (DP > VseL & DN < VseL) to Suspend mode	Tsus_rec	3.0			ms
Resume Time from Suspend First flip of DP/DN from Idle sate To Device Ready*)	Tresm			30	ms

Device Ready: VREF, X'tal oscillator, and PLL get stable and bus transaction with normal rate is ready.

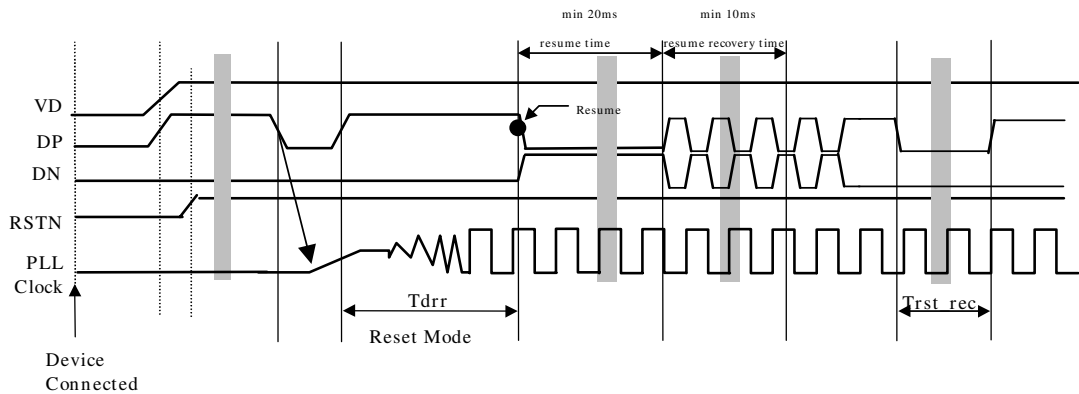

Figure 1. Mode change with respect to BUS States 1 (Power on and device connected)

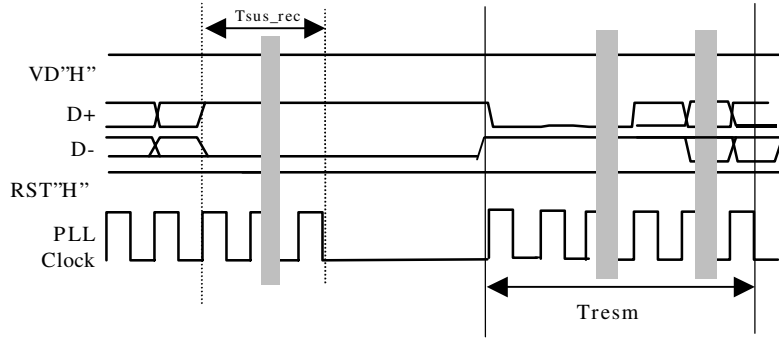

Figure 2. Mode Change with respect to Bus States 2 (Bus transactions)

Transmitter Characteristics							
Ta=25°C; VD=3.3V; DGND=0V; CL=50pF							
Parameter	Symbol	Pins	Conditions	Min	Typ	Max	Units
Data Rate	DR	DP, DN		11.97	12	12.03	MHz
Output Impedance (Hi)	Roh	DP, DN	DP, DN="H" at Iout = -10mA		36		Ω
Output Impedance (Lo)	Rol	DP, DP	DP, DN="L" at Iout = 10mA		36		Ω
"H" level Output Voltage	Vohd	DP, DN	at Iout = -200uA	2.8			V
"L" level Output Voltage	Vold	DP, DN	at Iout = 2.2mA			0.3	V
Tri-state Leakage Current	Iolk	DP, DN	0 < DP, DN < 3.3V	-10		10	μA
Rise/Fall Time	Trf/Tff	DP, DN		4	10	20	ns
Rise/Fall Time Matching	Trfm	DP, DN			100		%
Crossover Point	Vcrs	DP, DN			1.65		V

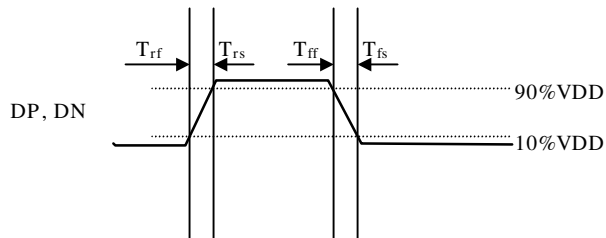

Figure 3. Rise/Fall Time

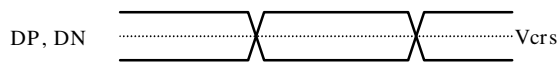

Figure 4. Crossover Point

Receiver Characteristics							
Ta=25°C; VD=3.3V; DGND=0V							
Parameter	Symbol	Pins	Conditions	Min	Typ	Max	Units
Common Mode Range	CMR	DP, DN		0.8			V
Differential Input Sensitivity	DIS	DP, DN		200			mV
Schmitt High Level Voltage	VihS	DP, DN		2.0			V
Schmitt Low Level Voltage	VilS	DP, DN				0.8	V

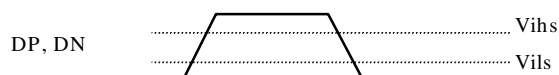

Figure 5. Schmitt Level Voltage

■ Overview of AK5371

The AK5371 is the advanced stereo A/D converter, which converts analog signal into USB audio class formats. As the AK5371 incorporates all functions to build USB Audio Input Device, the AK5371 doesn't require additional micro-controller, memory, and a transceiver. Moreover, as the AK5371 also has 20dB fixed gain pre-amplifier in addition to programmable gain amplifier (IPGA) whose range is from +24dB to -31dB, this device is suitable for USB microphone, especially microphone array. USB microphone can be manufactured easily by only four main components; the AK5371, one crystal, one regulator, and microphone unit(s). As the AK5371 also has EEPROM interface, descriptors can be customized easily. The AK5371 includes the following blocks:

1. 2 channel 16bit A/D converter
 - a) 84dBA@fs=44.1kHz
2. Programmable Gain Amplifier (IPGA)
 - a) Gain Range: from +24dB to -31dB,
 - b) Gain Step: 1dB/step
3. Fixed Gain Preamplifier
 - a) 20dB
4. FIFO
Synchronization between A/D converter and USB bus
 - a) Memory Size 400 bytes (16bit wide x 100 depth x 2 channel)
5. PLL
 - a) 11.2896MHz crystal
 - b) Two PLLs
 - A/D_PLL: generate clock for fs=8kHz, 48kHz
 - System_PLL : generate USB system clock
6. Audio Format
 - a) supports 5 frequencies : 8kHz, 11.025kHz, 22.05kHz, 44.1kHz, 48kHz
 - b) 2 audio formats
 - mono 16bit LSB first
 - stereo 16bit LSB first
7. USB Serial Interface Engine
 - a) Process USB Standard Requests
8. Control block of Audio Device Class
 - a) Translate internal A/D format to USB audio class format
 - b) Process USB Audio Class Request
 - Mute
 - Gain/Attenuation
 - Sampling Frequency Control
9. USB transceiver
10. EEPROM I/F
Microwire™ (4-wire) type EEPROM can be used to customize Device/String Descriptor.
 - 1K bit (AK93C45A)
 - 2K bit (AK93C55A)
 - 4Kbit (AK93C65A)
11. USB Suspend/Resume Support

The AK5371 supports 5 sampling frequencies (8kHz, 11.025kHz, 22.05kHz, 44.1kHz, 48kHz). In order to support these frequencies, the AK5371 incorporates PLL, which generates system clock and master clock for fs=8kHz, and 48kHz

Mute, volume and audio format including sampling frequency are controlled by USB audio class request.

The AK5371 goes to suspend mode when the device doesn't receive SOF for the period more than 3ms. All blocks including master clock stop the function to observe USB specification, 500μA, until receiving the resume signal. The AK5371 notifies the current state (normal state or suspend state) by SUS_N pin.

As the AK5371 has Microwire™ EEPROM I/F, the vendors can customize iManufacturer, iProduct, and the related strings to their own ID, and string.

■ Descriptor Overview

When the device is connected to USB bus, the host assigns specific address to the device. Then the host reads the device information, which is called as descriptor, through default pipe (Endpoint 0). The AK5371 consists of one Device Descriptor, one Configuration Descriptor, two Interface Descriptors, and two Endpoint Descriptors.

Figure 6 shows Descriptor's hierarchy.

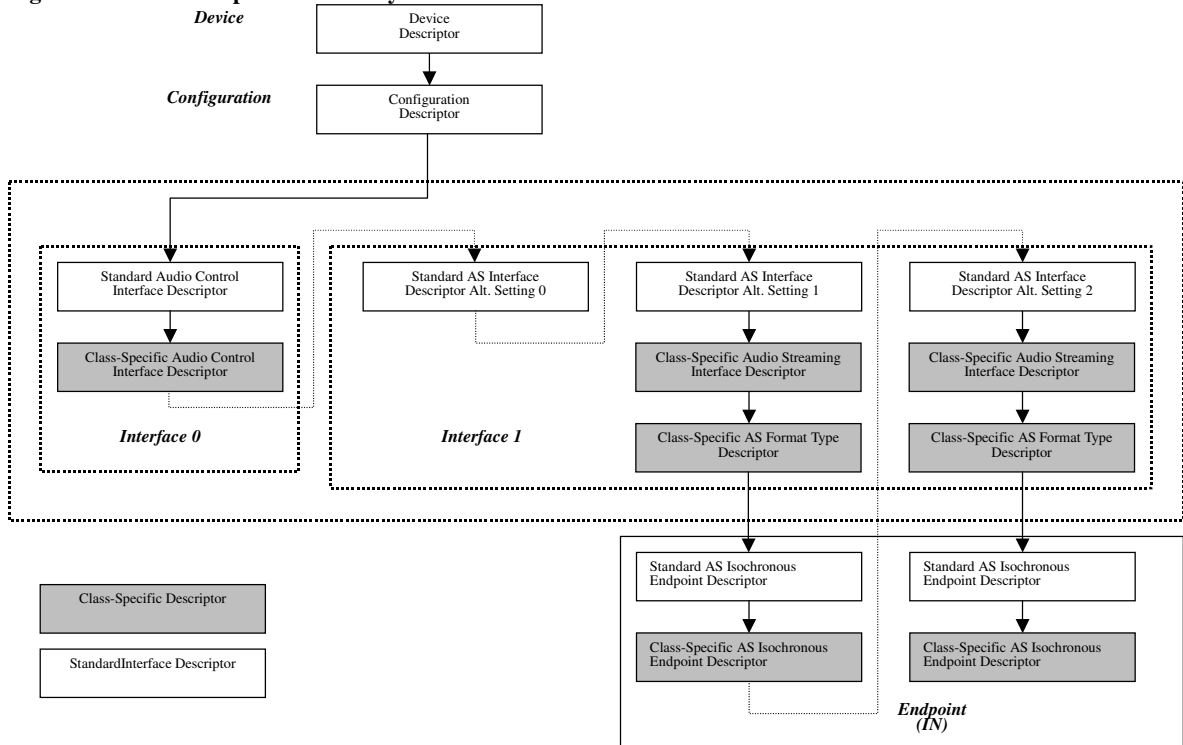

Figure 6. Descriptor Hierarchy

■ Audio Format of the AK5371

The AK5371 supports two audio formats: 16bit/mono and 16bit/stereo. This feature can avoid the unnecessary occupation of USB bandwidth. 16bit/mono is assigned to <Interlace 1, Alt1>, 16bit/stereo is assigned to <Interface 1, Alt2>. The A/D data on USB bus is LSB first, Left channel first. When 16bit/mono audio format is selected, the AK5371 outputs left channel data on the USB bus. Audio format is changed by "Set Interface" Request.

■ Synchronization

The AK5371 operates as Asynchronous Device. A/D converter in the AK5371 operates asynchronously with USB SOF timing. The data from A/D converter are sent continuously to a buffer memory while the data are burstly transferred at the interval of SOF on the USB. In order to arbitrate the difference of timing, AK5371 has a FIFO memory with a capacity of 2-frame depth. The average sampling rate calculating from USB frame should be in accordance with A/D sampling rate (fs).

The AK5371 sends all A/D samples that were stored in the last frame to avoid overflow or underflow of FIFO. The following figure shows an example. When sampling frequency is set to 44.1kHz, the AK5371 sends 45 samples once per ten times, and sends 44 samples in other frames. Average frequency is 44.1kHz. See **Figure 7**.

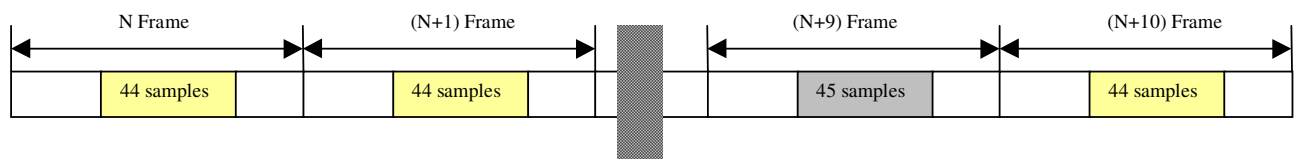

Figure 7. Synchronization

■ Power Management Control

When idle state continues for 3ms, the AK5371 goes to suspend state and forces almost all blocks including PLL, ADC block and mic bias into stopping in order to observe 500μA, which is USB suspend current requirement.

The device resumes the normal operation within 30ms after the device receives resume signal. In the normal operation, MICBIAS outputs the voltage to supply the microphone's bias voltage.

SUSN pin shows USB bus status; suspend mode ("L") or normal operation ("H"). SUSN pin can be used for external power control.

The AK5371 is very low power device at both normal state and suspend state. However, note that USB suspend current requirement, 500μA, specifies the current which is totally consumed by not only the AK5371, by also regulator(s), and resistors. Therefore, low power regulator should be selected to design USB microphone.

■ Feature Unit Control & Frequency Control

When the AK5371 receives "SET_FEATURE_UNIT_CONTROL" request, the device decodes the request and sets the value. Note that only CUR value is valid for "SET_FEATURE_UNIT_CONTROL" request, and that MIN/MAX/RES value is invalid. When the AK5371 receives "GET_FEATURE_UNIT_CONTROL" request, the device decodes the request and returns the value to the host. CUR/MAX/MIN/RES value is valid for "Get Volume Request", but only CUR value is meaningful for "Get Mute Request".

When the AK5371 receives "SET_ENDPOINT_CONTROL" request, it changes sampling frequency(fs). If fs is not supported, the device forces to set the appropriate fs which it supports. When the AK5371 receives "GET_ENDPOINT_CONTROL" request, it sends back the current value to the host.

■ EEPROM I/F

The AK5371 has EEPROM I/F for customizing Device Descriptor, and String Descriptor. idVendor(2byte), idProduct(2byte), bcdDevice(2byte), iManufacturer(1byte), iProduct(1byte) in Device Descriptor and related String Descriptor can be customized. Microwire™ type, 1K bit, 2K bit, or 4K bit EEPROM can be used. Note that word length of iManufacturer and iProduct is fixed to 52 bytes each for 1K bit EEPROM, 102 bytes for 2K/4K bit EEPROM.

The AK5371 automatically reads Device Descriptor from the EEPROM and stores internal memory after USB reset. When the AK5371 receives "GET String Descriptor" request, the AK5371 starts reading from EEPROM. The AK5371 continues to send NAK packet while it is reading String from EEPROM.

Memory mapping of EEPROM is the following.

	1K bit (AK93C45A)	2K/4K bit (AK93C55A / 65A)
Device Descriptor (18 bytes)	00h - 08h	00h - 08h
String Descriptor Lang ID (4 bytes index = 0)	09h - 0Ah	09h - 0Ah
String Descriptor iManufacturer (52 or 102bytes index =1)	0Bh - 24h	0Bh - 3Dh
String Descriptor iProduct (52 or 102 bytes index = 2)	25h - 3Eh	3Eh - 71h

Note that EEPROM address is 16bit boundary.

If 2K/4K bit EEPROM is used, EPSEL pin should be tied to VD. If 1K bit EEPROM is connected to the device, EPSEL should be tied to digital ground.

Device Descriptor and String Descriptor should be stored in EEPROM before the AK5371 is powered up. EPEN pin should be tied to "H" to activate if Descriptors are read from external EEPROM.

If internal ROM is used, not only EPEN pin but also EPSEL pin should be tied to DGND. Note that CS pin, SK pin, and EPAO pin are Hi-Z state when EPEN is "L". EPDI pin is internally pulled down.

■ System Block Diagram

The following figure shows the system connection diagram. This is an example which uses external 1K bit EEPROM (AK93C45A) as Device and String Descriptor. If EEPROM is not used, EPEN pin should be tied to DGND.

Ceramic capacitors (0.1uF) for VA pin, VD pin, VREF pin and VCOM pin should be located as near as possible.

<REMARK> This drawing does NOT mean physical pin locations/ordering

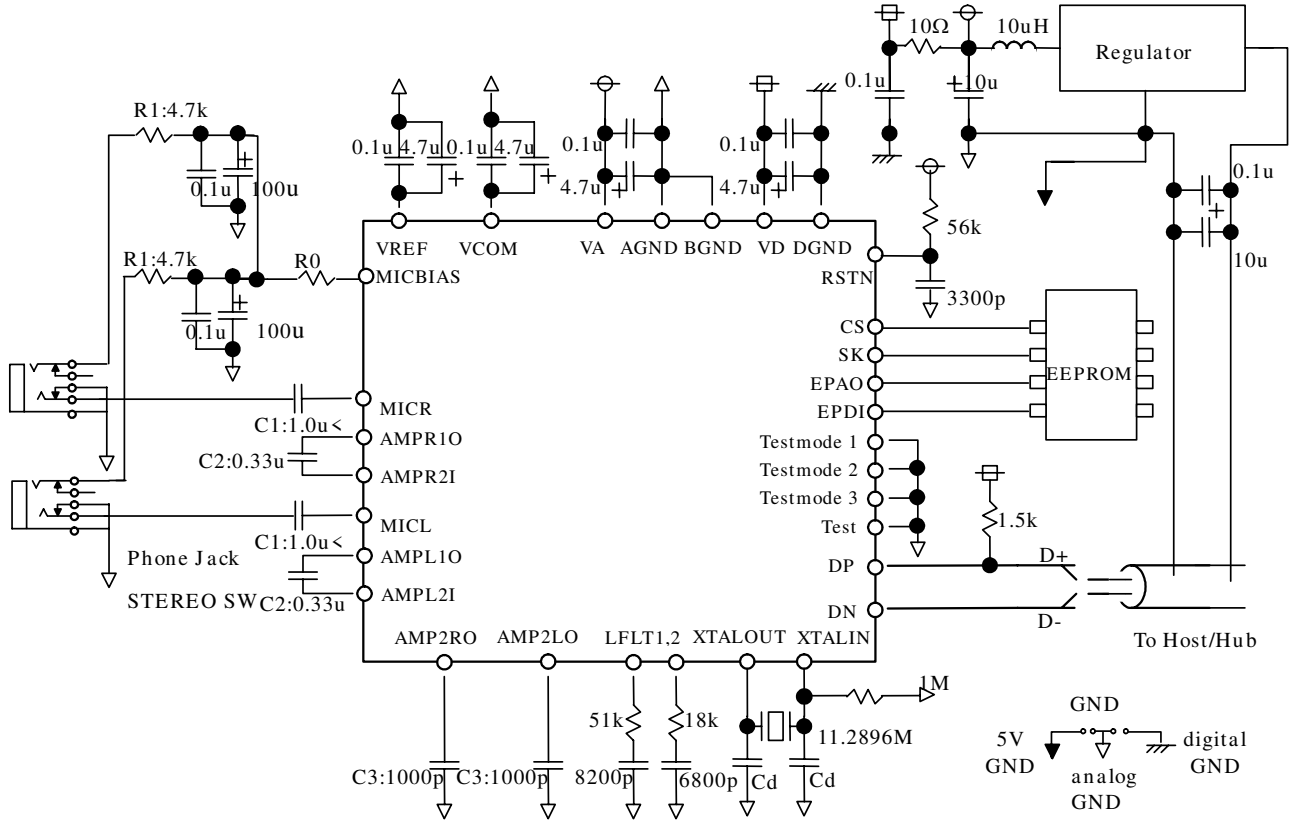

- C1 is specified for lower end cut-off frequency
- C3 forms Anti-aliasing filter in conjunction with the internal resistor at AMPR2O/AMPL2O
- R0: 0Ω resistor when BIASSEL is Low. 330Ω resistor when BIASSEL is High
- Cd: Please select the appropriate value according to crystal resonator's characteristics

AK5371 Descriptors Specification

1 Device descriptor

Offset	Field	Size	Value	Description
0	bLength	1	0x12	Size of this descriptor in bytes
1	bDescriptorType	1	0x01	DEVICE descriptor
2	bcdUSB	2	0x0110	1.10 – current revision of USB spec.
4	bDeviceClass	1	0x00	Device defined at Interface level
5	bDeviceSubClass	1	0x00	Unused
6	bDeviceProtocol	1	0x00	Unused
7	bMaxPacketSize0	1	0x08	8 bytes
8	idVendor	2	0x0556	AKM's Vendor ID
10	idProduct	2	0x0002	00 means Audio Product, 02 is AKMproduct ID ,
12	bcdDevice	2	0x0001	Device release code
14	iManufacturer	1	0x01	“AKM”
15	iProduct	1	0x02	“AK5371”
16	iSerialNumber	1	0x00	Unused
17	bNumConfigurations	1	0x01	One configuration

2 Configuration Descriptor

The configuration block consists of a configuration descriptor followed by interface, endpoint, and class-specific descriptors.

Offset	Field	Size	Value	Description
0	bLength	1	0x09	Size of this descriptor
1	bDescriptorType	1	0x02	CONFIGURATION descriptor
2	wTotalLength	2	0x00B1	Length of entire configuration block Total 177 bytes including this interface descriptor.
4	bNumInterfaces	1	0x02	Two interfaces
5	bConfigurationValue	1	0x01	Index of this configuration
6	iConfiguration	1	0x00	Null string
7	bmAttributes	1	0x80	Bus Powered Device
8	MaxPower	1	0x2D	Power consumption: 90mA

3 Interface Descriptor

3.1 Standard Audio Control Interface descriptor

3.1.1 This descriptor describes a standard interface which includes USB class code and the index to class-specific information.

Offset	Field	Size	Value	Description
0	bLength	1	0x09	Size of this descriptor
1	bDescriptorType	1	0x04	INTERFACE descriptor
2	bInterfaceNumber	1	0x00	Index of this interface
3	bAlternateSetting	1	0x00	Index of this setting
4	bNumEndpoints	1	0x00	Endpoint 0
5	bInterfaceClass	1	0x01	AUDIO
6	bInterfaceSubclass	1	0x01	AUDIO_CONTROL
7	bInterfaceProtocol	1	0x00	Unused
8	iInterface	1	0x00	null string

3.2 Class-specific Audio Control Interface

3.3 Class-specific Audio Control Interface Header Descriptor

3.3.1 Contains general information about the audio device.

Offset	Field	Size	Value	Description
0	bLength	1	0x09	Size of this descriptor
1	bDescriptorType	1	0x24	CS_INTERFACE
2	bDescriptorSubtype	1	0x01	HEADER subtype
3	bcdADC	2	0x0100	Revision of class specification – 1.0
5	wTotalLength	2	0x0028	Total size of class-specific Audio Control Interface descriptors (includes this descriptor)
7	bInCollection	1	0x01	Number of streaming interfaces
8	baInterfaceNr(1)	1	0x01	Streaming interface number 1 belongs to this audio control interface.

3.3.2 Input terminal descriptor

This descriptor describes the signal coming through the input port NumChannels is 1(monaural) and ChannelConfig is set no position. Terminal type is Microphone.

Offset	Field	Size	Value	Description
0	bLength	1	0x0C	Size of this descriptor
1	bDescriptorType	1	0x24	CS_INTERFACE
2	bDescriptorSubtype	1	0x02	INPUT_TERMINAL subtype
3	bTerminalID	1	0x01	ID of this terminal
4	wTerminalType	2	0x0201	Terminal is Microphone
6	bAssocTerminal	1	0x02	ID of associated Output Terminal is 0x02
7	bNrChannels	1	0x02	Two channels (Stereo)
8	wChannelConfig	2	0x0003	Left/Right Front
10	iChannelNames	1	0x00	Unused
11	iTerminal	1	0x00	Unused

3.3.3 Output terminal descriptor

This descriptor describes the USB stream to host.

Offset	Field	Size	Value	Description
0	bLength	1	0x09	Size of this descriptor
1	bDescriptorType	1	0x24	CS_INTERFACE
2	bDescriptorSubtype	1	0x03	OUTPUT_TERMINAL subtype
3	bTerminalID	1	0x02	ID of this terminal
4	wTerminalType	2	0x0101	USB Streamer
6	bAssocTerminal	1	0x01	ID of associate Input Terminal is 0x01
7	bSourceID	1	0x03	From Feature Unit
8	iTerminal	1	0x00	Unused

3.3.4 Feature Unit descriptor

Offset	Field	Size	Value	Description
0	bLength	1	0x0A	Size of this descriptor
1	bDescriptorType	1	0x24	CS_INTERFACE
2	bDescriptorSubtype	1	0x06	FEATURE_UNIT descriptor subtype
3	bUnitID	1	0x03	ID of this feature Unit
4	bSourceID	1	0x01	ID to Terminal to which this is connected.
5	bControlSize	1	0x01	Size in bytes of an element of the bmaControl()
6	bmaControls(0)	1	0x01	D0(Mute) is enable for Channel 0
7	bmaControls(1)	1	0x02	D1(Volume) is enable for ch 1(Left)
8	bmaControls(2)	1	0x02	D1(Volume) is enable for ch 2 (Right)
9	iFeature	1	0x00	Unused

Note that there is never endpoint descriptor for endpoint 0.

3.4 Audio streaming interface

3.4.1 Zero bandwidth interface descriptor

Offset	Field	Size	Value	Description
0	bLength	1	0x09	Length of this descriptor
1	bDescriptorType	1	0x04	INTERFACE descriptor
2	bInterfaceNumber	1	0x01	Index of this interface
3	bAlternateSetting	1	0x00	Index of this setting
4	bNumEndpoints	1	0x00	Endpoints 0
5	bInterfaceClass	1	0x01	AUDIO
6	bInterfaceSubclass	1	0x02	AUDIO_STREAMING
7	bInterfaceProtocol	1	0x00	Unused
8	iInterface	1	0x00	null string

3.4.2 Interface descriptor(Alt = 1, 16bit Mono)

Offset	Field	Size	Value	Description
0	bLength	1	0x09	Length of this descriptor
1	bDescriptorType	1	0x04	INTERFACE descriptor
2	bInterfaceNumber	1	0x01	Index of this interface
3	bAlternateSetting	1	0x01	Index of this setting
4	bNumEndpoints	1	0x01	Endpoint 1
5	bInterfaceClass	1	0x01	AUDIO
6	bInterfaceSubclass	1	0x02	AUDIO_STREAMING
7	bInterfaceProtocol	1	0x00	Unused
8	iInterface	1	0x00	null string

3.4.3 Class-specific audio streaming interface descriptor

Offset	Field	Size	Value	Description
0	bLength	1	0x07	Length of this descriptor
1	bDescriptorType	1	0x24	CS_INTERFACE descriptor
2	bDescriptorSubtype	1	0x01	AS_GENERAL
3	bTerminalLink	1	0x02	Unit ID of terminal(Output Terminal ID)
4	bDelay	1	0x01	Interface delay
5	wFormatTag	2	0x0001	PCM

3.4.4 Type I format type descriptor

Offset	Field	Size	Value	Description
0	blength	1	0x17	Size of this descriptor
1	bDescriptorType	1	0x24	CS_INTERFACE
2	bdescriptorSubtype	1	0x02	FORMAT_TYPE
3	bformatType	1	0x01	FORMAT_TYPE_I
4	bNrChannels	1	0x01	One channel
5	bSubFrameSize	1	0x02	Two bytes per slot
6	bBitResolution	1	0x10	16 bits
7	bSamFreqType	1	0x05	Five frequencies
8	tSamFreq[0]	3	0x001F40	8000Hz
11	tSamFreq[1]	3	0x002B11	11025Hz
14	tSamFreq[2]	3	0x005622	22050Hz
17	tSamFreq[3]	3	0x00AC44	44100Hz
20	tSamFreq[4]	3	0x00BB80	48000Hz

3.5 Endpoint descriptor

3.5.1 Standard Endpoint Descriptor

Offset	Field	Size	Value	Description
0	bLength	1	0x09	Length of this descriptor
1	bDescriptorType	1	0x05	ENDPOINT descriptor
2	bEndpointAddress	1	0x81	Endpoint 1, IN direction
3	bmAttributes	1	0x05	Isochronous, asynchronous, not shared
4	wMaxPacketSize	2	0x0064	2byte*50sample*1ch=100 byte/frame
6	wInterval	1	0x01	One packet every frame (Must be set to 1)
7	bRefresh	1	0x00	
8	bSynchAddress	1	0x00	

3.5.2 Class-specific isochronous audio data endpoint descriptor

Offset	Field	Size	Value	Description
0	bLength	1	0x07	Size of this descriptor
1	bDescriptorType	1	0x25	CS_ENDPOINT
2	bDescriptorSubtype	1	0x01	GENERAL
3	bmAttributes	1	0x01	Sample rate control
4	bLockDelayUnits	1	0x00	Unused
5	wLockDelay	2	0x0000	

3.5.3 Interface descriptor (Alt = 2, 16bit Stereo)

Offset	Field	Size	Value	Description
0	bLength	1	0x09	Length of this descriptor
1	bDescriptorType	1	0x04	INTERFACE descriptor
2	bInterfaceNumber	1	0x01	Index of this interface
3	bAlternateSetting	1	0x02	Index of this setting
4	bNumEndpoints	1	0x01	Endpoint 1
5	bInterfaceClass	1	0x01	AUDIO
6	bInterfaceSubclass	1	0x02	AUDIO_STREAMING
7	bInterfaceProtocol	1	0x00	Unused
8	iInterface	1	0x00	null string

3.5.4 Class-specific audio streaming interface descriptor

Offset	Field	Size	Value	Description
0	bLength	1	0x07	Length of this descriptor
1	bDescriptorType	1	0x24	CS_INTERFACE descriptor
2	bDescriptorSubtype	1	0x01	AS_GENERAL
3	bTerminalLink	1	0x02	Unit ID of terminal(Output Terminal ID)
4	bDelay	1	0x01	Interface delay
5	wFormatTag	2	0x0001	PCM

3.5.5 Type I format type descriptor

Offset	Field	Size	Value	Description
0	blength	1	0x17	Size of this descriptor
1	bDescriptorType	1	0x24	CS_INTERFACE
2	bdescriptorSubtype	1	0x02	FORMAT_TYPE
3	bformatType	1	0x01	FORMAT_TYPE_I
4	bNrChannels	1	0x02	Two channel
5	bSubFrameSize	1	0x02	Two bytes per slot
6	bBitResolution	1	0x10	16 bits
7	bSamFreqType	1	0x05	Five frequencies
8	tSamFreq[0]	3	0x001F40	8000Hz
11	tSamFreq[1]	3	0x002B11	11025Hz
14	tSamFreq[2]	3	0x005622	22050Hz
17	tSamFreq[3]	3	0x00AC44	44100Hz
20	tSamFreq[4]	3	0x00BB80	48000Hz

3.6 Endpoint descriptor

3.6.1 Standard Endpoint Descriptor

Offset	Field	Size	Value	Description
0	bLength	1	0x09	Length of this descriptor
1	bDescriptorType	1	0x05	ENDPOINT descriptor
2	bEndpointAddress	1	0x81	Endpoint 1, IN direction
3	bmAttributes	1	0x05	Isochronous, asynchronous, not shared
4	wMaxPacketSize	2	0x00C8	2byte*50sample*2ch=200 byte/frame
6	wInterval	1	0x01	One packet every frame (Must be set to 1)
7	bRefresh	1	0x00	
8	bSynchAddress	1	0x00	

3.6.2 Class-specific isochronous audio data endpoint descriptor

Offset	Field	Size	Value	Description
0	bLength	1	0x07	Size of this descriptor
1	bDescriptorType	1	0x25	CS_ENDPOINT
2	bDescriptorSubtype	1	0x01	GENERAL
3	bmAttributes	1	0x01	Sample rate control
4	bLockDelayUnits	1	0x00	Unused
5	wLockDelay	2	0x0000	

4 Standard requests

4.1 Clear Feature

The AK5371 accepts “Clear Feature” request without stall. Though this request does not influence to the operation of the device, the AK5371 does not support this request.

4.2 Get Configuration

The AK5371 returns Configuration value.

Offset	Field	Size	Value	Description
0	bmRequestType	1	0x80	
1	bRequest	1	0x08	GET_CONFIGURATION
2	wValue	2	0x0000	
4	wIndex	2	0x0000	
6	wLength	2	0x0001	AKM USB Mic. has one configuration.

4.3 Get Descriptor

Offset	Field	Size	Value	Description
0	bmRequestType	1	0x80	
1	bRequest	1	0x06	GET_DESCRIPTOR
2	wValue	2	0xZZZZ	ZZZZ is assigned by host: High Byte is Descriptor Type, Low Byte is Index. DEVICE : 0x0100 : (Index is 0 only) CONFIGURATION : 0x0200 STRING: 0x03??(?? is 00, 01, 02)
4	wIndex	2	0x0000	if wValue is DEVICE or CONFIGURATION, wIndex is zero. If wValue is 0x0300(LANGID), wIndex is zero. If wValue is 0x0301 or 0x0302, wIndex is 0x0409“English(US)”.
6	wLength	2	0xZZZZ	Descriptor Length (ZZZZ is assigned by host)

4.4 Get Interface

The AK5371 returns the current bAlternateSetting value.

Offset	Field	Size	Value	Description
0	bmRequestType	1	0x81	
1	bRequest	1	0x0A	GET_INTERFACE
2	wValue	2	0x0000	ZERO
4	wIndex	2	0x0000 0x0001	Audio Control Interface Audio Streaming Interface
6	wLength	2	0x0001	AKM USB Mic. Has zero bandwidth Audio Streaming Interface and normal Audio Streaming Interface.

4.5 Get Status

Offset	Field	Size	Value	Description
0	bmRequestType	1	0x80 0x81 0x82	DEVICE INTERFACE ENDPOINT
1	bRequest	1	0x00	GET_STATUS
2	wValue	2	0x0000	ZERO
4	wIndex	2		
6	wLength	2	0x0002	

The AKM USB MIC returns the following status.

- a)Device : 0x00 (AKM USB MIC is bus-powered device)
- b)Interface: 0x00 (All Zero)
- c)Endpoint : 0x00

4.6 Set Address

AKM USB MIC stores the wValue in the internal memory as Device Address. In addition to this, the device returns ACK.

Offset	Field	Size	Value	Description
0	bmRequestType	1	0x00	Zero
1	bRequest	1	0x05	SET_ADDRESS
2	wValue	2	0xZZZZ	Device Address : ZZZZ is assigned by host
4	wIndex	2	0x0000	Zero
6	wLength	2	0x0000	Zero

4.7 Set Configuration

AKM USB MIC is placed to configured state only wValue of this request is 0x0001. In addition to this, the device returns ACK.

Offset	Field	Size	Value	Description
0	bmRequestType	1	0x00	Zero
1	bRequest	1	0x09	SET_CONFIGURATION
2	wValue	2	0x0000 0x0001 others	Unconfigured State AKM USB MIC is set to configured state Invalid
4	wIndex	2	0x0000	Zero
6	wLength	2	0x0000	Zero

4.8 Set Feature

The AK5371 accepts “Set Feature” request without stall. However note that the AK5371 does not support this request.

4.9 Set Interface

Audio format can be changed by the combination of Interface Number and Alternate Setting. Only 0x0000 is valid if wIndex is 0x0000

Offset	Field	Size	Value	Description
0	bmRequestType	1	0x01	ONE D7 0 = Host to device D6..5 0 = Standard request D4..0 1 = Recipient is interface
1	bRequest	1	0x0B	SET_INTERFACE
2	wValue	2	0x0000 0x0001 0x0002	Alternate Setting Control Interface or Zero Bandwidth 16bit Mono 16bit Stereo
4	wIndex	2	0x0000 0x0001	Audio Control Interface Audio Streaming Interface
6	wLength	2	0x0000	Zero

5 Device specific Requests

AKM USB Microphone supports ONLY SET_CUR as bRequest field in Set Request Values.

5.1 Audio Control Request

AKM USB microphone support ONLY Feature Unit Control Request, not support other requests. Addition to this, it only supports SET_CUR value as bRequest field in Set Feature Unit Control Request Values. All Audio Control Requests are applied to channel 0,1,2, which means master , left and right channel.

5.1.1 Set Feature Unit Control Request

AKM USB Microphone supports only one form of parameter block. Mute control is applied to master channel (channel 0)

a) Mute Control

Offset	Field	Size	Value	Description
0	bmRequestType	1	0x21	
1	bRequest	1	0x01	SET_CUR
2	wValue	2	0x0100	MUTE_CONTROL CHANNEL_0
4	wIndex	2	0x0300	Upper Byte : bUnit ID field in Feature Unit Descriptor.(0x03) Lower Byte : Audio Control Interface(0x00)
6	wLength	2	0x0001	The Length of Mute Control Parameter Block

The parameter block of mute control is the following.

Offset	Field	Size	Value	Description
0	bMute	1	0x01	TRUE
			0x00	FALSE

a) Volume Control

Left (channel 1) volume and right (channel 2) volume are controlled independently.

Offset	Field	Size	Value	Description
0	bmRequestType	1	0x21	
1	bRequest	1	0x01	SET_CUR
2	wValue	2	0x0201 0x0202	VOLUME_CONTROL CHANNEL_1 VOLUME_CONTROL CHANNEL_2
4	wIndex	2	0x0300	Upper Byte : bUnit ID field in Feature Unit Descriptor.(0x03) Lower Byte : Audio Control Interface(0x00)
6	wLength	2	0x0002	Volume Control

The parameter block of mute control is the following.

Offset	Field	Size	Value	Description
0	wVolume	2	0xZZZZ	The value is mapped to the volume register value. (refer to Table 1 conversion table) ZZZZ is assigned by the host

If the wVolume exceeds the range, the AK5371 forces the value into the range. Please see the conversion table in the Get Feature Unit Control Request.

5.1.2 Get Feature Unit Control Request

AKM USB Microphone supports only one form of parameter block.

a) Mute Control

Offset	Field	Size	Value	Description
0	bmRequestType	1	0xA1	
1	bRequest	1	0x81	GET_CUR
2	wValue	2	0x0100	MUTE_CONTROL CHANNEL_0
4	wIndex	2	0x0300	Upper Byte : bUnit ID field in Feature Unit Descriptor.(0x03) Lower Byte : Audio Control Interface(0x00)
6	wLength	2	0x0001	The Length of Mute Control Parameter Block

The device outputs the current setting of mute status.

Offset	Field	Size	Value	Description
0	bMute	1	0x01 0x00	TRUE FALSE

b) Volume Control

Offset	Field	Size	Value	Description
0	bmRequestType	1	0xA1	
1	bRequest	1	0x81 0x82 0x83 0x84	GET_CUR GET_MIN GET_MAX GET_RES
2	wValue	2	0x0201 0x0202	VOLUME_CONTROL CHANNEL_1 VOLUME_CONTROL CHANNEL_2
4	wIndex	2	0x0300	Upper Byte : bUnit ID field in Feature Unit Descriptor.(0x03) Lower Byte : Audio Control Interface(0x00)
6	wLength	2	0x0002	Volume Control

The parameter block of Volume Control is the following.

Offset	Field	Size	Value	Description
0	wVolume	2	0xZZYY 0xE100 0x1800 0x0100	bRequest = GET_CUR : returns current volume. YY must be 00h bRequest = GET_MIN : -31dB bRequest = GET_MAX : +24dB bRequest = GET_RES : 1.0dB

Table 1 is the conversion map of USB class and internal volume register.

When host requests the volume value which is larger than the MAX value in the device, the device is set the MAX value to the volume. When host requests the volume value which is smaller than the MIN value in the device, the device is set the MIN value to the volume. RES value is 1.0dB.

Field w Volume	Internal Value	value	Step
0x7FFF	0x1800	24.0000	1.0dB
-----	-----	-----	
0x1800	0x1800	24.0000	
0x17FF	0x1700	23.0000	
-----	-----	-----	
0x1701	0x1700	23.0000	
0x1700	0x1700	23.0000	
0x16FF	0x1600	22.0000	
-----	-----	-----	
0x1201	0x1200	18.0000	
0x1200	0x1200	18.0000	
-----	-----	-----	
-----	-----	-----	
0x02FF	0x0200	2.0000	
-----	-----	-----	
0x0201	0x0200	2.0000	
0x0200	0x0200	2.0000	
0x01FF	0x0100	1.0000	
-----	-----	-----	
0x0101	0x0100	1.0000	
0x0100	0x0100	1.0000	
0x00FF	0x0000	0.0000	
-----	-----	-----	
0x0001	0x0000	0.0000	
0x0000	0x0000	0.0000	
0xFFFF	0xFF00	-1.0000	
-----	-----	-----	
0xFF01	0xFF00	-1.0000	
0xFF00	0xFF00	-1.0000	
0xFEFF	0xFE00	-2.0000	
-----	-----	-----	
0xFE01	0xFE00	-2.0000	
0xFE00	0xFE00	-2.0000	
-----	-----	-----	
-----	-----	-----	
0xE200	0xE200	-30.0000	
0xE1FF	0xE100	-31.0000	
-----	-----	-----	
0xE101	0xE100	-31.0000	
0xE100	0xE100	-31.0000	
0xE1FF	0xE100	-31.0000	
-----	-----	-----	
0x8000	0xE100	-31.0000	

Table 1 Conversion Table of Volume Control

5.2 Endpoint Control Request

The AK5371 supports five sampling frequencies. The sampling rate is changed when “Set Endpoint Control Request” is issued. SET_CUR, GET_CUR of bRequest is only supported. GET_MIN, GET_MAX, and GET_RES of bRequest are not supported.

5.2.1 Set Endpoint Control Request

Offset	Field	Size	Value	Description
0	bmRequestType	1	0x22	
1	bRequest	1	0x01	SET_CUR
2	wValue	2	0x0100	Upper byte: SAMPLING_FREQ_CONTROL (0x01) Lower byte : zero
4	wIndex	2	0x0081	Upper Byte : zero Lower Byte : Endpoint Address (0x81)
6	wLength	2	0x0003	The Length of Sampling Frequency Parameter Block

The parameter block of mute control is the following.

Offset	Field	Size	Value	Description
0	iSampleFreq	3	0xYYYYYY	The following five values are valid. Others are invalid. 0x001F40 : 8kHz 0x002B11 : 11.025kHz 0x005622 : 22.05kHz 0x00AC44 : 44.1kHz(default) 0x00BB80 : 48kHz

If the iSampleFreq is different from the above values, the AK5371 forces sampling frequency to the appropriate value.

5.2.2 Get Endpoint Control Request

Offset	Field	Size	Value	Description
0	bmRequestType	1	0xA2	
1	bRequest	1	0x81	GET_CUR
2	wValue	2	0x0100	Upper byte: SAMPLING_FREQ_CONTROL (0x01) Lower byte : zero
4	wIndex	2	0x0081	Upper Byte : zero Lower Byte : Endpoint Address (0x81)
6	wLength	2	0x0003	The Length of Sampling Frequency Parameter Block

The parameter block of mute control is the following.

Offset	Field	Size	Value	Description
0	iSampleFreq	3	0xYYYYYY	The following five values are valid. Others are invalid. 0x001F40 : 8kHz 0x002B11 : 11.025kHz 0x005622 : 22.05kHz 0x00AC44 : 44.1kHz 0x00BB80 : 48kHz

Package(AK5371VQ)

48pin LQFP(Unit:mm)

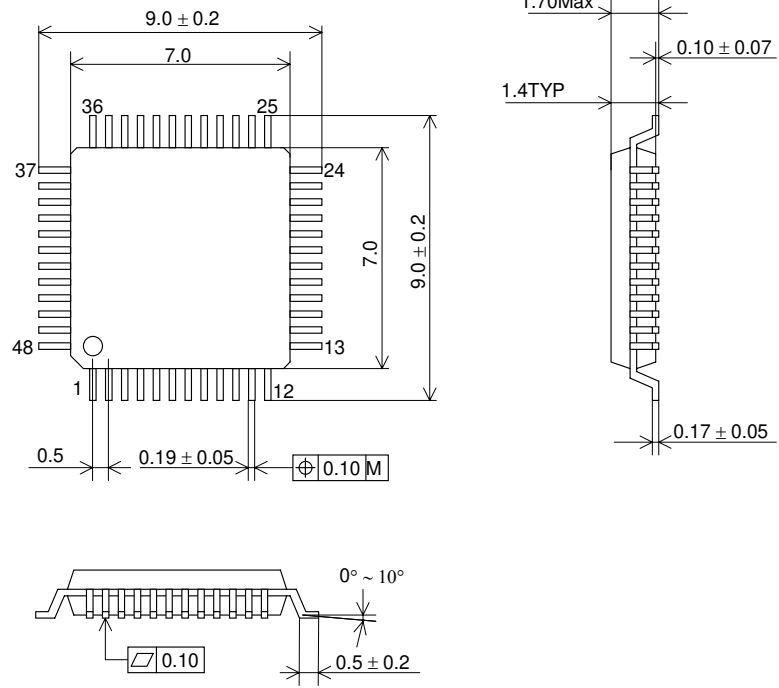

Marking(AK5371VQ)

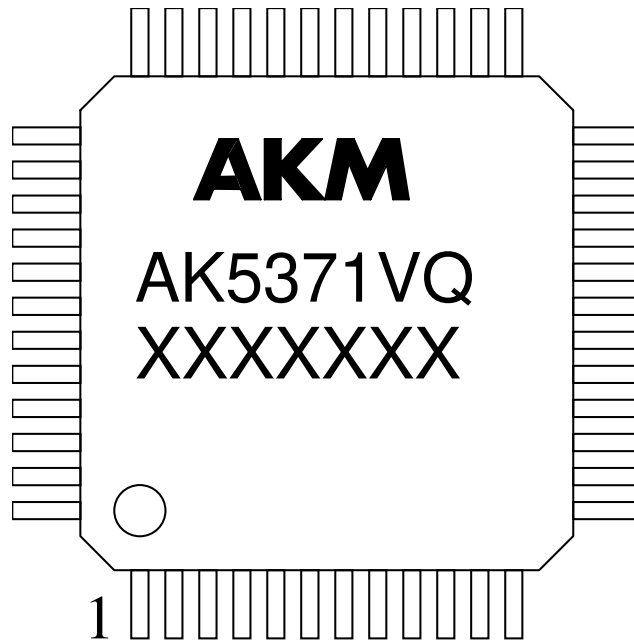

- 1) Pin #1 indication
- 2) Date Code: XXXXXXXX (7 digits)
- 3) Marking Code: AK5371VQ
- 4) Asahi Kasei Logo

Package (AK5371VN)

48pin QFN (Unit:mm)

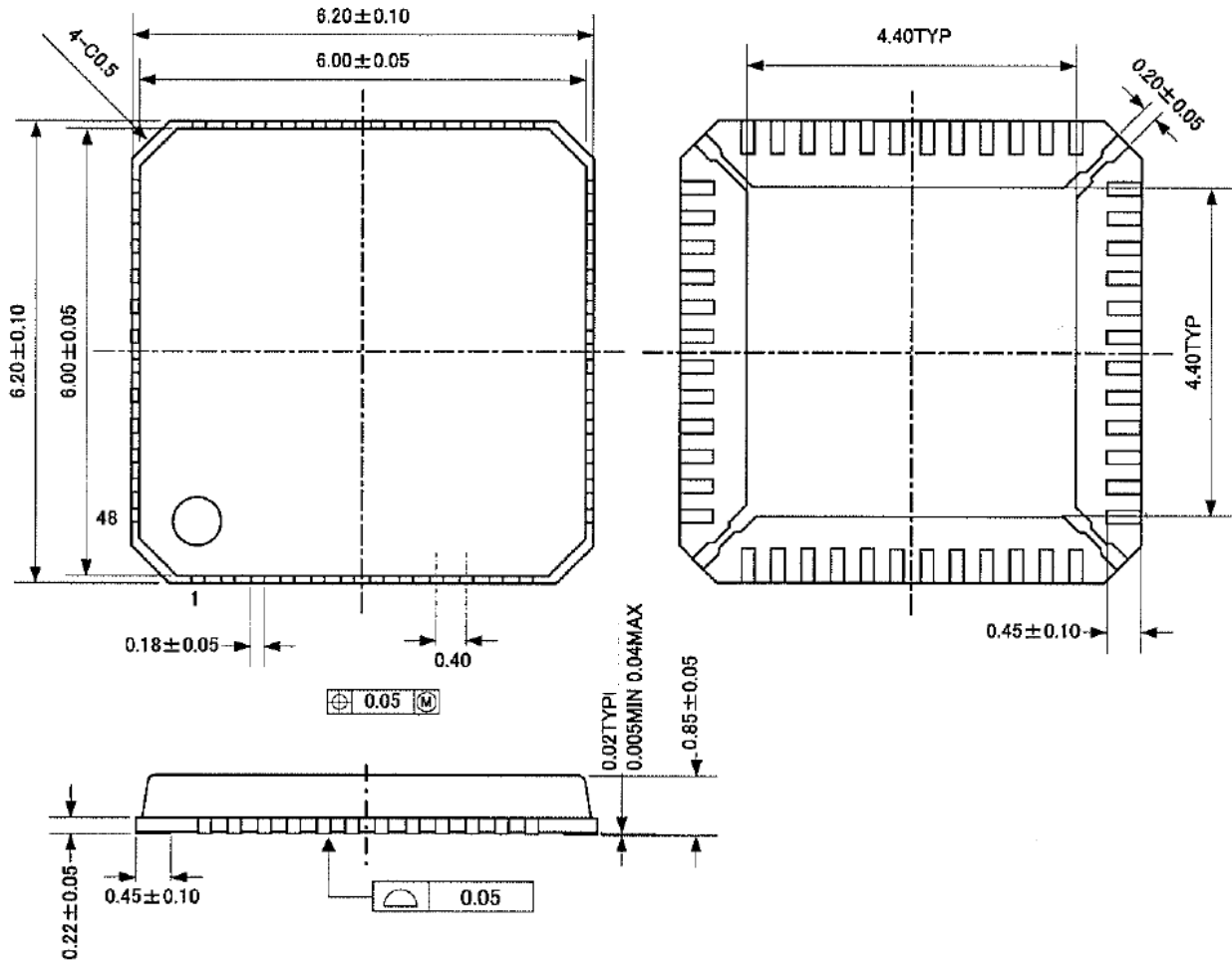

Marking(AK5371VN)

TBD

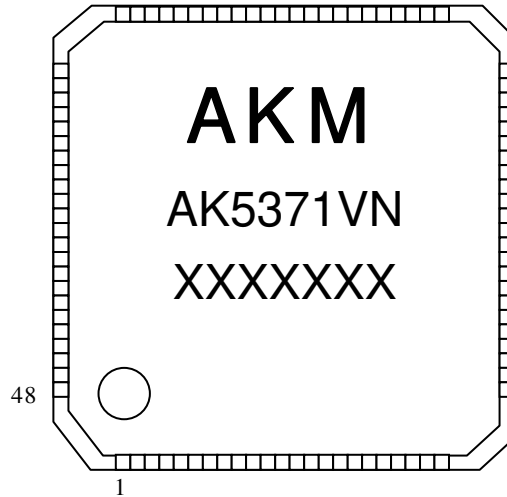

XXXXXXX: Date code identifier (7 digits)

IMPORTANT NOTICE

- These products and their specifications are subject to change without notice. Before considering any use or application, consult the Asahi Kasei Microsystems Co., Ltd. (AKM) sales office or authorized distributor concerning their current status.
- AKM assumes no liability for infringement of any patent, intellectual property, or other right in the application or use of any information contained herein.
- Any export of these products, or devices or systems containing them, may require an export license or other official approval under the law and regulations of the country of export pertaining to customs and tariffs, currency exchange, or strategic materials.
- AKM products are neither intended nor authorized for use as critical components in any safety, life support, or other hazard related device or system, and AKM assumes no responsibility relating to any such use, except with the express written consent of the Representative Director of AKM. As used here:
 - (a) A hazard related device or system is one designed or intended for life support or maintenance of safety or for applications in medicine, aerospace, nuclear energy, or other fields, in which its failure to function or perform may reasonably be expected to result in loss of life or in significant injury or damage to person or property.
 - (b) A critical component is one whose failure to function or perform may reasonably be expected to result, whether directly or indirectly, in the loss of the safety or effectiveness of the device or system containing it, and which must therefore meet very high standards of performance and reliability.
- It is the responsibility of the buyer or distributor of an AKM product who distributes, disposes of, or otherwise places the product with a third party to notify that party in advance of the above content and conditions, and the buyer or distributor agrees to assume any and all responsibility and liability for and hold AKM harmless from any and all claims arising from the use of said product in the absence of such notification.