

THIS DRAWING IS UNPUBLISHED. RELEASED FOR PUBLICATION
 © COPYRIGHT - By - ALL RIGHTS RESERVED.

LOC	DIST	REVISIONS					
G	14	P	LTR	DESCRIPTION	DATE	DWN	APVD
		E1		REVISED PER ECO-11-004917	11MAR11	RK	HMR

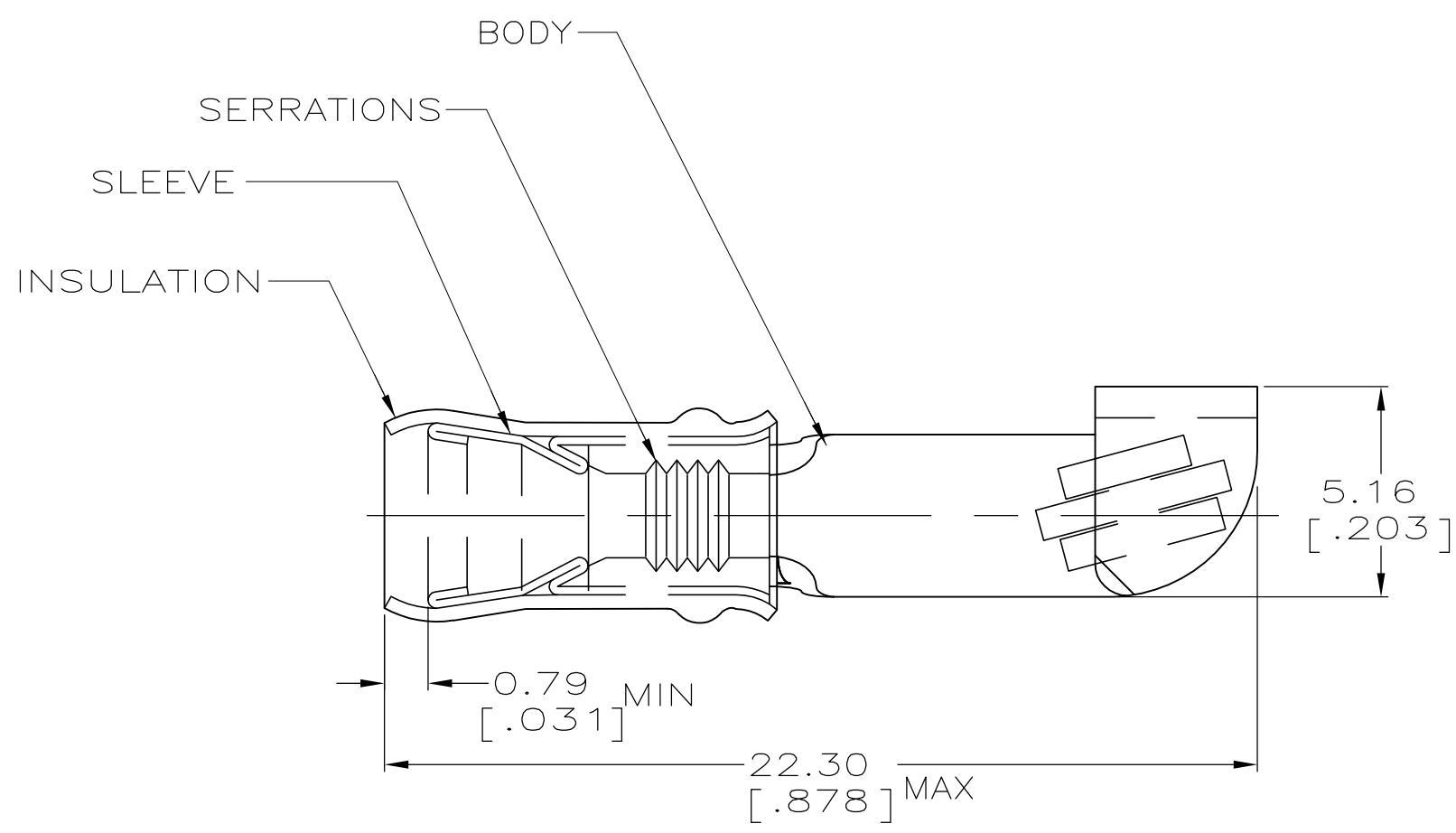

AMP WIRE RANGE	FILE E13288
STRANDED	STRANDED

- 1. STAMP AMP 22-18* 1-2 APPROX AS SHOWN
 22-16 TERMINALS ARE STAMPED 22-18 IN
 ACCORDANCE WITH MILITARY SPEC MIL-T-7928
 COMMERCIAL WIRE RANGE IS 22-16
- 2. WIRE INSUL DIA, 2.67-3.56 [.105-.140]
- 3. TONGUE MATL THK, 0.79±0.05 [.031±.002]

100	LOOSE PIECE, BOX	8-32446-1
5000	ON TAPE, REEL	2-32446-1
1000	LOOSE PIECE	32446
QTY	PACKAGE TYPE	PART NO

AMP INCORPORATED CUSTOMER SERVICE SYSTEM		MAX RECOMMENDED OPERATING TEMPERATURE: 105° C [221° F]	THIS DRAWING IS A CONTROLLED DOCUMENT.		DWN L OLMEDA 1DEC94	TE Connectivity NAME TERMINAL, KNIFE DISCONNECT, P.I.D.G., WIRE SIZE, 22-16 AWG				
FOR ADDITIONAL PRODUCT INFORMATION OR COPIES OF DRAWINGS AND TECHNICAL DOCUMENTS	PRODUCT INFORMATION CENTER 1-800-522-6752		VOLTAGE RATING: 300V MAX	DIMENSIONS: mm[INCHES]	TOLERANCES UNLESS OTHERWISE SPECIFIED:				CHK M ELLIS 1DEC94	APVD N BIRCH 1DEC94
FOR APPLICATION TOOLING INFORMATION	TOOLING ASSISTANCE CENTER 1-800-722-1111	CIRCULAR MIL AREA: 0.26mm ² -1.65mm ² [509-3260]			0 PLC ± - 1 PLC ± - 2 PLC ± 0.20 [.008] 3 PLC ± - 4 PLC ± - ANGLES ± -	PRODUCT SPEC	—	—	—	—
FOR ORDER ENTRY	1-800-526-5142		MATERIAL BODY, CU PER ASTM B152 INSUL, NYLON, RED SLV, CU PER ASTM B152	FINISH TIN PLATE PER MIL-T-10727	—	APPLICATION SPEC	—	—	—	—
CUSTOMER DRAWING					WEIGHT	—	A3	00779	C-32446	—
					SCALE	6:1	SHEET	1 OF 1	REV	E1