

Caracteristiques et matieres svt:
 Characteristics and materials:
 Caracteristicos y materias:

C28FC0031

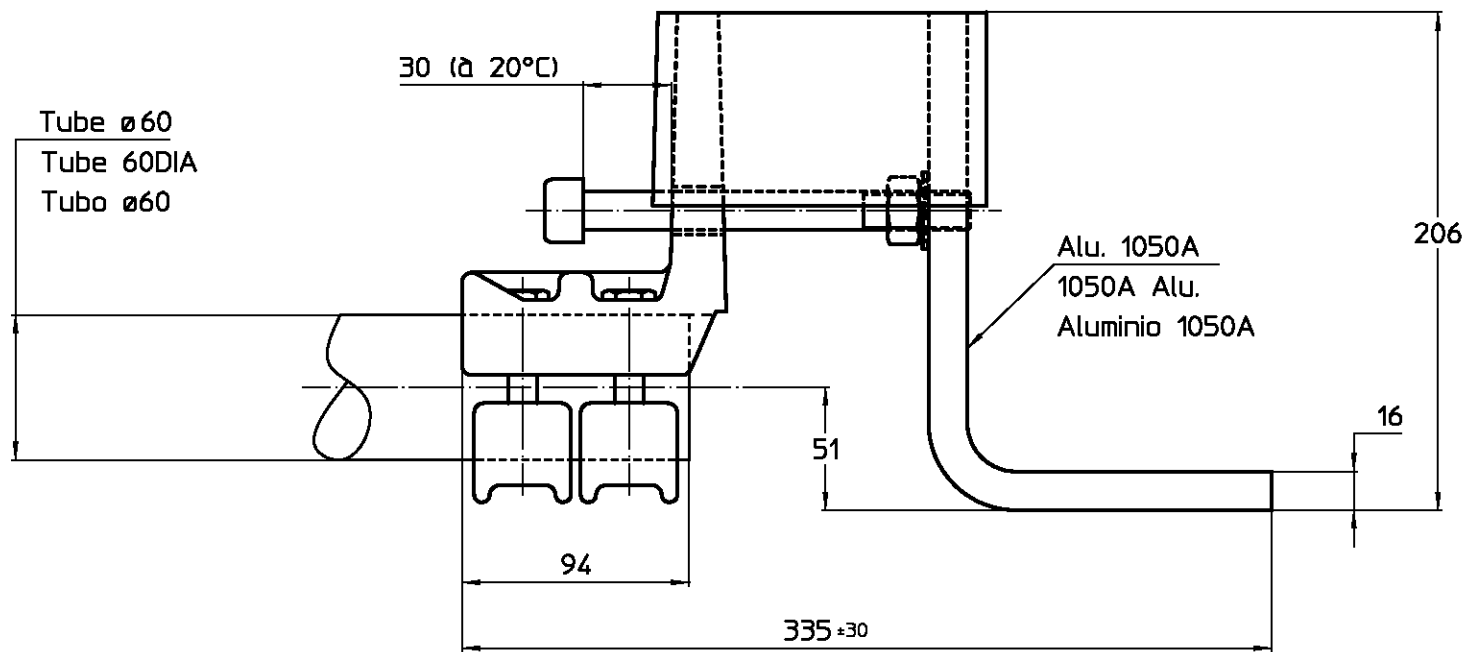

8 Lames 80x1 A5
 8 shunt 80x1 A5
 8 lâminas 80x1 A5

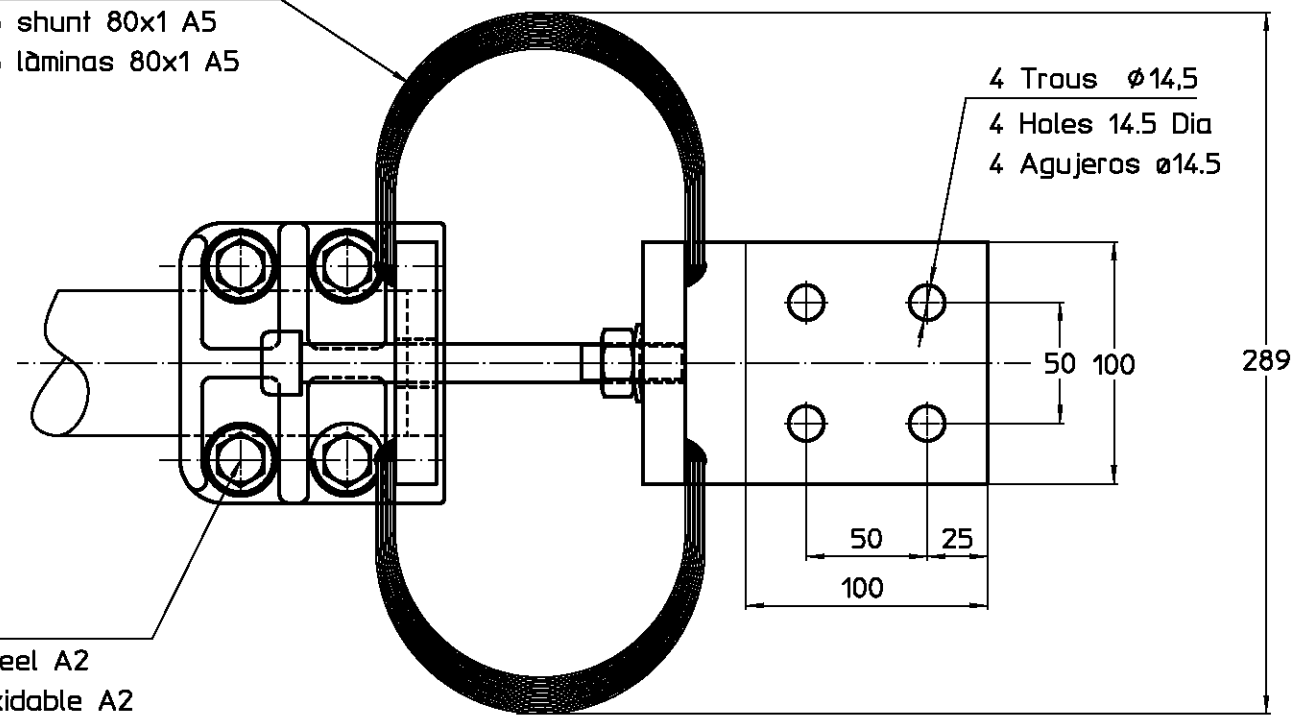

4 Boulons ø12 Inox A2
 4 Bolts 12DIA Stainless steel A2
 4 Tornillos ø12 Acero inoxidable A2

ITEM:

Specifications particulieres:
 Particular specifications:
 Especificacion particular:

Unites usuelles:
 Usual practical units:
 Unidades practicas usuales:

KG-MM-S-N

Masse:
 Mass:
 Masa: } 4.65 KG

a/FG0804

b/FG0267



Ref. CDS0 82 60 100 C257 S15

Ech 1/3 Code :
 Ceci est la propriété exclusive de SIMEL et ne peut être reproduit ni transmis sans notre autorisation écrite
 Simel 21220 Gevrey Chambertin - FRANCE

12/04/96 VOGEL
 Vérif: LAHAYE Appr: VIAL

Ancien No: 02VF01408
 C-793202