

QMT42 Series Fixed-Field Sensors



Datasheet

Sensing cutoff point at 500, 750, 1000, 1500, or 2000 millimeters (20, 30, 39, 59, or 79 inches)



- Fixed-field technology allows direct detection of objects within a defined sensing-field, while completely ignoring objects located beyond the sensing-field cutoff point
- Low-cost, compact, rugged sensors in metal die-cast housings
- Leakproof IP67 (NEMA 6) construction for reliable sensing in harsh environments
- Outstanding electrical noise immunity
- Dual LED system indicates sensor performance
- Choice of unterminated cable or quick-disconnect connector



WARNING: Not To Be Used for Personnel Protection

Never use this device as a sensing device for personnel protection. Doing so could lead to serious injury or death. This device does not include the self-checking redundant circuitry necessary to allow its use in personnel safety applications. A sensor failure or malfunction can cause either an energized or de-energized sensor output condition.

Models

Models	Sensing Cutoff Point	Cable	Output Type
QMT42VN6FF500	500 mm (20 in)	2 m (6.5 ft)	NPN
QMT42VN6FF500Q		4-pin Euro QD	
QMT42VP6FF500		2 m (6.5 ft)	PNP
QMT42VP6FF500Q		4-pin Euro QD	
QMT42VN6FF750	750 mm (30 in)	2 m (6.5 ft)	NPN
QMT42VN6FF750Q		4-pin Euro QD	
QMT42VP6FF750		2 m (6.5 ft)	PNP
QMT42VP6FF750Q		4-pin Euro QD	
QMT42VN6FF1000	1000 mm (39 in)	2 m (6.5 ft)	NPN
QMT42VN6FF1000Q		4-pin Euro QD	
QMT42VP6FF1000		2 m (6.5 ft)	PNP
QMT42VP6FF1000Q		4-pin Euro QD	
QMT42VN6FF1500	1500 mm (59 in)	2 m (6.5 ft)	NPN
QMT42VN6FF1500Q		4-pin Euro QD	
QMT42VP6FF1500		2 m (6.5 ft)	PNP
QMT42VP6FF1500Q		4-pin Euro QD	
QMT42VN6FF2000	2000 mm (79 in)	2 m (6.5 ft)	NPN
QMT42VN6FF2000Q		4-pin Euro QD	
QMT42VP6FF2000		2 m (6.5 ft)	PNP
QMT42VP6FF2000Q		4-pin Euro QD	



Fixed-Field Sensing – Theory of Operation

The QMT...FF... compares the reflections of its emitted light beam (E) from an object back to the sensor's two differently aimed detectors, R1 and R2. See [Figure 1](#) on page 2. If the near detector's (R1) light signal is stronger than the far detector's (R2) light signal (see object A in the Figure below, closer than the cutoff distance), the sensor responds to the object. If the far detector's (R2) light signal is stronger than the near detector's (R1) light signal (see object B in the Figure below, beyond the cutoff distance), the sensor ignores the object.

The cutoff distance for model QMT...FF... sensors is fixed at 500, 750, 1000, 1500, or 2000 millimeters (20, 30, 39, 59, or 79 inches). Objects lying beyond the cutoff distance are ignored, even if they are highly reflective. However, under certain conditions, it is possible to falsely detect a background object (see [Placement](#) on page 2).

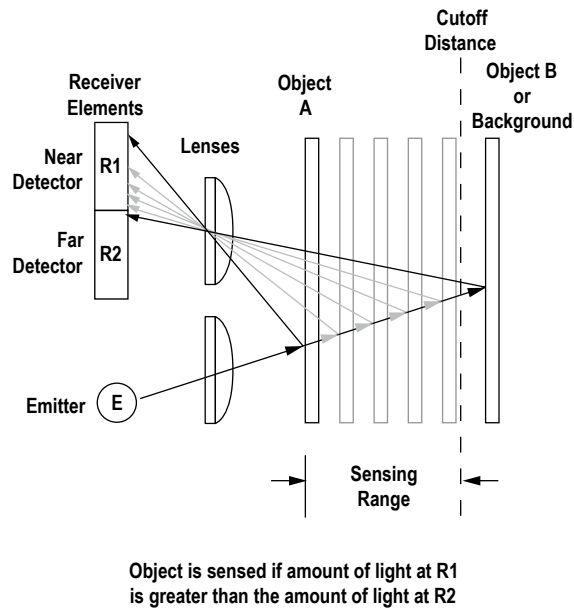

Figure 1. Fixed-Field Concept

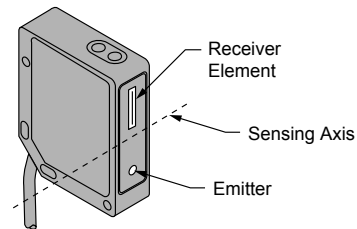
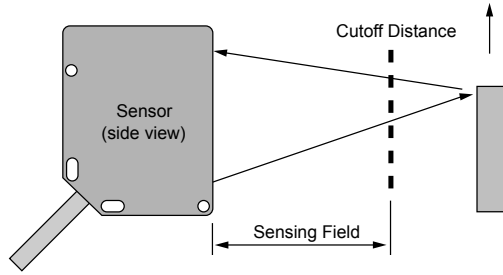

Figure 2. Fixed-Field Sensing Axis

In the drawings and information provided in this document, the letters E, R1, and R2 identify how the sensor's three optical elements (Emitter "E", Near Detector "R1", and Far Detector "R2") line up across the face of the sensor. The location of these elements defines the sensing axis, see [Figure 2](#) on page 2. The sensing axis becomes important in certain situations, such as those illustrated in [Figure 3](#) on page 3 and [Figure 4](#) on page 3.

Placement

An object beyond the cutoff distance, either stationary (and when positioned as shown in [Figure 3](#) on page 3), or moving past the face of the sensor in a direction perpendicular to the sensing axis, may cause unwanted triggering of the sensor if more light is reflected to the near detector than to the far detector. Correct the problem by rotating the sensor 90° ([Figure 4](#) on page 3). The object then reflects the R1 and R2 fields equally, resulting in no false triggering. A better solution, if possible, may be to reposition the object or the sensor.



A reflective background object in this position or moving across the sensor face in this axis and direction may cause a false sensor response.

Figure 3. Object Beyond Cutoff - Problem

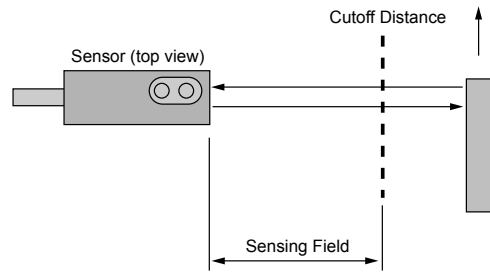

A reflective background object in this position or moving across the sensor face in this axis is ignored.

Figure 4. Object Beyond Cutoff - Solution

Specifications

Sensing Beam

Infrared, 880 nm

Supply Voltage and Current

10 to 30 V dc (10% max. ripple) at less than 40 mA

Supply Protection Circuitry

Protected against reverse polarity and transient voltages

Output Configuration

SPDT (complementary) solid-state dc switch; choose NPN or PNP models

Light operate: N.O. output conducts when the sensor sees its own modulated light

Dark operate: N.C. output conducts when the sensor sees dark

Output Rating

100 mA maximum (each output)

OFF-state leakage current: < 5 microamps at 30 V dc

ON-state saturation voltage: < 1 V at 10 mA dc; < 1.5 V at 100 mA dc

Output Protection Circuitry

Protected against false pulse on power-up and continuous overload or short-circuit of outputs

Overload trip point \geq 150 mA, typical, at 20 °C

Output Response Time

1 millisecond on and off



NOTE: 100 millisecond delay on power-up; outputs are non-conducting during this time

Repeatability of Response

250 microseconds

Sensing Hysteresis

Less than 5% of cutoff distance - 2000 mm models

Less than 4% of cutoff distance - 1500 mm models

Less than 3% of cutoff distance - 1000 mm models

Less than 2% of cutoff distance - 750 mm models

Less than 1% of cutoff distance - 500 mm models

Cutoff Point Tolerance

\pm 10% of nominal cutoff distance

Range

50 mm (2.0 in) to cutoff point

10 mm (0.4 in) to 6 m (20 ft)

Indicators

Two LEDs: Green and Amber

Green on steady = power to sensor is ON

Green flashing = output is overloaded

Amber on steady = light is sensed; normally open output ON

Amber flashing = marginal excess gain (1-1.5x) in light condition

Construction

Housings are die-cast zinc alloy with black acrylic polyurethane finish; lenses are acrylic

Environmental Rating

IEC IP67

NEMA 6

Connections

2 m (6.5 ft) or 9 m (30 ft) attached cable, or 4-pin M12/Euro-style quick-disconnect fitting; cables for QD models are purchased separately

Operating Conditions

-20 °C to +55 °C (-4 °F to +131°F)

90% at +50 °C maximum relative humidity (non-condensing)

Required Overcurrent Protection



WARNING: Electrical connections must be made by qualified personnel in accordance with local and national electrical codes and regulations.

Overcurrent protection is required to be provided by end product application per the supplied table.

Overcurrent protection may be provided with external fusing or via Current Limiting, Class 2 Power Supply.

Supply wiring leads < 24 AWG shall not be spliced.

For additional product support, go to <http://www.bannerengineering.com>.

Supply Wiring	Required Overcurrent Protection
20	5.0 Amps
22	3.0 Amps
24	2.0 Amps
26	1.0 Amps
28	0.8 Amps
30	0.5 Amps

Certifications



Performance Curves

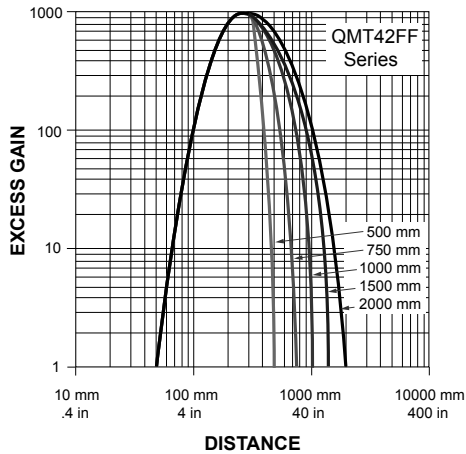

Cutoff Point Deviation

The percentage of deviation indicates a change in the cutoff point for either 18% gray or 6% black targets, relative to the cutoff point for a 90% reflective white test card. As an example, the cutoff point decreases 10% for a 6% reflectance black target when the cutoff point is 2000 millimeters (79 inches) using a 90% reflectance white test card. In other words, the cutoff point for the black target is 1800 millimeters (71 inches).

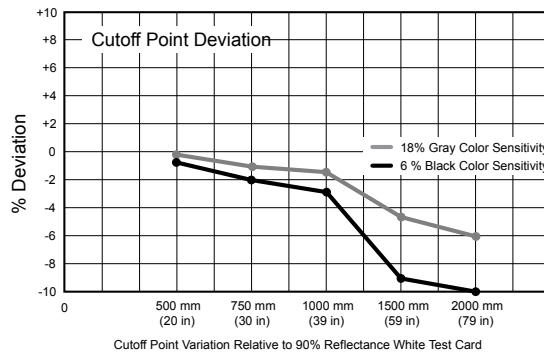

Dimensions

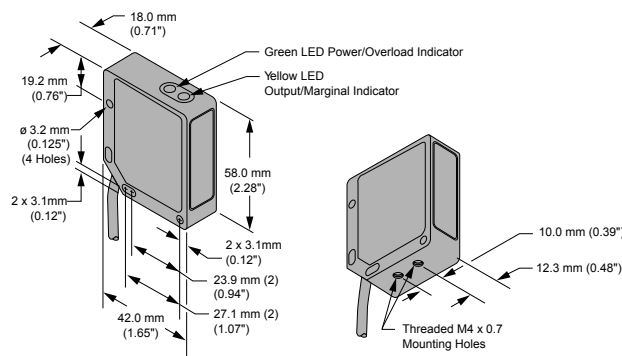

Figure 5. Cabled Models

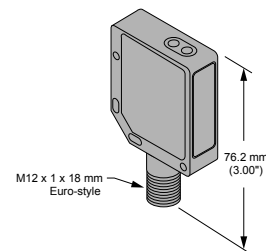
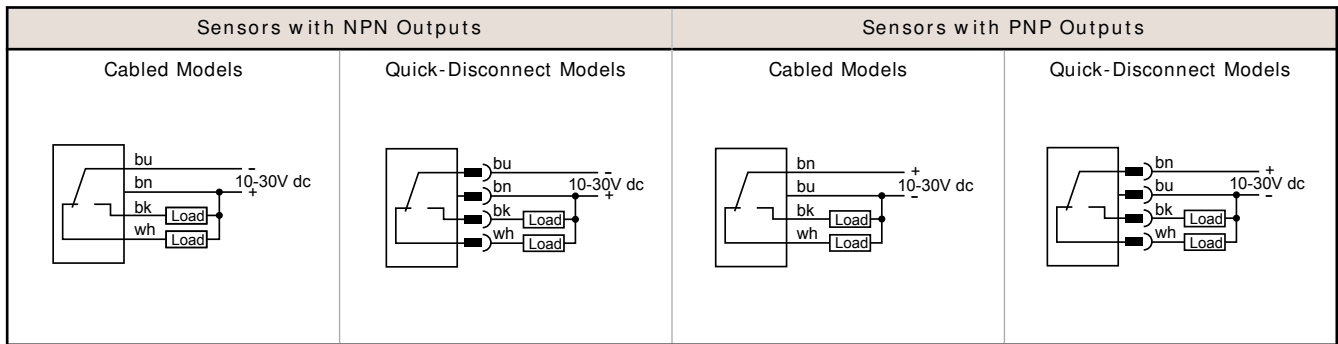

Figure 6. Quick-Disconnect Models

All measurements are listed in millimeters (inches), unless noted otherwise.

Wiring



Accessories

Quick-Disconnect (QD) Cables

4-Pin Threaded M12/ Euro-Style Cordsets				
Model	Length	Style	Dimensions	Pinout (Female)
MQDC-406	1.83 m (6 ft)	Straight		<p>1 = Brown 2 = White 3 = Blue 4 = Black</p>
MQDC-415	4.57 m (15 ft)			
MQDC-430	9.14 m (30 ft)			
MQDC-450	15.2 m (50 ft)			
MQDC-406RA	1.83 m (6 ft)	Right-Angle		
MQDC-415RA	4.57 m (15 ft)			
MQDC-430RA	9.14 m (30 ft)			
MQDC-450RA	15.2 m (50 ft)			

Mounting Brackets

SMB42T

- Stainless steel 2-axis side-mounting bracket
- Nut strap included for replacing two M3 mounting nuts

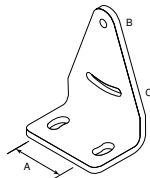

Hole center spacing: A = 20.3, B to C = 24.1

Hole size: A = ϕ 4.3 \times 20°, B = ϕ 3.0, C = ϕ 3.0 \times 30°

SMB42L

- 13-ga. stainless steel
- Hardware included

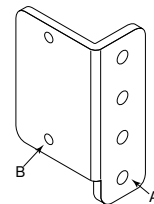

Hole center spacing: A = 10.0, B = 25.4

Hole size: A = ϕ 3.4, B = ϕ 2.5

SMB42F

- 13-ga. stainless steel
- Hardware included

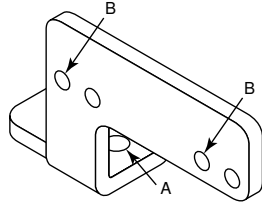

Hole center spacing: A = 10.0, B = 25.4

Hole size: A = \varnothing 3.4, B = \varnothing 2.5

SMB42U

- 13-ga. stainless steel
- Hardware included

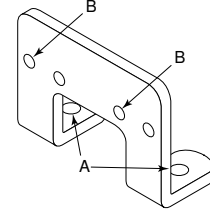

Hole center spacing: A = 30.0, B = 25.4

Hole size: A = \varnothing 3.4, B = \varnothing 2.5

Banner Engineering Corp. Limited Warranty

Banner Engineering Corp. warrants its products to be free from defects in material and workmanship for one year following the date of shipment. Banner Engineering Corp. will repair or replace, free of charge, any product of its manufacture which, at the time it is returned to the factory, is found to have been defective during the warranty period. This warranty does not cover damage or liability for misuse, abuse, or the improper application or installation of the Banner product.

THIS LIMITED WARRANTY IS EXCLUSIVE AND IN LIEU OF ALL OTHER WARRANTIES WHETHER EXPRESS OR IMPLIED (INCLUDING, WITHOUT LIMITATION, ANY WARRANTY OF MERCHANTABILITY OR FITNESS FOR A PARTICULAR PURPOSE), AND WHETHER ARISING UNDER COURSE OF PERFORMANCE, COURSE OF DEALING OR TRADE USAGE.

This Warranty is exclusive and limited to repair or, at the discretion of Banner Engineering Corp., replacement. IN NO EVENT SHALL BANNER ENGINEERING CORP. BE LIABLE TO BUYER OR ANY OTHER PERSON OR ENTITY FOR ANY EXTRA COSTS, EXPENSES, LOSSES, LOSS OF PROFITS, OR ANY INCIDENTAL, CONSEQUENTIAL OR SPECIAL DAMAGES RESULTING FROM ANY PRODUCT DEFECT OR FROM THE USE OR INABILITY TO USE THE PRODUCT, WHETHER ARISING IN CONTRACT OR WARRANTY, STATUTE, TORT, STRICT LIABILITY, NEGLIGENCE, OR OTHERWISE.

Banner Engineering Corp. reserves the right to change, modify or improve the design of the product without assuming any obligations or liabilities relating to any product previously manufactured by Banner Engineering Corp.

Copyright Notice

Any misuse, abuse, or improper application or installation of this product or use of the product for personal protection applications when the product is identified as not intended for such purposes will void the product warranty. Any modifications to this product without prior express approval by Banner Engineering Corp will void the product warranties. All specifications published in this document are subject to change; Banner reserves the right to modify product specifications or update documentation at any time. For the most recent version of any documentation, refer to: www.bannerengineering.com. © Banner Engineering Corp. All rights reserved.