



## 3.3V CMOS 16-BIT TRANSPARENT LATCH

**IDT74FCT163373A/C**

### FEATURES:

- 0.5 MICRON CMOS Technology
- Typical  $t_{sk(o)}$  (Output Skew) < 250ps
- ESD > 2000V per MIL-STD-883, Method 3015; > 200V using machine model (C = 200pF, R = 0)
- $V_{cc} = 3.3V \pm 0.3V$ , Normal Range, or  $V_{cc} = 2.7V$  to  $3.6V$ , Extended Range
- CMOS power levels (0.4 $\mu$  W typ. static)
- Rail-to-rail output swing for increased noise margin
- Low Ground Bounce (0.3V typ.)
- Inputs (except I/O) can be driven by 3.3V or 5V components
- Available in SSOP and TSSOP packages

### DESCRIPTION:

The FCT163373 16-bit transparent D-type latches are built using advanced dual metal CMOS technology. These high-speed, low-power latches are ideal for temporary storage of data. They can be used for implementing memory address latches, I/O ports, and bus drivers. The Output Enable and Latch Enable controls are organized to operate each device as two 8-bit latches or one 16-bit latch. Flow-through organization of signal pins simplifies layout. All inputs are designed with hysteresis for improved noise margin.

The inputs of FCT163373 can be driven from either 3.3V or 5V devices. This feature allows the use of these transparent latches as translators in a mixed 3.3V/5V supply system. With xLE inputs high, the FCT163373 can be used as a buffer to connect 5V components to a 3.3V bus.

### FUNCTIONAL BLOCK DIAGRAM

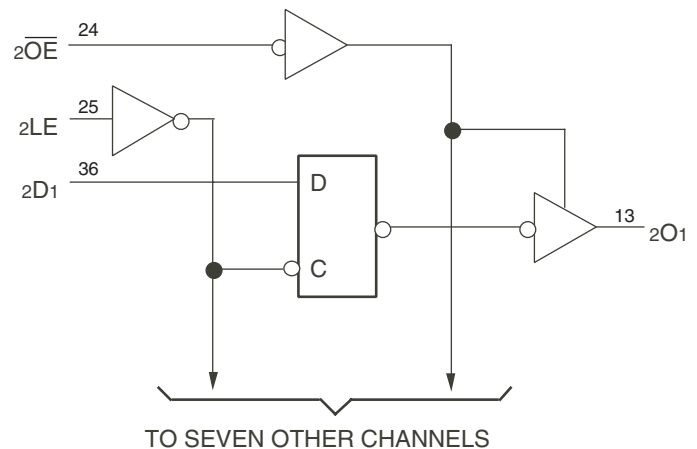
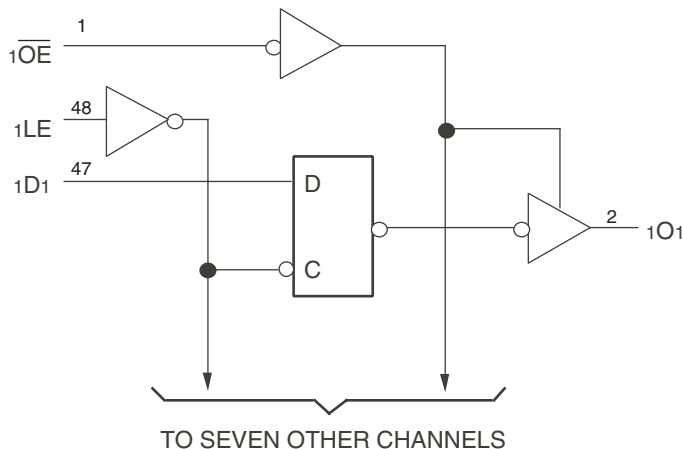

The IDT logo is a registered trademark of Integrated Device Technology, Inc.

**INDUSTRIAL TEMPERATURE RANGE**

**SEPTEMBER 2009**

## PIN CONFIGURATION

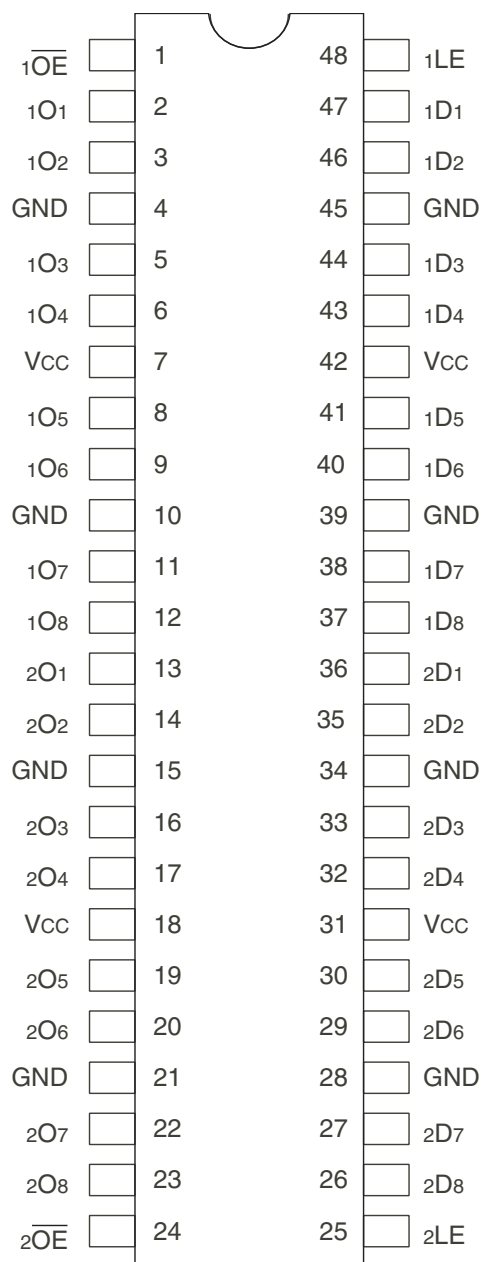

SSOP/ TSSOP  
TOP VIEW

## ABSOLUTE MAXIMUM RATINGS<sup>(1)</sup>

Symbol	Description	Max	Unit
VTERM <sup>(2)</sup>	Terminal Voltage with Respect to GND	-0.5 to +4.6	V
VTERM <sup>(3)</sup>	Terminal Voltage with Respect to GND	-0.5 to 7	V
VTERM <sup>(4)</sup>	Terminal Voltage with Respect to GND	-0.5 to VCC+0.5	V
TSTG	Storage Temperature	-65 to +150	°C
IOUT	DC Output Current	-60 to +60	mA

### NOTES:

- Stresses greater than those listed under ABSOLUTE MAXIMUM RATINGS may cause permanent damage to the device. This is a stress rating only and functional operation of the device at these or any other conditions above those indicated in the operational sections of this specification is not implied. Exposure to absolute maximum rating conditions for extended periods may affect reliability.
- Vcc terminals.
- Input terminals.
- Outputs and I/O terminals.

## CAPACITANCE (TA = +25°C, F = 1.0MHz)

Symbol	Parameter <sup>(1)</sup>	Conditions	Typ.	Max.	Unit
CIN	Input Capacitance	VIN = 0V	3.5	6	pF
COU	Output Capacitance	VOU = 0V	3.5	8	pF

### NOTE:

- This parameter is measured at characterization but not tested.

## PIN DESCRIPTION

Pin Names	Description
xDx	Data Inputs
xLE	Latch Enable Input (Active HIGH)
xOE	Output Enable Input (Active LOW)
xOx	3-State Outputs

## FUNCTION TABLE<sup>(1)</sup>

Inputs			Outputs
xDx	xLE	xOE	xBx
H	H	L	H
L	H	L	L
X	L	L	O <sup>(2)</sup>
X	X	H	Z

### NOTES:

- H = HIGH Voltage Level  
L = LOW Voltage Level  
X = Don't Care  
Z = High-Impedance
- Output level before the indicated steady-state input conditions were established.

## DC ELECTRICAL CHARACTERISTICS OVER OPERATING RANGE

Following Conditions Apply Unless Otherwise Specified:

Industrial:  $T_A = -40^{\circ}\text{C}$  to  $+85^{\circ}\text{C}$ ,  $V_{CC} = 2.7\text{V}$  to  $3.6\text{V}$

Symbol	Parameter	Test Conditions <sup>(1)</sup>	Min.	Typ. <sup>(2)</sup>	Max.	Unit	
V <sub>IH</sub>	Input HIGH Level (Input pins)	Guaranteed Logic HIGH Level	2	—	5.5	V	
	Input HIGH Level (I/O pins)		2	—	V <sub>CC</sub> +0.5		
V <sub>IL</sub>	Input LOW Level (Input and I/O pins)	Guaranteed Logic LOW Level	-0.5	—	0.8	V	
I <sub>IH</sub>	Input HIGH Current (Input pins)	V <sub>CC</sub> = Max.	V <sub>I</sub> = 5.5V	—	—	μA	
	Input HIGH Current (I/O pins)						V <sub>I</sub> = V <sub>CC</sub>
I <sub>IL</sub>	Input LOW Current (Input pins)		V <sub>I</sub> = GND	—	—		
	Input LOW Current (I/O pins)						V <sub>I</sub> = GND
IOZH	High Impedance Output Current (3-State Output pins)	V <sub>CC</sub> = Max.	V <sub>O</sub> = V <sub>CC</sub>	—	—	μA	
IOZL			V <sub>O</sub> = GND	—	—		±1
V <sub>IK</sub>	Clamp Diode Voltage	V <sub>CC</sub> = Min., I <sub>IIN</sub> = -18mA	—	-0.7	-1.2	V	
IODH	Output HIGH Current	V <sub>CC</sub> = 3.3V, V <sub>IN</sub> = V <sub>IH</sub> or V <sub>IL</sub> , V <sub>O</sub> = 1.5V <sup>(3)</sup>	-36	-60	-110	mA	
IODL	Output LOW Current	V <sub>CC</sub> = 3.3V, V <sub>IN</sub> = V <sub>IH</sub> or V <sub>IL</sub> , V <sub>O</sub> = 1.5V <sup>(3)</sup>	50	90	200	mA	
V <sub>OH</sub>	Output HIGH Voltage	V <sub>CC</sub> = Min.	I <sub>OH</sub> = -0.1mA	V <sub>CC</sub> -0.2	—	V	
		V <sub>IN</sub> = V <sub>IH</sub> or V <sub>IL</sub>					I <sub>OH</sub> = -3mA
		V <sub>CC</sub> = 3V V <sub>IN</sub> = V <sub>IH</sub> or V <sub>IL</sub>	I <sub>OH</sub> = -8mA	2.4 <sup>(5)</sup>	3		—
V <sub>OL</sub>	Output LOW Voltage	V <sub>CC</sub> = Min. V <sub>IN</sub> = V <sub>IH</sub> or V <sub>IL</sub>	I <sub>OL</sub> = 0.1mA	—	—	0.2	
			I <sub>OL</sub> = 16mA	—	0.2	0.4	
			I <sub>OL</sub> = 24mA	—	0.3	0.55	
		V <sub>CC</sub> = 3V V <sub>IN</sub> = V <sub>IH</sub> or V <sub>IL</sub>	I <sub>OL</sub> = 24mA	—	0.3	0.5	
I <sub>OS</sub>	Short Circuit Current <sup>(4)</sup>	V <sub>CC</sub> = Max., V <sub>O</sub> = GND <sup>(3)</sup>	-60	-135	-240	mA	
V <sub>H</sub>	Input Hysteresis	—	—	150	—	mV	
ICCL ICCH IC CZ	Quiescent Power Supply Current	V <sub>CC</sub> = Max. V <sub>IN</sub> = GND or V <sub>CC</sub>	—	0.1	10	μA	

### NOTES:

1. For conditions shown as Min. or Max., use appropriate value specified under Electrical Characteristics for the applicable device type.
2. Typical values are at V<sub>CC</sub> = 3.3V, +25°C ambient.
3. Not more than one output should be shorted at one time. Duration of the test should not exceed one second.
4. This parameter is guaranteed but not tested.
5. V<sub>OH</sub> = V<sub>CC</sub>-0.6V at rated current.

## POWER SUPPLY CHARACTERISTICS

Symbol	Parameter	Test Conditions <sup>(1)</sup>		Min.	Typ. <sup>(2)</sup>	Max.	Unit
$\Delta I_{CC}$	Quiescent Power Supply Current TTL Inputs HIGH	V <sub>CC</sub> = Max. V <sub>IN</sub> = V <sub>CC</sub> - 0.6V <sup>(3)</sup>		—	2	30	μA
I <sub>CCD</sub>	Dynamic Power Supply Current <sup>(4)</sup>	V <sub>CC</sub> = Max. Outputs Open x $\overline{OE}$ = GND One Input Toggling 50% Duty Cycle	V <sub>IN</sub> = V <sub>CC</sub> V <sub>IN</sub> = GND	—	50	75	μA/ MHz
I <sub>C</sub>	Total Power Supply Current <sup>(6)</sup>	V <sub>CC</sub> = Max., Outputs Open f <sub>i</sub> = 10MHz 50% Duty Cycle x $\overline{OE}$ = GND xLE = V <sub>CC</sub> One Bit Toggling	V <sub>IN</sub> = V <sub>CC</sub> V <sub>IN</sub> = GND	—	0.5	0.8	mA
			V <sub>IN</sub> = V <sub>CC</sub> - 0.6V V <sub>IN</sub> = GND	—	0.5	0.8	
		V <sub>CC</sub> = Max., Outputs Open f <sub>i</sub> = 2.5MHz 50% Duty Cycle x $\overline{OE}$ = GND xLE = V <sub>CC</sub> Sixteen Bits Toggling	V <sub>IN</sub> = V <sub>CC</sub> V <sub>IN</sub> = GND	—	2	3 <sup>(5)</sup>	
			V <sub>IN</sub> = V <sub>CC</sub> - 0.6V V <sub>IN</sub> = GND	—	2	3.3 <sup>(5)</sup>	

### NOTES:

- For conditions shown as max. or min., use appropriate value specified under Electrical Characteristics for the applicable device type.
- Typical values are at V<sub>CC</sub> = 3.3V, +25°C ambient.
- Per TTL driven input; all other inputs at V<sub>CC</sub> or GND.
- This parameter is not directly testable, but is derived for use in Total Power Supply Calculations.
- Values for these conditions are examples of the I<sub>CC</sub> formula. These limits are guaranteed but not tested.
- I<sub>C</sub> = I<sub>QUIESCENT</sub> + I<sub>INPUTS</sub> + I<sub>DYNAMIC</sub>  
 $I_C = I_{CC} + DI_{CC} D_H N_T + I_{CCD} (f_{CP} N_{CP} / 2 + f_i N_i)$   
 I<sub>CC</sub> = Quiescent Current (I<sub>CC1</sub>, I<sub>CC2</sub> and I<sub>CC3</sub>)  
 ΔI<sub>CC</sub> = Power Supply Current for a TTL High Input  
 D<sub>H</sub> = Duty Cycle for TTL Inputs High  
 N<sub>T</sub> = Number of TTL Inputs at D<sub>H</sub>  
 I<sub>CCD</sub> = Dynamic Current Caused by an Input Transition Pair (HLH or LHL)  
 f<sub>CP</sub> = Clock Frequency for Register Devices (Zero for Non-Register Devices)  
 N<sub>CP</sub> = Number of Clock Inputs at f<sub>CP</sub>  
 f<sub>i</sub> = Input Frequency  
 N<sub>i</sub> = Number of Inputs at f<sub>i</sub>

## SWITCHING CHARACTERISTICS OVER OPERATING RANGE<sup>(1)</sup>

Symbol	Parameter	Condition <sup>(2)</sup>	FCT163373A		FCT163373C		Unit
			Min. <sup>(3)</sup>	Max.	Min. <sup>(3)</sup>	Max.	
t <sub>PLH</sub> t <sub>PHL</sub>	Propagation Delay xDx to xOx	CL = 50pF RL = 500Ω	1.5	5.2	1.5	4.2	ns
t <sub>PLH</sub> t <sub>PHL</sub>	Propagation Delay xLE to xOx		2	8.5	2	5.5	ns
t <sub>PZH</sub> t <sub>PZL</sub>	Output Enable Time		1.5	6.5	1.5	5.5	ns
t <sub>PHZ</sub> t <sub>PLZ</sub>	Output Disable Time		1.5	5.5	1.5	5	ns
t <sub>SU</sub>	Set-up Time HIGH or LOW, xDx to xLE		2	—	2	—	ns
t <sub>H</sub>	Hold Time HIGH or LOW, xDx to xLE		1.5	—	1.5	—	ns
t <sub>W</sub>	xLE Pulse Width HIGH		5	—	5	—	ns
t <sub>sk(o)</sub>	Output Skew <sup>(4)</sup>		—	0.5	—	0.5	ns

### NOTES:

1. Propagation Delays and Enable/Disable times are with V<sub>CC</sub> = 3.3V ±0.3V, Normal Range. For V<sub>CC</sub> = 2.7V to 3.6V, Extended Range, all Propagation Delays and Enable/Disable times should be degraded by 20%.
2. See test circuit and waveforms.
3. Minimum limits are guaranteed but not tested on Propagation Delays.
4. Skew between any two outputs, of the same package, switching in the same direction. This parameter is guaranteed by design.

## TEST CIRCUITS AND WAVEFORMS

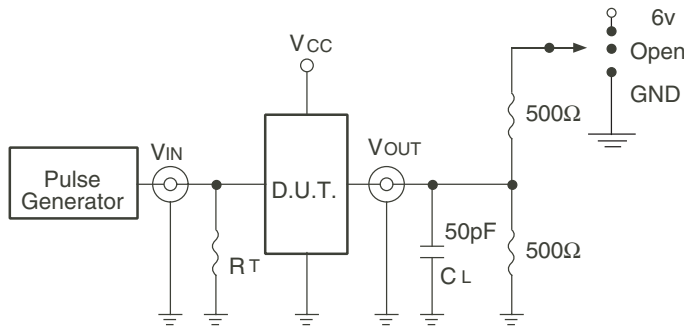

Test Circuits for All Outputs

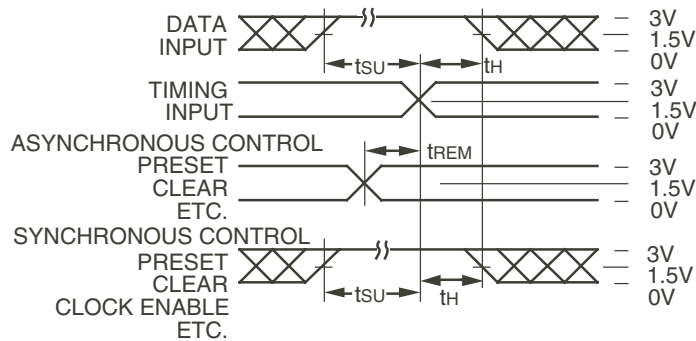

Set-up, Hold, and Release Times

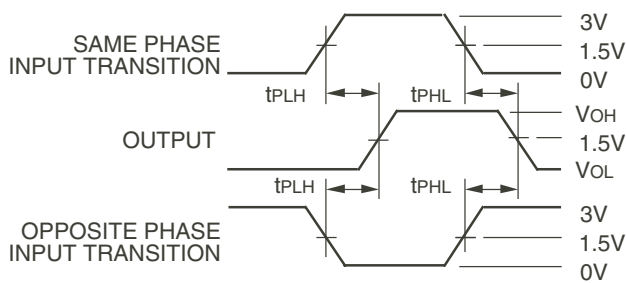

Propagation Delay

## SWITCH POSITION

Test	Switch
Open Drain Disable Low Enable Low	6V
Disable High Enable High	GND
All Other Tests	Open

### DEFINITIONS:

CL = Load capacitance: includes jig and probe capacitance.

RT = Termination resistance: should be equal to ZOUT of the Pulse Generator.

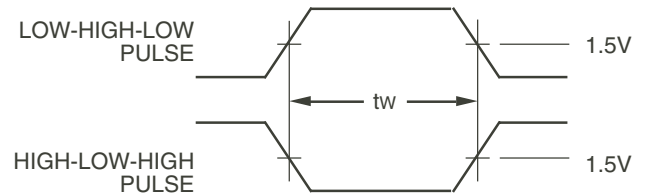

Pulse Width

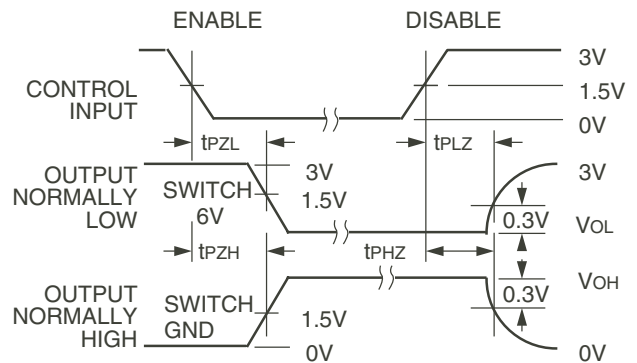

Enable and Disable Times

### NOTES:

1. Diagram shown for input Control Enable-LOW and input Control Disable-HIGH.
2. Pulse Generator for All Pulses: Rate  $\leq 1.0\text{MHz}$ ;  $t_r \leq 2.5\text{ns}$ ;  $t_f \leq 2.5\text{ns}$ .
3. If VCC is below 3V, input voltage swings should be adjusted not to exceed VCC.

## ORDERING INFORMATION

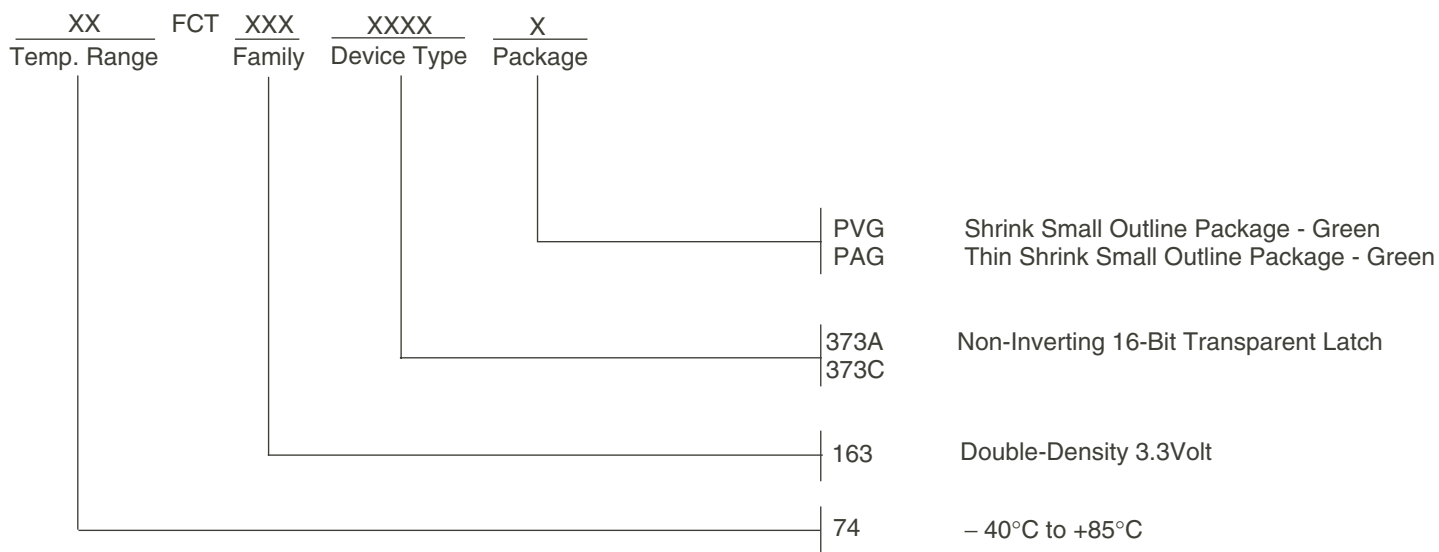

## Datasheet Document History

09/10/09 Pg.7 Updated the ordering information by removing the "IDT" notation and non RoHS part.



**CORPORATE HEADQUARTERS**  
6024 Silver Creek Valley Road  
San Jose, CA 95138

**for SALES:**  
800-345-7015 or 408-284-8200  
fax: 408-284-2775  
www.idt.com

**for Tech Support:**  
logichelp@idt.com