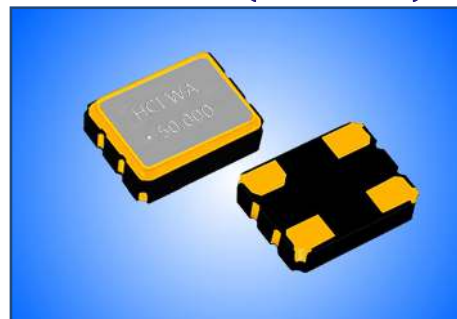

**VCXO UNIT WITH HCMOS OUTPUT IN SMD 3.2x2.5MM CERAMIC SEAM SEAL PACKAGE.**
**PRODUCT FEATURES**

- Small dimensions 3.2x2.5x1.0 with 4 solder pads.
- Tight stabilities over temperature range.
- RoHS compliant, LEAD-FREE, HALOGEN-FREE and REACH compliant.

**APPLICATIONS**

- WiMAX / WLAN / Ethernet
- DSL / VoIP
- Cable modem
- Set-top box / HDTV

**PRODUCT PHOTO (NOT IN SCALE)**

**PRODUCT SPECIFICATIONS**

PARAMETER	SUPPLY VOLTAGE			REMARKS
	1.8V	2.5V	3.3V	
Frequency range	15 ~ 50MHz	10 ~ 250MHz	10 ~ 250MHz	--
Frequency stability	±25ppm / ±50ppm / ±100ppm			See note below
Operating temperature range	-10 to +60°C / -20 to +70°C / -40 to +85°C			Options available
Aging first year	±3.0ppm			@+25°C
Frequency pulling range	±50ppm ~ ±200ppm			Depending on frequency
Supply current	40mA	45mA	50mA	@15pF
Output waveform and load	LVCMOS 15pF			30pF optional
Output voltage level HIGH	1.62V	2.25V	2.97V	Minimum
Output voltage level LOW	0.18V	0.25V	0.33V	Maximum
Rise and Fall times	6ns			@10~90% of V <sub>CC</sub>
Symmetry (duty cycle)	40~60% or 45~55%			@ 50%V <sub>CC</sub>
Phase jitter RMS	0.8 ~ 1ps			12kHz ≤ F <sub>j</sub> ≤ 20MHz
Phase noise (27MHz)	-132dBc			@ 1kHz
	-147dBc			@ 10kHz
	-152dBc			@ 100kHz

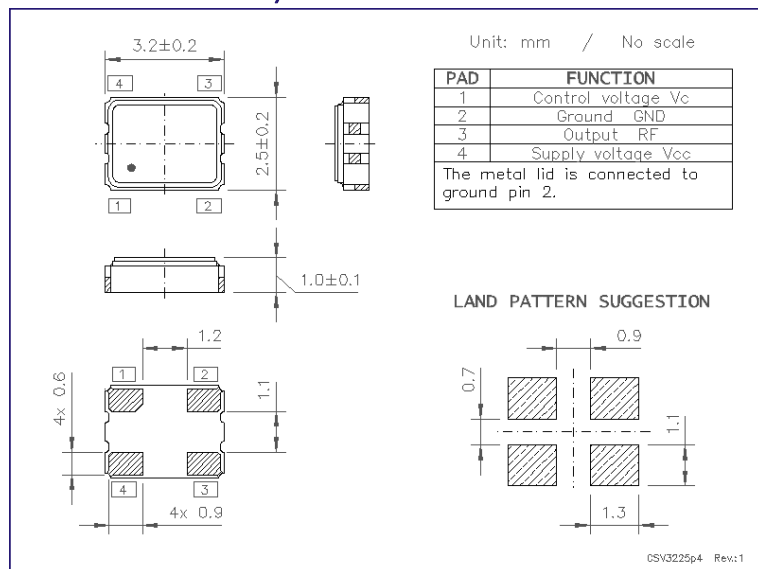
Note: Stability includes frequency deviations at +25°C, over temperature range, due to supply voltage changes, output load changes, shock and vibration.

**PACKAGE OUTLINE / DIMENSIONS**

**PACKAGING INFORMATION**

- Tape & Reel compliant to EIA-481.
- Embossed carrier width 8mm.
- Component pitch in carrier 4mm.
- Reel diameter 180mm.
- QTY per reel: 3,000pcs

**RECOMMENDED REFLOW PROFILE**
