

# USB SERIES

## CHOGORI

### USB Series Specifications

#### USB Series, Male Connector

##### Description

Field Installable, 180°  
Screw Type, Solder

Field Installable, 180°  
Lock Bayonet Type, Solder

##### Figure



##### Drawing

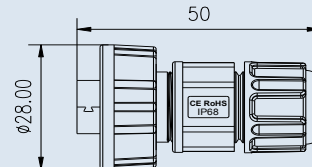
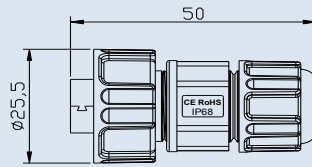

##### Part Number

Contacts	Cable Range(mm)	Part Number	Contacts	Cable Range(mm)	Part Number
4	3.5 - 6.8	34000000-01	4	3.5 - 6.8	34000000-02

##### Specifications

Number of Contacts	4
Wire Gauge	0.204mm <sup>2</sup> (24AWG)
Cable Range	3.5mm - 6.8mm
Environmental Protection	IP68
Mechanical Life	1500 mating cycles
Operating Temperature	- 45°C - +85°C
Breakdown Voltage	≥ AC 500V / 1Minute
Speed	480 Mbps
Contact Resistance	≤ 30mΩ Max
Insulation Resistance	≥ 1000MΩ Min
Rated Current (40°C)	1.5 A

# USB SERIES

## CHOGORI

### USB Series Specifications

#### USB Series, Panel Mount

Description

Panel Front Mount,  
Screw Type, PCB

Panel Front Mount,  
Lock Bayonet Type, PCB

Figure



Drawing

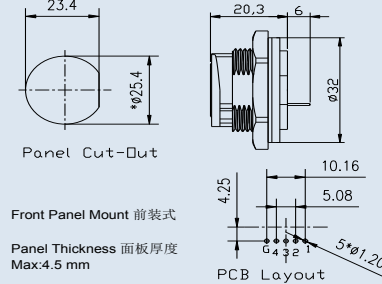
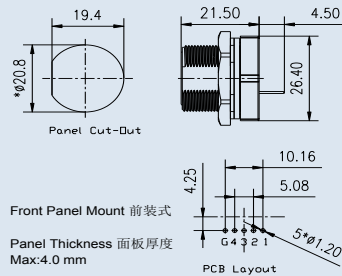

Part Number

Contacts	Part Number	Contacts	Part Number
4	34000000-03	4	34000000-04

Specifications

Number of Contacts	4	
Environmental Protection	IP68	IP67
Mechanical Life	1500 mating cycles	
Operating Temperature	- 45°C - 85°C	
Breakdown Voltage	≥ AC 500V / 1Minute	
Speed	480 Mbps	
Contact Resistance	≤ 30mΩ Max	
Insulation Resistance	≥ 1000MΩ Min	
Rated Current (40°C)	1.5 A	

# USB SERIES

## CHOGORI

### USB Series Specifications

#### USB Series, Panel Mount

Description

Panel Mount,  
Lock Type, PCB

Panel Mount,  
kirsite, PCB

Figure



Drawing

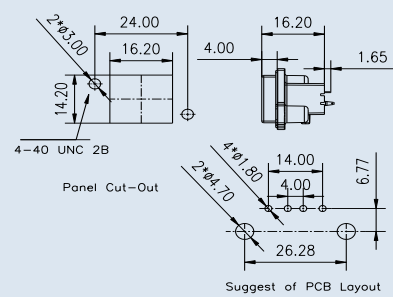
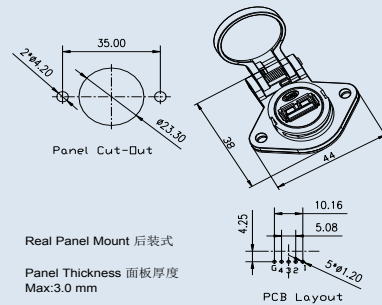

Part Number

Contacts	Part Number	Contacts	Part Number
4	34000000-05	4	34000000-06

Specifications

Number of Contacts	4	
Environmental Protection	IP67	IP67
Mechanical Life	1500 mating cycles	
Operating Temperature	- 45°C - 85°C	
Breakdown Voltage	≥ AC 500V / 1Minute	
Speed	480 Mbps	
Contact Resistance	≤30mΩ Max	
Insulation Resistance	≥1000MΩ Min	
Rated Current (40°C)	1.5 A	