

TABLE OF CONTENTS

CONTENTS	PAGE
----------	------

INTRODUCTION

Corporate Overview	2
Technology Overview	3
Specification Definitions	6
Thermal Considerations	11
Quality Assurance	12
MTBF Calculations	13
Manufacturing Flow Diagrams	14
Device 883 Screening	15
General Specifications	15
Space-Qualified Amplifiers	16

AFS AMPLIFIERS

Ultra-Wideband	21
Multi-octave	22
Octave Band	23
Moderate Band	24
Higher Power	28
Temperature Data	30

AFD AMPLIFIERS

Low-Noise	33
Higher Power	34
ULN, LN and MP Series	37

SPECIAL AMPLIFIER DESIGNS

AFS – Temperature Compensated	39
AFS – Cryogenic	40
AFS – Low Current Consumption	41
AFS – High Intercept	42
AFD – Limiting	43
AFSD/MPN – Medium Power	44

CONTENTS	PAGE
----------	------

SPECIAL AMPLIFIER DESIGNS (CONT)

AFSX – Coaxial In-Line	45
AFSB – Substrate	46
AFSM – Surface Mount	47
NSM – Connectorized/ Surface Mount	48
AFSW/AFTL – Pulse Modulated Power Gated	49
Power Monitoring Amplifiers	50
AVG – Variable Gain	51
ABIT – Built-In Test Detector	52
AFPD – Dual Output	53
NSP – Desktop	54
40 GHz Bias Tee and DC Block	55
Low Frequency Bias Tee Chassis	56
PS – Power Supply	57

GENERAL AMPLIFIER OPTIONS 57

OUTLINE DRAWINGS 58

ISO 9001:2000 71

ORDERING INFORMATION 71

WARRANTY 72

ADDITIONAL MITEQ PRODUCTS 73

FEDERAL SUPPLY CODE

Our Federal Supply Code is: 33592

INTRODUCTION

This catalog is intended to provide an overview of MITEQ's AFS/AFD Amplifier Department's standard products and custom capabilities. The products within this catalog are organized into three major sections:

- AFS amplifiers
- AFD amplifiers
- Special amplifier designs

In addition to these detailed products, we have included typical test data from some of our amplifiers to give you a feel for the performance listed in the specification tables. Also, included are technical notes and specification definitions written by our engineers to help in understanding our system design parameters. You may find these especially informative in assuring that your requirements are in line with the catalog

specifications.

To provide an overview of our manufacturing processes, we have included a section on quality assurance, manufacturing flow diagrams, and options available to the customer. In addition, we have documented reliability predictions for some of our typical amplifier models based upon these flow diagrams.

CUSTOM ENGINEERING

This catalog covers only a small percentage of designs available from MITEQ's AFS/AFD Department. For variations on catalog performance or custom designs, including both electrical and mechanical design efforts, please contact the factory for assistance.

CORPORATE OVERVIEW

MITEQ, an acronym for (M)icrowave (I)nformation (T)ransmission (EQ)uipment, designs and manufactures a complete line of high-performance components and subsystems for the microwave electronics community. Located on Long Island, New York for more than thirty years, it has grown into a company which is dedicated to achieving technical excellence, producing quality products and satisfying our customer's specific needs.

STANDARD PRODUCT LINES

MITEQ's product lines are basically split between two market segments:

- **Microwave components and integrated assemblies**
- **Satellite communications & earth station equipment**

The Microwave Component Division offers designs up to and over 60 GHz, including:

- **Amplifiers:** Moderate to broadband, ultralow-noise to medium-power, bipolar, and GaAs FET designs
- **Mixers:** Single-, double-, and triple-balanced, MESFET and Schottky mixers and low-noise receiver front ends
- **Frequency multipliers**
- **Passive power components**
- **Microwave assemblies, systems and technologies:** Solid-state switches, attenuators, and power dividers
- **RF and IF signal processing components**
- **Oscillators:** Crystal, voltage, cavity tuned, free-running, and phase-locked
- **Frequency synthesizers**
- **Integrated multifunction assemblies**
- **Fiber Optic products**

MITEQ's Satellite Communication and Earth Station Equipment Groups manufacture the following:

- **Up/downconverters**
- **Test translators**
- **IF/video equalizers**
- **Redundancy switchover units**
- **Video modulators and modems**

Specific products include synthesized converters with 1.0 kHz and 125 kHz frequency step sizes, INMARSAT L- and C-band converters, pilot generators and receivers, crystal controlled converters, video exciters, and custom designed products.

CUSTOM DESIGN CAPABILITIES

Although MITEQ offers one of the broadest lines of standard catalog items, the bulk of MITEQ's business is in customized components, assemblies, and systems designed specifically around the customer's needs. MITEQ's heavy emphasis on internal R&D throughout its history has led to the creation of a company with the ability to adapt quickly to the changing needs of the customer and market while at the same time offering competitive prices and fast turnaround times.

APPLICATIONS

MITEQ's components and systems are supplied to a wide variety of military and commercial markets including:

- Satellite and ground-based communication systems
- Missile guidance
- Military electronic countermeasures, radar warning and surveillance systems

- Land, sea, and airborne radar
- Air traffic control radar
- Radioastronomy
- Research and development efforts

MANUFACTURING AND DESIGN CAPABILITIES

MITEQ's state-of-the-art facilities presently consist of five adjacent buildings totaling 217,000 square feet. In addition to housing fourteen separate engineering and manufacturing groups, MITEQ prides itself on its support groups including: drafting, which uses the latest commercial CADD and proprietary software programs; and an extensive machine shop, which includes top-of-the-line numerically-controlled Okuma, Mitsui Seiki and Matsuura vertical machining centers capable of machining to the tightest of tolerances, guaranteeing repeated accuracy and reliability. MITEQ has three Class 100,000 and two Class 10,000 cleanrooms in support of high reliability space and military applications.

To accomplish the engineering, manufacturing and testing of MITEQ's components and assemblies, MITEQ invests heavily in capital equipment. This state-of-the-art equipment includes a wide array of vector network analyzers and synthesized sources, phase noise test sets, custom noise figure measuring equipment, glass furnace equipment to control the process of glass sealing, thermal/humidity chambers, and PIND and shock and vibration stations for environmental screening, to name a few.

QUALITY ASSURANCE

MITEQ is recognized as a world class supplier with an outstanding reputation for product quality. MITEQ has undergone the extensive **ISO-9001:2000** certification process to help secure its future as a primary source for advanced microwave products.

SPACE HERITAGE

MITEQ's continued advancements in this state-of-the-art and unique capability have led to a wide acceptance by the microwave community as a forerunner in spaceborne technology. Our space-qualified components include mixers, amplifiers, synthesizers, and super-components. MITEQ's Space-Qualified Quality Assurance Plan establishes the actions necessary to provide confidence that the end item will meet the quality, reliability, and electrical performance required for space-qualified applications. Recent space platforms include:

- AMSU-B • SSMIS • GEOSAT • SEAWINDS • P-99 • P-02
- SEASAT • SPINSAT • TOPEX

CUSTOMER SERVICE

MITEQ continually evaluates its service procedures to ensure that a close relationship is maintained between the company and its customers. The goal in every case is to deliver products of exceptional quality, backed by responsive technical and administrative support. MITEQ remains committed to offering comprehensive technical support to its customers through a direct customer-to-MITEQ engineering link. This enables a quick response to the customer's needs, and ensures receipt of exactly what the customer requires: Delivery of cost-effective solutions for the most demanding applications.

AFS TECHNOLOGY OVERVIEW

CIRCUIT DESCRIPTIONS

MITEQ's AFS amplifiers utilize gallium arsenide transistors (GaAs FETs) and incorporate design techniques established at MITEQ along with others commonly used throughout the industry. The primary approach used by MITEQ's AFS/AFD Department is based upon what is commonly known as a single-ended design architecture. This approach uses a single transistor per stage with either series or parallel feedback designs to facilitate matching the amplifiers' impedance to 50 ohms.

Series feedback is also known as "lossless" feedback because there are no additional lossy circuits added to the input of the FET. This approach is the basis for the design that drives MITEQ's state-of-the-art noise figure performance. Although difficult to optimize, a lossless feedback design provides the lowest noise figures available in the industry today.

Before MITEQ established proficiency in using feedback to match the impedance of the transistor, other

approaches were utilized, including a balanced amplifier design. Most of MITEQ's AFD series amplifiers are based upon this approach, where each amplifier stage utilizes 90° hybrids at the input and output to feed two discrete transistors.

Utilizing 90° hybrids at the input and output of each stage, plus having two FETs per stage, offer the following advantages:

- Good VSWR characteristics due to the reflections adding in the termination of the 90° hybrid.
- Multiple stages are easily cascadable since interstage matching is not a problem due to the 90° hybrids.
- Easy power matching due to 90° hybrids; therefore, amplifiers can be optimized for noise figure.

- Improved output power performance due to multiple devices per stage.

In implementing this type of design, the designer must consider that the loss of the 90° hybrid will degrade the minimum achievable noise figure. In addition, this design is bandwidth limited due to the problems in realizing multioctave 90° hybrids. The broadest AFD amplifiers offered today at MITEQ are 2 to 18 GHz.

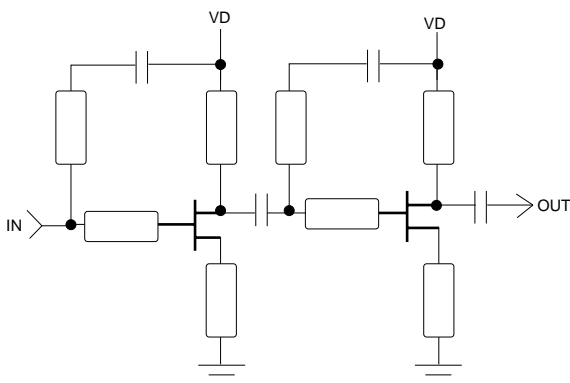

SINGLE-ENDED FEEDBACK DESIGN

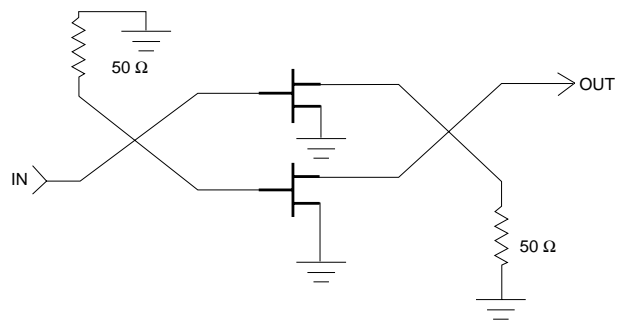

BALANCED AMPLIFIER DESIGN

AFS TECHNOLOGY OVERVIEW

Although MITEQ offers a wealth of catalog amplifier designs, the majority of the AFS Department's requirements are in supplying amplifiers to custom applications. To meet this demand, our engineers combine all available amplifier circuits in a variety of combinations to achieve desired performance not attainable through standard designs or catalog MMIC circuits.

CONSTRUCTION

MITEQ's AFS amplifiers are manufactured with our internal thin film hybrid manufacturing process. This type of microwave integrated circuit construction (MIC), was introduced to MITEQ during the early 1970s and has been the main manufacturing technique of our amplifiers ever since. Our expertise in this form of micro miniature integration has allowed MITEQ to achieve truly state-of-the-art performance, particularly in the areas of low noise figure and broad-band amplifier design.

All AFS and AFD amplifiers use a technique where the FETs and substrates are mounted directly to the

chassis. This "direct solder" technique was developed at MITEQ in the early 1980s and has allowed MITEQ to achieve a physically smaller mechanical interface between the input stage and the coaxial transition, making lower noise figures possible. In addition, the tighter interstage tolerances assist in achieving the broader bandwidths that both of these series require. Through the use of our extensive in-house machining capabilities, tight tolerances not available through outside machine shops have made this technique the main approach to amplifier design within MITEQ.

PACKAGING

MITEQ's AFS/AFD series amplifiers are available in various outlines. The AFS chassis is a two-part construction that

includes the amplifier housing mounted in a fixture to which the SMA connectors are attached. This chassis has proven extremely versatile in adapting to either coaxial or microstrip applications by offering a pin height above ground plane of only .070" when the mounting fixture is removed.

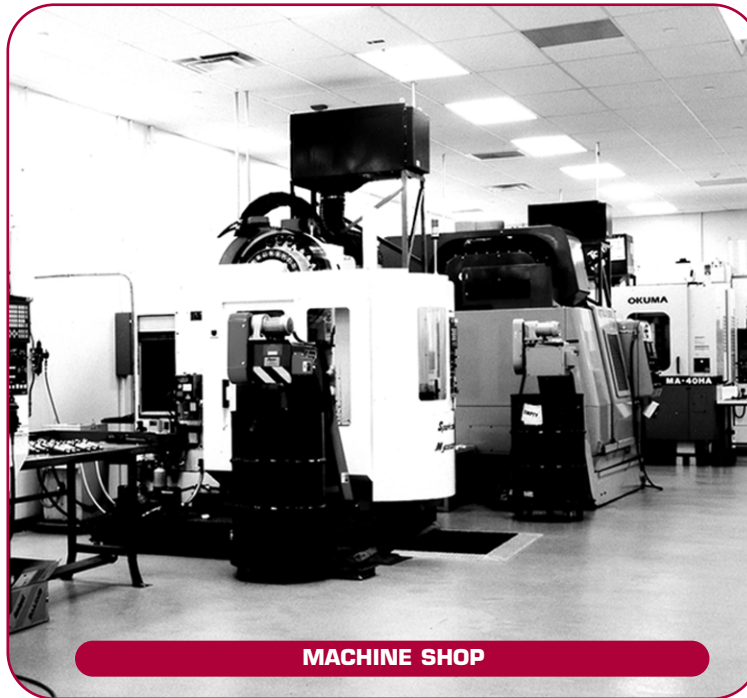

MACHINE SHOP

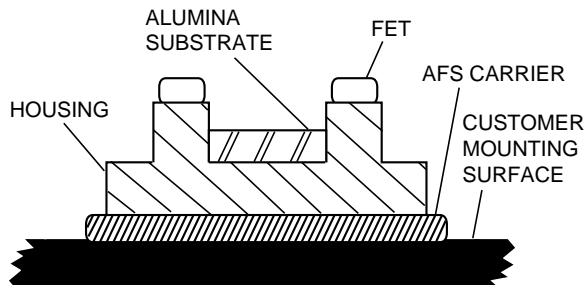

DIRECT SOLDER DESIGN

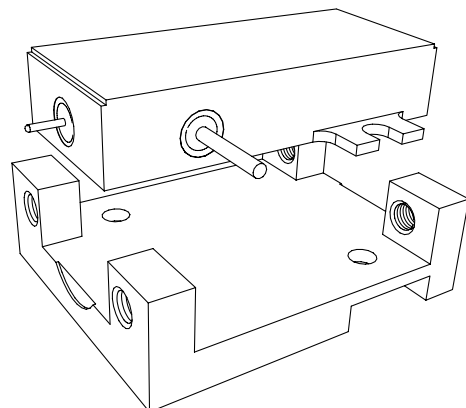

AFS AMPLIFIER WITH CARRIER ASSEMBLY

AFS TECHNOLOGY OVERVIEW

Due to its size, the AFS chassis can support only single-ended designs. When balanced designs are required, the AFD style outline is utilized. Along with these two coaxial packages, there are a variety of application-specific mechanical designs which are offered as standard catalog items, including:

- Surface mount
- Substrate
- Coaxial in-line
- Desktop



SPECIFICATION DEFINITIONS

GENERAL SPECIFICATIONS

Most models defined within this catalog are classified by several specifications, namely:

- Operating frequency range
- Output power at 1 dB compression
- Gain
- Gain flatness
- Noise figure
- Input and output VSWR
- DC supply voltage and current consumption

Most of the specifications for the MITEQ amplifiers listed in this catalog are based on operation at normal room ambient conditions of 23°C. For amplifier requirements at other temperatures and environments, please consult the factory or your local representative.

OPERATING FREQUENCY RANGE

The operating frequency range is the range of frequencies over which the amplifier will meet or exceed the specification parameters. The amplifier may perform beyond this frequency range, and in cases where the amplifier is specified over less than an octave, the actual frequency response may be significantly greater than the specified operating frequency range.

PLEASE NOTE: If an engineer is interested in limiting the response beyond the specified operating frequency range, this should be defined as a separate specification item. In this case, MITEQ can usually incorporate band limiting elements to meet the desired response.

GAIN

Gain is defined as the ratio of the power measured at the output of an amplifier to the power provided to the input port. It is usually expressed in decibels and is typically measured in a swept fashion across the operating frequency range. Unless specified, 100% test data supplied by MITEQ will include gain data

taken at several points within the band; however, in all cases, the amplifier gain has been measured in a swept fashion with performance verified over the entire frequency band.

GAIN FLATNESS

Gain flatness describes the variation in an amplifier's gain over the operating frequency range at any fixed temperature within the operating temperature range. As such, it does not include the variation of gain as a function of temperature (see Gain Variation vs. Temperature).

The gain flatness of an amplifier is measured by viewing the swept gain and determining the difference between the minimum gain and the maximum gain

recorded over the operating frequency range. Unless the amplifier is specified to operate over a defined temperature range, this measurement is performed at room ambient temperature (23°C). If a range of temperatures is specified, the measurement must also be verified at the temperature extremes.

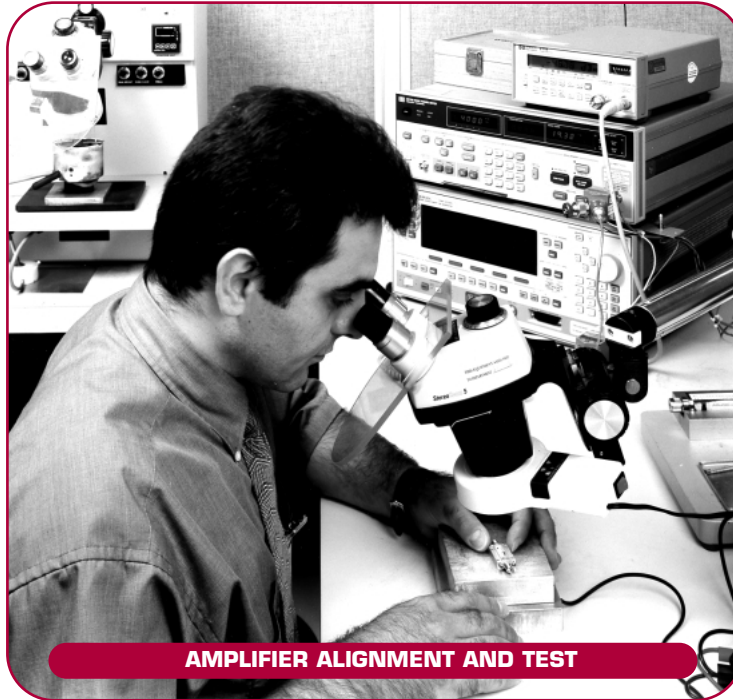

AMPLIFIER ALIGNMENT AND TEST

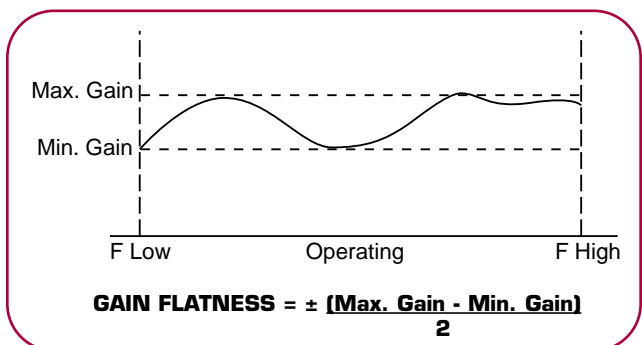

NOISE FIGURE

Noise figure is classically defined as:

$$\text{Noise figure} = \frac{S_i/N_i}{S_o/N_o} = \frac{\text{Signal-to-noise ratio at the amplifier input}}{\text{Signal-to-noise ratio at the amplifier output}}$$

SPECIFICATION DEFINITIONS

Since all amplifiers add thermal noise, the signal-to-noise ratio at the output will be degraded. Therefore, the noise figure will be a ratio greater than one, or when expressed in decibels, a positive number i.e. $NF_{dB} = 10 \text{ Log}_{10} (NF \text{ Ratio})$. The additive noise of an amplifier can also be expressed in a parameter referred to as noise temperature. In this approach, the noise temperature of the amplifier is equal to the temperature (in Kelvin) of a 50 ohm termination at the input of an ideal noiseless amplifier with the same gain and generating the same output noise power.

The relationship between noise figure and noise temperature is :

$$\text{Noise Figure} = 10 \text{ Log}_{10} \left\{ \frac{\text{Noise Temp. (K)} + 1}{290 \text{ K}} \right\}$$

Noise figure data is measured at discrete frequencies throughout the band. Test data is supplied at +23°C unless specified otherwise.

OUTPUT POWER AT 1 dB COMPRESSION

The 1 dB output compression point of an amplifier is simply defined as the output power level at which the gain drops 1 dB below the small signal.

All active components have a linear dynamic range. This is the range over which the output power varies linearly with respect to the input power. As the output power increases to near its maximum, the device will begin to

saturate. The point at which the saturation effects are 1 dB from linear is defined as the 1 dB compression point. Because of the nonlinear relation between the input and output power at this point, the following relationship holds:

$$P_{\text{out } 1 \text{ dB}} = P_{\text{IN } 1 \text{ dB}} + \text{Linear Gain} - 1 \text{ dB}$$

INPUT AND OUTPUT VSWR

Most RF and microwave systems are designed around a 50 ohm impedance system. An amplifier's impedance is designed to be as close as possible to 50 ohms; however, this is not always possible, especially when attempting to simultaneously achieve a good noise figure. The Voltage Standing Wave Ratio (VSWR) of an amplifier is a measure of an amplifier's actual impedance (Z) with respect to the desired impedance (Zo), in most cases 50 ohms.

The VSWR is derived from the reflection coefficient Γ , where Γ is a ratio of the normalized impedance:

$$\Gamma = \frac{Z - Z_0}{Z + Z_0}$$

and:

$$VSWR = 1 + \frac{|\Gamma|}{1 - |\Gamma|}$$

VSWR is "measured" with either a scalar or vector network analyzer. The reflection coefficients are determined by comparing the incident power and the reflected power at both ports of the device which in turn are converted and displayed as VSWR. The ratio of the reflected power to the incident power is also known as the return loss.

NOISE FIGURE CHART

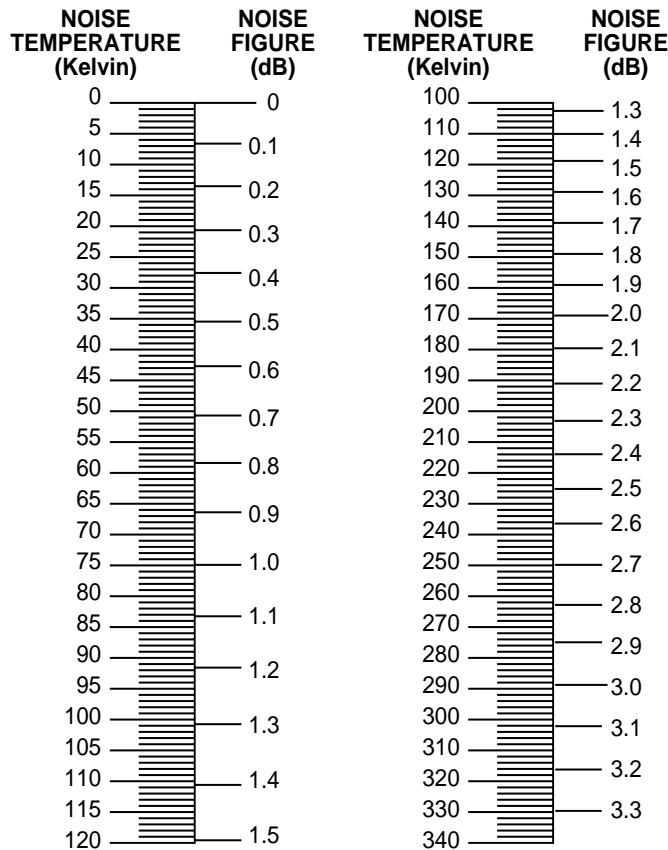

NOISE FIGURE VERSUS NOISE TEMPERATURE

SPECIFICATION DEFINITIONS

DC SUPPLY VOLTAGE AND CURRENT CONSUMPTION

Amplifiers, being active devices, require DC power supplies for their operation. MITEQ's amplifiers typically require 15 volts and include an internal voltage regulator. The use of a regulator allows for specification compliant operation even in the presence of power supply voltage variations, as long as minimum voltage supplied is greater than the specified drop-out voltage of the regulator. MITEQ also includes reverse voltage protection diodes on the DC line to prevent damage due to the application of a negative voltage.

ADDITIONAL SPECIFICATIONS

In addition to the electrical specifications for most of the models within this catalog, there are additional specifications useful to the engineer designing around stringent system requirements:

- Gain variation vs. temperature
- Overall gain window
- Intercept point
- Dynamic range
- Harmonic suppression
- Reverse isolation
- Phase and amplitude matching and tracking
- Phase linearity
- Recovery from saturation

GAIN VARIATION VS. TEMPERATURE

Gain variation versus temperature defines the maximum allowable variation of the linear gain due to temperature at any discrete frequency. As a result, this parameter does not account for drift over frequency.

Gain variation versus temperature is measured by performing swept gain measurements at the specified temperature extremes and comparing the deviations

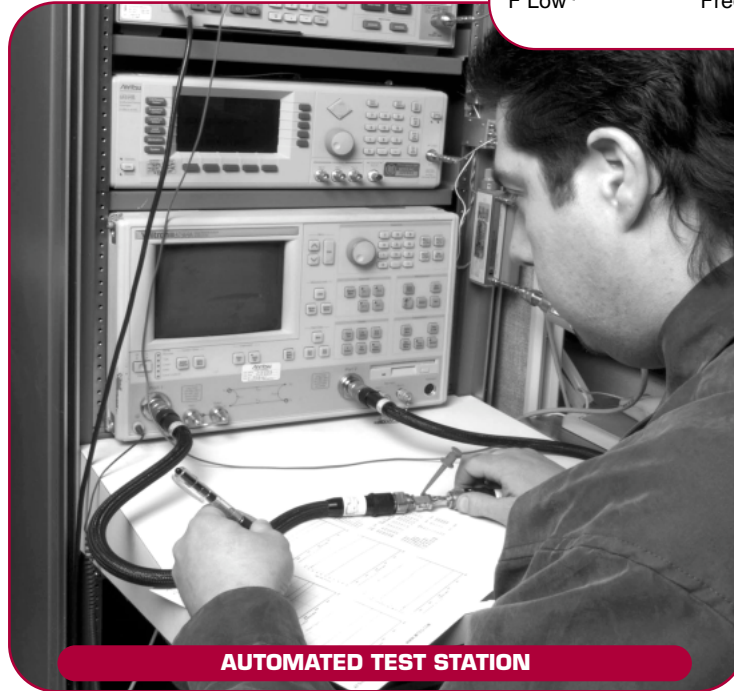
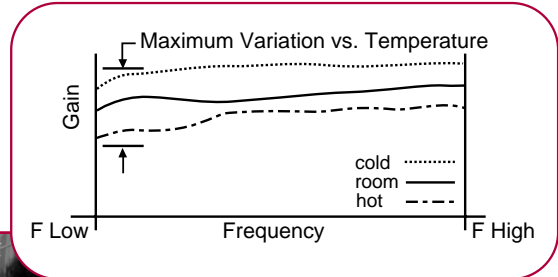

AUTOMATED TEST STATION

between the two sweeps at each frequency to determine the greatest change. When a \pm value is used, then the delta is taken at both temperature extremes with respect to room temperature (23°C). (For typical gain variation values vs. temperature see Thermal Considerations section.)

OVERALL GAIN WINDOW

An overall gain window specification defines the absolute minimum and maximum gain values over both temperature and frequency.

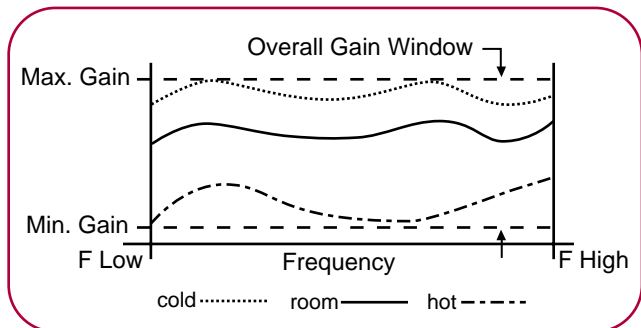

It is the most complete way to specify an amplifier; however, it also impacts the price due to the additional testing and alignment required by adding this constraining parameter.

INTERCEPT POINT

Solid state amplifiers use transistors, either bipolar or field effect, to provide gain. Although these transistors are generally used in a linear mode (except in the

SPECIFICATION DEFINITIONS

case of other than a Class A amplifier), they still exhibit nonlinear phenomenon, such as intermodulation effects and harmonic generation. These effects are evident in spurious products present at the output. In the case of the single-tone condition, the spurious signals are the harmonics of the fundamental input signal. In the case of the two-tone condition, the spurious signals are a product of mixing two input signals at the frequencies f_1 and the other at f_2 . The most

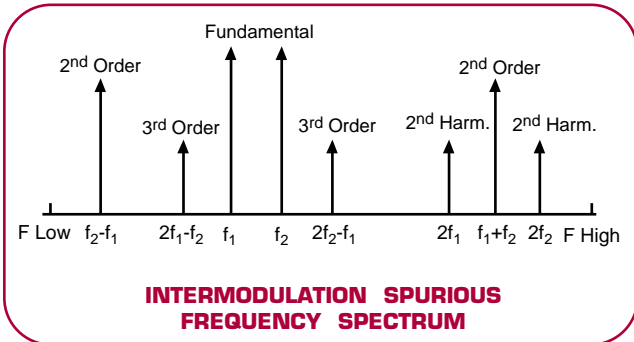

common are the second order and the third order two-tone spurs.

Second order two-tone spurs are the sum and difference product of the fundamental input frequencies, i.e.,

$$f_{SPUR} = f_1 \pm f_2$$

These spurious signals are only of concern when the band is greater than one octave. If the frequency range is less than one octave, the two-tone second order spurs will be out of band.

These spurious signals are characterized with respect to the input signal by means of a theoretical tool called an intercept point. These points are defined as the point where the linear curve of input vs. output power of the fundamental would intersect with the linear curve of the spurious signal if saturation effects would not limit the output levels of these signals. Since it is known that the second order spurious products have a slope of 2:1 with respect to the fundamental input power, the value of the spurs can be estimated if the input signal power (P_{IN}) and the output second order intercept point (OIP_2) are known. The relationship is as follows:

$$\text{Two-tone second order spurious suppression} = OIP_2 - (P_{IN} + G)$$

$$\text{Two-tone second order spurious level} = 2(P_{IN} + G) - OIP_2$$

Third order spurious products result from combinations of the fundamental signal and the second harmonics.

$$f_{SPUR} = |2f_1 \pm f_2| \pm |f_1 \pm 2f_2|$$

The slope of third order spurious signal is 3:1 with respect to the fundamental input power, and again the value of the spurs can be estimated if the input signal power (P_{IN}) and the output third order intercept point (OIP_3) are known. The relationship is as follows:

$$\text{Two-tone third order spurious suppression} = 2 \{OIP_3 - (P_{IN} + G)\}$$

$$\text{Two-tone third order spurious level} = 3(P_{IN} + G) - 2 OIP_3$$

DYNAMIC RANGE

Dynamic range can be defined in several ways. The two classical methods are to define the linear dynamic range and the spurious free dynamic range.

The linear dynamic range defines the difference between the Minimum Detectable Signal (MDS), referred to the input of the amplifier or receiver and the maximum signal level at which the amplifier remains linear. This is typically defined by the input 1 dB compression point ($P_{IN} 1 \text{ dB}$). The minimum detectable signal is defined by system constraints, such as noise figure, bandwidth and predetection signal-to-noise ratio.

Spurious free dynamic range is defined as the difference between the minimum detectable signal and the point at which the intermodulation signals generated from two equal tones would either equal this MDS or some other acceptable level. The dynamic range can

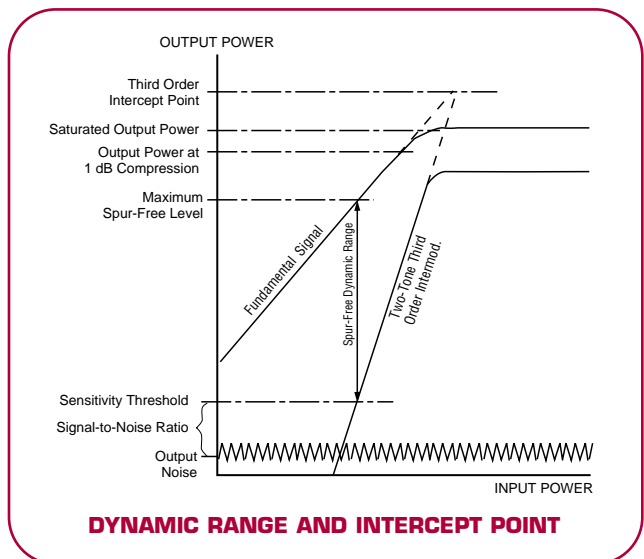

SPECIFICATION DEFINITIONS

be easily derived by the following relationship:

$$\text{Two-tone spurious free dynamic range} = (2/3) (IP^3_{\text{INPUT}} - \text{MDS})$$

$$\text{MDS (dBm)} = -114 + 10 \log_{10} (\text{BW in MHz}) + \text{N.F.} + \text{SNR}$$

REVERSE ISOLATION

Reverse isolation simply defines the isolation between the input and output of an amplifier. It is tested by injecting a signal into the output port and measuring its level at the input. Typically, reverse isolation is twice the gain.

PHASE LINEARITY

The phase of a signal versus frequency will be distorted due to the nonlinear phase elements within the amplifier. This distortion is called phase linearity and is measured by means of a vector network analyzer across the operating frequency range.

PHASE MATCHING

Phase matching, in the strict sense, is defined as the difference in insertion phase between any two or more units. This parameter is usually defined across the operating frequency band, however, in some cases it is defined over frequency segments (ΔF) within the overall operating band.

In the case of the definition over the entire band, the insertion phase is measured by means of a vector network analyzer, stepped across the band. The values at each frequency for two amplifiers are subtracted to provide a delta plot across frequency. Since each system has its own peculiarities, there are a wide variety of variations of this definition. Therefore, if your system requirements are such that this definition does not accurately meet your needs, or if this level of definition exceeds your real need and results in higher cost, you should contact MITEQ's engineering staff to discuss the most cost effective options.

PHASE TRACKING

Phase tracking is very similar to phase matching. However, an arbitrary fixed offset exists between the amplifiers that can usually be compensated by the system software. The offset, sometimes referred to as the DC component (because all that remains is the phase versus frequency ripple and slope), is calculated at each temperature based upon an average over the band. As with phase matching, there are many variations on this theme that also should be discussed with MITEQ's engineering before committing to a final specification.

AMPLITUDE MATCHING

Same as phase matching, except substitute gain for phase.

AMPLITUDE TRACKING

Same as phase tracking, except substitute gain for phase.

AM TO PM CONVERSION

This specification parameter defines the change in phase at any fixed frequency within the operating band relative to the input signal power. It is usually defined in terms of degrees per dB ($^{\circ}/\text{dB}$) over a specified input dynamic range. Most GaAs FET amplifiers exhibit well-behaved AM/PM conversion (less than $1^{\circ}/\text{dB}$) up to a few dB below the 1 dB compression point. Beyond the 1 dB compression point, the variation can be quite large, depending on the devices and biasing conditions used.

PULSE CONDITIONS

A variety of pulse conditions can be specified for an amplifier, including amplitude or phase overshoot and ringing, amplitude or phase settling time, recovery time, etc. As with the matching and tracking specifications, they are typically system dependent and rarely fall into a standard definition. Therefore, it is best to contact MITEQ's engineering staff when attempting to define the operation of an amplifier in the presence of pulsed signals.

MAXIMUM INPUT POWER

Most low noise figure amplifiers will withstand an input level of 13 dBm CW. In the event that you require a higher input level, an input limiter can be added to the front end of the amplifier in order to protect it. The problem with the addition of the limiter is that its insertion loss is directly additive when calculating the overall noise figure.

THERMAL CONSIDERATIONS

The following information can be used as a guide relative to the changes in performance of an amplifier as a function of temperature.

GAIN

The gain of a typical amplifier, that is not temperature compensated, tends to decrease as the operating temperature of the device increases. Since most low-noise amplifiers have their specifications defined at 23°C, the difference in the gain caused by temperature is approximately 0.01 dB/°C/stage for driver stages and 0.015 dB/°C/stage for power stages. By temperature compensating the amplifiers, improvements of 1/4 to 1/2 of the uncompensated gain change can be realized depending on the frequency bandwidth, gain, power, and temperature extremes.

1 dB COMPRESSION POINT

The 1 dB compression point of a low-noise amplifier varies inversely proportional to the operating temperature. As the temperature increases over room temperature (23°C), the 1 dB compression point will typically decrease up to 0.01 dB/°C.

NOISE FIGURE

The noise figure of a typical amplifier will increase as the operating temperature of the device increases over room temperature (23°C). This rise in noise figure is typically 0.01 dB/°C. Thus, if the noise figure of an amplifier is defined by the manufacturer as 0.9 dB, and the unit has to operate at 85°C, the expected noise figure will be approximately:

$$[85^{\circ} - 23^{\circ}\text{C}] [0.01 \text{ dB}/^{\circ}\text{C}] + 0.9 \text{ dB} = 1.52 \text{ dB}$$

Similarly, for cold temperatures, the noise figure decreases at the same rate.

HEATSINKING

All of MITEQ's amplifiers utilize active components that generate heat when bias is applied. As such, proper mounting must be achieved to maintain the junction temperatures of the devices and ensure specification compliant operation. This is done via conduction cooling of the amplifier case to a base plate or mounting surface. It is recommended that the mounting surface is smooth and clear of any foreign substances, so that there is a clear thermal path between the base plate of the amplifier and that of the mounting surface. We also recommend that thermal grease be used wherever possible to enhance the conductivity of the thermal path.

Since the amplifiers are sealed, there is no way to

remove the heat other than by conduction, even if the ambient temperature is significantly below that of the base plate. For higher power models, heatsinks are required. Please consult the factory for details.

In order to increase the efficiency and reduce the thermal stress on the components in our amplifiers, MITEQ has done extensive research on the thermal effects of the heat generating devices in our amplifier designs. Most of our designs use either aluminum, copper/tungsten, or Kovar for the chassis, and aluminum for the mounting fixture, as shown below.

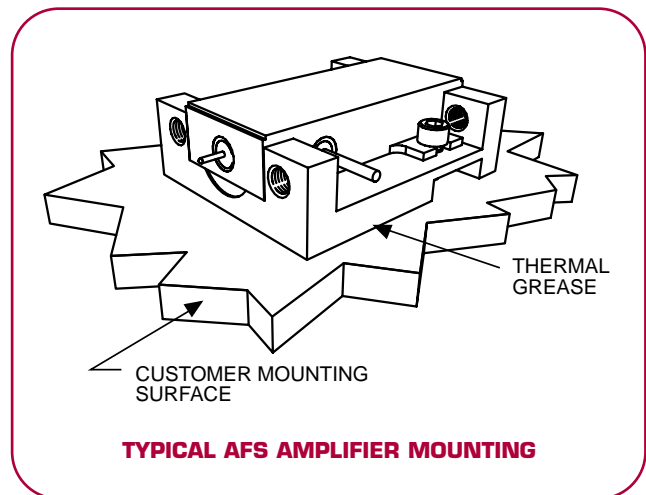

TYPICAL MEDIUM POWER AMPLIFIER CONFIGURATION

It is important for the user to understand that in addition to the thermal resistance of the chassis metal, every interface, starting with the mounting of the FET into the amplifier package, results in a thermal gradient. As such, one should try to minimize these various interfaces by directly soldering the unit wherever possible.

In order to minimize the amount of heat dissipated, MITEQ either eutectically bonds or epoxies the FETs directly to the housing. Since most of the FETs are less than 20 x 20 x 5 mils and the mounting posts are large, there is a good thermal path between the FET and the chassis. Typical power dissipation for the FETs in a two-stage low-noise amplifier is in the order of 100 mW. For a medium power FET with a gate-to-gate spacing of 56 μm and a gate finger width of 200 μm (two fingers/FET), the maximum channel temperature can be calculated to be 135°C, for a base plate temperature of 85°C. The equation is as follows:

$$T_J = T_{\text{case}} + (V_{DS})(I_{DS})(R_{\theta JC})$$

To further guarantee a good thermal path, the base of

THERMAL CONSIDERATIONS (CONT.)

TYPICAL GaAs FET SPECIFICATIONS

CHARACTERISTICS	MEDIUM POWER	HIGHER POWER
Dimension (inches)	0.022 x 0.014 x 0.004	0.019 x 0.014 x 0.004
Gate finger width	200 μm	100 μm
Gate-to-gate spacing	56 μm	25 μm
# FETs	2	2
# Gate fingers/FET	2	5
Power dissipation (W)	0.16	0.16
Total periphery	0.8 mm	1.0 mm
Q ccb (C/W)	80	86
ΔT (C)	12.8	13.8

TYPICAL THERMAL CONDUCTIVE EPOXIES

TYPE	THERMAL CONDUCTIVITY BTU/in./ft. 2hr. °F	MAXIMUM OPERATING TEMP. CONTINUOUS °C
H20E	11.5	125
H31D	11.5	150
H35-175MP	11	175

both the amplifier and mounting fixture should be machined to very fine tolerance (i.e., 0.001"/inch).

This equates to a contact conductance of approximately 550 BTU/hr-ft²-F.

QUALITY ASSURANCE

QUALITY ASSURANCE

MITEQ believes that quality must be built into all of the products that we manufacture. As such, we take extreme care in maintaining a complete and detailed product assurance program. Our product quality is structured to and operates within the precepts of ISO 9001 and to MIL-I-45208. This, in turn, allows us to meet the rigorous requirements generated by our customers in the aerospace, military, and commercial sectors. Internal procedures are used to relate all functions affecting quality, from initial design through final acceptance. These procedures detail the responsibilities and functions necessary to maintain effective controls and to provide a means for evaluating quality disciplines during all phases of a job's performance.

Beginning with the audit of the customer's contract, our Quality Assurance Department will review and evaluate the contract and all of the specifications applicable to the job. Quality requirements and characteristics are highlighted and adequate plans are implemented to ensure the incorporation of all aspects pertaining to overall product quality. Quality assurance activities will be coordinated with engineering, manufacturing, and procurement during all phases of

an order to ensure the transmittal of complete quality information to all manufacturing centers and inspection stations in a manner consistent with schedule requirements.

MITEQ, through our Quality Assurance and Purchasing Departments, is responsible for the quality of all purchased items. Procurement sources will be selected and approved, based upon the supplier's quality history records, facility and quality system surveys, or coordinated industry records. Approved sources will be required to maintain a quality program that is commensurate with the requirements of the items being purchased and in compliance with the contract.

Copies of MITEQ's Quality Manual and Workmanship Standard, that define the methods used for both quality and process control, are available upon request.

TEST EQUIPMENT

MITEQ maintains a complete inventory of the latest state-of-the-art mechanical, electrical, and manufacturing test equipment. Equipment calibration and maintenance is performed and is traceable to the requirements of MIL-STD-45662A.

MEAN TIME BETWEEN FAILURE (MTBF)

For the past 30 years, MITEQ has supplied thousands of different models of microwave hybrid amplifiers to the industry.

Reliability calculations have been performed in accordance with MIL-HDBK-217F for ground benign equipment at 23°C. From these calculations MITEQ has concluded that these amplifiers are extremely reliable.

CASE I

A low-noise amplifier built to commercial standards using commercial parts.

CASE II

The same amplifier built in a kovar chassis, hermetically sealed, using commercial parts, but screened in accordance with MIL-PRF-38534 Class H.

CASE III

The same amplifier built in a kovar chassis, hermetically sealed but, consisting of specially purchased high-reliability components and screened in accordance with MIL-PRF-38534 Class K.

Our low-noise amplifiers are estimated to have a minimum MTBF per the following table:

MTBF (HOURS)				
CASE	ONE-STAGE AMPLIFIER	TWO-STAGE AMPLIFIER	THREE-STAGE AMPLIFIER	FOUR-STAGE AMPLIFIER
CASE I	300,000	200,000	120,000	115,000
CASE II	3,000,000	2,000,000	1,200,000	1,100,000
CASE III	12,000,000	8,200,000	4,900,000	4,400,000

The MTBF of low-noise amplifiers with more than four gain stages can be estimated by using the equations in the following table:

MTBF (HOURS)	
CASE	EQUATION
CASE I	$MTBF = 100,000 \text{ HRS.} \times 3/N$
CASE II	$MTBF = 1,000,000 \text{ HRS.} \times 3/N$
CASE III	$MTBF = 4,000,000 \text{ HRS.} \times 3/N$

Where N is the number of stages in the amplifier.

The above analysis is only relevant for low-noise low-power amplifiers (amplifiers where the 1 dB compression point is 10 dBm or less). High-power amplifiers require individual calculations and usually result in significantly lower calculations for the MTBF.

AFS/AFD MANUFACTURING FLOW DIAGRAMS

The following diagrams depict the process flow for both our commercial and high-reliability amplifiers:

COMMERCIAL GRADE AMPLIFIERS

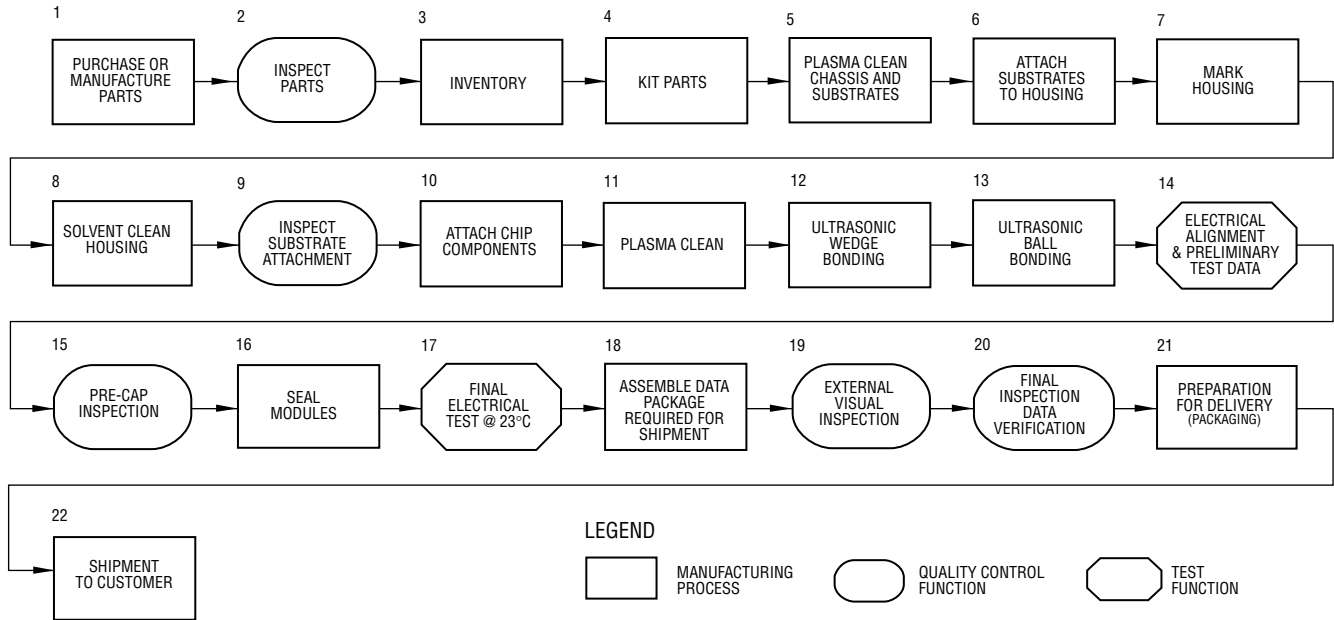

HIGH RELIABILITY HERMETICALLY SEALED AMPLIFIERS

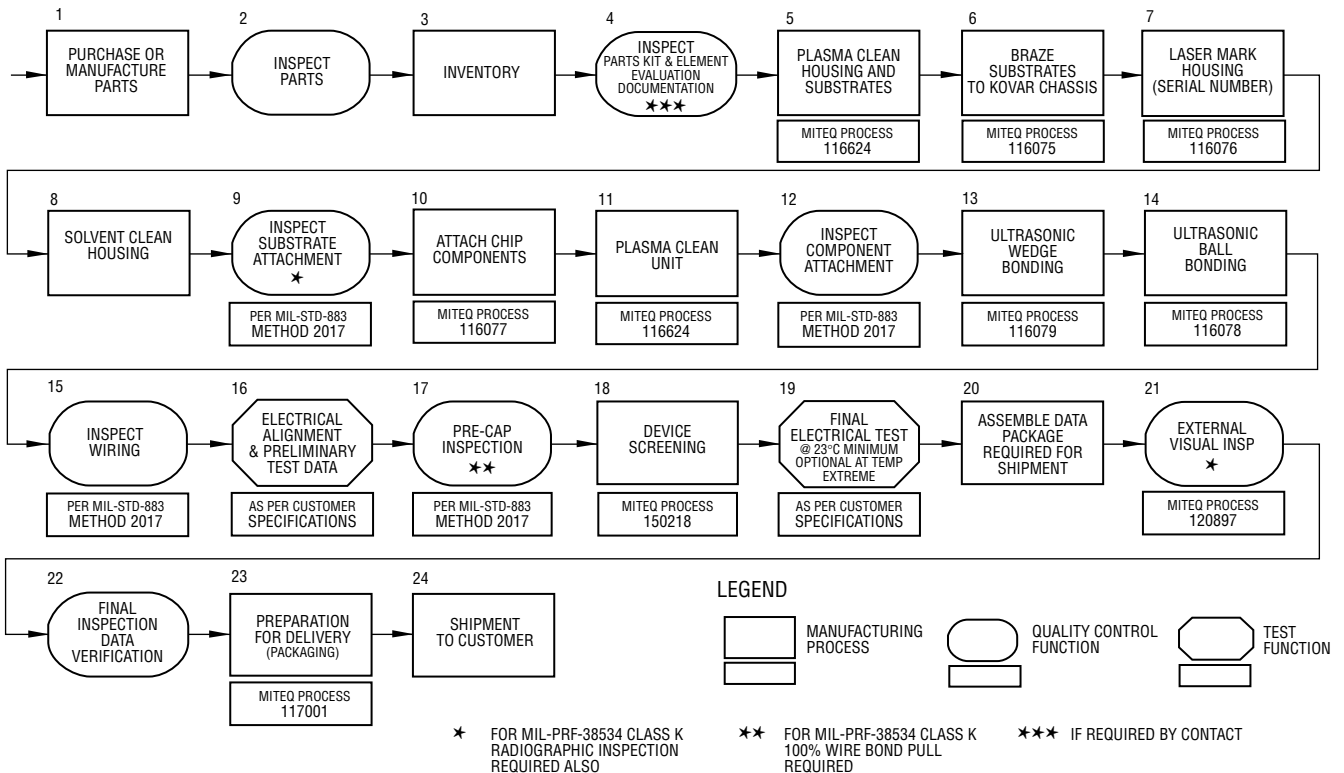

DEVICE 883 SCREENING

MITEQ maintains an assortment of its own environmental testing equipment to further ensure product quality and facilitate the testing of our products. Our environmental lab is capable of testing the following:

- Mechanical shock
- Vibration
- Burn-in
- Temperature cycling
- Thermal shock
- Gross leak
- Fine leak

The optional device screening shown here is as per MIL-PRF-38534E Table C-1X Class H and MITEQ Traveler Number 150218.

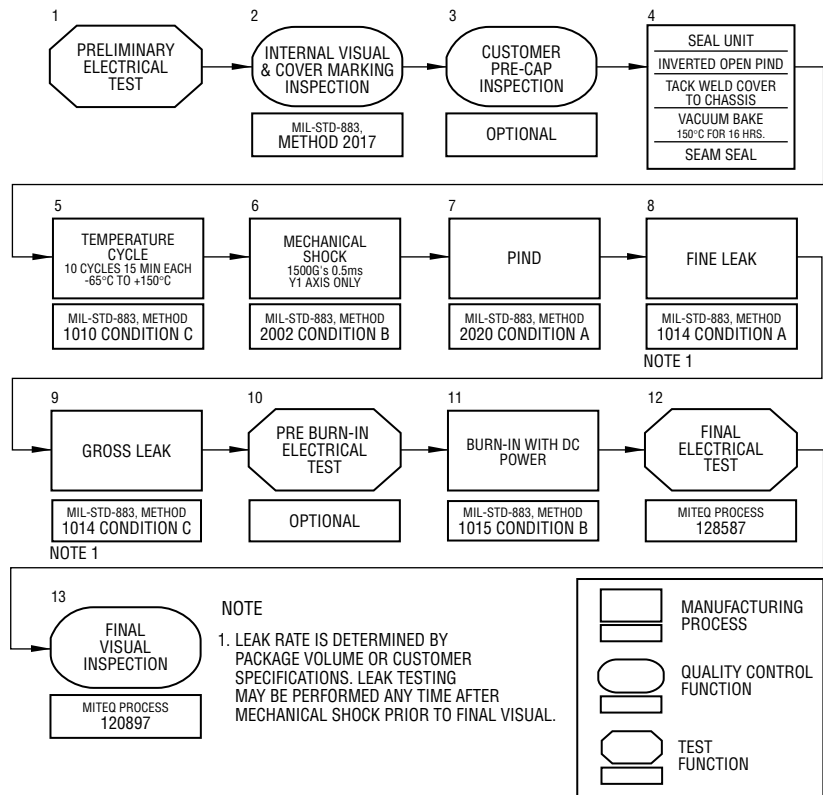

GENERAL SPECIFICATIONS

MITEQ's standard amplifiers have been designed to meet the following environmental conditions:

Operating temperature..... -54 to +85°C
 Storage temperature..... -65 to +125°C
 Humidity 95% relative humidity, noncondensing

Vibration..... 7 g's rms, 50-5000 CPS, per MIL-STD-810B, Method 514, Procedure 5

Data curves are at 25°C..... There will be some variation in the typical data shown as a function of temperature

SPACE-QUALIFIED AMPLIFIERS

MITEQ is a leading supplier of RF and microwave components, equipment, and systems for both commercial and defense applications, including; satellite, avionics, reconnaissance, surveillance, radar, and electronic countermeasure systems. Our continued advancements in the state-of-the-art and unique capability have led to wide acceptance of our company as a forerunner in the field of low-noise amplifier technology for space applications. We are confident that based on our experience we can offer you the following:

- Mature technology with heritage on space flight platforms.
- An organization dedicated to developing and manufacturing the very best low-noise amplifiers for space use.

- A staff of amplifier experts with state-of-the-art experience in both space and military type amplifiers.
- Cost competitive products.
- Low risk (both technical and schedule), through an extensive inventory of standard designs.
- Very high reliability.

MITEQ's Space-Qualified Quality Assurance Plan establishes the actions and controls necessary to provide confidence that the end-item will meet the quality, reliability, and electrical performance required for space qualified applications. This plan includes the use of parts, materials, process controls, product screening, traceability, configuration control, and destructive physical analysis. Please contact MITEQ for a copy of our Space-Qualified Quality Assurance Plan.

CONFORMANCE TO CUSTOMER QUALITY REQUIREMENTS

MITEQ's involvement in various high-reliability space programs represents a spectrum of programmatic and quality requirements ranging from **MIL-STD-883 Class B** for cost sensitive programs, to requirements based on **Class S** and **MIL-PRF-38534 Class H** and **K**.

All open-die, thin-film products are manufactured and tested within MITEQ's clean rooms (FED-STD-209, Class 100,000 and Class 10,000) according to program requirements.

In addition to compliance to stringent manufacturing controls, MITEQ possesses the capabilities to support the **program management** and extensive **documentation requirements** of your space contracts including:

- Configuration Control
- Design Reviews
- Traceability
- Design Analysis
- FMECA
- MTBF
- WCA
- Thermal Analysis
- Parts Derating
- Parts, Processes Materials
- Dynamic Stress
- Process Documentation
- EMI/EMC

All analysis and support provided is based upon individual custom requirements as set forth in the customer Statement of Work and/or Specifications. MITEQ has established controls, procedures and a philosophy with the customer in mind. **Conformance to customer requirements** has been paramount in all the programs we have supported throughout our history. It is this philosophy that had secured our successes in the past, and will guarantee our success in the future.

SPACE HERITAGE

MITEQ has supplied hardware for space-flight missions for over twenty years. Our emphasis is predominantly in technically challenging requirements, particularly in the area of:

- Low-noise amplifiers
- High-performance microwave mixers
- Frequency synthesizers
- Custom designed assemblies

For many years MITEQ's primary space products have been low-noise amplifiers. However, MITEQ has been able to provide a wide spectrum of designs and custom assemblies by utilizing mature technology delivered on other high-reliability programs. With our extensive space experience, we have been able to use qualification data from our existing designs while delivering custom-engineered units, thereby offering reduced cost and shorter delivery times to our customers.

Below is a list of previous and existing space programs which MITEQ has supported:

MITEQ CUSTOMER	END USER	PROGRAM	YEAR
General Dynamics	Lockheed Martin	P-02	2003
Jet Propulsion Lab	NASA	EOS-MLS	2001
Assurance Technology Corp.	U.S. Navy	WINDSAT	2001
Motorola	-	P-99	2000
Aerojet	NASA	EOS-MLS	2000
Jet Propulsion Lab	NASA	MIRO	1999
Sandia National Lab	-	-	1999
ITT	-	-	1999
Sandia National Lab	-	-	1998
Matra Marconi Space	-	-	1998
Aerojet	NASA	SSMIS	1998
Sandia National Lab	-	-	1997
Johns Hopkins Applied Physics Lab	-	-	1997
Johns Hopkins Applied Physics Lab	U.S. Navy	ETB	1997
Matra Marconi Space	Eumetsat	MHS	1997
Motorola Government Systems	Lockheed Martin	P-94/P-97	1997
ITT	Lockheed Martin	-	1996/1997
Northrop-Grumman	-	-	1996
E-Systems	JPL	SEAWINDS	1996
Matra Marconi Space	ESA	MWR	1995
E-Systems	-	GEOSAT	1994
Aerojet	NASA	SSMIS	1993
Millitech	U.S. Air Force	SSMIS	1993
Lockheed	U.S. Air Force	STS-54	1993
Aerojet	NASA	AMSU-B	1992
Johns Hopkins Applied Physics Lab	U.S. Navy	TOPEX	1989
Johns Hopkins Applied Physics Lab	U.S. Navy	SPINSAT	1989
University of Bonn	-	-	1987
Johns Hopkins Applied Physics Lab	U.S. Navy	SEASAT	1986
Jet Propulsion Lab	NASA	-	1982
Johns Hopkins Applied Physics Lab	U.S. Navy	-	1982

HIGH-RELIABILITY PROGRAM CHECKLIST

Process Control Requirements

- Process control drawings
- Assembly travelers
- Test plans
- Test procedures

Parts Procurement Control

- Source control drawings for die and packaged parts only, or including substrates, passive parts, housings, etc. Should also include definition of element evaluation profile (100% and lot basis)
- Traceability logs
- Parts storage requirements
- Age limitations
- Customer parts approval

Reports

- Status reports (_____ interval)
- Customer interface meetings (_____ interval)
- Design reviews (_____ number)

Configuration Control

Reports and Analysis

- Thermal analysis
- Mean time between failure (MTBF)
- Failure analysis
- EMI analysis/test
- Failure mode effects analysis (FMECA)
- Worst case analysis (electrical performance)
- Stability analysis
- Parts derating
- Radiation susceptibility analysis/test

Customer Source Inspections

- Production documentation review
- Precap visual
- Final source inspection (testing and documentation review)

Component Screening

- MITEQ 883 Screening
- MIL-STD-883, Class _____
- MIL-PRF-38534, Class _____
- Customer defined

100% Unit Screening

- MITEQ 883 Screening
- MIL-STD-883, Class _____
- MIL-PRF-38534, Class _____
- Customer defined

Unit Quality Control Inspection (QCI) Testing

- MIL-STD-883 Group B testing
- Additional testing
- Customer defined

Qualification Testing

- MIL-STD-883 Group C and D testing
- Additional testing
- Customer defined

Process Qualification

- Process verification testing, (e.g., extended life tests, extended temperature cycles, destructive physical analysis, etc.)

Lot Requirements

- Manufactured timing constraints (homogeneous lot restrictions)
- Build vs. pass percentage for lot acceptance

AMPLIFIER MODELS

The amplifier models presented in the following sections represent a very small portion of our product line. Due to the quantity of models that are available from MITEQ, we have selectively chosen the models that are most often asked for by the majority of our customers. If there is a model that you do not see in the list that you have either purchased in the past or that is somewhat different from any of the items listed herein, please contact the factory so that we may serve your particular needs.

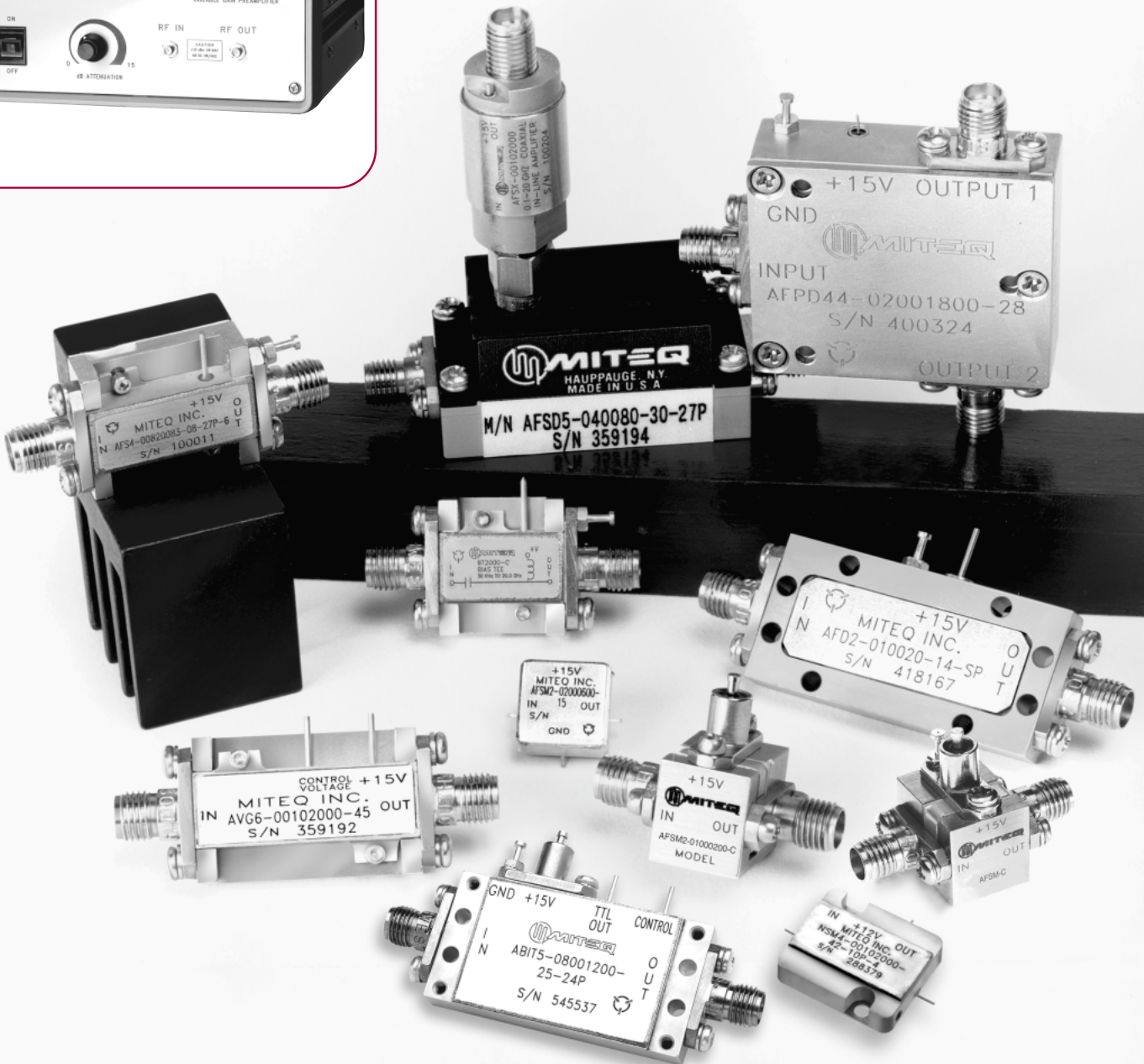

ULTRA-WIDEBAND AFS AMPLIFIERS

MODEL NUMBER	FREQUENCY RANGE (GHz)	GAIN (dB, Min.)	GAIN FLATNESS (±dB, Max.)	NOISE FIGURE (dB, Max.)	VSWR IN/OUT (Max.)	OUTPUT POWER @ 1 dB COMP. (dBm, Min.)	NOM. DC POWER (15 V, mA)	OUTLINE DRAWING
ULTRA-WIDEBAND								
AFS1-00100100-11-10P-4	0.1-1	14	1	1.1	2.5:1	10	50	4
AFS2-00100100-10-10P-2	0.1-1	25	1	1	2:1	10	100	2
AFS3-00100100-09-10P-4	0.1-1	38	1	0.9	2:1	10	125	4
AFS4-00100100-09-10P-4	0.1-1	45	1	0.9	2:1	10	175	4
AFS1-00040200-12-10P-4	0.04-2	15	1.5	1.2	2:1	10	50	4
AFS1-00100200-11-12P-4	0.1-2	14	1.5	1.1	2:1	12	75	4
AFS2-00100200-10-12P-2	0.1-2	25	1	1	2:1	12	100	2
AFS3-00100200-10-15P-4	0.1-2	38	1	1	2:1	15	150	4
AFS4-00100200-10-15P-4	0.1-2	46	1.5	1	2:1	15	175	4
AFS1-00100300-14-8P-4	0.1-3	10	1.5	1.4	2:1	8	75	4
AFS2-00100300-12-10P-2	0.1-3	20	1.25	1.2	2:1	10	100	2
AFS3-00100300-12-10P-4	0.1-3	32	1	1.2	2:1	10	125	4
AFS4-00100300-12-10P-4	0.1-3	40	1.5	1.2	2:1	10	150	4
AFS2-00100400-15-10P-4	0.1-4	16	1.25	1.5	2:1	10	80	4
AFS3-00100400-13-10P-4	0.1-4	28	1	1.3	2:1	10	125	4
AFS4-00100400-13-S-4	0.1-4	36	1	1.3	2:1	10	150	4
AFS2-00100600-15-10P-2	0.1-6	16	1.25	1.5	2:1	10	100	2
AFS3-00100600-13-10P-4	0.1-6	28	1.25	1.3	2:1	10	125	4
AFS4-00100600-13-S-4	0.1-6	36	1.5	1.3	2:1	10	150	4
AFS5-00100600-13-S-5	0.1-6	42	1.5	1.3	2:1	10	175	5
AFS2-00100800-15-S-2	0.1-8	16	1.5	1.5	2:1	10	80	2
AFS3-00100800-14-10P-4	0.1-8	28	1.5	1.4	2:1	10	125	4
AFS4-00100800-14-10P-4	0.1-8	36	1.5	1.4	2:1	10	150	4
AFS5-00100800-14-10P-5	0.1-8	42	1.5	1.4	2:1	10	175	5
AFS4-00101000-20-10P-4	0.1-10	28	1.5	2	2:1	10	150	4
AFS5-00101000-20-10P-5	0.1-10	34	1.5	2	2:1	10	175	5
AFS42-00101000-20-10P-42	0.1-10	42	1.75	2	2:1	10	220	42
AFS2-00101200-25-8P-2	0.1-12	14	1.5	2.5	2:1	8	80	2
AFS3-00101200-22-10P-4	0.1-12	25	1.5	2.2	2:1	10	100	4
AFS4-00101200-22-10P-4	0.1-12	30	1.5	2.2	2:1	10	150	4
AFS5-00101200-22-S-5	0.1-12	32	1.75	2.2	2:1	10	175	5
AFS42-00101200-22-10P-42	0.1-12	38	2	2.2	2:1	10	220	42
AFS2-00101400-30-5P-2	0.1-14	14	1.5	3	2.5:1	5	100	2
AFS3-00101400-23-8P-4	0.1-14	19	1.75	2.3	2.5:1	8	150	4
AFS4-00101400-23-10P-4	0.1-14	24	2	2.3	2.5:1	10	200	4
AFS5-00101400-23-10P-6	0.1-14	28	2.25	2.3	2.5:1	10	225	6
AFS6-00101400-23-10P-6	0.1-14	32	2.5	2.3	2.5:1	10	250	6
AFS2-00101600-30-8P-2	0.1-16	12	1.5	3	2.5:1	8	125	2
AFS3-00101600-23-8P-4	0.1-16	18	1.75	2.3	2.5:1	8	150	4
AFS4-00101600-23-10P-4	0.1-16	24	2	2.3	2.5:1	10	175	4
AFS5-00101600-23-10P-6	0.1-16	30	2.25	2.3	2.5:1	10	200	6
AFS6-00101600-23-10P-6	0.1-16	36	2.5	2.3	2.5:1	10	250	6
AFS2-00101800-30-8P-2	0.1-18	12	2	3	2.5:1	8	125	2
AFS3-00101800-25-S-4	0.1-18	22	2	2.5	2.5:1	8	150	4
AFS4-00101800-25-S-4	0.1-18	25	2	2.5	2.5:1	10	175	4
AFS42-00101800-25-S-42	0.1-18	35	2.5	2.5	2.5:1	10	225	42
AFS2-00102000-40-5P-2	0.1-20	10	2	4	2.5:1	5	75	2
AFS3-00102000-35-8P-4	0.1-20	15	2.25	3.5	2.5:1	8	100	4
AFS4-00102000-30-10P-4	0.1-20	20	2.5	3	2.5:1	10	125	4
AFS5-00102000-30-10P-6	0.1-20	24	2.5	3	2.5:1	10	150	6
AFS6-00102000-30-10P-6	0.1-20	28	2.5	3	2.5:1	10	175	6
AFS44-00102000-30-10P-44	0.1-20	36	3	3	2.5:1	10	300	44

NOTE: Noise figure increases below 500 MHz in bands greater than 0.1-10 GHz.

ULTRA-WIDE/MULTIOCTAVE BAND LOW-NOISE AFS AMPLIFIERS

MODEL NUMBER	FREQUENCY RANGE (GHz)	GAIN (dB, Min.)	GAIN FLATNESS (±dB, Max.)	NOISE FIGURE (dB, Max.)	VSWR IN/OUT (Max.)	OUTPUT POWER @ 1 dB COMP. (dBm, Min.)	NOM. DC POWER (15 V, mA)	OUTLINE DRAWING
ULTRA-WIDEBAND (CONT.)								
AFS3-00102200-40-8P-4	0.1–22	18	2.5	4	2.5:1	8	150	4
AFS4-00102200-40-10P-4	0.1–22	22	2.5	4	2.5:1	10	135	4
AFS42-00102200-40-10P-42	0.1–22	30	2.75	4	2.5:1	10	200	42
AFS44-00102200-40-10P-44	0.1–22	34	3	4	2.5:1	10	270	44
AFS2-00102650-55-8P-4	0.1–26.5	8	2.5	5.5	2.5:1	8	70	4
AFS3-00102650-42-8P-4	0.1–26.5	18	2.5	4.2	2.5:1	8	120	4
AFS4-00102650-42-8P-4	0.1–26.5	22	2.5	4.2	2.5:1	8	135	4
AFS42-00102650-42-10P-42	0.1–26.5	30	2.75	4.2	2.5:1	10	200	42
AFS44-00102650-42-10P-44	0.1–26.5	35	3	4.2	2.5:1	10	275	44
NOTE: Noise figures increase below 500 MHz in bands greater than 0.1–10 GHz.								
MULTIOCTAVE BAND								
AFS1-00300140-10-10P-4	0.3–1.4	14	1	1	2:1	10	50	4
AFS2-00300140-09-10P-4	0.3–1.4	25	1	0.9	2:1	10	100	4
AFS3-00300140-09-10P-4	0.3–1.4	38	1	0.9	2:1	10	125	4
AFS4-00300140-09-10P-4	0.3–1.4	44	1	0.9	2:1	10	175	4
AFS2-00400350-12-10P-4	0.4–3.5	22	1.5	1.2	2:1	10	80	4
AFS3-00400350-12-10P-4	0.4–3.5	32	1	1.2	2:1	10	110	4
AFS4-00400350-12-10P-4	0.4–3.5	42	1	1.2	2:1	10	150	4
AFS5-00400350-12-10P-6	0.4–3.5	52	1.5	1.2	2:1	10	175	6
AFS1-00500200-10-10P-4	0.5–2	14	1.5	1	2:1	10	50	4
AFS2-00500200-08-15P-2	0.5–2	25	1	0.8	2:1	15	100	2
AFS3-00500200-08-15P-4	0.5–2	38	1	0.8	2:1	15	125	4
AFS4-00500200-08-15P-4	0.5–2	46	1	0.8	2:1	15	175	4
AFS1-01000400-13-10P-4	1–4	10	1.5	1.3	2:1	10	75	4
AFS2-01000400-10-10P-4	1–4	20	1	1	2:1	10	100	4
AFS3-01000400-10-10P-4	1–4	30	1.5	1	2:1	10	125	4
AFS4-01000400-10-10P-4	1–4	40	1.5	1	2:1	10	175	4
AFS1-02000600-20-5P-2	2–6	9	1	2	2:1	5	50	2
AFS2-02000600-09-8P-2	2–6	18	1	0.9	2:1	8	70	2
AFS3-02000600-09-10P-4	2–6	28	1	0.9	2:1	10	125	4
AFS4-02000600-09-10P-4	2–6	36	1	0.9	2:1	10	150	4
AFS1-02000800-20-S-2	2–8	8	1	2	2.5:1	5	50	2
AFS2-02000800-09-10P-2	2–8	18	1	0.9	2:1	10	70	2
AFS3-02000800-09-10P-4	2–8	26	1	1	2:1	10	125	4
AFS4-02000800-09-10P-4	2–8	34	1.5	0.9	2:1	10	150	4
AFS2-02001800-29-S-2	2–18	12	2.5	2.9	2.5:1	8	75	2
AFS3-02001800-24-10P-3	2–18	25	2	2.4	2.3:1	10	125	3
AFS4-02001800-23-10P-4	2–18	25	2	2.3	2:1	10	175	4
AFS5-02001800-24-10P-5	2–18	35	2.5	2.4	2.3:1	10	175	5
AFS2-06001800-25-5P-2	6–18	12	1.5	2.5	2:1	5	50	2
AFS3-06001800-24-10P-4	6–18	20	1.5	2.4	2:1	10	100	4
AFS4-06001800-22-10P-4	6–18	25	2	2.2	2:1	10	125	4
AFS5-06001800-22-10P-6	6–18	30	2	2.2	2:1	10	150	6
AFS6-06001800-22-10P-6	6–18	34	2	2.2	2:1	10	175	6
AFS2-08001800-25-5P-2	8–18	14	1.5	2.5	2:1	5	50	2
AFS3-08001800-24-8P-4	8–18	20	1.5	2.4	2:1	8	100	4
AFS4-08001800-22-10P-4	8–18	28	2	2.2	2:1	10	125	4
AFS5-08001800-22-13P-6	8–18	32	2	2.2	2:1	13	175	6
AFS6-08001800-22-15P-6	8–18	36	2	2.2	2:1	15	200	6
AFS3-12002600-32-5P-4	12–26	16	2.5	3.2	2.5:1	5	125	4
AFS32-12002600-32-5P-42	12–26	24	2.75	3.2	2.5:1	5	175	42
AFS33-12002600-32-5P-44	12–26	32	3	3.2	2.5:1	5	250	44

OCTAVE BAND AFS AMPLIFIERS

MODEL NUMBER	FREQUENCY RANGE (GHz)	GAIN (dB, Min.)	GAIN FLATNESS (±dB, Max.)	NOISE FIGURE (dB, Max.)	VSWR IN/OUT (Max.)	OUTPUT POWER @ 1 dB COMP. (dBm, Min.)	NOM. DC POWER (15 V, mA)	OUTLINE DRAWING
OCTAVE BAND								
AFS1-00120025-10-13P-4	0.12–0.25	15	0.75	1	2.5:1/2 :1	13	75	4
AFS2-00120025-09-10P-2	0.12–0.25	25	0.5	0.9	2:1	10	100	2
AFS3-00120025-09-10P-4	0.12–0.25	38	0.5	0.9	2:1	10	125	4
AFS4-00120025-09-10P-4	0.12–0.25	46	0.5	0.9	2:1	10	150	4
AFS1-00250050-09-10P-4	0.25–0.5	16	0.5	0.9	2:1	10	50	4
AFS2-00250050-08-10P-2	0.25–0.5	25	0.5	0.8	2:1	10	75	2
AFS3-00250050-08-10P-4	0.25–0.5	38	0.5	0.8	2:1	10	125	4
AFS4-00250050-08-10P-4	0.25–0.5	46	0.5	0.8	2:1	10	150	4
AFS1-00500100-08-10P-4	0.5–1	16	1	0.8	2:1	10	50	4
AFS2-00500100-06-10P-6	0.5–1	24	0.75	0.6	2:1/1.5:1	10	100	6
AFS3-00500100-06-10P-6	0.5–1	38	0.75	0.6	2:1/1.5:1	10	150	6
AFS4-00500100-06-10P-6	0.5–1	48	0.75	0.6	2:1/1.5:1	10	175	6
AFS1-01000200-11-15P-4	1–2	14	1	1.1	2:1	15	75	4
AFS2-01000200-05-10P-6	1–2	25	1	0.5	2:1	10	100	6
AFS3-01000200-05-10P-6	1–2	38	1	0.5	2:1	10	150	6
AFS4-01000200-05-10P-6	1–2	46	1	0.5	2:1	10	175	6
AFS1-01200240-09-10P-4	1.2–2.4	14	1	0.9	2:1	10	75	4
AFS2-01200240-09-8P-2	1.2–2.4	23	1	0.9	2:1	8	100	2
AFS3-01200240-06-10P-6	1.2–2.4	34	1	0.6	2:1	10	150	6
AFS4-01200240-06-10P-6	1.2–2.4	44	1	0.6	2:1	10	175	6
AFS1-02000400-12-10P-4	2–4	10	1	1.2	2:1	10	50	4
AFS2-02000400-07-8P-4	2–4	24	1	0.7	2:1	8	75	4
AFS3-02000400-06-10P-4	2–4	32	1	0.6	2:1	10	125	4
AFS4-02000400-06-10P-6	2–4	40	1.5	0.6	2:1	10	150	6
AFS1-02600520-18-5P-2	2.6–5.2	9	1	1.8	2:1	5	50	2
AFS2-02600520-14-8P-2	2.6–5.2	18	1	1.4	2:1	8	100	2
AFS3-02600520-10-10P-4	2.6–5.2	28	1	1	2:1	10	125	4
AFS4-02600520-10-10P-4	2.6–5.2	36	1	1	2:1	10	175	4
AFS1-04000800-13-5P-2	4–8	8	1	1.3	2:1	5	50	2
AFS2-04000800-08-8P-2	4–8	20	1	0.8	2:1	8	80	2
AFS3-04000800-07-10P-4	4–8	28	1	0.7	2:1	10	125	4
AFS4-04000800-08-10P-4	4–8	37	1	0.8	2:1	10	125	4
AFS2-05001000-18-5P-2	5–10	14	1	1.8	2:1	5	100	2
AFS3-05001000-14-8P-4	5–10	24	1	1.4	2:1	8	125	4
AFS4-05001000-14-10P-4	5–10	28	1.25	1.4	2:1	10	150	4
AFS5-05001000-14-10P-5	5–10	35	1.5	1.4	2:1	10	175	5
AFS2-06001200-18-5P-2	6–12	14	1.5	1.8	2:1	5	100	2
AFS3-06001200-15-8P-4	6–12	24	1.5	1.5	2:1	8	125	4
AFS4-06001200-15-10P-4	6–12	30	1.5	1.5	2:1	10	150	4
AFS5-06001200-15-10P-5	6–12	34	1.5	1.5	2:1	10	175	5
AFS42-06001200-15-10P-42	6–12	40	1.75	1.5	2:1	10	250	42
AFS1-08001200-15-5P-2	8–12	10	1	1.5	2:1	5	50	2
AFS2-08001200-14-5P-2	8–12	16	1	1.4	2:1	5	75	2
AFS3-08001200-09-10P-4	8–12	26	1	0.9	2:1	10	125	4
AFS4-08001200-10-10P-4	8–12	32	1	1	2:1	10	125	4
AFS42-08001200-10-10P-42	8–12	40	1.5	1	2:1	10	185	42
AFS2-08001600-15-5P-2	8–16	16	1.5	1.5	2:1	5	50	2
AFS3-08001600-15-8P-4	8–16	28	1	1.5	2:1	8	100	4
AFS4-08001600-15-10P-4	8–16	34	1	1.5	2:1	10	125	4
AFS5-08001600-15-10P-6	8–16	38	1	1.5	2:1	10	165	6
AFS6-08001200-15-10P-6	8–16	42	1.5	1.5	2:1	10	200	6

OCTAVE/MODERATE BAND AFS AMPLIFIERS

MODEL NUMBER	FREQUENCY RANGE (GHz)	GAIN (dB, Min.)	GAIN FLATNESS (±dB, Max.)	NOISE FIGURE (dB, Max.)	VSWR IN/OUT (Max.)	OUTPUT POWER @ 1 dB COMP. (dBm, Min.)	NOM. DC POWER (15 V, mA)	OUTLINE DRAWING
OCTAVE BAND (CONT.)								
AFS2-12001800-25-8P-2	12–18	12	1.5	2.5	2:1	8	75	2
AFS3-12001800-20-10P-4	12–18	20	1.5	2	2:1	10	100	4
AFS4-12001800-18-10P-4	12–18	28	1.5	1.8	2:1	10	125	4
AFS5-12001800-18-10P-6	12–18	36	1.5	1.8	2:1	10	150	6
AFS6-12001800-18-10P-6	12–18	40	1.75	1.8	2:1	10	200	6
AFS2-12002400-32-5P-2	12–24	10	1.5	3.2	2:1	5	40	2
AFS3-12002400-30-5P-4	12–24	18	1.5	3	2:1	8	60	4
AFS4-12002400-30-10P-4	12–24	24	2	3	2:1	10	85	4
AFS33-12002400-30-10P-44	12–24	36	2	3	2:1	10	120	44
AFS2-18002650-35-5P-2	18–26.5	10	1.75	3.5	2.2:1/2:1	5	50	2
AFS3-18002650-30-8P-4	18–26.5	18	1.75	3	2.2:1	8	125	4
AFS32-18002650-30-8P-42	18–26.5	30	2.5	3	2.2:1	8	175	42
AFS33-18002650-30-8P-44	18–26.5	38	3	3	2.2:1	8	200	44
MODERATE BAND								
AFS1-00240027-08-10P-4	0.24–0.27	16	0.25	0.8	2:1	10	50	4
AFS2-00240027-08-10P-2	0.24–0.27	28	0.25	0.8	2:1	10	75	2
AFS3-00240027-08-10P-4	0.24–0.27	38	0.25	0.8	2:1	10	100	4
AFS4-00240027-08-10P-4	0.24–0.27	46	0.5	0.8	2:1	10	150	4
AFS1-00500060-08-15P-4	0.5–0.6	17	0.25	0.8	1.5:1	15	100	4
AFS2-00500060-06-10P-6	0.5–0.6	25	0.25	0.6	1.5:1	10	125	6
AFS3-00500060-06-10P-6	0.5–0.6	38	0.25	0.6	1.5:1	10	150	6
AFS4-00500060-06-10P-6	0.5–0.6	46	0.5	0.6	1.5:1	10	175	6
AFS1-00700080-08-13P-4	0.7–0.8	16	0.5	0.8	1.5:1	13	80	4
AFS2-00700080-06-10P-6	0.7–0.8	28	0.5	0.6	1.5:1	10	90	6
AFS3-00700080-06-15P-6	0.7–0.8	42	0.5	0.6	1.5:1	15	150	6
AFS4-00700080-06-15P-6	0.7–0.8	52	0.5	0.6	1.5:1	15	175	6
AFS1-00800100-08-13P-4	0.8–1	16	0.5	0.8	1.5:1	13	80	4
AFS2-00800100-05-10P-6	0.8–1	30	0.5	0.5	1.5:1	10	90	6
AFS3-00800100-05-15P-6	0.8–1	44	0.5	0.5	1.5:1	15	150	6
AFS4-00800100-05-15P-6	0.8–1	54	0.5	0.5	1.5:1	15	175	6
AFS1-00900120-08-13P-4	0.9–1.2	16	0.5	0.8	1.5:1	13	80	4
AFS2-00900120-05-10P-6	0.9–1.2	28	0.5	0.5	1.5:1	10	90	6
AFS3-00900120-05-13P-6	0.9–1.2	40	0.5	0.5	1.5:1	13	150	6
AFS4-00900120-05-15P-6	0.9–1.2	50	0.5	0.5	1.5:1	15	175	6
AFS1-00950145-08-10P-4	0.95–1.45	16	0.5	0.8	1.5:1	10	80	4
AFS2-00950145-05-10P-6	0.95–1.45	28	0.5	0.5	1.5:1	10	90	6
AFS3-00950145-05-13P-6	0.95–1.45	40	0.5	0.5	1.5:1	13	150	6
AFS4-00950145-05-15P-6	0.95–1.45	50	0.5	0.5	1.5:1	15	175	6
AFS1-00950175-08-10P-4	0.95–1.75	14	0.5	0.8	1.5:1	10	80	4
AFS2-00950175-06-10P-6	0.95–1.75	26	0.5	0.6	1.5:1	10	90	6
AFS3-00950175-06-13P-6	0.95–1.75	38	0.5	0.6	1.5:1	13	150	6
AFS4-00950175-06-15P-6	0.95–1.75	50	0.5	0.6	1.5:1	15	175	6
AFS1-01100180-08-10P-4	1.1–1.8	16	0.5	0.8	1.7:1	10	80	4
AFS2-01100180-06-10P-6	1.1–1.8	28	0.5	0.6	1.7:1	10	90	6
AFS3-01100180-06-13P-6	1.1–1.8	40	0.5	0.6	1.7:1	13	150	6
AFS4-01100180-06-15P-6	1.1–1.8	50	0.5	0.6	1.7:1	15	175	6
AFS1-01200140-08-10P-4	1.2–1.4	14	1.5	0.8	2:1/2.5:1	10	80	4
AFS2-01200140-05-10P-6	1.2–1.4	28	0.5	0.5	1.5:1	10	90	6
AFS3-01200140-05-13P-6	1.2–1.4	40	0.5	0.5	1.5:1	13	150	6
AFS4-01200140-05-15P-6	1.2–1.4	50	0.5	0.5	1.5:1	15	175	6

MODERATE BAND AFS AMPLIFIERS

MODEL NUMBER	FREQUENCY RANGE (GHz)	GAIN (dB, Min.)	GAIN FLATNESS (±dB, Max.)	NOISE FIGURE (dB, Max.)	VSWR IN/OUT (Max.)	OUTPUT POWER @ 1 dB COMP. (dBm, Min.)	NOM. DC POWER (15 V, mA)	OUTLINE DRAWING
MODERATE BAND (CONT.)								
AFS1-01200160-08-10P-4	1.2–1.6	14	1.5	0.8	2:1/2.5:1	10	80	4
AFS2-01200160-05-10P-6	1.2–1.6	28	0.5	0.5	1.5:1	10	90	6
AFS3-01200160-05-13P-6	1.2–1.6	40	0.5	0.5	1.5:1	13	150	6
AFS4-01200160-05-15P-6	1.2–1.6	50	0.5	0.5	1.5:1	15	175	6
AFS1-01300140-08-10P-4	1.3–1.4	16	0.5	0.8	1.5:1	10	80	4
AFS2-01300140-05-10P-6	1.3–1.4	28	0.5	0.5	1.5:1	10	90	6
AFS3-01300140-05-13P-6	1.3–1.4	40	0.5	0.5	1.5:1	13	150	6
AFS4-01300140-05-15P-6	1.3–1.4	50	0.5	0.5	1.5:1	15	175	6
AFS1-01400170-08-10P-4	1.4–1.7	15	0.5	0.8	1.5:1	10	80	4
AFS2-01400170-06-10P-6	1.4–1.7	28	0.5	0.6	1.5:1	10	90	6
AFS3-01400170-06-13P-6	1.4–1.7	40	0.5	0.6	1.5:1	13	150	6
AFS4-01400170-06-13P-6	1.4–1.7	50	0.5	0.6	1.5:1	13	175	6
AFS1-01500160-08-10P-4	1.5–1.6	15	0.5	0.8	1.5:1	10	80	4
AFS2-01500160-05-10P-6	1.5–1.6	28	0.5	0.5	1.5:1	10	90	6
AFS3-01500160-05-13P-6	1.5–1.6	40	0.5	0.5	1.5:1	13	150	6
AFS4-01500160-05-13P-6	1.5–1.6	50	0.5	0.5	1.5:1	13	175	6
AFS1-01500180-08-10P-4	1.5–1.8	16	0.5	0.8	1.5:1	10	80	4
AFS2-01500180-06-10P-6	1.5–1.8	28	0.5	0.6	1.5:1	10	90	6
AFS3-01500180-06-13P-6	1.5–1.8	40	0.5	0.6	1.5:1	13	150	6
AFS4-01500180-06-13P-6	1.5–1.8	50	0.5	0.6	1.5:1	13	175	6
AFS1-01500250-08-10P-4	1.5–2.5	14	0.5	0.8	2:1	10	80	4
AFS2-01500250-06-10P-6	1.5–2.5	28	0.5	0.6	1.8:1	10	90	6
AFS3-01500250-06-13P-6	1.5–2.5	38	1	0.6	1.8:1	13	150	6
AFS4-01500250-06-13P-6	1.5–2.5	46	1	0.6	1.8:1	13	175	6
AFS1-01700190-08-10P-4	1.7–1.9	14	0.5	0.8	1.5:1	10	80	4
AFS2-01700190-06-10P-6	1.7–1.9	25	0.5	0.6	1.5:1	10	90	6
AFS3-01700190-06-13P-6	1.7–1.9	38	0.5	0.6	1.5:1	13	150	6
AFS4-01700190-06-13P-6	1.7–1.9	46	0.5	0.6	1.5:1	13	175	6
AFS1-01800220-08-10P-4	1.8–2.2	14	0.5	0.8	2:1	10	80	4
AFS2-01800220-06-10P-6	1.8–2.2	25	0.5	0.6	1.5:1	10	90	6
AFS3-01800220-06-13P-6	1.8–2.2	38	0.5	0.6	1.5:1	13	150	6
AFS4-01800220-06-13P-6	1.8–2.2	46	0.5	0.6	1.5:1	13	175	6
AFS1-02200230-08-10P-4	2.2–2.3	14	0.5	0.8	1.5:1	10	80	4
AFS2-02200230-06-10P-4	2.2–2.3	25	0.5	0.6	1.5:1	10	90	4
AFS3-02200230-06-13P-4	2.2–2.3	38	0.5	0.6	1.5:1	13	150	4
AFS4-02200230-06-13P-6	2.2–2.3	46	0.5	0.6	1.5:1	13	175	6
AFS1-02300270-08-10P-4	2.3–2.7	14	0.5	0.8	2:1	10	80	4
AFS2-02300270-06-10P-4	2.3–2.7	26	0.5	0.6	1.5:1	10	90	4
AFS3-02300270-06-13P-6	2.3–2.7	36	0.5	0.6	1.5:1	13	150	6
AFS4-02300270-06-13P-6	2.3–2.7	46	0.5	0.6	1.5:1	13	175	6
AFS1-02700290-09-8P-4	2.7–2.9	14	0.5	0.9	2:1	8	80	4
AFS2-02700290-06-8P-4	2.7–2.9	23	0.5	0.6	1.5:1	8	90	4
AFS3-02700290-06-13P-6	2.7–2.9	32	0.5	0.6	1.5:1	13	150	6
AFS4-02700290-06-13P-6	2.7–2.9	42	0.5	0.6	1.5:1	13	175	6
AFS1-02700300-10-8P-4	2.7–3.0	14	0.5	1	2:1	8	80	4
AFS2-02700300-06-8P-4	2.7–3.0	25	0.5	0.6	1.5:1	8	90	4
AFS3-02700300-06-13P-6	2.7–3.0	34	0.5	0.6	1.5:1	13	150	6
AFS4-02700300-06-13P-6	2.7–3.0	45	0.5	0.6	1.5:1	13	175	6
AFS1-02900310-10-5P-4	2.9–3.1	12	0.5	1	2:1	5	80	4
AFS2-02900310-06-10P-4	2.9–3.1	23	0.5	0.6	1.5:1	10	90	4
AFS3-02900310-06-13P-6	2.9–3.1	32	0.5	0.6	1.5:1	13	150	6
AFS4-02900310-06-13P-6	2.9–3.1	40	0.5	0.6	1.5:1	13	180	6
AFS6-02900310-06-13P-6	2.9–3.1	46	0.5	0.6	1.5:1	13	200	6

MODERATE BAND AFS AMPLIFIERS

MODEL NUMBER	FREQUENCY RANGE (GHz)	GAIN (dB, Min.)	GAIN FLATNESS (±dB, Max.)	NOISE FIGURE (dB, Max.)	VSWR IN/OUT (Max.)	OUTPUT POWER @ 1 dB COMP. (dBm, Min.)	NOM. DC POWER (15 V, mA)	OUTLINE DRAWING
MODERATE BAND (CONT.)								
AFS1-03000350-10-10P-4	3–3.5	10	0.5	1	2:1	10	80	4
AFS2-03000350-06-10P-4	3–3.5	23	0.5	0.6	1.5:1	10	90	4
AFS3-03000350-06-10P-4	3–3.5	29	0.5	0.6	1.5:1	10	150	4
AFS4-03000350-06-13P-6	3–3.5	36	0.5	0.6	1.5:1	13	175	6
AFS3-03100350-06-10P-4	3.1–3.5	29	0.5	0.6	1.5:1	10	150	4
AFS1-03400420-10-5P-4	3.4–4.2	10	0.5	1	2:1	5	100	4
AFS2-03400420-06-8P-4	3.4–4.2	20	0.5	0.6	1.75:1	8	150	4
AFS3-03400420-06-13P-4	3.4–4.2	28	0.5	0.6	1.75:1	13	175	4
AFS4-03400420-10-13P-6	3.4–4.2	40	0.5	1	1.5:1	13	200	6
AFS3-04300480-07-S-4	4.3–4.8	30	0.5	0.7	1.5:1	10	100	4
AFS4-04300480-07-S-4	4.3–4.8	38	0.5	0.7	1.5:1	10	125	4
AFS3-04400510-07-S-4	4.4–5.1	30	0.5	0.7	1.5:1	10	100	4
AFS4-04400510-07-S-4	4.4–5.1	38	0.5	0.7	1.5:1	10	125	4
AFS3-04500480-07-S-4	4.5–4.8	30	0.5	0.7	1.5:1	10	100	4
AFS4-04500480-07-S-4	4.5–4.8	38	0.5	0.7	1.5:1	10	125	4
AFS5-04500480-07-S-5	4.5–4.8	44	0.75	0.7	1.5:1	10	150	5
AFS3-05200600-07-10P-4	5.2–6	30	0.5	0.7	1.5:1	10	100	4
AFS4-05200600-07-S-4	5.2–6	38	0.5	0.7	1.5:1	10	125	4
AFS3-05400590-07-S-4	5.4–5.9	30	0.5	0.7	1.5:1	10	100	4
AFS4-05400590-07-S-4	5.4–5.9	38	0.5	0.7	1.5:1	10	125	4
AFS3-05800650-07-S-4	5.8–6.5	30	0.5	0.7	1.5:1	10	100	4
AFS4-05800650-07-S-4	5.8–6.5	38	0.5	0.7	1.5:1	10	125	4
AFS3-05800670-07-S-4	5.8–6.7	30	0.5	0.7	1.5:1	10	100	4
AFS4-05800670-07-S-4	5.8–6.7	38	0.5	0.7	1.5:1	10	125	4
AFS3-05900640-07-S-4	5.9–6.4	30	0.5	0.7	1.5:1	10	100	4
AFS4-05900640-07-S-4	5.9–6.4	38	0.5	0.7	1.5:1	10	125	4
AFS3-06400720-07-S-4	6.4–7.2	30	0.5	0.7	1.5:1	10	100	4
AFS4-06400720-07-S-4	6.4–7.2	38	0.5	0.7	1.5:1	10	125	4
AFS3-06700710-07-S-4	6.7–7.1	30	0.5	0.7	1.5:1	10	100	4
AFS4-06700710-07-S-4	6.7–7.1	38	0.5	0.7	1.5:1	10	125	4
AFS3-07250775-06-10P-4	7.25–7.75	30	0.5	0.6	1.5:1	10	100	4
AFS4-07250775-07-S-4	7.25–7.75	38	0.5	0.7	1.5:1	10	125	4
AFS3-07300840-07-S-4	7.3–8.4	30	0.5	0.7	1.5:1	10	100	4
AFS4-07300840-07-S-4	7.3–8.4	38	0.5	0.7	1.5:1	10	125	4
AFS3-07900840-07-S-4	7.9–8.4	30	0.5	0.7	1.5:1	10	100	4
AFS4-07900840-07-S-4	7.9–8.4	38	0.5	0.7	1.5:1	10	125	4
AFS3-08000850-07-S-4	8–8.5	30	0.5	0.7	1.5:1	10	100	4
AFS4-08000850-07-S-4	8–8.5	38	0.5	0.7	1.5:1	10	125	4
AFS3-08500960-09-S-4	8.5–9.6	26	0.5	0.9	1.5:1	10	100	4
AFS4-08500960-08-S-4	8.5–9.6	32	0.75	0.8	1.5:1	10	125	4
AFS3-08501160-09-S-4	8.5–11.6	26	0.5	1	1.5:1	10	100	4
AFS4-08501160-09-S-4	8.5–11.6	32	0.75	1	1.5:1	10	125	4
AFS3-09000920-08-S-4	9–9.2	26	0.5	0.9	1.5:1	10	100	4
AFS4-09000920-08-S-4	9–9.2	32	0.75	0.9	1.5:1	10	125	4
AFS3-09000950-08-S-4	9–9.5	26	0.5	0.8	1.5:1	10	100	4
AFS4-09000950-08-S-4	9–9.5	32	0.75	0.8	1.5:1	10	125	4

MODERATE BAND AFS AMPLIFIERS

MODEL NUMBER	FREQUENCY RANGE (GHz)	GAIN (dB, Min.)	GAIN FLATNESS (±dB, Max.)	NOISE FIGURE (dB, Max.)	VSWR IN/OUT (Max.)	OUTPUT POWER @ 1 dB COMP. (dBm, Min.)	NOM. DC POWER (15 V, mA)	OUTLINE DRAWING
MODERATE BAND (CONT.)								
AFS3-09001000-09-S-4	9–10	26	0.5	1	1.5:1	10	100	4
AFS4-09001000-09-S-4	9–10	32	0.75	1	1.5:1	10	125	4
AFS3-09001100-09-S-4	9–11	26	0.5	0.9	1.5:1	10	100	4
AFS4-09001100-09-S-4	9–11	32	0.75	0.9	1.5:1	10	125	4
AFS3-09300950-08-S-4	9.3–9.5	26	0.5	0.9	1.5:1	10	100	4
AFS4-09300950-08-S-4	9.3–9.5	32	0.75	0.9	1.5:1	10	125	4
AFS3-09501050-09-S-4	9.5–10.5	26	0.5	1	1.5:1	10	100	4
AFS4-09501050-09-S-4	9.5–10.5	32	0.75	1	1.5:1	10	125	4
AFS3-10501070-09-S-4	10.5–10.7	26	0.5	1	1.5:1	10	100	4
AFS4-10501070-09-S-4	10.5–10.7	32	0.75	1	1.5:1	10	125	4
AFS3-10701170-09-S-4	10.7–11.7	26	0.5	1	1.5:1	10	100	4
AFS4-10701170-09-S-4	10.7–11.7	32	0.75	1	1.5:1	10	125	4
AFS2-10701370-22-10P-4	10.7–13.7	15	0.75	2.2	1.5:1	10	150	4
AFS3-10701370-20-10P-6	10.7–13.7	26	0.75	2	1.5:1	10	200	6
AFS4-10701370-18-10P-6	10.7–13.7	32	0.75	1.8	1.5:1	10	250	6
AFS3-10951175-09-S-4	10.95–11.75	26	0.5	1	1.5:1	10	100	4
AFS4-10951175-09-S-4	10.95–11.75	32	0.75	0.9	1.5:1	10	125	4
AFS3-11701220-09-S-4	11.7–12.2	26	0.5	1.1	1.5:1	10	100	4
AFS4-11701220-09-5P-4	11.7–12.2	32	0.75	0.9	1.5:1	10	125	4
AFS2-12201280-14-5P-2	12.2–12.8	14	0.75	1.4	1.4:1/1.5:1	5	80	2
AFS3-12201280-13-12P-4	12.2–12.8	20	0.75	1.3	1.3:1/1.5:1	12	150	4
AFS4-12201280-13-12P-4	12.2–12.8	25	1.5	1.3	2:1	12	200	4
AFS2-12701330-16-5P-2	12.7–13.3	12	0.75	1.6	1.5:1	5	80	2
AFS3-12701330-15-10P-4	12.7–13.3	22	0.75	1.5	1.5:1	10	125	4
AFS4-12701330-15-10P-4	12.7–13.3	30	0.75	1.5	1.5:1	10	175	4
AFS2-13201400-17-5P-2	13.2–14	12	0.75	1.7	1.5:1	5	80	2
AFS3-13201400-16-10P-4	13.2–14	22	0.75	1.6	1.5:1	10	125	4
AFS4-13201400-16-10P-4	13.2–14	30	0.75	1.6	1.5:1	10	175	4
AFS2-14001450-16-10P-2	14–14.5	12	0.75	1.6	1.5:1	10	80	2
AFS3-14001450-15-10P-4	14–14.5	22	0.75	1.5	1.5:1	10	125	4
AFS4-14001450-15-10P-4	14–14.5	30	0.75	1.5	1.5:1	10	175	4
AFS2-14501550-17-8P-2	14.5–15.5	12	0.75	1.7	1.5:1	8	80	2
AFS3-14501550-16-10P-4	14.5–15.5	22	0.75	1.6	1.5:1	10	125	4
AFS4-14501550-16-10P-4	14.5–15.5	30	0.75	1.6	1.5:1	10	175	4
AFS2-17001750-19-8P-2	17–17.5	10	0.75	1.9	1.5:1	8	80	2
AFS3-17001750-17-10P-4	17–17.5	18	0.75	1.7	1.5:1	10	125	4
AFS4-17001750-17-10P-4	17–17.5	26	0.75	1.7	1.5:1	10	175	4
AFS2-20202120-30-5P-2	20.2–21.2	10	1	3	1.5:1	5	40	2
AFS3-20202120-25-8P-4	20.2–21.2	18	1	2.5	1.5:1	8	80	4
AFS4-20202120-25-8P-4	20.2–21.2	24	1	2.5	1.5:1	8	175	4
AFS2-21202400-35-5P-2	21.2–24	8	1	3.5	2:1	5	40	2
AFS3-21202400-28-8P-4	21.2–24	16	1	2.8	2:1	8	80	4
AFS4-21202400-28-10P-4	21.2–24	23	1	2.8	2:1	10	100	4

NOTE: Higher P1 dB and gains are available.

HIGHER POWER AFS AMPLIFIERS

MODEL NUMBER	FREQUENCY RANGE (GHz)	GAIN (dB, Min.)	GAIN FLATNESS (±dB, Max.)	NOISE FIGURE (dB, Max.)	VSWR IN/OUT (Max.)	OUTPUT POWER @ 1 dB COMP. (dBm, Min.)	NOM. DC POWER (15 V, mA)	OUTLINE DRAWING
HIGHER POWER								
AFS1-00010100-30-25P-4	0.01–1	16	1.5	3*	2.5:1	25	200	4
AFS2-00010100-30-25P-6	0.01–1	25	1.5	3*	2:1/2.5:1	25	250	6
AFS2-00050100-30-27P-6	0.05–1	28	1.5	3*	2:1/2.5:1	27	275	6
AFS3-00050100-25-27P-6	0.05–1	36	1.5	2.5*	2:1/2.5:1	27	300	6
AFS1-00100100-18-23P-4	0.1–1	13	1	1.8	2:1	23	175	4
AFS2-00100100-25-25P-6	0.1–1	22	2	2.5	2:1/2.5:1	25	225	6
AFS3-00100100-25-27P-6	0.1–1	33	2	2.5	2:1/2.5:1	27	300	6
AFS4-00100100-20-27P-6	0.1–1	44	2	2	2:1/2.5:1	27	350	6
AFS1-00100200-18-20P-4	0.1–2	12	1.75	1.8	2:1	20	175	4
AFS2-00100200-25-23P-2	0.1–2	22	1.5	2.5	2:1	23	225	2
AFS3-00100200-25-27P-6	0.1–2	34	1.5	2.5	2:1/2.5:1	27**	275	6
AFS4-00100200-25-27P-6	0.1–2	44	1.75	2.5	2:1/2.5:1	27	300	6
AFS2-00100300-30-20P-4	0.1–3	18	1.25	3	2:1	20	200	4
AFS3-00100300-25-23P-6	0.1–3	28	1.5	2.5	2:1/2.5:1	23	275	6
AFS4-00100300-20-23P-6	0.1–3	33	1.75	2	2.5:1	23	300	6
AFS2-00100400-35-20P-2	0.1–4	16	1.5	3.5	2.2:1	20	200	2
AFS3-00100400-26-20P-4	0.1–4	24	1.5	2.6	2:1	20	250	4
AFS4-00100400-25-20P-4	0.1–4	30	1.5	2.5	2:1	20	300	4
AFS5-00100400-25-20P-5	0.1–4	36	1.5	2.5	2:1	20	350	5
AFS2-00100600-35-20P-2	0.1–6	16	1.5	3.5	2.2:1	20	200	2
AFS3-00100600-26-20P-4	0.1–6	24	1.5	2.6	2:1	20	250	4
AFS4-00100600-25-20P-4	0.1–6	30	1.5	2.5	2:1	20	300	4
AFS5-00100600-25-20P-5	0.1–6	36	1.5	2.5	2:1	20	350	5
AFS2-00100800-50-20P-2	0.1–8	14	1.5	5	2.2:1	20	200	2
AFS3-00100800-30-20P-4	0.1–8	24	1.5	3	2:1	20	250	4
AFS4-00100800-28-20P-4	0.1–8	30	1.5	2.8	2:1	20	300	4
AFS5-00100800-28-20P-5	0.1–8	35	1.5	2.8	2:1	20	350	5
AFS2-00101000-55-20P-2	0.1–10	10	1.5	5.5	2.2:1	20	200	2
AFS3-00101000-40-20P-4	0.1–10	18	1.5	4.5	2:1	20	250	4
AFS4-00101000-40-20P-4	0.1–10	27	1.5	4	2:1	20	300	4
AFS5-00101000-40-20P-5	0.1–10	35	2	4	2:1	20	350	5
AFS2-00101200-55-20P-2	0.1–12	10	2	5.5	2.2:1	20	200	2
AFS4-00101200-40-20P-4	0.1–12	27	2	4	2:1	20	300	4
AFS42-00101200-S-20P-42	0.1–12	35	2.25	4.5	2:1	20	350	42
AFS3-00501800-60-20P-4	0.5–18**	20	2.5	6	2.5:1/2.2:1	20	300	4
AFS4-00501800-60-20P-6	0.5–18**	25	2.75	6	2.5:1/2.2:1	20	350	6
AFS5-00501800-55-20P-6	0.5–18**	30	2.75	5.5	2.5:1/2.2:1	20	400	6
AFS8-00501800-55-20P-8	0.5–18**	38	2.75	5.5	2.5:1/2.2:1	20	450	8
AFS3-00502000-80-18P-4	0.5–20**	18	2.5	8	2.5:1/2.2:1	18	350	4
AFS5-00502000-60-18P-6	0.5–20**	25	3	6	2.5:1/2.2:1	18	360	6
AFS6-00502000-50-18P-6	0.5–20**	36	3	5	2.5:1/2.2:1	18	400	6
AFS1-01000200-16-20P-4	1–2	14	0.75	1.6	2:1	20	150	4
AFS2-01000200-20-23P-2	1–2	20	1.5	2	2:1	23	200	2
AFS3-01000200-25-27P-6	1–2	32	1.5	2.5	2:1	27	350	6
AFS2-02000400-35-20P-4	2–4	20	1.5	3.5	2:1	20	200	4
AFS4-02000400-30-25P-6	2–4	34	1.5	3	2:1	25	250	6

NOTE: Noise figure increases below 500 MHz in bands wider than 0.1–10 GHz.

* Noise figure degrades below 100 MHz. Please contact factory for details.

** Usable to 0.1 GHz.

HIGHER POWER AFS AMPLIFIERS (CONT.)

MODEL NUMBER	FREQUENCY RANGE (GHz)	GAIN (dB, Min.)	GAIN FLATNESS (±dB, Max.)	NOISE FIGURE (dB, Max.)	VSWR IN/OUT (Max.)	OUTPUT POWER @ 1 dB COMP. (dBm, Min.)	NOM. DC POWER (15 V, mA)	OUTLINE DRAWING
HIGHER POWER (CONT.)								
AFS2-04000800-40-20P-2	4-8	14	1	4	2:1	20	150	2
AFS3-04000800-40-20P-4	4-8	20	1	4	2:1	20	200	4
AFS4-04000800-25-22P-4	4-8	28	1.25	2.5	2:1	22	275	4
AFS5-04000800-25-22P-5	4-8	34	1.25	2.5	2:1	22	300	5
AFS3-08001200-35-20P-4	8-12	20	1.25	3.5	2:1	20	125	4
AFS4-08001200-40-20P-4	8-12	22	1.25	4	2:1	20	200	4
AFS5-08001200-S-20P-5	8-12	30	1.5	3	2:1	20	200	5
AFS42-08001200-30-20P-42	8-12	36	1.5	3	2:1	20	250	42
AFS3-12001800-50-20P-4	12-18	18	1.25	5	2:1	20	275	4
AFS6-12001800-40-20P-6	12-18	28	2	4	2:1	20	375	6
AFS8-12001800-40-20P-8	12-18	36	1.5	4	2:1	20	400	8
AFS3-08001800-60-21P-4	8-18	18	2	6	2:1	21	275	4
AFS5-08001800-40-21P-6	8-18	26	2.5	4	2:1	21	400	6
AFS8-08001800-40-21P-8	8-18	34	2.5	4	2:1	21	450	8
AFS5-06001800-50-20P-6	6-18	23	2	5	2:1	20	365	6
AFS7-06001800-50-20P-8	6-18	35	2.5	5	2:1	20	400	8
AFS1-02001800-80-20P-2	2-18	8	1.5	8	2.5:1/2:1	20	275	2
AFS3-02001800-60-20P-4	2-18	20	2	6	2.5:1/2:1	20	300	4
AFS4-02001800-60-20P-6	2-18	25	2.5	6	2.5:1/2:1	20	350	6
AFS6-02001800-60-20P-8	2-18	35	2.75	6	2.5:1/2:1	20	400	8

AFS SERIES TYPICAL DATA

AFS3-00100600-13-10P-4

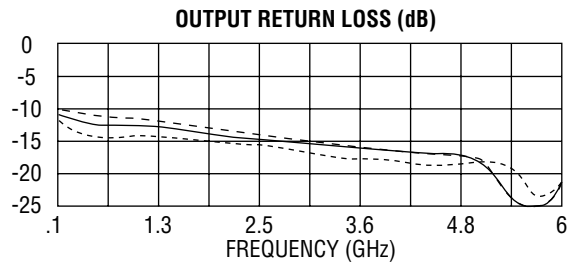
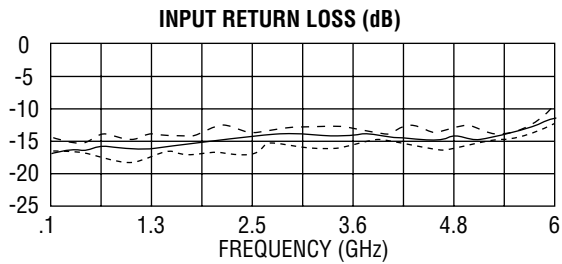
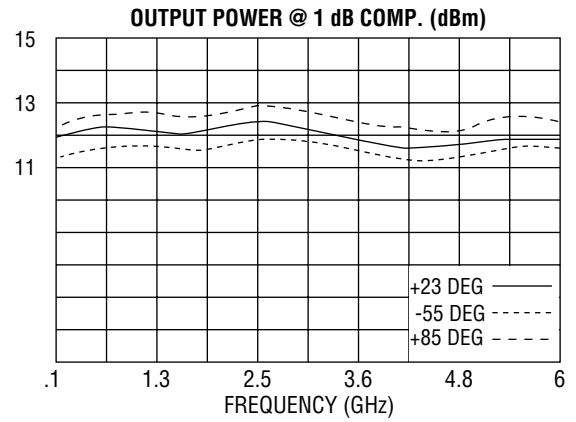
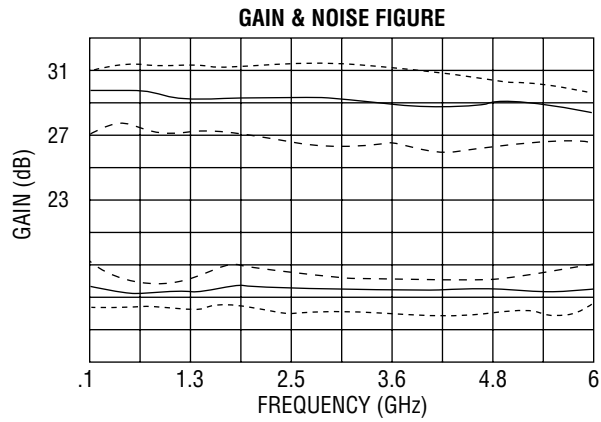

AFS3-08001200-09-10P-4

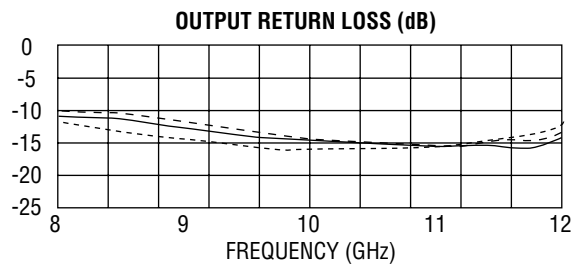
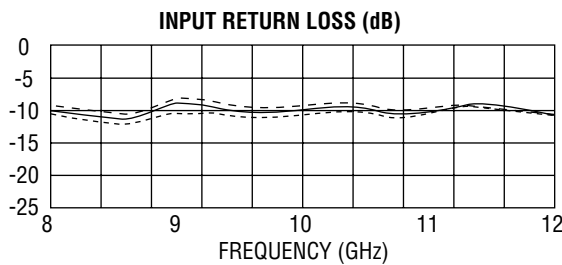
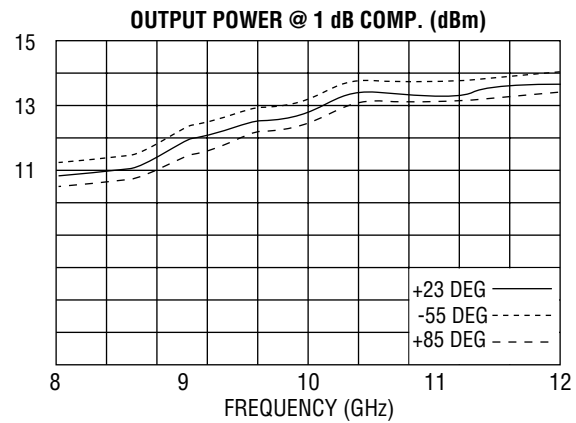
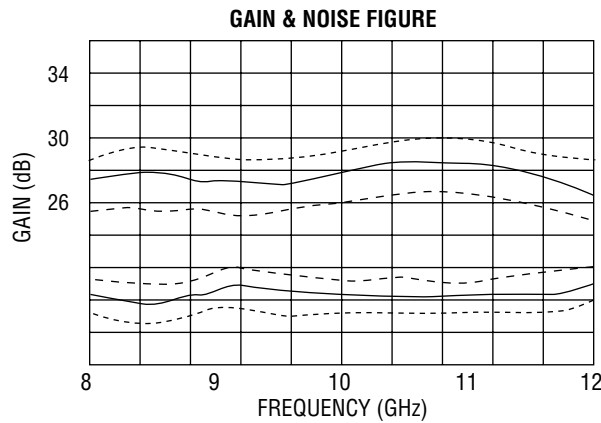

AFS SERIES TYPICAL DATA

AFS4-12001800-18-10P-4

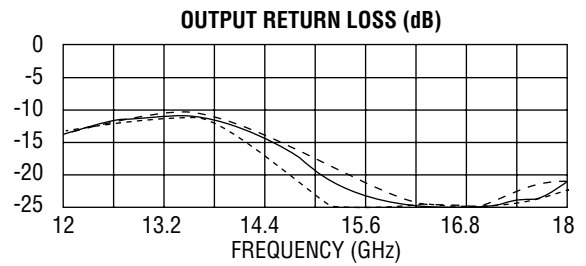
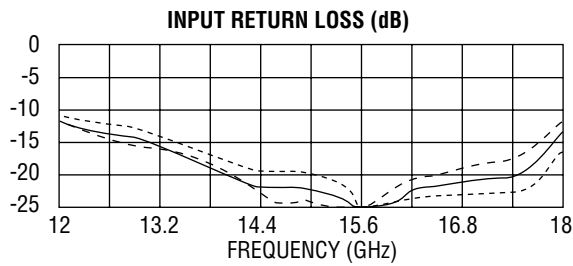
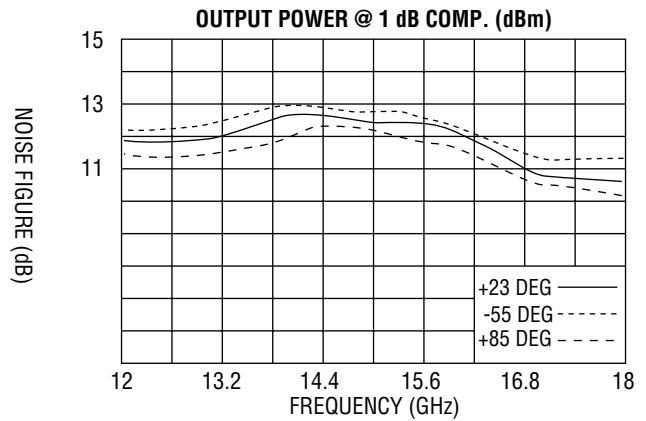
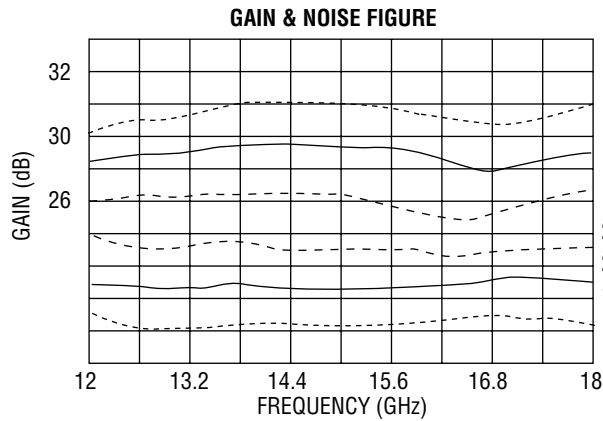

AFS4-02001800-22-10P-4

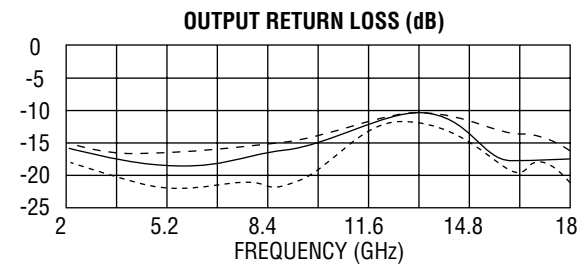
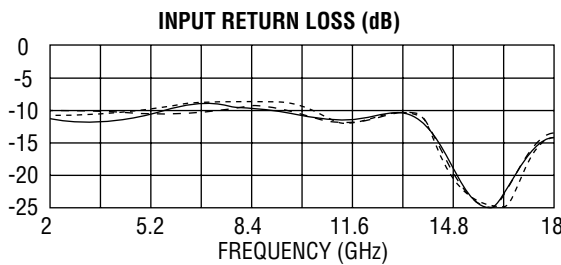
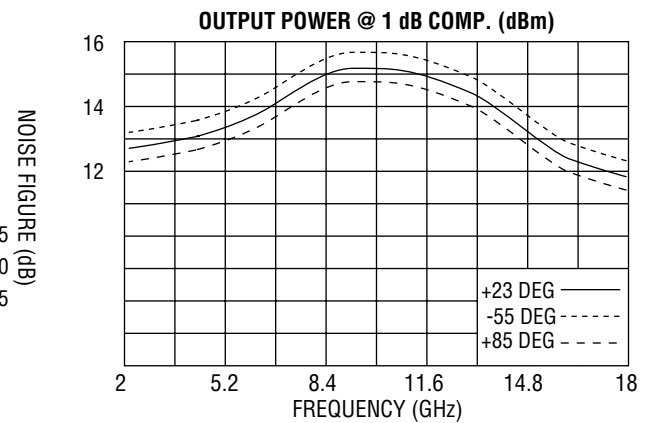
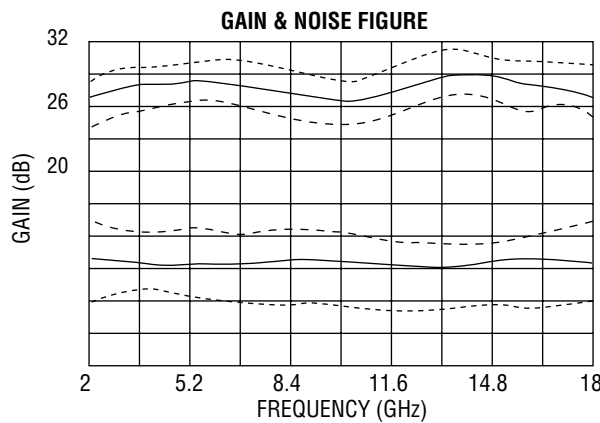

AFS SERIES TYPICAL DATA

AFS3-02001800-70-20P-4

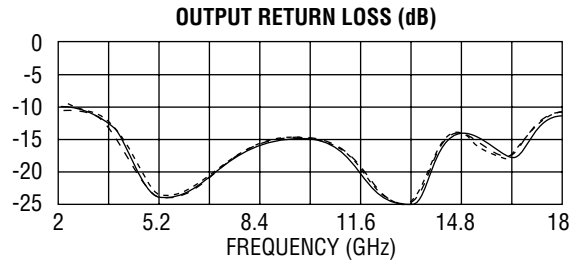
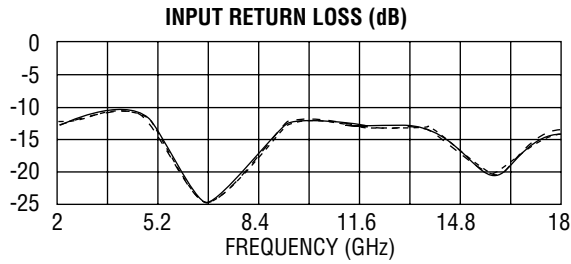
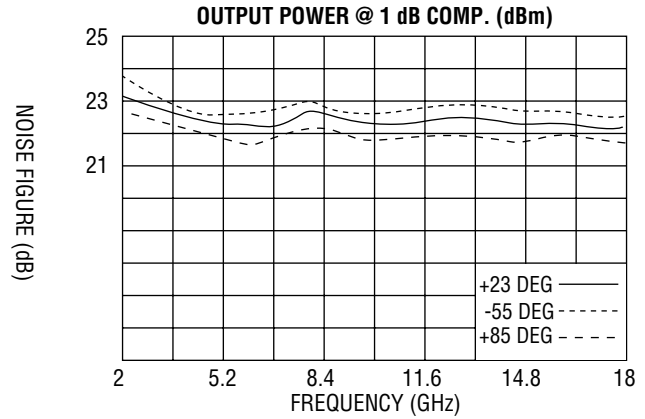
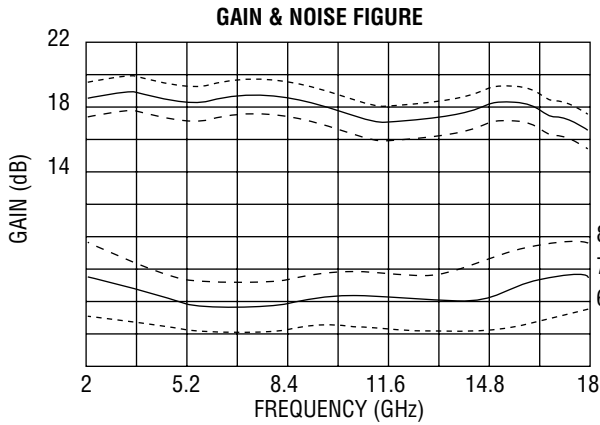

AFS4-00102000-30-10P-4

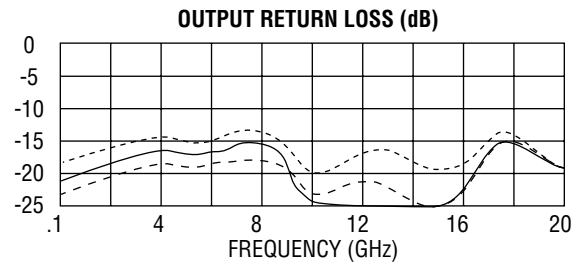
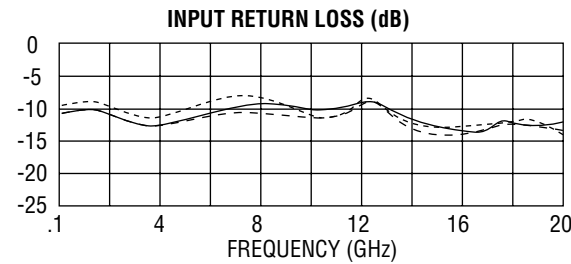
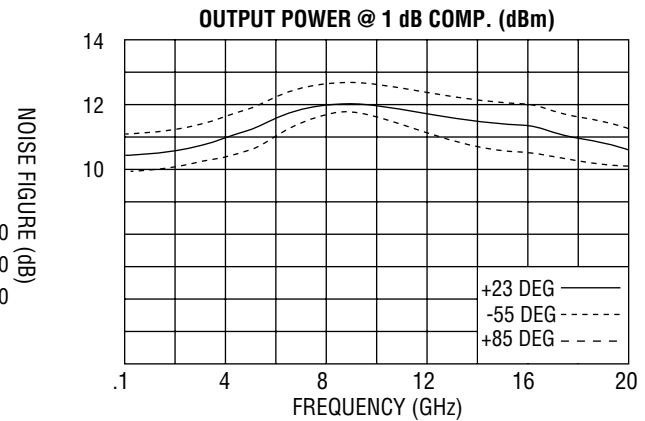
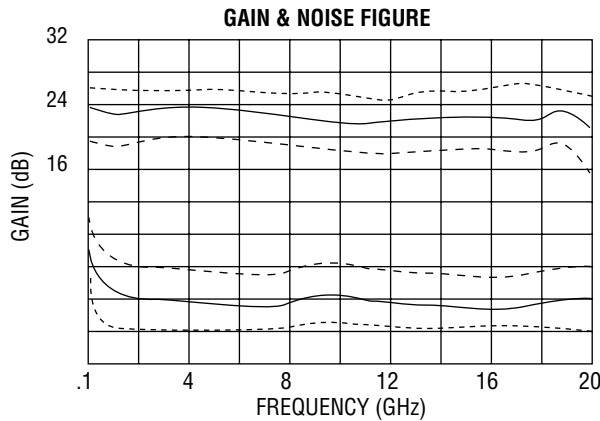

LOW-NOISE AFD AMPLIFIERS

MODEL NUMBER	FREQUENCY RANGE (GHz)	GAIN (dB, Min.)	GAIN FLATNESS (\pm dB, Max.)	NOISE FIGURE (dB, Max.)	VSWR IN/OUT (Max.)	OUTPUT POWER @ 1 dB COMP. (dBm, Min.)	NOM. DC POWER (15 V, mA)
LOW-NOISE							
AFD3-005007-09	0.5–0.7	38	0.35	0.9	1.5:1	10	125
AFD3-005020-13	0.5–2	34	1	1.3	2:1	10	150
AFD3-006007-09	0.6–0.7	38	0.25	0.9	1.5:1	10	125
AFD3-006008-10	0.6–0.8	38	0.35	1	1.5:1	10	125
AFD3-007008-09	0.7–0.8	38	0.25	0.9	1.5:1	10	125
AFD3-007012-10	0.7–1.2	36	0.5	1	1.5:1	10	125
AFD3-008010-10	0.8–1	36	0.35	1	1.5:1	10	125
AFD3-012013-07	1.2–1.3	36	0.25	0.7	1.5:1	10	125
AFD3-012014-07	1.2–1.4	36	0.35	0.7	1.5:1	10	125
AFD3-013014-07	1.3–1.4	36	0.25	0.7	1.5:1	10	125
AFD3-014015-07	1.4–1.5	36	0.25	0.7	1.5:1	10	125
AFD3-014016-07	1.4–1.6	36	0.35	0.7	1.5:1	10	125
AFD3-014024-08	1.4–2.4	34	0.5	0.8	1.5:1	10	125
AFD3-015016-06	1.5–1.6	36	0.25	0.6	1.5:1	10	125
AFD3-015017-07	1.5–1.7	36	0.25	0.7	1.5:1	10	125
AFD3-015020-08	1.5–2	36	0.5	0.8	1.5:1	10	125
AFD3-015030-12	1.5–3	30	1	1.2	2:1	10	125
AFD3-016017-06	1.6–1.7	36	0.25	0.6	1.5:1	10	125
AFD3-016018-07	1.6–1.8	36	0.35	0.7	1.5:1	10	125
AFD3-017018-06	1.7–1.8	36	0.25	0.6	1.5:1	10	125
AFD3-017024-10	1.7–2.4	34	0.5	1	2:1/1.5:1	10	125
AFD3-018019-07	1.8–1.9	36	0.25	0.7	1.5:1	10	125
AFD3-018020-08	1.8–2	36	0.35	0.8	1.5:1	10	125
AFD3-020021-07	2–2.1	36	0.25	0.7	1.5:1	10	125
AFD3-020022-07	2–2.2	34	0.35	0.7	1.5:1	10	125
AFD3-020025-08	2–2.5	34	0.5	0.8	1.5:1	10	125
AFD3-021022-07	2.1–2.2	34	0.25	0.7	1.5:1	10	125
AFD3-022023-07	2.2–2.3	34	0.25	0.7	1.5:1	10	125
AFD3-022024-08	2.2–2.4	34	0.35	0.8	1.5:1	10	125
AFD3-023027-08	2.3–2.7	34	0.35	0.8	1.5:1	10	125
AFD3-024026-08	2.4–2.6	32	0.35	0.8	1.5:1/1.3:1	10	125
AFD3-025030-08	2.5–3	32	0.5	0.8	1.5:1	10	125
AFD3-027029-08	2.7–2.9	32	0.35	0.8	1.5:1/1.3:1	10	125
AFD3-027031-08	2.7–3.1	30	0.35	0.8	1.5:1/1.3:1	10	125
AFD3-029031-08	2.9–3.1	30	0.35	0.8	1.5:1/1.3:1	10	125
AFD3-030035-08	3–3.5	30	0.5	0.8	1.5:1	10	125
AFD3-031033-08	3.1–3.3	30	0.5	0.8	1.5:1	10	125
AFD3-037042-08	3.7–4.2	30	0.5	0.8	1.5:1	10	125
AFD2-005010-10	.5–1	25	1	1	2:1	5	100
AFD3-005010-07	.5–1	36	1	0.7	2:1	10	150
AFD4-005010-07	.5–1	45	1.5	0.7	2:1	10	175
AFD2-010020-10	1–2	25	0.75	1	2:1	8	100
AFD3-010020-06	1–2	36	1	0.6	2:1	10	150
AFD4-010020-06	1–2	44	1.25	0.6	2:1	10	175
AFD2-010040-20	1–4	22	1	2	2:1	10	100
AFD3-010040-20	1–4	32	1.5	2	2:1	10	150
AFD4-010040-20	1–4	36	1.5	2	2:1	10	175
AFD2-020040-15	2–4	24	1	1.5	2:1	5	30
AFD3-020040-09	2–4	34	1	0.9	2:1	10	150
AFD4-020040-09	2–4	40	1.5	0.9	2:1	10	220

NOTE: Please contact factory for exact outline dimensions.

LOW-NOISE/HIGHER POWER AFD AMPLIFIERS

MODEL NUMBER	FREQUENCY RANGE (GHz)	GAIN (dB, Min.)	GAIN FLATNESS (±dB, Max.)	NOISE FIGURE (dB, Max.)	VSWR IN/OUT (Max.)	OUTPUT POWER @ 1 dB COMP. (dBm, Min.)	NOM. DC POWER (15 V, mA)
LOW-NOISE (CONT.)							
AFD1-020045-20	2-4.5	10	0.7	2	2:1	5	50
AFD2-020045-15	2-4.5	20	1	1.5	2:1	5	100
AFD3-020045-15	2-4.5	30	1.5	1.5	2:1	10	160
AFD4-020045-15	2-4.5	40	1.5	1.5	2:1	10	260
AFD1-020060-30	2-6	8	0.75	3	2:1	8	50
AFD2-020060-25	2-6	17	1	2.5	2:1	8	100
AFD3-020060-25	2-6	26	1.25	2.5	2:1	10	160
AFD4-020060-25	2-6	35	1.5	2.5	2:1	10	220
AFD5-020060-25	2-6	44	1.75	2.5	2:1	10	280
AFD1-020080-30	2-8	8	0.75	3	2:1	8	50
AFD2-020080-25	2-8	16	1	2.5	2:1	8	100
AFD3-020080-25	2-8	24	1.5	2.5	2:1	10	160
AFD4-020080-25	2-8	33	1.5	2.5	2:1	10	220
AFD5-020080-25	2-8	41	1.75	2.5	2:1	10	280
AFD1-040080-25	4-8	8	0.5	2.5	2:1	5	40
AFD2-040080-23	4-8	17	0.75	2.3	2:1	8	80
AFD3-040080-23	4-8	27	1	2.3	2:1	12	150
AFD4-040080-23	4-8	34	1.5	2.3	2:1	12	220
AFD5-040080-23	4-8	42	1.75	2.3	2:1	12	290
AFD1-040120-45	4-12	6	1	4.5	2:1	5	100
AFD2-040120-30	4-12	13	1	3	2:1	10	120
AFD3-040120-30	4-12	19	1.25	3	2:1	10	180
AFD4-040120-30	4-12	25	1.5	3	2:1	10	260
AFD5-040120-30	4-12	31	1.75	3	2:1	10	300
AFD6-040120-30	4-12	37	2	3	2:1	10	360
AFD1-080120-35	8-12	6	1	3.5	2:1	5	50
AFD2-080120-30	8-12	13	1	3	2:1	10	120
AFD3-080120-25	8-12	19	1	2.5	2:1	12	180
AFD4-080120-25	8-12	25	1	2.5	2:1	12	240
AFD5-080120-25	8-12	31	1.25	2.5	2:1	12	300
AFD6-080120-25	8-12	37	1.5	2.5	2:1	12	360
HIGHER POWER							
AFD1-005010-17P	0.5-1	13	1	3	2:1	17	125
AFD1-005010-20P	0.5-1	12	1	3	2:1	20	150
AFD1-005010-23P	0.5-1	12	1	3.5	2:1	23	175
AFD1-005010-25P	0.5-1	12	1	4.5	2:1	25	190
AFD1-005010-30P	0.5-1	10	1.5	5	2:1	20	500
AFD2-005010-17P	0.5-1	26	1.5	3	2:1	17	200
AFD2-005010-20P	0.5-1	24	1.5	3	2:1	20	250
AFD2-005010-23P	0.5-1	24	1.5	3.5	2:1	23	275
AFD2-005010-25P	0.5-1	24	1.5	3.5	2:1	25	280
AFD3-005010-17P	0.5-1	35	1.5	2	2:1	17	250
AFD3-005010-20P	0.5-1	33	1.5	2	2:1	20	300
AFD3-005010-23P	0.5-1	33	1.5	2.5	2:1	23	330
AFD3-005010-25P	0.5-1	33	1.5	3	2:1	25	330
AFD1-010020-17P	1-2	11	0.75	3.5	2:1	17	125
AFD1-010020-20P	1-2	11	0.75	3.5	2:1	20	150
AFD1-010020-23P	1-2	11	0.75	4	2:1	23	175
AFD1-010020-25P	1-2	11	0.75	4.5	2:1	25	190
AFD2-010020-17P	1-2	25	1.25	3.5	2:1	17	200
AFD2-010020-20P	1-2	25	1.25	3.5	2:1	20	250
AFD2-010020-23P	1-2	25	1.25	4	2:1	23	275
AFD2-010020-25P	1-2	25	1.25	4	2:1	25	280
AFD3-010020-17P	1-2	33	1.5	2.5	2:1	17	250
AFD3-010020-20P	1-2	33	1.5	3	2:1	10	300
AFD3-010020-23P	1-2	30	1.5	3	2:1	23	325
AFD3-010020-25P	1-2	30	1.5	3	2:1	25	330
AFD3-010020-30P	1-2	30	1.5	3	2:1	30	675

NOTE: Please contact factory for exact outline dimensions.

HIGHER POWER AFD AMPLIFIERS

MODEL NUMBER	FREQUENCY RANGE (GHz)	GAIN (dB, Min.)	GAIN FLATNESS (±dB, Max.)	NOISE FIGURE (dB, Max.)	VSWR IN/OUT (Max.)	OUTPUT POWER @ 1 dB COMP. (dBm, Min.)	NOM. DC POWER (15 V, mA)
HIGHER POWER (CONT.)							
AFD1-010040-15P	1-4	7	1	6	2:1	15	100
AFD1-010040-20P	1-4	6	1	7	2:1	20	160
AFD1-010040-23P	1-4	6	1	8	2:1	23	190
AFD2-010040-15P	1-4	15	1.25	5	2:1	15	160
AFD2-010040-20P	1-4	13	1.25	6	2:1	20	250
AFD2-010040-23P	1-4	13	1.25	7	2:1	23	270
AFD3-010040-15P	1-4	24	1.5	5	2:1	15	210
AFD3-010040-20P	1-4	22	1.5	5	2:1	20	300
AFD3-010040-23P	1-4	22	1.5	6	2:1	23	320
AFD4-010040-15P	1-4	33	2	4	2:1	15	250
AFD4-010040-20P	1-4	31	2	4	2:1	20	350
AFD4-010040-23P	1-4	31	2	5	2:1	23	370
AFD1-020040-17P	2-4	9	0.75	5	2:1	17	125
AFD1-020040-20P	2-4	8	0.75	5.5	2:1	20	150
AFD1-020040-23P	2-4	8	0.75	6	2:1	23	200
AFD1-020040-25P	2-4	7	0.75	6	2:1	25	275
AFD2-020040-17P	2-4	18	1.5	5	2:1	17	200
AFD2-020040-20P	2-4	16	1.5	5.5	2:1	20	250
AFD2-020040-23P	2-4	16	1	5.5	2:1	23	300
AFD2-020040-25P	2-4	15	1.25	6	2:1	25	375
AFD3-020040-17P	2-4	27	1.25	4	2:1	17	250
AFD3-020040-20P	2-4	24	1.25	4.5	2:1	20	300
AFD3-020040-23P	2-4	24	1.25	4.5	2:1	23	350
AFD3-020040-25P	2-4	24	1.25	5	2:1	25	425
AFD4-020040-17P	2-4	36	1.5	4	2:1	17	300
AFD4-020040-20P	2-4	32	1.5	4	2:1	20	350
AFD4-020040-23P	2-4	32	1.5	4	2:1	23	400
AFD4-020040-25P	2-4	32	1.5	4	2:1	25	475
AFD1-020060-15P	2-6	7	1	5.5	2:1	15	100
AFD1-020060-20P	2-6	6	1	6.5	2:1	20	160
AFD1-020060-23P	2-6	5	1	7.5	2:1	23	190
AFD2-020060-15P	2-6	15	1	4.5	2:1	15	160
AFD2-020060-20P	2-6	13	1.25	5.5	2:1	20	250
AFD2-020060-23P	2-6	11	1.25	6.5	2:1	23	270
AFD3-020060-15P	2-6	24	1	3.5	2:1	15	210
AFD3-020060-20P	2-6	22	1.5	4.5	2:1	20	300
AFD3-020060-23P	2-6	20	1.5	5.5	2:1	23	320
AFD4-020060-15P	2-6	32	1.25	3.5	2:1	15	260
AFD4-020060-20P	2-6	30	2	4.5	2:1	20	350
AFD4-020060-23P	2-6	28	2	4.5	2:1	23	370
AFD1-020080-15P	2-8	7	1	5.5	2:1	15	100
AFD1-020080-20P	2-8	6	1	6.5	2:1	20	160
AFD1-020080-23P	2-8	5	1	7.5	2:1	23	190
AFD2-020080-15P	2-8	15	1	5.5	2:1	15	160
AFD2-020080-20P	2-8	13	1.25	5.5	2:1	20	250
AFD2-020080-23P	2-8	11	1.25	6.5	2:1	23	270
AFD3-020080-15P	2-8	24	1.5	3.5	2:1	15	210
AFD3-020080-20P	2-8	22	1.5	4.5	2:1	20	300
AFD3-020080-23P	2-8	20	1	5.5	2:1	23	320
AFD4-020080-15P	2-8	32	1.25	4.5	2:1	15	260
AFD4-020080-20P	2-8	30	2	4.5	2:1	20	350
AFD4-020080-23P	2-8	28	2	3.5	2:1	23	370
AFD5-020080-15P	2-8	40	2	4.5	2:1	15	300
AFD5-020080-20P	2-8	38	2	4.5	2:1	20	390
AFD5-020080-23P	2-8	36	2	4.5	2:1	23	420

NOTE: Please contact factory for exact outline dimensions.

HIGHER POWER AFD AMPLIFIERS

MODEL NUMBER	FREQUENCY RANGE (GHz)	GAIN (dB, Min.)	GAIN FLATNESS (\pm dB, Max.)	NOISE FIGURE (dB, Max.)	VSWR IN/OUT (Max.)	OUTPUT POWER @ 1 dB COMP. (dBm, Min.)	NOM. DC POWER (15 V, mA)
HIGHER POWER (CONT.)							
AFD1-040080-17P	4-8	7	0.75	4.5	2:1	17	125
AFD1-040080-20P	4-8	7	0.75	6.5	2:1	20	150
AFD1-040080-23P	4-8	5	0.75	7.5	2:1	23	200
AFD1-040080-25P	4-8	6	0.75	7.5	2:1	25	275
AFD2-040080-17P	4-8	14	1	4	2:1	17	200
AFD2-040080-20P	4-8	14	1	5.5	2:1	20	250
AFD2-040080-23P	4-8	13	1	6.5	2:1	23	300
AFD2-040080-25P	4-8	12	1	6.5	2:1	25	375
AFD3-040080-17P	4-8	23	1	3.5	2:1	17	250
AFD3-040080-20P	4-8	23	1	4.5	2:1	20	300
AFD3-040080-23P	4-8	20	1	5.5	2:1	23	350
AFD3-040080-25P	4-8	20	1	5.5	2:1	25	425
AFD4-040080-17P	4-8	31	1.25	3.5	2:1	17	300
AFD4-040080-20P	4-8	31	1.25	4.5	2:1	20	350
AFD4-040080-23P	4-8	27	1.25	4.5	2:1	23	400
AFD4-040080-25P	4-8	27	1.25	4.5	2:1	25	475
AFD5-040080-17P	4-8	38	1.5	3.5	2:1	17	350
AFD5-040080-20P	4-8	38	1.5	4.5	2:1	20	400
AFD5-040080-23P	4-8	36	1.5	4.5	2:1	23	450
AFD5-040080-25P	4-8	36	1.5	4.5	2:1	25	525
AFD1-040120-15P	4-12	5	1	6.5	2:1	15	100
AFD2-040120-15P	4-12	10	1.25	5.5	2:1	15	275
AFD2-040120-20P	4-12	8	1.25	6.5	2:1	20	275
AFD2-040120-23P	4-12	8	1.25	6.5	2:1	23	300
AFD3-040120-15P	4-12	16	1.5	5.5	2:1	15	200
AFD3-040120-20P	4-12	14	1.5	5.5	2:1	20	280
AFD3-040120-23P	4-12	13	1.5	6.5	2:1	23	260
AFD4-040120-15P	4-12	23	1.75	5.5	2:1	15	250
AFD4-040120-20P	4-12	20	1.75	5.5	2:1	20	340
AFD4-040120-23P	4-12	19	1.75	5.5	2:1	23	320
AFD5-040120-15P	4-12	29	1.75	5.5	2:1	15	300
AFD5-040120-20P	4-12	26	2	5.5	2:1	20	400
AFD5-040120-23P	4-12	25	2	5.5	2:1	23	370
AFD6-040120-15P	4-12	35	2	5.5	2:1	15	350
AFD6-040120-20P	4-12	32	2	5.5	2:1	20	460
AFD6-040120-23P	4-12	31	2	5.5	2:1	23	420
AFD1-050100-15P	5-10	6	0.75	5.5	2:1	15	100
AFD1-050100-20P	5-10	5	0.75	6	2:1	20	170
AFD1-050100-23P	5-10	5	0.75	6	2:1	23	190
AFD2-050100-15P	5-10	12	1	4.5	2:1	15	150
AFD2-050100-20P	5-10	11	1	5	2:1	20	220
AFD2-050100-23P	5-10	10	1	6	2:1	23	280
AFD3-050100-15P	5-10	19	1.25	4.5	2:1	15	200
AFD3-050100-20P	5-10	18	1.25	5	2:1	20	280
AFD3-050100-23P	5-10	16	1.25	5	2:1	23	340
AFD4-050100-15P	5-10	26	1.5	4.5	2:1	15	250
AFD4-050100-20P	5-10	25	1.5	5	2:1	20	340
AFD4-050100-23P	5-10	23	1.5	5	2:1	23	400
AFD5-050100-15P	5-10	33	1.75	5	2:1	15	300
AFD5-050100-20P	5-10	32	1.75	5	2:1	20	400
AFD5-050100-23P	5-10	30	1.75	5	2:1	23	460
AFD6-050100-15P	5-10	40	2	4.5	2:1	15	350
AFD6-050100-20P	5-10	39	2	5	2:1	20	460
AFD6-050100-23P	5-10	37	2	5	2:1	23	520

NOTE: Please contact factory for exact outline dimensions.

LOW, ULTRA-LOW NOISE AND MEDIUM POWER AFS AMPLIFIERS

MODEL NUMBER	FREQUENCY RANGE (GHz)	GAIN (dB, Min.)	GAIN VARIATION (±dB, Max.)	NOISE FIGURE (dB, Max.)	VSWR IN/OUT (Max.)	OUTPUT POWER @ 1 dB COMP. (dBm, Min.)	OUTLINE DRAWING
AFS2-00500100-10-ULN	0.5-1	23	1	1	2:1	10	2
AFS3-01000200-10-ULN	1-2	34	1	1	2:1	10	4
AFS3-02000400-10-ULN	2-4	28	1	1	2:1	10	4
AFS3-02000600-12-ULN	2-6	24	1	1.2	2:1	10	4
AFS3-04000800-10-ULN	4-8	28	1	1	2:1	10	4
AFS3-08001200-14-ULN	8-12	25	1	1.4	2:1	10	4
AFS3-02000800-18-ULN	2-8	24	1.5	1.8	2:1	10	4
AFS4-12001800-28-ULN	12-18	20	1.5	2.8	2:1	10	4
AFS4-08001800-30-ULN	8-18	20	1.75	3	2:1	10	4
AFS4-06001800-35-ULN	6-18	18	2	3.5	2:1	10	4
AFS4-02001800-35-ULN	2-18	22	2.5	3.5	2:1	10	4
AFS3-00100200-15-ULN	0.1-2	36	1	1.5	2:1	10	4
AFS3-00100400-18-ULN	0.1-4	24	1.3	1.8	2:1	10	4
AFS3-00100600-20-ULN	0.1-6	24	1.5	2	2:1	10	4
AFS3-00100800-25-ULN	0.1-8	24	1.5	2.5	2:1	10	4
AFS3-00101000-32-ULN	0.1-10	20	1.5	3.2	2:1	10	4
AFS3-00101200-35-ULN	0.1-12	20	1.75	3.5*	2:1	10	4
AFS4-00101800-40-ULN	0.1-18	22	2.5	4*	2.5:1	10	4
AFS4-00102000-50-ULN	0.1-20	16	2.8	5*	2.5:1	10	4
OCTAVE AND MULTIOCTAVE							
AFS2-00100050-13-LN	0.1-0.5	25	1	1.3	2:1	10	2
AFS2-00500100-12-LN	0.5-0.1	23	1	1.2	2:1	10	2
AFS3-01000200-15-LN	1-2	34	1	1.5	2:1	10	4
AFS3-02000400-13-LN	2-4	28	1	1.3	2:1	10	4
AFS3-02000600-15-LN	2-6	24	1	1.5	2:1	10	4
AFS3-04000800-16-LN	4-8	24	1	1.6	2:1	10	4
AFS3-08001200-22-LN	8-12	22	1	2.2	2:1	10	4
AFS3-02000800-24-LN	2-8	24	1.5	2.4	2:1	10	4
AFS4-12001800-32-LN	12-18	20	1.5	3.2	2:1	10	4
AFS4-08001800-35-LN	8-18	20	1.75	3.5	2:1	10	4
AFS4-06001800-40-LN	6-18	18	2	4	2:1	10	4
AFS3-02001800-50-LN	2-18	20	2.5	5	2:1	10	4
ULTRA-WIDEBAND							
AFS3-00100200-18-LN	0.1-2	36	1	1.8	2:1	10	4
AFS3-00100400-22-LN	0.1-4	24	1.25	2.2	2:1	10	4
AFS3-00100600-25-LN	0.1-6	24	1.5	2.5	2:1	10	4
AFS3-00100800-32-LN	0.1-8	24	1.5	3.2	2:1	10	4
AFS3-00101000-38-LN	0.1-10	22	1.5	3.8	2:1	10	4
AFS3-00101200-42-LN	0.1-12	22	1.75	4.2*	2:1	10	4
AFS4-00101800-55-LN	0.1-18	20	2.5	5.5*	2.5:1	10	4
AFS4-00102000-60-LN	0.1-20	16	2.75	6*	2.5:1	10	4
MEDIUM POWER							
AFS2-00500400-20P-MP	0.5-4	24	1.5	4	2:1/2.5:1	20	4
AFS3-00100600-20P-MP	0.1-6	24	1.5	4.6	2:1	20 [†]	4
AFS4-00100800-20P-MP	0.1-8	24	2	4.8	2:1	20 [†]	4
AFS4-00101200-20P-MP	0.1-12	26	2	5.3*	2:1	20 [†]	4
AFS3-04000800-20P-MP	4-8	25	1.25	3.8	2:1	20	4
AFS4-08001200-20P-MP	8-12	20	1	4.8	2:1	20	4
AFS4-02000800-20P-MP	2-8	24	1.5	5.8	2:1	20	4

* Noise figure increases below 500 MHz.
[†] Above 500 MHz.

LOW NOISE AND MEDIUM POWER AFD AMPLIFIERS

MODEL NUMBER	FREQUENCY RANGE (GHz)	GAIN (dB, Min.)	GAIN VARIATION (\pm dB, Max.)	NOISE FIGURE (dB, Max.)	VSWR IN/OUT (Max.)	OUTPUT POWER @ 1 dB COMP. (dBm, Min.)
MODERATE BAND						
AFD3-012014-09-LN	1.2–1.4	34	0.25	0.9	1.5:1	15
AFD3-022023-10-LN	2.2–2.3	30	0.5	1	1.5:1	10
AFD3-023027-10-LN	2.3–2.7	30	0.5	1	1.5:1	10
AFD3-027031-10-LN	2.7–3.1	30	0.5	1	1.5:1	10
AFD3-031035-10-LN	3.1–3.5	30	0.5	1	1.5:1	10
AFD3-037042-10-LN	3.7–4.2	30	0.5	1	1.5:1	10
OCTAVE AND MULTIOCTAVE						
AFD2-005010-12-LN	0.5–1	20	1	1.2	2:1	10
AFD3-005010-12-LN	0.5–1	32	1	1.2	2:1	10
AFD2-010020-12-LN	1–2	22	1	1.2	2:1	10
AFD3-010020-12-LN	1–2	32	1	1.2	2:1	10
AFD3-010020-10-LN	1–2	32	1	1	2:1	10
AFD3-020040-13-LN	2–4	30	1	1.3	2:1	10
AFD3-040080-28-LN	4–8	25	1	2.8	2:1	10
AFD3-080120-42-LN	8–12	20	1	4.2	2:1	10
AFD2-004014-12-LN	0.4–1.4	25	1	1.2	2:1	10
AFD3-005020-14-LN	0.5–2	34	1	1.4	2:1	10
AFD3-020080-33-LN	2–8	24	1.5	3.3	2:1	10
AFD3-040120-47-LN	4–12	19	1.5	4.7	2:1	10
MEDIUM POWER						
AFD3-027031-25P-MP	2.7–3.1	22	1	4.5	2:1	25
AFD3-031042-25P-MP	3.1–4.2	22	1	4.5	2:1	25
AFD3-040080-25P-MP	4–8	20	1	5	2:1	25
AFD3-080120-23P-MP	8–12	16	1.25	6	2:1	23
AFD3-010040-23P-MP	1–4	22	1.5	5.5	2:1	23
AFD3-020080-23P-MP	2–8	19	1.5	5.5	2:1	23
AFD3-040120-20P-MP	4–12	15	1.5	6	2:1	20

NOTE: Please contact factory for exact outline dimensions.

TEMPERATURE COMPENSATED AMPLIFIERS

AFS SERIES

In any solid state amplifier, both the gain and the noise figure will vary as a function of temperature. The overall gain of an uncompensated amplifier tends to decrease as the base plate temperature increases, while the noise figure will exhibit the opposite effect and increase as the temperature rises. The amount of change in gain is directly proportional to the number of stages in the device, the operating frequency, and the way the individual stages have been biased. In order to reduce this variation, it is often necessary to temperature compensate the amplifier.

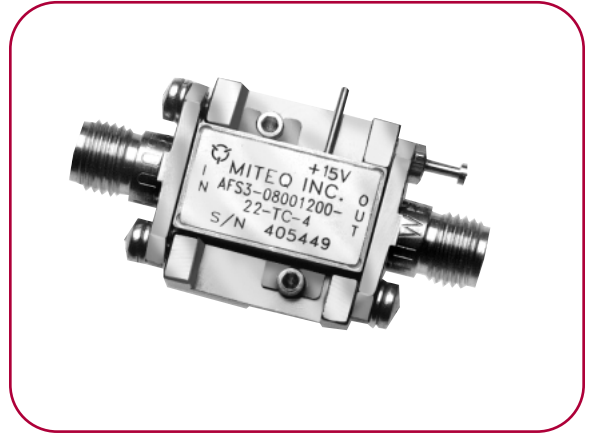

AFS4-02001800-45-TC-5 TYPICAL DATA

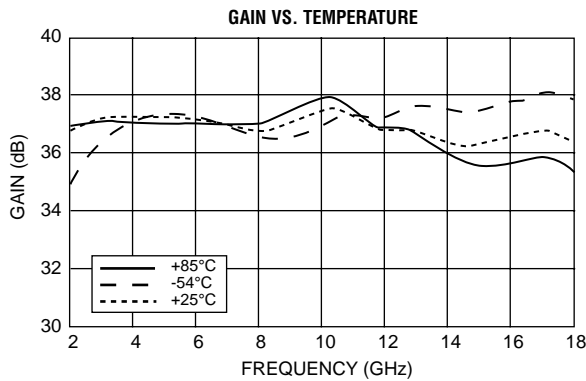

MODEL NUMBER	FREQUENCY RANGE (GHz)	GAIN WINDOW (dB)	GAIN FLATNESS (±dB, Max.)	NOISE FIGURE (dB, Max.)	VSWR IN/OUT (Max.)	OUTPUT POWER @ 1 dB COMP. (dBm, Min.)	NOM. DC POWER (15 V, mA)	OUTLINE DRAWING
AFS2-01000200-15-TC-6	1-2	25-29	1	1.5	2:1	5	125	6
AFS3-01000200-15-TC-6	1-2	36-40	1	1.5	2:1	5	125	6
AFS2-02000400-15-TC-6	2-4	22-26	1	1.5	2:1	5	125	6
AFS3-02000400-15-TC-6	2-4	26-30	1	1.5	2:1	5	125	6
AFS2-04000800-20-TC-2	4-8	17-22	1	2	2:1	5	70	2
AFS3-04000800-18-TC-4	4-8	25-30	1	1.8	2:1	8	100	4
AFS2-02000800-40-TC-2	2-8	14-19	1.5	4	2:1	5	70	2
AFS3-02000800-30-TC-4	2-8	22-27	1.5	3	2:1	8	150	4
AFS4-02000800-26-TC-4	2-8	30-36	1.5	2.6	2:1	8	120	4
AFS2-08001200-30-TC-2	8-12	12-16	1	3	2:1	5	70	2
AFS3-08001200-22-TC-4	8-12	24-28	1	2.2	2:1	8	100	4
AFS4-08001200-20-TC-4	8-12	30-34	1	2	2:1	8	150	4
AFS4-12001800-30-TC-8	12-18	22-26	1	3	2:1	8	250	8
AFS6-12001800-30-TC-8	12-18	28-32	1	3	2:1	8	400	8
AFS4-08001800-35-TC-8	8-18	22-26	1	3.5	2:1	8	250	8
AFS6-08001800-35-TC-8	8-18	30-34	1	3.5	2:1	8	400	8
AFS4-06001800-35-TC-8	6-18	22-26	1	3.5	2:1	8	250	8
AFS6-06001800-35-TC-8	6-18	30-34	1	3.5	2:1	8	400	8
AFS4-02001800-45-TC-5	2-18	18-24	1.5	4.5	2.2:1	8	120	5
AFS5-02001800-45-TC-6	2-18	22-28	1.5	4.5	2.2:1	8	175	6

NOTES: All specifications guaranteed -54 to +85°C.

Please contact the factory for other frequencies, noise figures, and gain options. See page 59 for outline.

CRYOGENIC AMPLIFIERS

AFS SERIES

In addition to our standard low-noise amplifiers, MITEQ can support your needs for amplifiers that operate in cryogenic environments. MITEQ has supplied units cooled to liquid nitrogen temperatures (77 K), as well as units operating at helium (4 K) temperatures. These units utilize our extremely low-noise amplifier designs, which are packaged in hermetically sealed kovar housings.

Due to the fact that silicon-based products do not work well under cryogenic conditions, we have removed the internal voltage regulator and reverse protect diode. As such, the amplifiers can operate at much lower voltages, thus significantly reducing the total power dissipated by the devices within the amplifier.

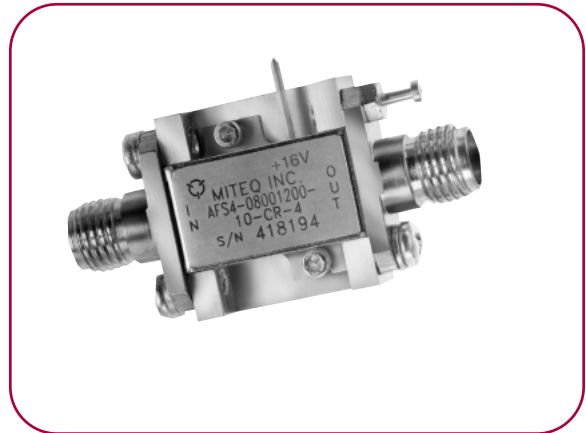

AFS3-00100200-09-CR-4 TYPICAL DATA

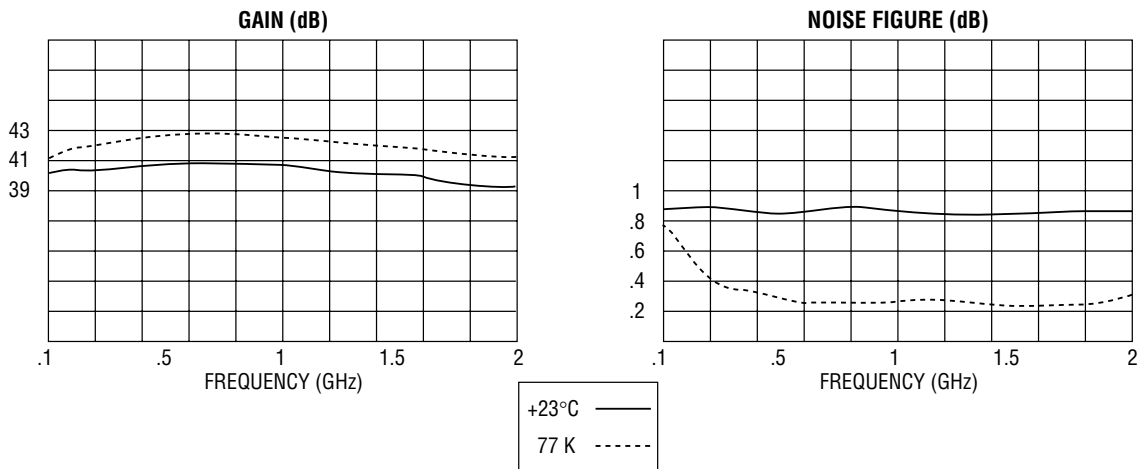

MODEL NUMBER	FREQUENCY RANGE (GHz)	GAIN (dB, Min.)	GAIN FLATNESS (±dB, Max.)	NOISE FIGURE (dB, Max.)	VSWR IN/OUT (Max.)	OUTPUT POWER @ 1 dB COMP. (dBm, Min.)	NOM. DC POWER (+6 V, mA)	OUTLINE DRAWING
AFS3-00100200-09-CR-4 (Nominal specs. @ 77 K)	0.1–2 0.1–2	38 42	1 0.75	0.9 0.25	2:1 1.5:1/1.8:1	5 5	100 100	4 4
AFS3-01000200-06-CR-6 (Nominal specs. @ 77 K)	1–2 1–2	38 40	1 1	0.6 0.20	2:1 1.8:1	5 5	100 100	6 6
AFS3-02000400-08-CR-4 (Nominal specs. @ 77 K)	2–4 2–4	28 33	1 0.5	0.8 0.25	2:1 1.8:1/1.5:1	5 5	75 75	4 4
AFS3-04000800-09-CR-4 (Nominal specs. @ 77 K)	4–8 4–8	31 33	0.5 0.5	0.8 0.2	2:1 1.5:1	5 5	100 100	4 4
AFS4-08001200-10-CR-4 (Nominal specs. @ 77 K)	8–12 8–12	32 34	1 0.75	0.9 0.35	2:1 1.5:1	5 5	100 100	4 4
AFS4-12001800-16-CR-4 (Nominal specs. @ 77 K)	12–18 12–18	30 35	1.5 1.5	1.8 1.3	2:1 2:1	5 10	75 75	4 4

NOTES: The above specifications listed at 77 K were taken on several typical amplifiers. Please contact the factory for actual temperature data. Lower gain and other bands also available. See page 59 for outline.

LOW CURRENT CONSUMPTION AMPLIFIERS

AFS SERIES

FEATURES

- Low voltage operation at 6 V for battery-driven applications
- Small size for tight packaging requirements
- AFS noise figure performance

OPTIONS

- Operation to 4 V is available
- Customized gain, noise figure, etc.
- Temperature compensated designs
- Alternative packages and military screening

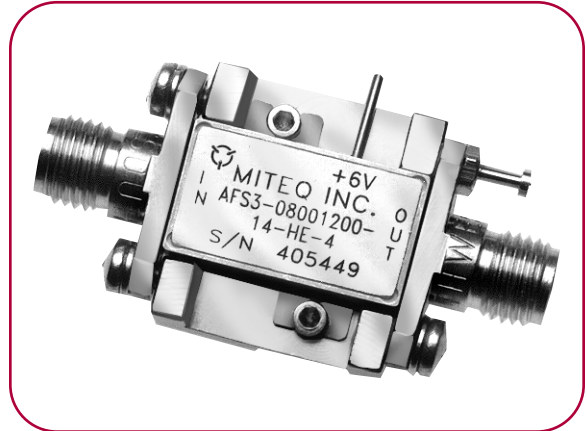

MODEL NUMBER	FREQUENCY RANGE (GHz)	GAIN (dB, Min.)	GAIN FLATNESS (±dB, Max.)	NOISE FIGURE (dB, Max.)	VSWR IN/OUT (Max.)	OUTPUT POWER @ 1 dB COMP. (dBm, Min.)	NOM. DC POWER (6 V, mA)	OUTLINE DRAWING
AFS2-01000200-07-HE-6	1–2	27	1	0.7	2:1	0	25	6
AFS3-01000200-07-HE-6	1–2	38	1	0.7	2:1	0	40	6
AFS2-02000400-08-HE-4	2–4	22	1	0.8	2:1	0	25	4
AFS3-02000400-08-HE-4	2–4	34	1	0.8	2:1	0	40	4
AFS2-04000800-11-HE-2	4–8	20	1	1.1	2:1	0	30	2
AFS3-04000800-10-HE-4	4–8	30	1	1	2:1	0	50	4
AFS3-08001200-14-HE-4	8–12	20	1	1.4	2:1	0	30	4
AFS4-08001200-12-HE-4	8–12	30	1	1.2	2:1	0	50	4
AFS3-12001800-20-HE-4	12–18	15	1.5	2	2:1	0	25	4
AFS4-12001800-20-HE-4	12–18	28	1.5	2	2:1	0	40	4
AFS3-06001800-25-HE-4	6–18	14	2	2.5	2:1	0	25	4
AFS4-06001800-25-HE-4	6–18	26	2	2.5	2:1	0	40	4

NOTES: These units are unregulated and operate off a 6 V supply.
 Optimized frequency ranges, gains, and supply voltages are available.
 See page 59 for outline.

LOW-NOISE HIGH INTERCEPT AMPLIFIERS

AFS SERIES

FEATURES

- Ultra low-noise PHEMT input stages
- Optimized bands from 800 to 930 MHz
- Noise figures from 0.8 dB
- 38 dBm intercept point
- Higher frequency ranges available
- Cellular telephony applications

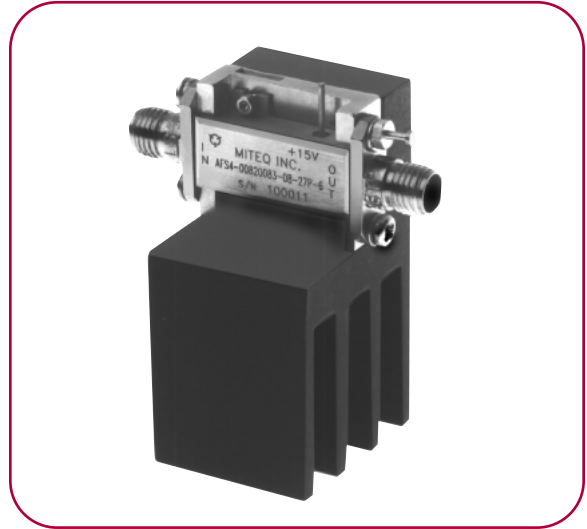

AFS4-00100200-27P-CT-6 TYPICAL DATA

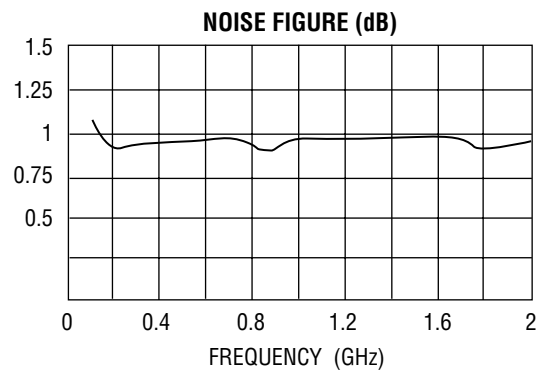
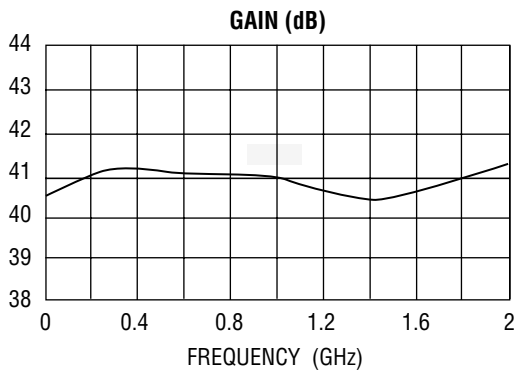

MODEL NUMBER	FREQUENCY RANGE (GHz)	GAIN (dB, Min.)	GAIN FLATNESS (\pm dB, Max.)	NOISE FIGURE (dB, Max.)	VSWR IN/OUT (Max.)	OUTPUT POWER @ 1 dB COMP. (dB, Min.)	OUTPUT IP ³ (dBm, Typ.)	OUTLINE DRAWING
AFS3-00500200-27P-CT-6	0.5–2	33	0.75	2	2:1/2.5:1	27	38	6
AFS4-00500200-27P-CT-6	0.5–2	40	0.75	1	2:1/2.5:1	27	38	6
AFS3-00820086-27P-CT-6	0.82–0.86	31	0.25	0.8	1.5:1/2:1	27	38	6
AFS3-00880093-27P-CT-6	0.88–0.93	31	0.25	0.8	2:1/2:1	27	38	6
AFS4-00820086-27P-CT-6	0.82–0.86	42	0.25	0.8	2:1/2:1	27	38	6
AFS4-00880093-27P-CT-6	0.88–0.93	42	0.25	0.8	2:1/2:1	27	38	6

NOTES: Contact factory for other frequency bands.
See page 60 for outline.

LIMITING AMPLIFIERS

AFD SERIES

Octave and multioctave limiting amplifiers are widely used in instantaneous frequency measurement receivers. Three of the most important performance requirements of limiting amplifiers are:

- To minimize output power variations and provide a constant output over a wide input dynamic range.
- To minimize the harmonic output power under limiting conditions.
- High fidelity to pulsed input signals by minimizing overshoot and recovery times.

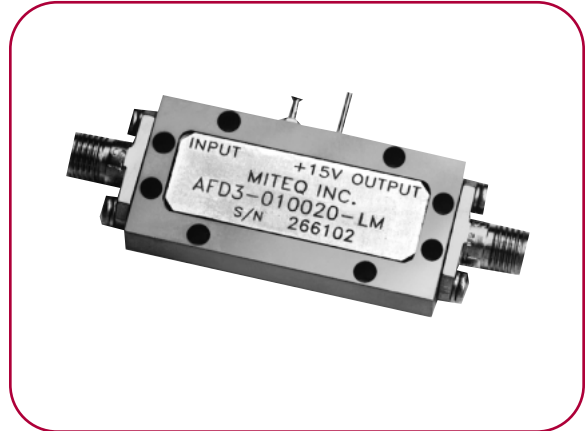

DEFINITION OF LIMITING AMPLIFIER PULSE RESPONSE

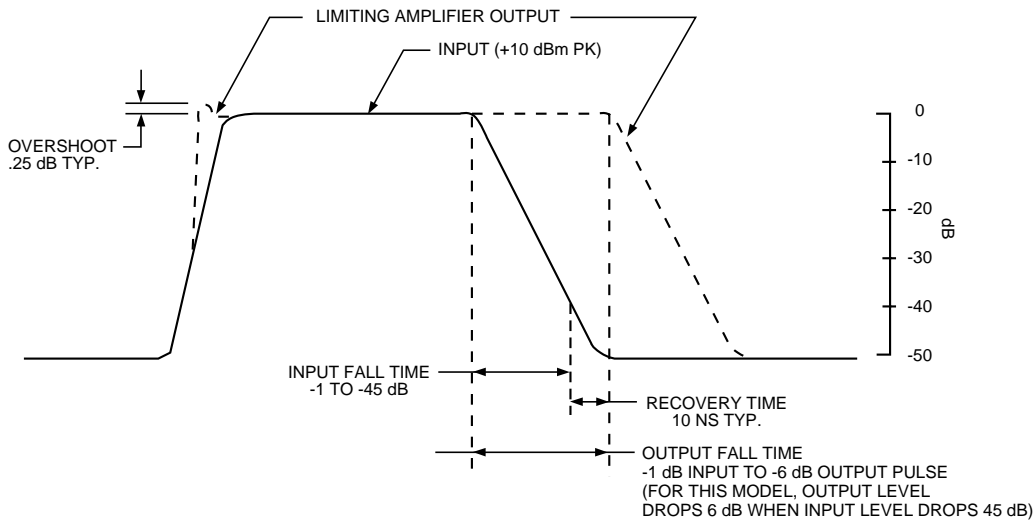

MODEL NUMBER	FREQUENCY RANGE (GHz)	GAIN (dB, Min.)	GAIN FLATNESS (\pm dB, Max.)	NOISE FIGURE (dB, Max.)	POWER RANGE (dBm)		NOM. DC POWER (15V, mA)
					INPUT	OUTPUT	
AFD3-005010-LM	0.5-1	35	1	1.5	-15 - +10	15 - 20	100
AFD3-010020-LM	1-2	35	1	1.5	-15 - +10	15 - 20	100
AFD4-020040-LM	2-4	35	2	3.5	-15 - +10	15 - 20	200
AFD4-020060-LM	2-6	35	2	4.5	-15 - +10	15 - 20	200
AFD4-020080-LM	2-8	35	2	5	-15 - +10	15 - 20	200
AFD4-040080-LM	4-8	35	2	4.5	-15 - +10	15 - 20	200
AFD5-080120-LM	8-12	33	2	6	-15 - +10	15 - 20	250
AFD8-080180-LM	8-18	33	2	8	-15 - +10	15 - 20	450
AFD8-120180-LM	12-18	33	2	8	-15 - +10	15 - 20	450

NOTES: Please contact factory for outline.
 See page 60 for typical outline.
 Harmonic output -10 dBc max., typical.
 Input/output VSWR 2:1 typical.
 Higher gain options available.

MEDIUM POWER AMPLIFIERS

AFSD/MPN SERIES

FEATURES

- High dynamic range
- Up to 1 watt output power
- Usable as a TWTA and SSPA driver amplifier
- High second and third intercept points
- Low power consumption
- EMI suppression filter
- One-year warranty
- Custom frequency, gain, and power options available

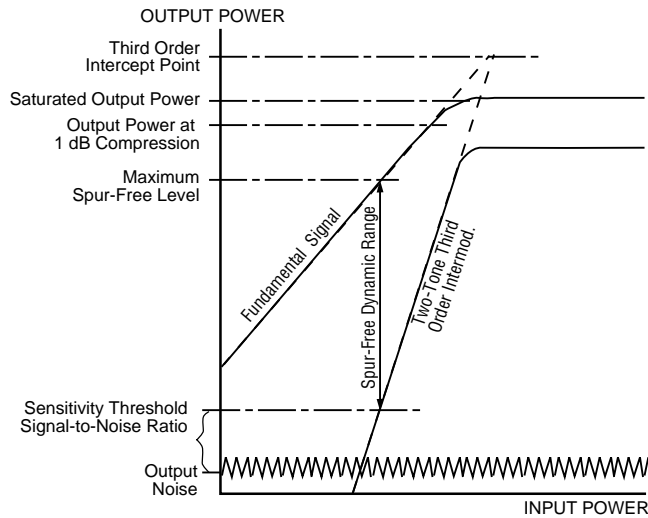
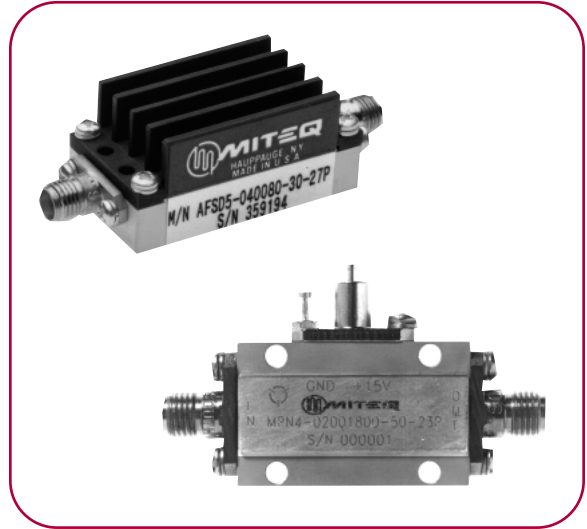

MODEL NUMBER	FREQUENCY RANGE (GHz)	GAIN (dB, Min.)	GAIN FLATNESS (±dB, Max.)	NOISE FIGURE (dB, Max.)	VSWR IN/OUT (Max.)	OUTPUT POWER @ 1 dB COMP. (dBm, Min.)	NOM. DC POWER (15 V, mA)
AFSD5-020080-22-26P	2–8	30	1.2	2.2	2:1	26	550
AFSD4-020060-20-27P	2–6	30	1	2	2:1	27	575
AFSD5-040080-20-27P	4–8	30	1	2	2:1	27	450
AFSD5-040120-35-25P	4–12	25	1.5	3.5	2:1	25	550
AFSD5-060120-30-26P	6–12	26	1	3	2:1	26	575
AFSD5-080100-22-27P	8–10	28	1	2.2	2:1	27	600
AFSD5-080120-25-26P	8–12	28	1	2.5	2:1	26	500
MPN1-00100100-23P*	0.1–1	15	1.5	1.5	2.5:1/2:1	23	200
MPN2-00200200-27P*	0.2–2	23	1.5	2.5	2:1/2.5:1	27	250
MPN2-00500100-30P*	0.5–1	25	1.5	1.5	2:1	30	500
MPN2-01000200-28P*	1–2	27	1.5	1.5	2:1	28	550
MPN3-02000400-25P	2–4	30	1.5	2	2:1	25	300
MPN3-02001800-20P	2–18	20	2.5	5	2.5:1/2.2:1	20	450
MPN4-02001800-23P	2–18	23	2.5	5	2.5:1/2.2:1	23	700

* These models can be optimized for cellular telephony applications.
NOTE: See pages 61 and 62 for outlines.

COAXIAL IN-LINE AMPLIFIERS

AFSX SERIES

FEATURES

- In-line package
- Lower noise figure and customized designs are available

OPTIONS

- Equalized gain
- Matched sets
- “SMA”, “TNC”, or “N” connectors
- Bias through RF output (-BTO)

APPLICATIONS

- Active slope equalizers
- Receiver front ends
- Lossless dividers
- Laboratory use

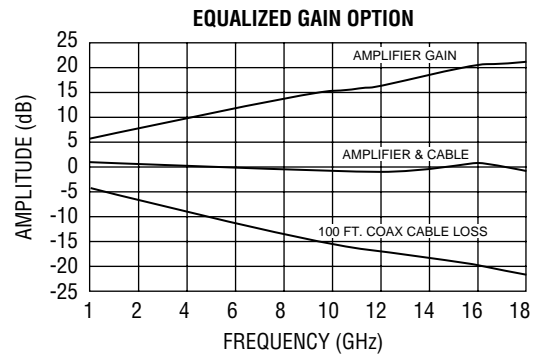
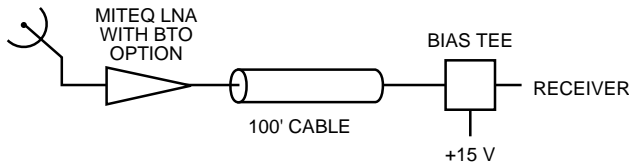
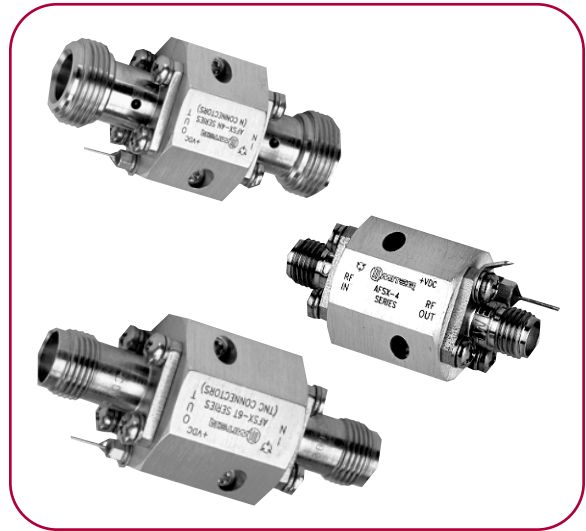

MODEL NUMBER	FREQUENCY RANGE (GHz)	GAIN (dB, Min.)	GAIN FLATNESS (±dB, Max.)	NOISE FIGURE (dB, Max.)	VSWR IN/OUT (Max.)	OUTPUT POWER @ 1 dB COMP. (dBm, Min.)	NOM. DC POWER (+15 V, mA)
AFSX2-00100050-15-8P	0.1–0.5	25	1	1.5	2:1	8	125
AFSX2-00500100-16-10P	0.5–1	24	1	1.6	2:1	10	125
AFSX3-01000200-15-10P	1–2	30	1	1.5	2:1	10	125
AFSX3-02000400-15-10P	2–4	30	1	1.5	2:1	10	125
AFSX4-02000800-24-10P	2–8	20	1.5	2.4	2:1	10	150
AFSX3-04000800-15-10P	4–8	28	1	1.5	2:1	10	125
AFSX3-08001200-28-10P	8–12	26	1	2.8	2:1	10	125
AFSX4-12001800-32-10P	12–18	20	1.5	3.2	2:1	10	125
AFSX4-08001800-35-10P	8–18	20	1.75	3.5	2:1	10	150
AFSX4-06001800-28-8P	6–18	23	2	2.8	2:1	8	150
AFSX4-02001800-50-8P	2–18	20	2.5	5	2:1	8	175
AFSX4-00100100-16-18P	0.1–1	13	1	1.6	2.5:1	18	175
AFSX3-00100200-15-10P	0.1–2	36	1	1.5	2:1	10	150
AFSX3-00100400-22-10P	0.1–4	28	1.25	2.2	2:1	10	150
AFSX4-00100600-46-10P	0.1–6	20	1.5	4.6	2:1	10	175
AFSX4-00100800-48-10P	0.1–8	18	2	4.8	2:1	10	175
AFSX4-00101000-38-10P	0.1–10	20	1.5	3.8	2:1	10	175
AFSX4-00101200-42-10P	0.1–12	20	1.75	4.2	2:1	10	175
AFSX4-00101800-55-10P	0.1–18	18	2.5	5.5	2.5:1	10	175
AFSX4-00102000-60-10P	0.1–20	18	2.75	6	2.5:1	10	175

NOTES: Above specifications are with flat gain.
See page 65 for outline.

SUBSTRATE AMPLIFIERS

AFSB SERIES

FEATURES

- Ideal for gain blocks and drivers
- Ideal building blocks for your own design: low-noise, interstage and output modules
- Available with low and medium power levels
- 25 mil 50 ohm microstrip interface

OPTIONS

- Hermetic sealing
- Lower noise figure and customized designs available

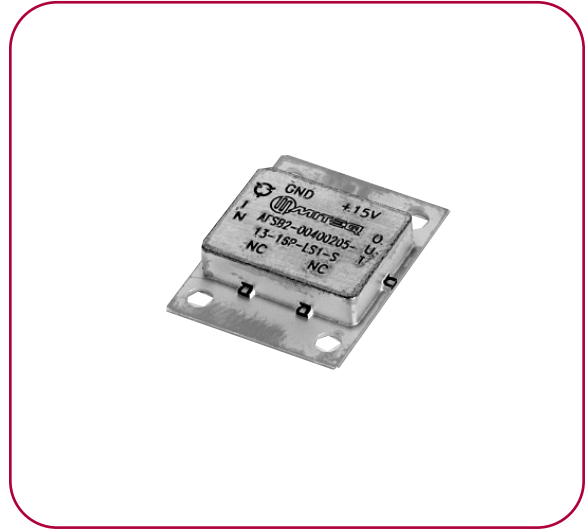

AFSB-00102000-45-10P TYPICAL DATA

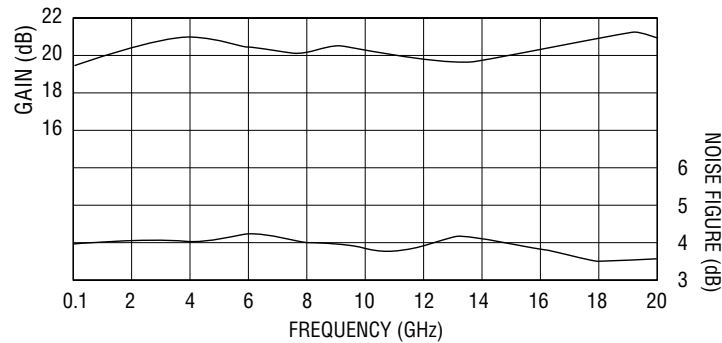

MODEL NUMBER	FREQUENCY RANGE (GHz)	GAIN (dB, Min.)	GAIN FLATNESS (±dB, Max.)	NOISE FIGURE (dB, Max.)	VSWR IN/OUT (Max.)	OUTPUT POWER @ 1 dB COMP. (dBm, Min.)	NOM. DC POWER (+15 V, mA)
OCTAVE AND MULTIOCTAVE							
AFSB-00500100-09-10P	0.5–1	24	1	0.9	2:1	10	125
AFSB-01000200-09-10P	1–2	28	1	0.9	2:1	10	150
AFSB-02000400-15-10P	2–4	30	1	1.5	2:1	10	150
AFSB-02000800-18-10P	2–8	20	1.5	1.8	2:1	10	240
AFSB-12001800-20-10P	12–18	20	1.5	2	2:1	10	240
AFSB-08001800-25-10P	8–18	20	1.75	2.5	2:1	10	240
AFSB-06001800-28-10P	6–18	23	2	2.8	2:1	10	150
AFSB-02001800-30-10P	2–18	20	2.5	3	2:1	10	150
ULTRA-WIDEBAND							
AFSB-00100100-16-18P	0.1–1	13	1	1.6	2.5:1	18	150
AFSB-00100200-15-10P	0.1–2	36	1	1.5	2:1	10	150
AFSB-00100400-20-10P	0.1–4	28	1.25	2	2:1	10	240
AFSB-00100600-20-10P	0.1–6	20	1.5	2	2:1	10	240
AFSB-00100800-25-10P	0.1–8	18	2	2.5	2:1	10	240
AFSB-00101800-45-10P	0.1–18	18	2.5	4.5	2:1	10	240
AFSB-00102000-45-10P	0.1–20	16	2.75	4.5	2.5:1	10	240
MEDIUM POWER							
AFSB-00100600-48-18P	0.1–6	18	2	4.8	2:1	18	375
AFSB-06001800-48-18P	6–18	20	2	4.8	2:1	18	150
AFSB-02001800-70-18P	2–18	20	2.75	7	2:1	18	375

NOTE: See page 66 for outline.

SURFACE MOUNT AMPLIFIERS

AFSM SERIES

FEATURES

- Low noise at competitive prices in a surface mount amplifier
- Reduce assembly costs at the system level
- Substantial size reduction at the system or board level
- Both high and low frequency designs available (0.1–20 GHz)
- High reliability due to:
 - Hermetic sealing
 - High input to output isolation
 - Mechanically rugged internal assembly



TYPICAL DATA

CONNECTORIZED OPTION

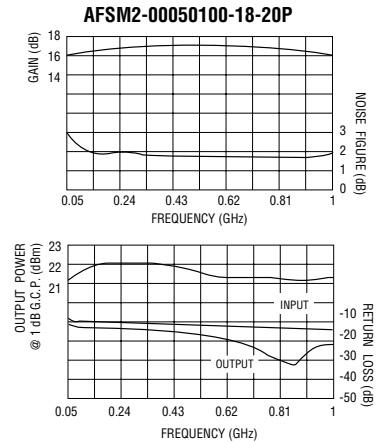
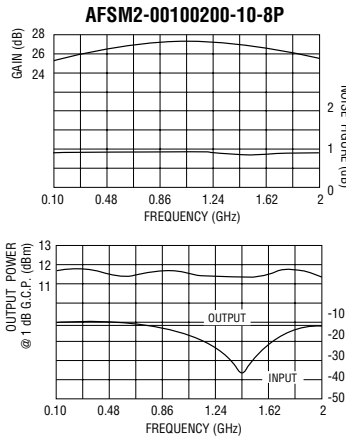
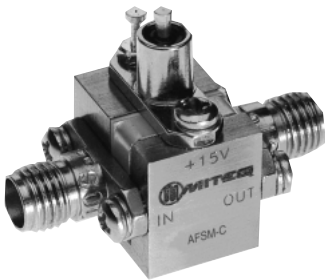

MODEL NUMBER	FREQUENCY RANGE (GHz)	GAIN (dB, Min.)	GAIN VARIATION (±dB, Max.)	NOISE FIGURE (dB, Max.)	VSWR (Max.) IN/OUT	OUTPUT POWER @ 1 dB COMP. (dBm, Min.)	NOM. DC POWER (+15 V, mA)
AFSM2-00100200-12-8P	0.1–2	22	1	1.2	2:1	8	80
AFSM2-00100300-12-8P	0.1–3	20	1	1.2	2:1	8	80
AFSM2-00100400-18-8P	0.1–4	20	1	1.8	2:1	8	80
AFSM2-00100600-18-8P	0.1–6	18	1.5	1.8	2:1	8	80
AFSM2-00500100-08-8P	0.5–1	25	1	0.8	2:1	8	80
AFSM2-01000200-08-8P	1–2	25	1	0.8	2:1	8	80
AFSM2-02000400-10-8P	2–4	21	1	1	2:1	8	80
AFSM2-04000800-20-8P	4–8	20	1	2	2:1	8	100
AFSM2-08001200-15-8P	8–12	20	1	1.5	2:1	8	100
AFSM2-02000600-12-8P	2–6	20	1	1.2	2:1	8	80
AFSM3-12001800-25-8P	12–18	20	1	2.5	2:1	8	125
AFSM3-02001800-40-8P	2–18	18	2.75	4	2.5:1	8	100
AFSM3-00102000-50-8P	0.1–20	16	2.75	5	2.5:1	8	100
AFSM1-00100200-16-16P	0.1–2	12	1	1.6	2:1	16	80
AFSM1-00050100-18-20P	0.05–1	13	1	1.8*	2.5:1/2:1	20	150
AFSM1-01000200-16-20P	1–2	13	1	1.6	2:1	20	150
AFSM2-02002000-70-19P	2–20	12	2.75	7	2.5:1	19	200

* Noise figure increases from .05–0.1 GHz.

NOTES: For connectorized option, add “-C” to part number.
Other frequency bands also available.
See page 63 for outline.

CONNECTORIZED/SURFACE MOUNT AMPLIFIERS

NSM SERIES

FEATURES

- Removable SMA connectors, test fixture, and EMI DC feedthru
- Usable as a true surface mount
- Hermetically sealed housings even for commercial applications
- 0-80 mounting hardware included
- Various bandwidth, gain, noise figure, power and VSWR options available

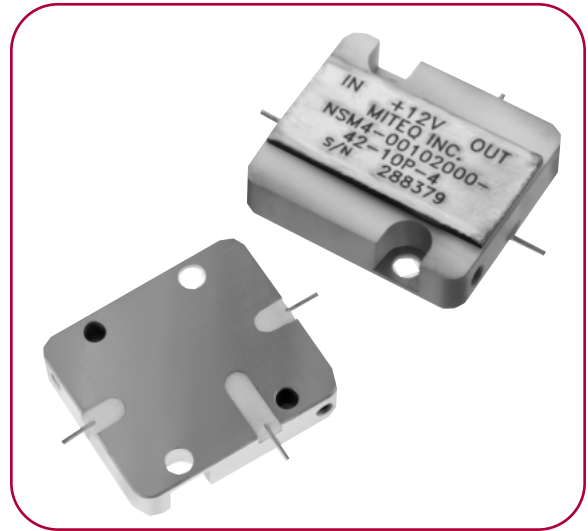

TEST/MOUNTING FIXTURE

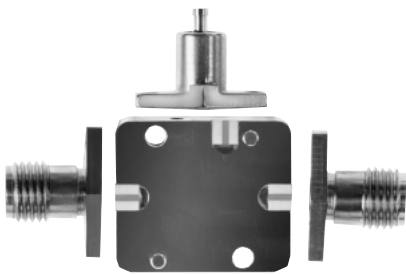

NSM4-00102000-50-8P-4 TYPICAL DATA

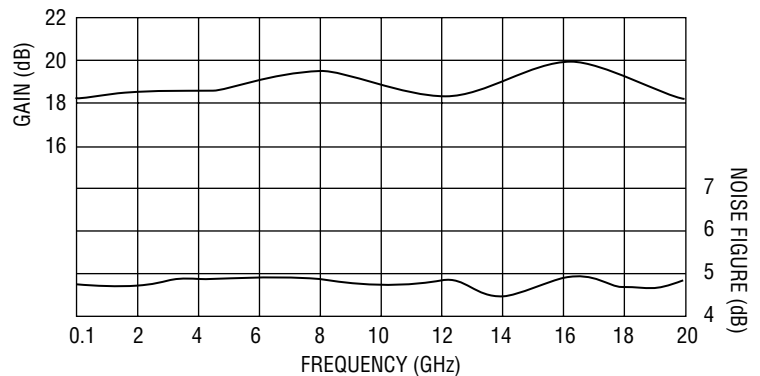

MODEL NUMBER	FREQUENCY RANGE (GHz)	GAIN (dB, Min.)	GAIN FLATNESS (±dB, Max.)	NOISE FIGURE (dB, Max.)	VSWR IN/OUT (Max.)	OUTPUT POWER @ 1 dB COMP. (dBm, Min.)	NOM. DC POWER (+15 V, mA)
NSM3-01000200-10-S-4	1-2	32	1	1	2:1	10	150
NSM3-02000400-12-S-4	2-4	30	1	1.2	2:1	10	150
NSM3-02000600-13-10P-4	2-6	24	1	1.3	2:1	10	100
NSM3-04000800-10-S-4	4-8	24	1	1	2:1	10	100
NSM3-02000800-14-10P-4	2-8	24	1	1.4	2:1	10	100
NSM3-00100200-14-10P-4	0.1-2	30	1	1.4	2:1	10	150
NSM3-00100400-14-10P-4	0.1-4	24	1	1.4	2:1	10	100
NSM3-00100600-15-10P-4	0.1-6	24	1.5	1.5	2:1	10	100
NSM3-00100800-18-10P-4	0.1-8	24	1.5	1.8	2:1	10	100
NSM4-00101000-26-10P-4	0.1-10	24	1.5	2.6	2:1	10	150
NSM4-00101200-28-10P-4	0.1-12	24	1.5	2.8*	2:1	10	150
NSM4-00101800-45-8P-4	0.1-18	22	2.5	4.5*	2.2:1	8	150
NSM4-00102000-50-8P-4	0.1-20	18	2.5	5*	2.5:1	8	175

* Noise figure increases below 500 MHz.
NOTE: See page 64 for outline.

PULSE MODULATED AND POWER GATED AMPLIFIERS

AFSW/AFTL SERIES

FEATURES

PULSE MODULATED

- Modulation rates up to 500 kHz PRF
- Video leakage approximately 250 mV
- Rise time < 50 ns
- Fall time < 250 ns

POWER GATED

- Power can be turned “on” or “off” by applying a TTL signal
- On/off rates up to 10 kHz
- Rise time < 1.2 μ s
- Fall time < 3.5 μ s

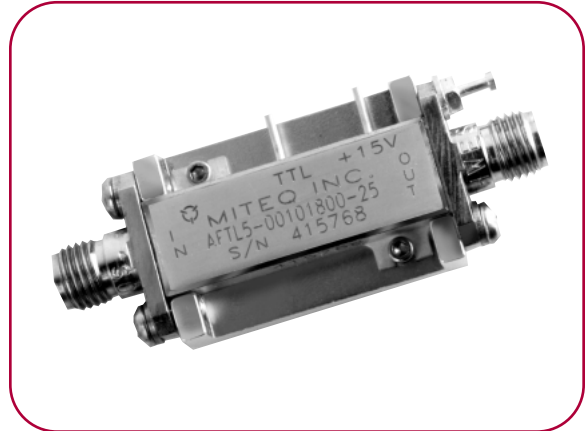

MODEL NUMBER	FREQUENCY RANGE (GHz)	GAIN (dB, Min.)	GAIN FLATNESS (\pm dB, Max.)	NOISE FIGURE (dB, Max.)	VSWR IN/OUT (Max.)	OUTPUT POWER @ 1 dB COMP. (dBm, Min.)	NOM. DC POWER (+15 V, mA)
PULSE MODULATED AMPLIFIERS							
AFSW3-04000800-10	4–8	30	1	1	2:1	10	125
AFSW4-08001200-11	8–12	32	1	1.1	2:1	10	150
AFSW3-02000800-15	2–8	26	1	1.5	2:1	10	125
AFSW3-00100600-16	0.1–6	28	1.2	1.6	2:1	10	125
AFSW3-00100800-20	0.1–8	26	1.2	2	2:1	10	125
AFSW4-00101200-30	0.1–12	26	1.5	3*	2:1	10	150
AFSW5-00101800-35	0.1–18	25	2	3.5*	2.2:1	10	200
POWER GATED AMPLIFIERS							
AFTL3-04000800-09	4–8	30	1	0.9	2:1	10	125
AFTL4-08001200-11	8–12	32	1	1.1	2:1	10	150
AFTL3-02000800-15	2–8	26	1	1.5	2:1	10	125
AFTL3-00100600-16	0.1–6	28	1.25	1.6	2:1	10	125
AFTL3-00100800-20	0.1–8	26	1.25	2	2:1	10	125
AFTL4-00101200-30	0.1–12	26	1.5	3*	2:1	10	150
AFTL5-00101800-35	0.1–18	25	2	3.5*	2.2:1	10	200
AFTL5-00101800-25	0.1–18	25	2.25	2.5*	2:1	10*	200
AFTL4-00102650-40	0.1–26.5	18	2.5	4*	2.5:1	8*	150

* Above 500 MHz.
NOTE: See pages 66 and 68 for outlines.

BLOCK DIAGRAMS

PULSE MODULATED

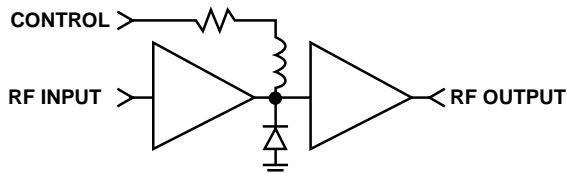

POWER GATED

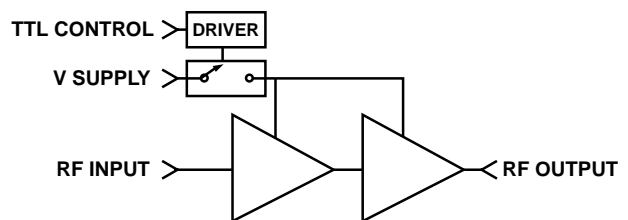

POWER MONITORING AMPLIFIERS

GAIN CONTROL WITH POWER MONITORING SERIES

FEATURES

- 15 dB minimum gain control
- Continuous power monitoring
- Hermetically sealed unit
- Diode detector for sampling the output power
- Removable SMA connectors and test fixture for drop-in use

OPTIONS

- Military screening for high reliability programs
- Instrumentation configuration available
- Custom designs for higher power out is available

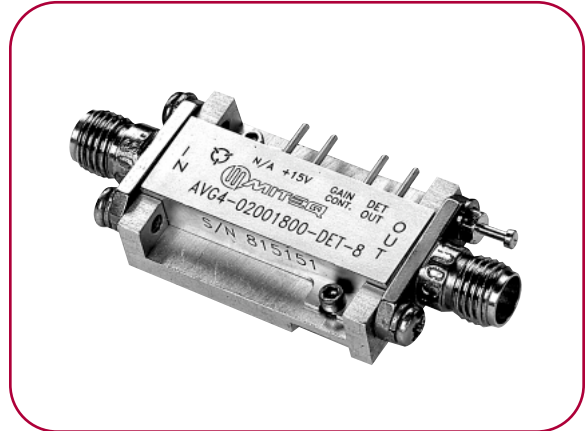

BLOCK DIAGRAM

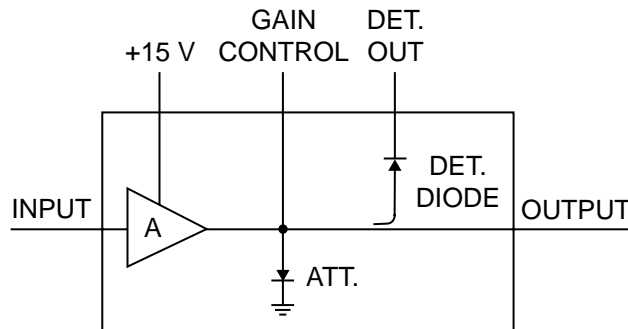

MODEL NUMBER	FREQUENCY RANGE (GHz)	GAIN (dB, Min.)	GAIN FLATNESS (\pm dB, Max.)	NOISE FIGURE (dB, Max.)	VSWR IN/OUT (Max.)	OUTPUT POWER @ 1 dB COMP. (dBm, Min.)	NOM. DC POWER (+15 V, mA)
AVG4-00100800-DET-8	0.1–8	26	1	2.8	2:1	10	175
AVG4-00101200-DET-8	0.1–12	26	1.25	3	2:1	10	185
AVG4-00101800-DET-8	0.1–18	26	2.5	3.5	2.5:1	10	180
AVG4-04000800-DET-8	4–8	32	1	1.8	2:1	10	125
AVG4-08001200-DET-8	8–12	28	1	2	2:1	10	125
AVG4-02000800-DET-8	2–8	28	1	2.5	2:1	10	175
AVG4-02001800-DET-8	2–18	26	2.5	3	2.5:1	10	180

NOTES: The detected output voltage range can be from 0 to 600 mV depending on power output.
 The gain control range is 0 to 15 dB.
 Specifications are with 0 dB of attenuation.
 See page 70 for outline.

VARIABLE GAIN AMPLIFIERS

AVG SERIES

FEATURES

- Gain can be adjusted continuously (0–15 dB) by applying a DC control voltage to the control pin with an external resistor in series (x 470 ohms)
- Covers entire 0.1–20 GHz range
- Ideal for broadband receiver AGC and CFAR circuits
- Various bandwidth, gain, noise figure, and power options are available

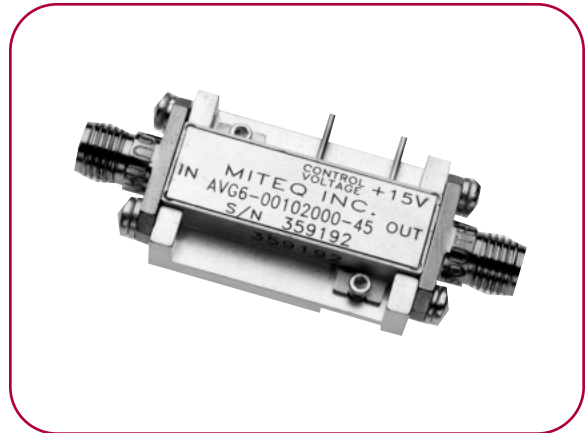

TYPICAL DATA

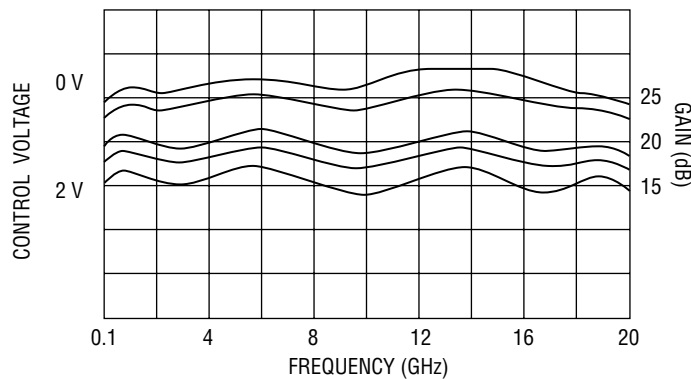

MODEL NUMBER	FREQUENCY RANGE (GHz)	GAIN (dB, Min.)	GAIN FLATNESS (±dB, Max.)	NOISE FIGURE (dB, Max.)	VSWR IN/OUT (Max.)	OUTPUT POWER @ 1 dB COMP. (dBm, Min.)	NOM. DC POWER (+15 V, mA)
AVG4-00100400-14	0.1–4	32	1	1.4*	2:1	10	120
AVG4-00100600-15	0.1–6	32	1	1.5*	2:1	10	120
AVG4-00100800-18	0.1–8	32	1.5	1.8*	2:1	10	120
AVG4-02000800-20	2–8	32	1.25	2	2:1	10	120
AVG6-00102000-45	0.1–20	24	2.5	4.5*	2.5:1	10	250
AVG4-06001200-19	6–12	24	1.5	1.9	2:1	10	175
AVG4-06001800-25	6–18	22	2	2.5	2.3:1	10	185
AVG4-02001800-40	2–18	25	2.25	4	2.5:1	10	180

* Noise figure increases below 500 MHz.
 NOTES: All above specifications at 0 dB attenuation.
 See page 66 for outline.

BUILT-IN TEST DETECTOR AMPLIFIERS

ABIT SERIES

FEATURES

- External threshold control via voltage divider or external power supply
- Independent TTL output
- Up to 1/2 watt CW power output
- Hermetically sealed Kovar chassis capable of meeting rigorous military environments
- Available with various other electrical parameters, alternate connectors, and detect output only (no RF)

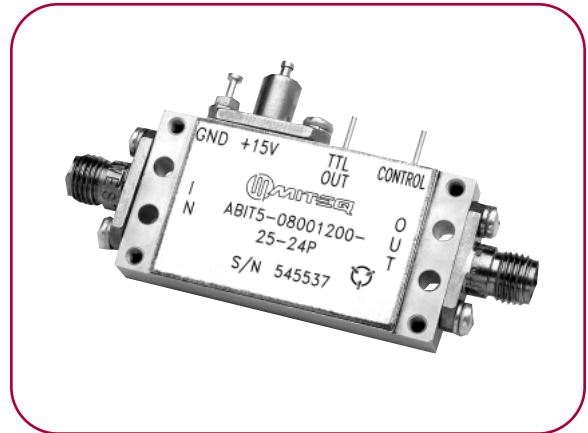

SPECIFICATIONS

Model Number	ABIT5-08001200-25-24P	ABIT5-04000800-25-25P
Frequency range	8–12 GHz	4–8 GHz
Gain	30 dB minimum	30 dB minimum
Noise figure	2.5 dB maximum	2.5 dB maximum
1 dB gain compression	24 dBm minimum	25 dBm minimum
BIT detector threshold	< 20 dBm*	< 20 dBm*
BIT detection format	TTL single ended	TTL single ended
Output power	Logic 1 = +3.7 ±1.3 VDC Logic 1 = +0.4 ±0.4 VDC	Logic 1 = +3.7 ±1.3 VDC Logic 1 = +0.4 ±0.4 VDC

* Other levels available via adjustment to the threshold control.

NOTE: See page 68 for outline.

BLOCK DIAGRAM

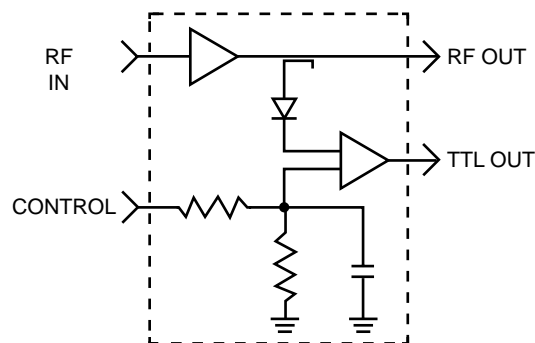

DUAL OUTPUT AMPLIFIERS

AFPD SERIES

FEATURES

- Useful for bench and lab use
- 30 dB typical output port-to-port isolation
- Optional gain and phase tracking between output ports
- Three output port option

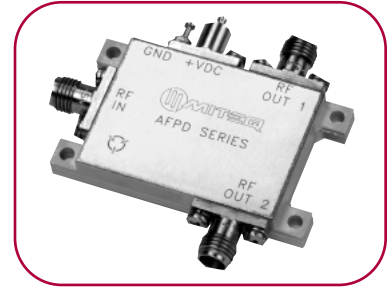
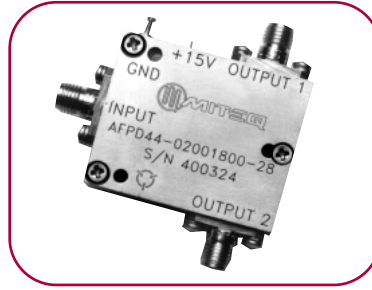

AFPD44-00102000-50 TYPICAL DATA

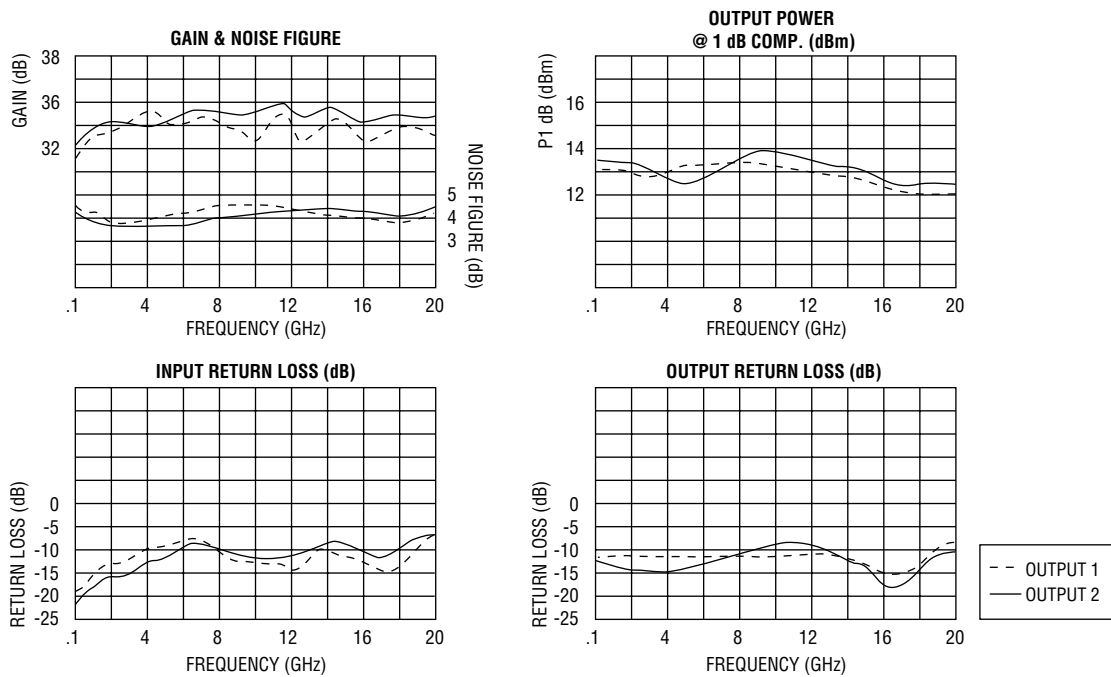

NOTE: Above data is for both output ports.

MODEL NUMBER	FREQUENCY RANGE (GHz)	GAIN (dB, Min.)	GAIN FLATNESS (±dB, Max.)	NOISE FIGURE (dB, Max.)	VSWR IN/OUT (Max.)	OUTPUT POWER @ 1 dB COMP. (dBm, Min.)	NOM. DC POWER (+15 V, mA)
AFPD44-00500200-20	0.5–2	35	2	2	2:1	10	350
AFPD44-00500200-20P	0.5–2	35	2	4	2:1	20	650
AFPD44-00100400-20P	0.1–4	30	2	4	2:1	20	450
AFPD44-00101200-30	0.1–12	32	2	3	2:1	10	375
AFPD44-00101200-20P	0.1–12	30	2.5	6	2:1	20	500
AFPD44-02001800-20P**	2–18	35	3	8	2.5:1	20	600
AFPD44-00102000-50**	0.1–20	32	3	5*	2.5:1	10	400
AFPD44-00102000-20P**	0.5–20	26	3	6*	2.5:1	20	650

* Noise figure increases below 500 MHz.

** Available in hermetic package.

NOTE: See page 67 for outlines.

DESKTOP PREAMPLIFIERS

NEW IMPROVED NSP SERIES

FEATURES

- Broadband frequency 0.1–40 GHz
- Fixed gain or variable up to 15 dB
- Built-in CE approved power supply
- SMA input/output connectors

OPTIONS

- Dual output, input limiter, DC block and temperature compensation
- Various combinations of frequency, bandwidth, gain, noise figure, power and VSWR
- Other connector types available



MODEL NUMBER	FREQUENCY RANGE (GHz)	GAIN (dB, Min.)	GAIN FLATNESS (±dB, Max.)	* NOISE FIGURE (dB, Max.)	VSWR IN/OUT	* OUTPUT POWER @ 1 dB COMP. (dBm, Min.)
LOW-NOISE, VARIABLE GAIN AMPLIFIERS						
NSP1000-NVG	0.1–10	35	2	2.3	2:1	10
NSP1200-NVG	0.1–12	32	2	2.5	2:1	10
NSP1800-NVG	0.3–18	30	2.5	4	2.5:1	10
NSP2200-NVG	0.3–22	30	2.75	4.5	2.5:1	8
MEDIUM POWER, VARIABLE GAIN AMPLIFIERS						
NSP1000-PVG	0.1–10	35	2	5	2:1	20
NSP1200-PVG	0.1–12	32	2.5	5.5	2:1	20
NSP1800-PVG	0.3–18	30	2.75	6.5	2.5:1	20
NSP2000-PVG	0.3–20	30	3	7	2:1	20
LOW-NOISE, FIXED GAIN AMPLIFIERS						
NSP1000-NFG	0.1–10	28	2	2.3	2:1	10
NSP1200-NFG	0.1–12	28	2	2.5	2:1	10
NSP1800-NFG	0.3–18	20	2.5	3.5	2.5:1	10
NSP2650-NFG	0.3–26.5	22	2.75	4.5	2.5:1	8
NSP4000-NFG	0.3–40**	22	3	5	2.5:1	8
MEDIUM POWER, FIXED GAIN AMPLIFIERS						
NSP1000-PFG	0.1–10	25	2	5	2:1	20
NSP1200-PFG	0.1–12	25	2.25	5.5	2:1	20
NSP1800-PFG	0.3–18	18	2.75	8	2.5:1	20
NSP2000-PFG	0.3–20	18	3	8	2.5:1	20
NSP2200-PFG	0.3–22	18	3	8	2.5:1	20

* Specification applies above 500 MHz.

** Split into 2 separate bands (0.1–26.5 GHz and 26.5–40 GHz).

NOTES: Noise figure, VSWR, and output power are specified at maximum gain for variable gain amplifiers.
Power supply 110/220 V selectable, 40–60 Hz.
See page 64 for outline.

40 GHz BIAS TEE AND DC BLOCK

FEATURES

- Ultra broadband performance
- Low insertion loss
- Off-the-shelf delivery
- Compact design
- Suitable for 40 Gb systems
- OC768 transmitters and receivers
- General purpose test and measurement systems

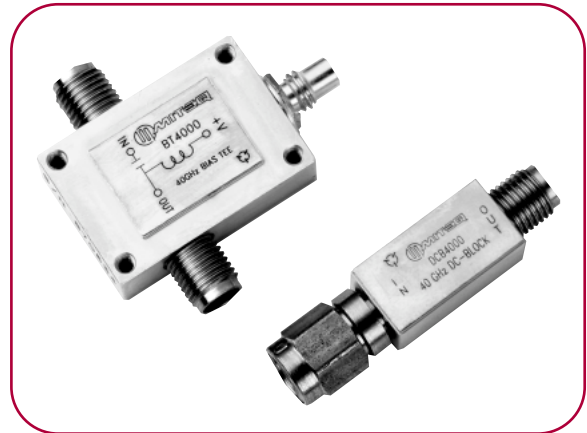

OPTIONS

- Custom frequency bandwidths
- Different connector outputs

SPECIFICATIONS

Model Number	BT4000	DCB4000
Type	Bias Tee	DC Block
Frequency	30 kHz–40 GHz	30 kHz–40 GHz
Insertion loss	< 1.5 dB	< 1.3 dB
VSWR (in/out)	< 2:1	< 2:1
DC current	150 mA maximum	—
DC voltage	< +25 V maximum	< +25 V maximum

NOTE: See page 69 for outlines.

TYPICAL DATA

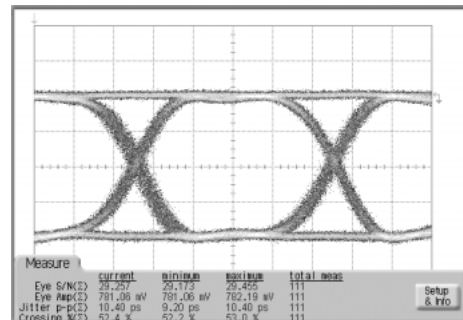
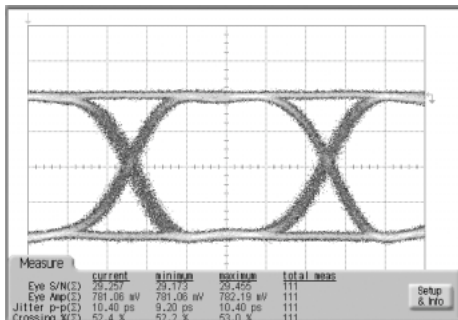
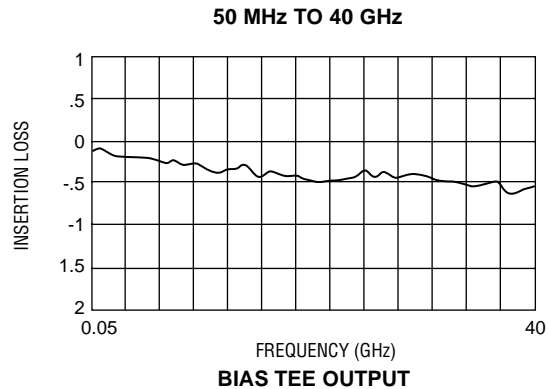
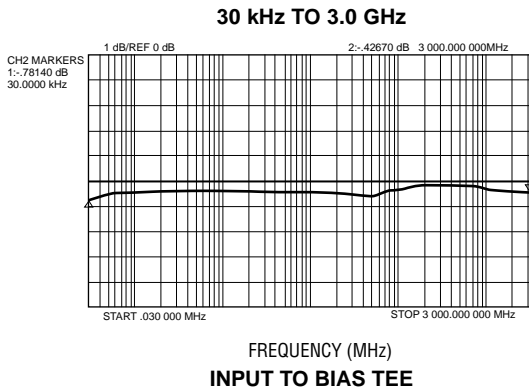

LOW FREQUENCY BIAS TEE CHASSIS

FEATURES

- Frequency range up to 20 GHz
- Low cost
- Connectorized or drop-in style
- Hermetically sealed Kovar chassis

OPTION

- Other frequency bandwidths are also available

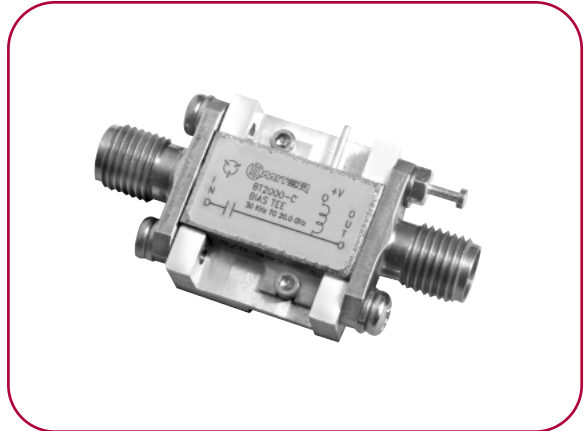

MODEL NUMBER	PACKAGE TYPE	FREQUENCY RANGE	INSERTION LOSS (\leq dB)	VSWR IN/OUT	CURRENT (\leq mA, Max.)
BT0200-C	AFS-4	30 kHz – 2 GHz	0.5	\leq 1.5:1	250
BT0400-C	AFS-4	30 kHz – 4 GHz	0.6	\leq 1.5:1	250
BT0600-C	AFS-4	30 kHz – 6 GHz	0.7	\leq 1.5:1	250
BT0800-C	AFS-4	30 kHz – 8 GHz	0.8	\leq 1.8:1	250
BT1200-C	AFS-4	30 kHz – 12 GHz	1	\leq 1.8:1	250
BT1800-C	AFS-4	30 kHz – 18 GHz	1.2	\leq 2:1	250
BT2000-C	AFS-4	30 kHz – 20 GHz	1.4	\leq 2:1	250

NOTE: See page 70 for outline.

POWER SUPPLY

PS SERIES

FEATURES

- Fully isolated outputs
- Overvoltage and overcurrent protection
- High efficiency
- Short circuit protected



SPECIFICATIONS

Model Number	PS15V	PS12V
Input, VAC	117 ±10%, 50/60 Hz	117 ±10%, 50/60 Hz
Output	15 V @ 900 mA	12 V @ 1000 mA
Ripple, MV p-p	50	50
Regulation, 5%	15 V	12 V
Efficiency	> 75%	> 75%
Operating temperature	0 to 50°C	0 to 50°C
Storage temperature	-55 to +85°C	-55 to +85°C

NOTE: See page 68 for outline.

GENERAL AMPLIFIER OPTIONS

Options for a variety of special performance and testing requirements as well as connector types can be identified by adding a suffix to the part number. The table below lists the most commonly requested options. Option requests should be accompanied by a description of the required performance detailed, as applicable.

STANDARD PERFORMANCE OPTIONS	SUFFIX	STANDARD CONNECTOR OPTIONS	SUFFIX
Input Limiter	-L	K Type Connector	-K
Gain Window	-GW	N Type Connector	-N
Temperature Compensation	-TC	TNC Type Connector	-T
Phase Match	-PM	SMA Male	-M
Amplitude Match	-AM		
Amplitude/Phase Match	-APM		
Gain Control	-GC		
Kovar Chassis	-KC		
Bias Through Output	-BTO		
Bias Through Input	-BTI		
Gain Slope	-GS		
Phase and Gain Tracking	-PG		
Combination of three or more standard options	-S		

NOTE: When specifying these options, please include applicable detailed information.

OUTLINE DRAWINGS

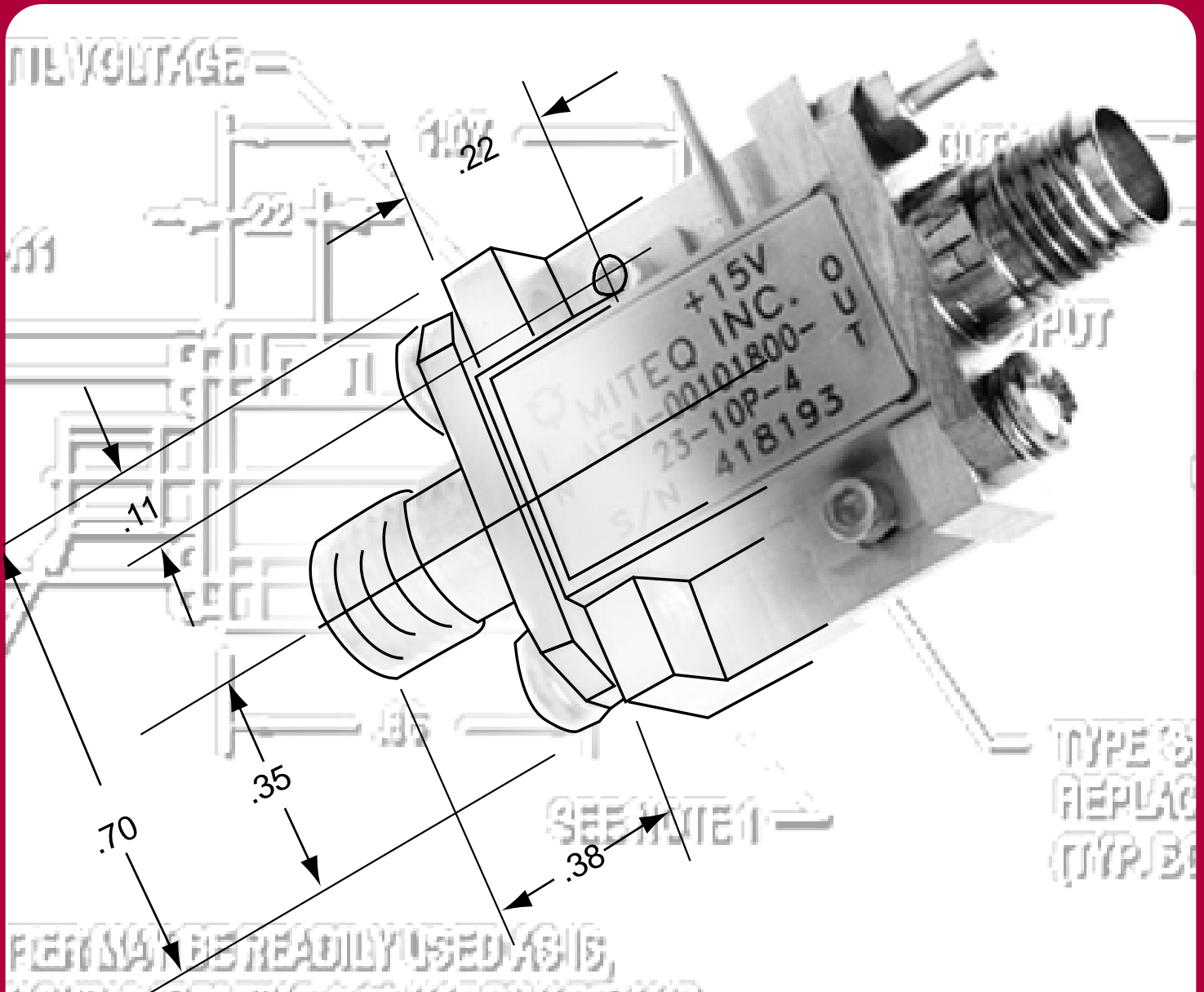

OUTLINE NOTES

1. Dimensions are all in inches.
2. Unless specified, all connectors are type SMA female field replaceable connectors.
3. Tolerances are as follows:
.XX = $\pm .01$
.XXX = $\pm .005$
4. On most models, the amplifiers may be readily used as is, by removing existing 0-80 hardware and substituting longer 0-80 screws for customer mounting.

OUTLINE DRAWINGS

AFS SERIES

OUTLINE DRAWINGS 2 THROUGH 8

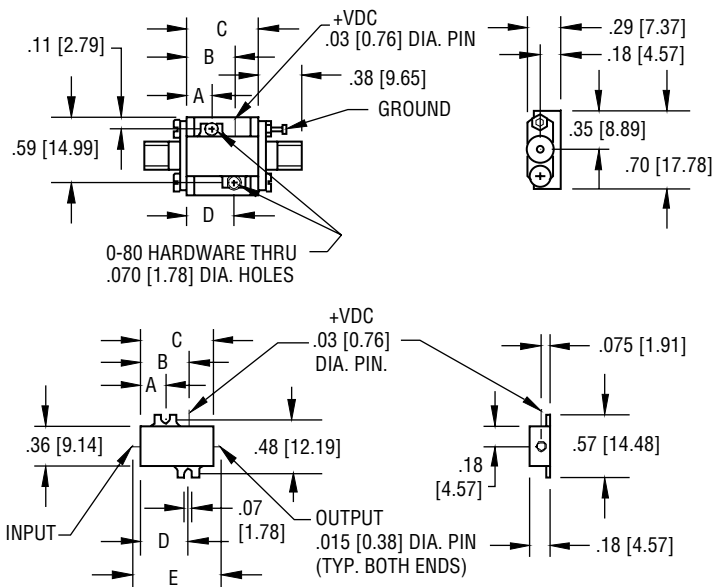

THIS AMPLIFIER CAN ALSO BE USED AS A "DROP-IN" BY REMOVING SMA CONNECTORS AND MOUNTING HARDWARE AS SHOWN

DASH NO.	DIM A	DIM B	DIM C	DIM D	DIM E
-2	.16 [4.06]	.28 [7.11]	.43 [10.92]	.27 [6.86]	.58 [14.73]
-3	.16 [4.06]	.32 [8.13]	.53 [13.46]	.38 [9.65]	.69 [17.53]
-4	.22 [5.59]	.43 [10.92]	.64 [16.26]	.42 [10.67]	.80 [20.32]
-5	.22 [5.59]	.53 [13.46]	.75 [19.05]	.53 [13.46]	.91 [23.11]
-6	.22 [5.59]	.64 [16.26]	.86 [21.84]	.64 [16.26]	1.01 [25.65]
-7	.22 [5.59]	.75 [19.05]	.97 [24.64]	.75 [19.05]	1.11 [28.19]
-8	.22 [5.59]	.86 [21.84]	1.07 [27.18]	.86 [21.84]	1.21 [30.73]

OUTLINE 42

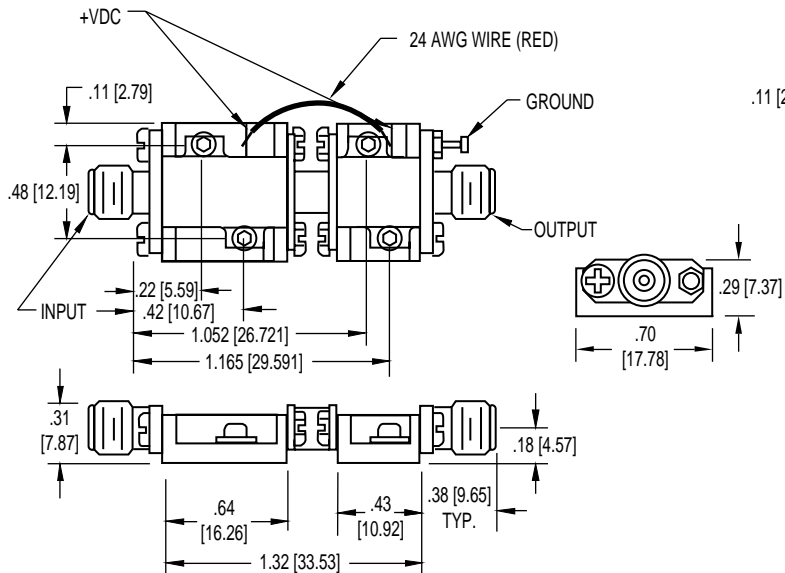

OUTLINE 44

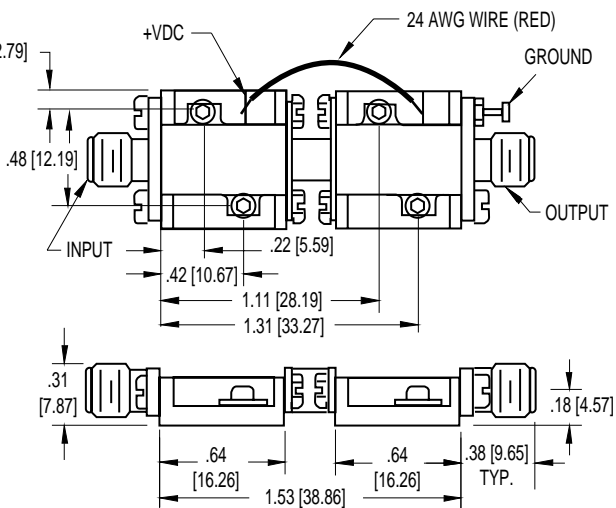

OUTLINE DRAWINGS (CONT.)

AFS SERIES TYPICAL OUTLINE HIGH INTERCEPT AMPLIFIER WITH HEATSINK

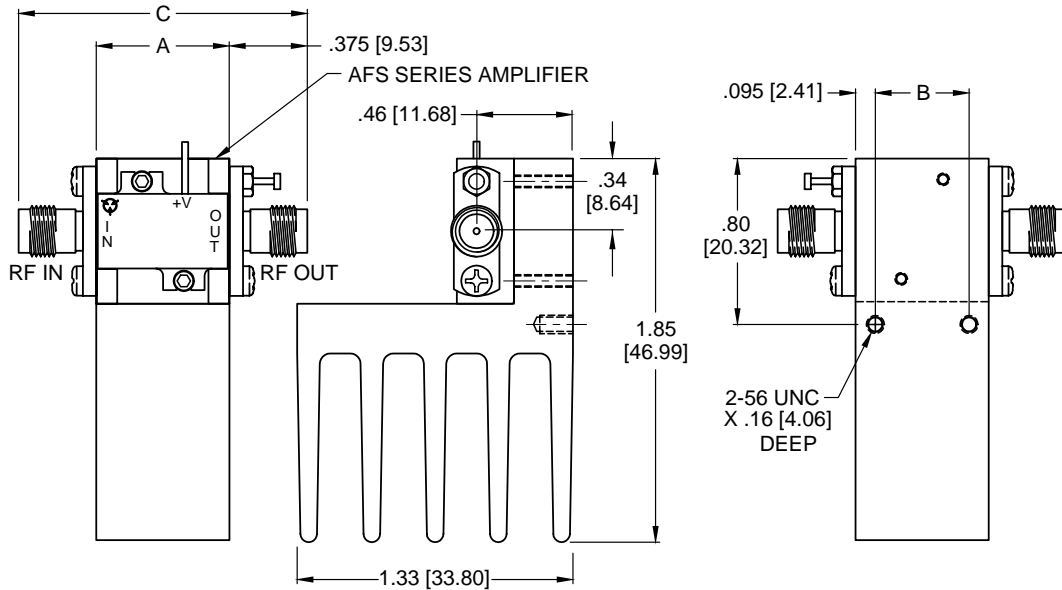

NOTE: CONTACT FACTORY FOR ACTUAL OUTLINE DIMENSIONS.

DASH NO.	DIM A	DIM B	DIM C	HEATSINK PART NUMBER
-2	.428 [10.87]	.238 [6.05]	1.18 [29.97]	113386-1
-3	.535 [13.59]	.345 [8.76]	1.29 [32.77]	113386-2
-4	.642 [16.31]	.452 [11.48]	1.39 [35.31]	113386-3
-5	.749 [19.02]	.559 [14.20]	1.50 [38.10]	113386-4
-6	.856 [21.74]	.666 [16.92]	1.61 [40.89]	113386-5
-7	.963 [24.46]	.773 [19.63]	1.71 [43.43]	113386-6
-8	1.070 [27.18]	.880 [22.35]	1.82 [46.23]	113386-7

AFD SERIES TYPICAL OUTLINE

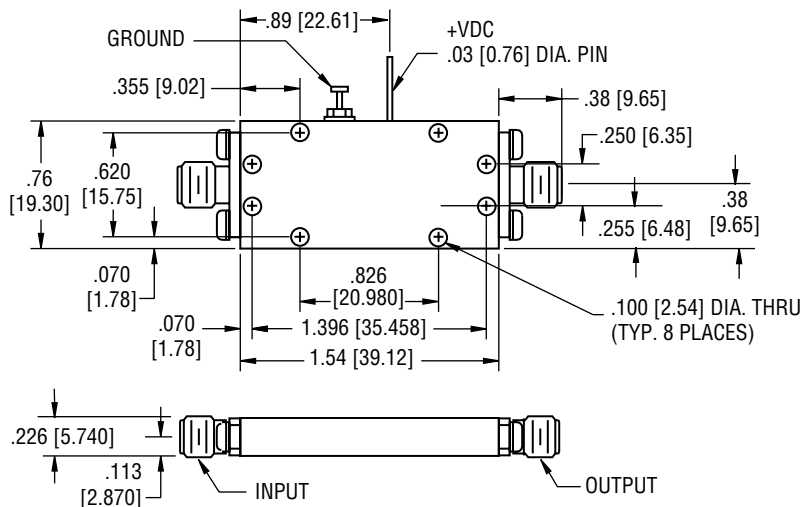

NOTE: CONTACT FACTORY FOR ACTUAL OUTLINE DIMENSIONS.

OUTLINE DRAWINGS (CONT.)

AFSD SERIES

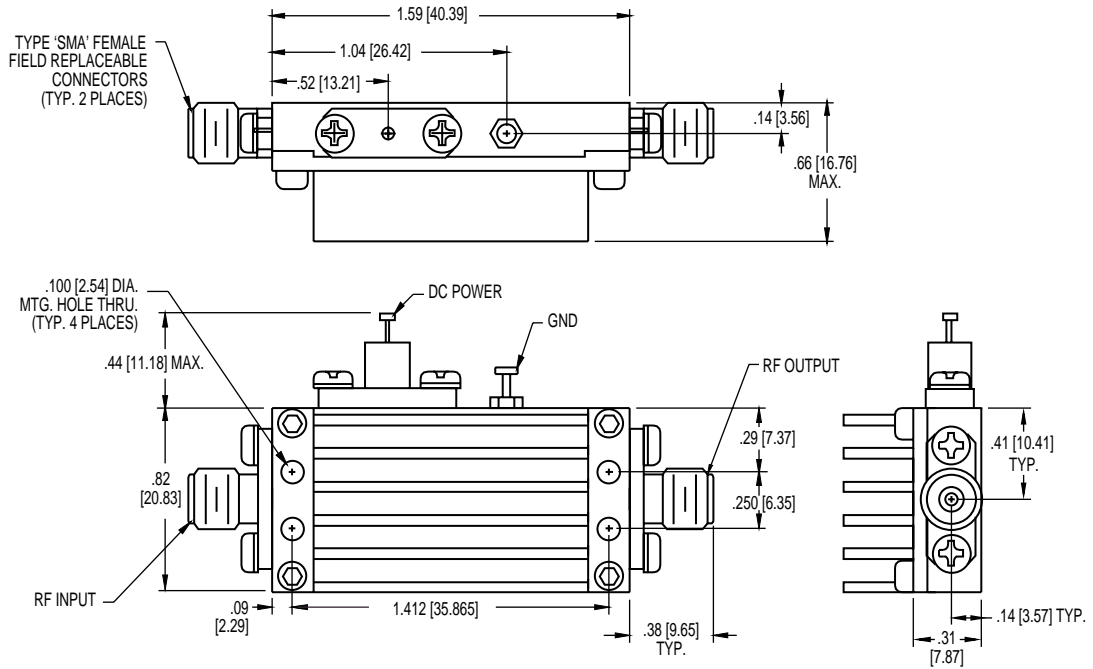

MPN SERIES

(-1)

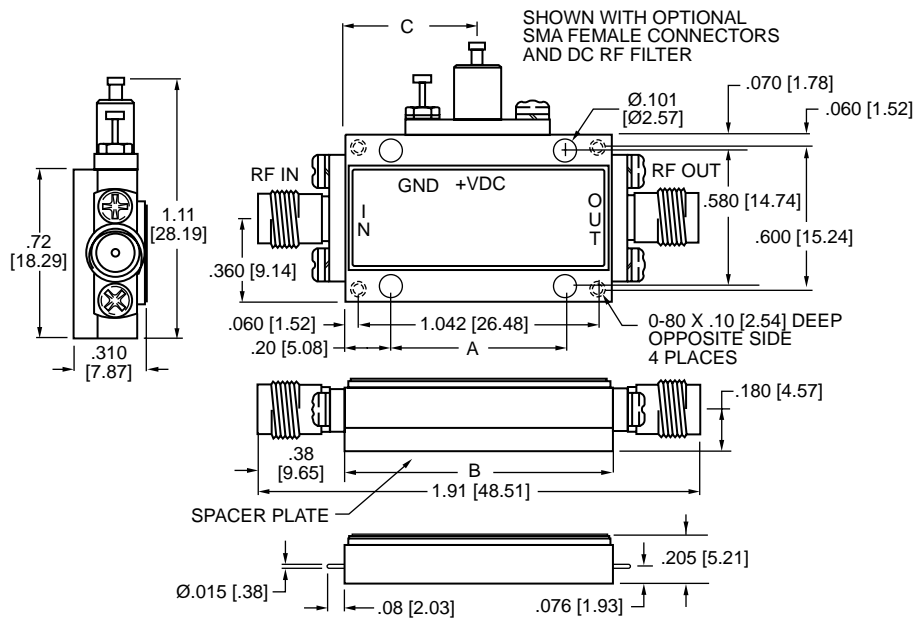

DASH NO.	DIM A	DIM B	DIM C
-1	.763 [19.38]	1.162 [29.51]	.58 [14.73]

OUTLINE DRAWINGS (CONT.)

MPN SERIES

(-2)

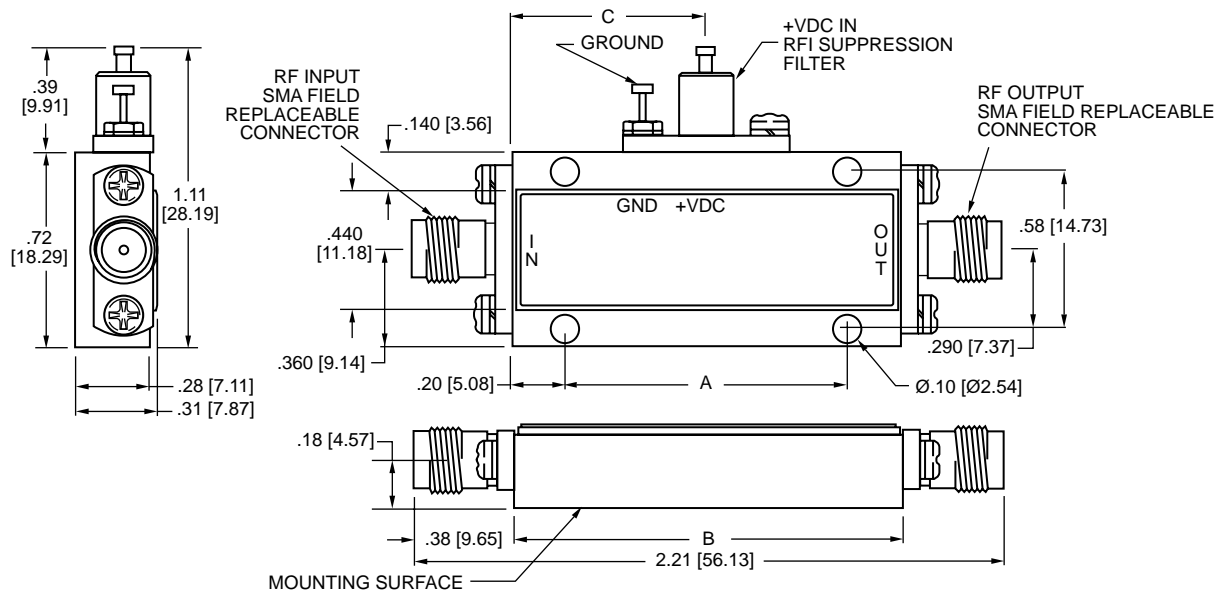

DASH NO.	DIM A	DIM B	DIM C
-2	1.062 [26.975]	1.462 [37.135]	.73 [18.54]

MPN SERIES

(-3)

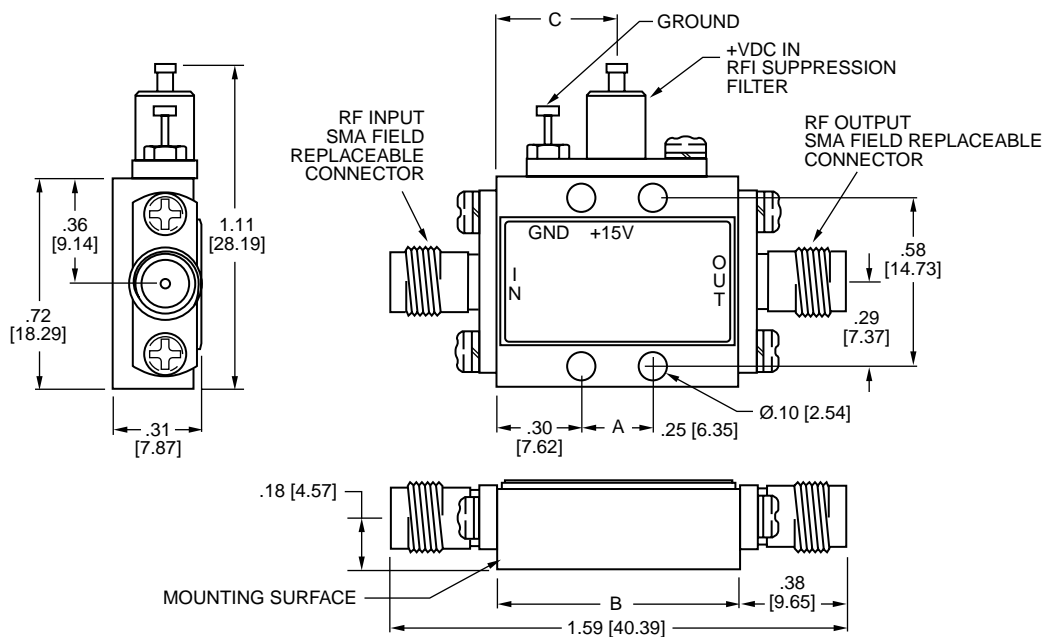

DASH NO.	DIM A	DIM B	DIM C
-3	.45 [11.43]	.84 [21.34]	.42 [10.67]

OUTLINE DRAWINGS (CONT.)

AFSM SERIES

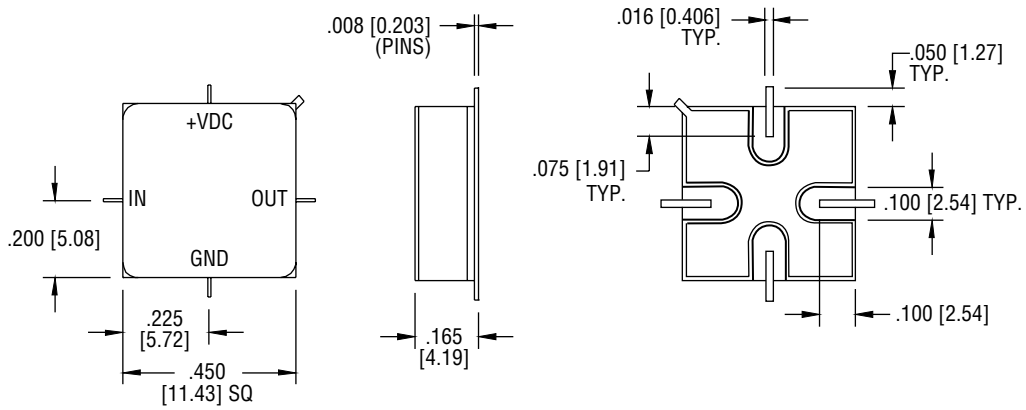

AFSM-C SERIES

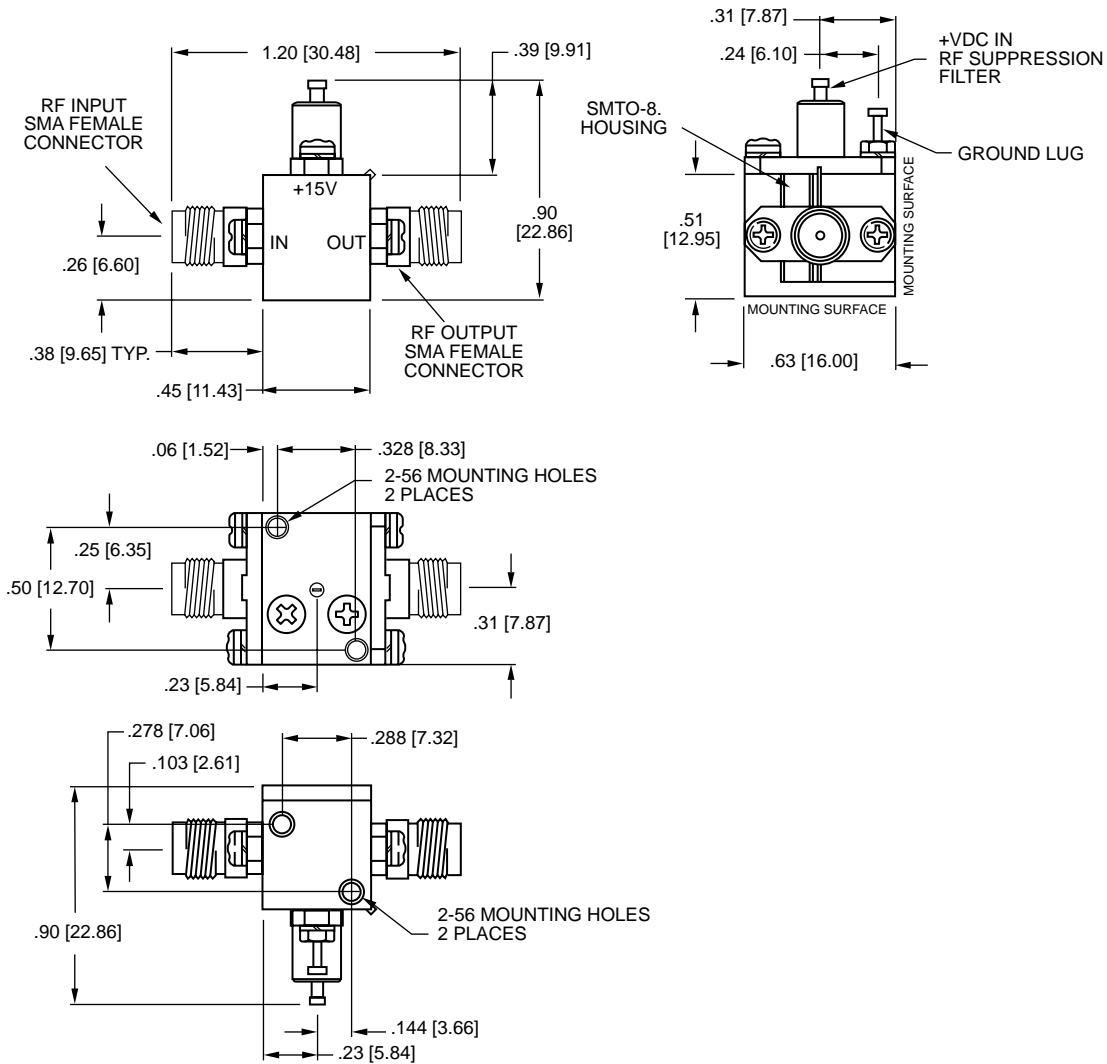

OUTLINE DRAWINGS (CONT.)

NSM SERIES

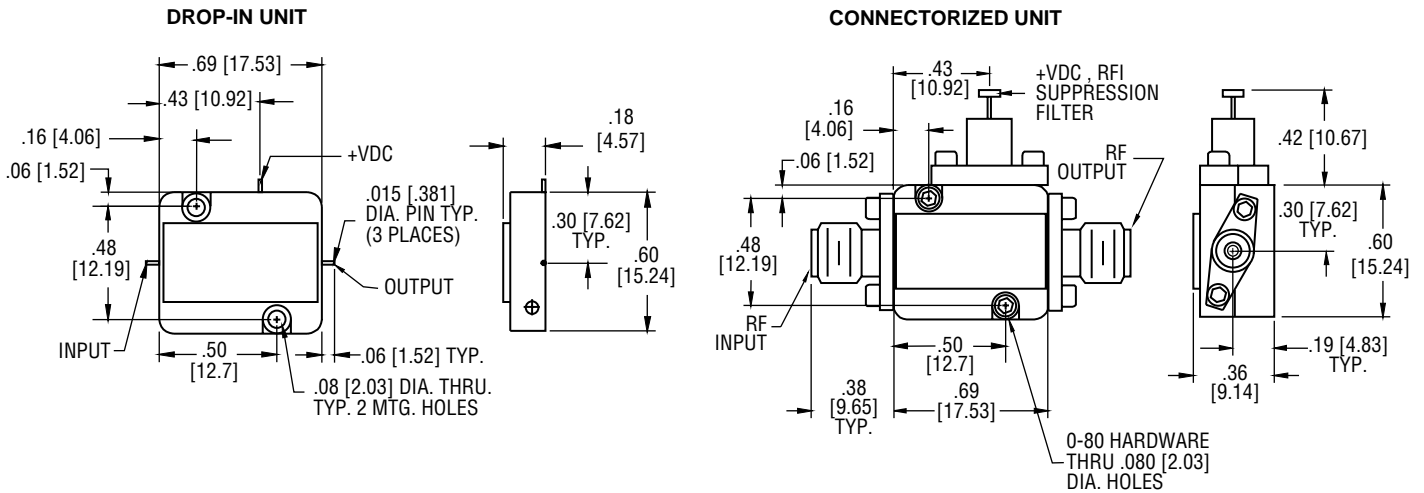

DASH NO.	DIM A	DIM B	DIM C	DIM D
-4	.69 [17.53]	.43 [10.92]	.16 [4.06]	.50 [12.70]
-6	.90 [22.86]	.64 [16.26]	.16 [4.06]	.71 [18.03]

NSP SERIES

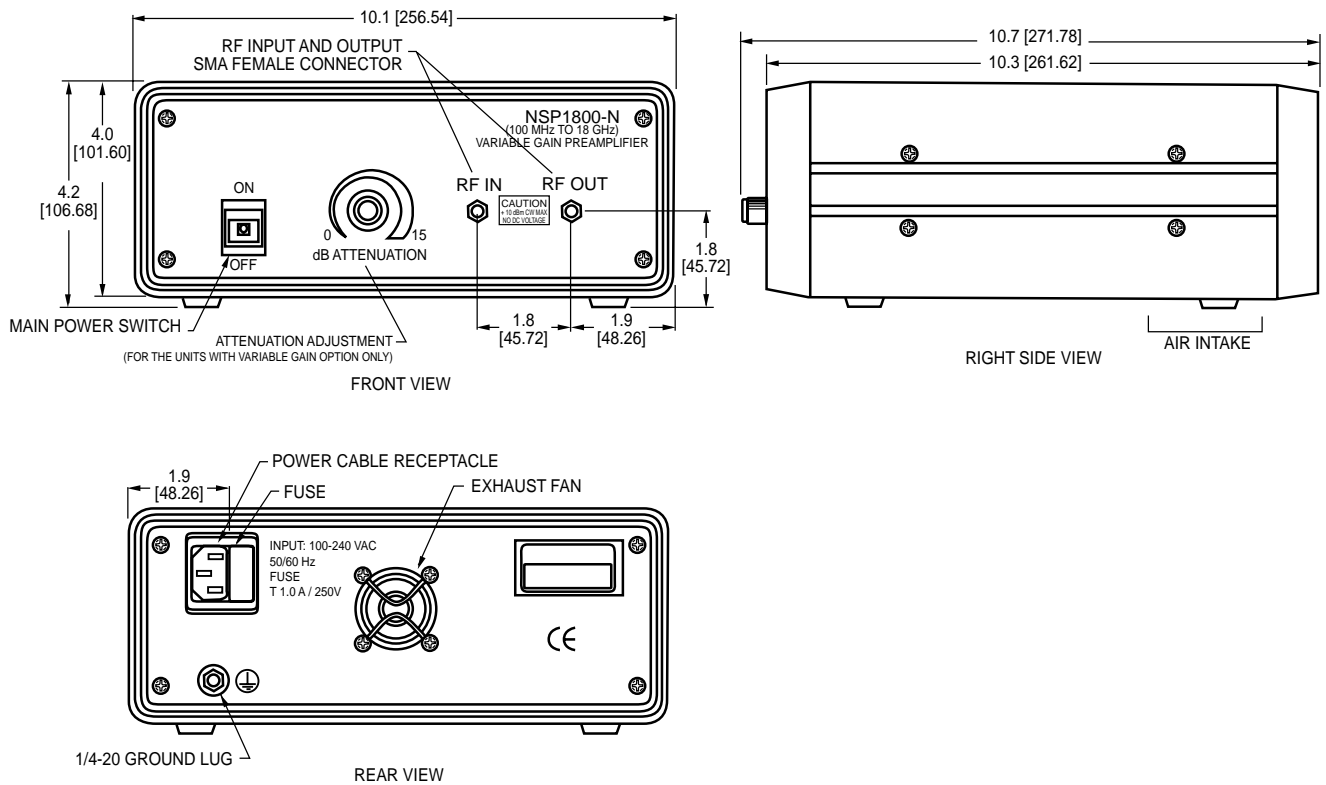

OUTLINE DRAWINGS (CONT.)

AFSX SERIES

**SMA VERSION
AFSX -4**

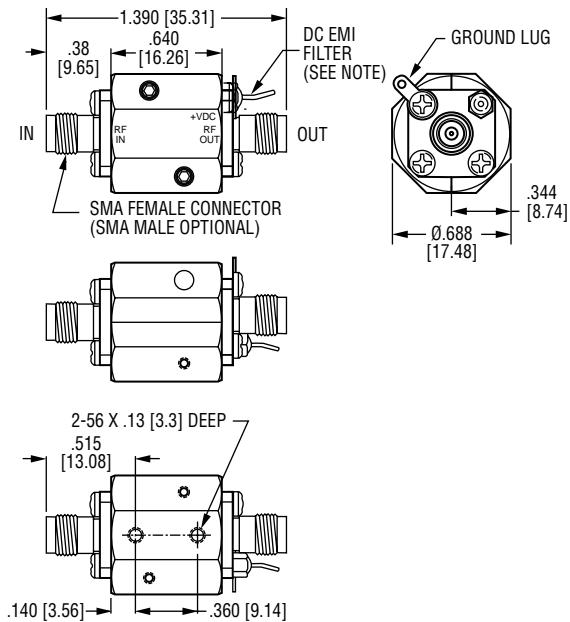

**SMA VERSION
AFSX -6**

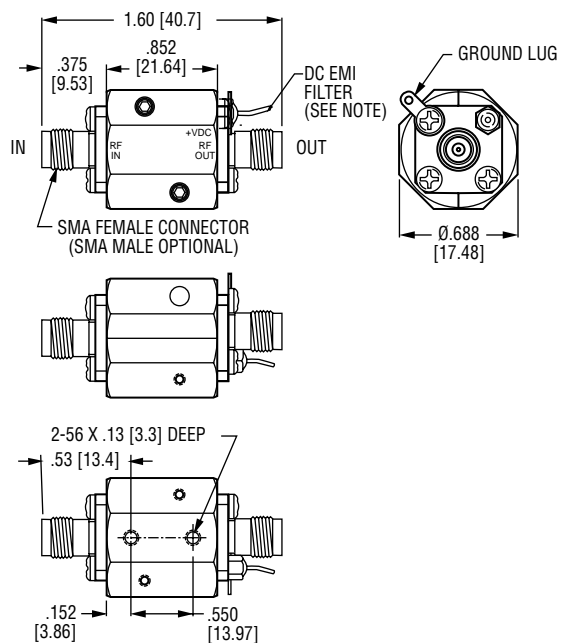

**N/TNC VERSION
AFSX -4N OR T**

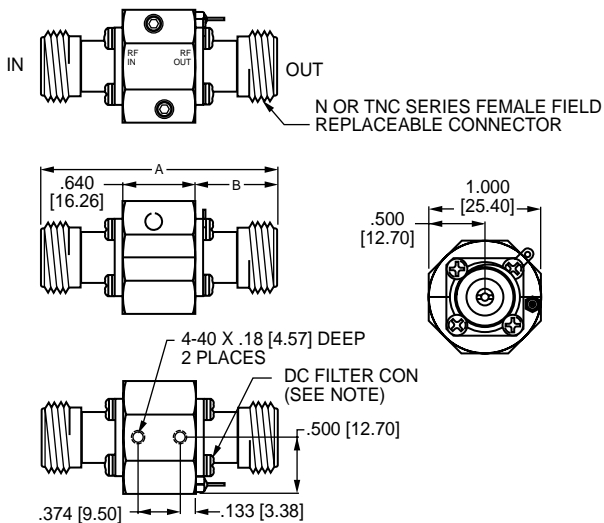

**N/TNC VERSION
AFSX -6N OR T**

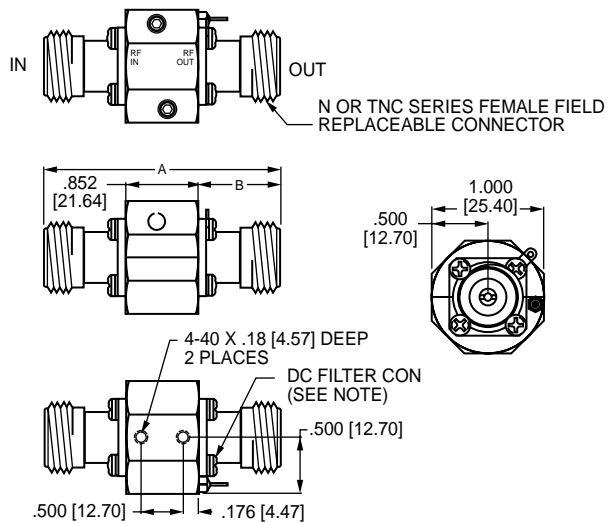

	DIM A	DIM B
N SERIES	2.110 [53.58]	.735 [18.66]
TNC	2.070 [52.58]	.715 [18.16]

	DIM A	DIM B
N SERIES	2.322 [58.97]	.735 [18.66]
TNC	2.282 [57.96]	.715 [18.16]

NOTE: DC FILTER NOT SUPPLIED WITH BTO VERSION.

OUTLINE DRAWINGS (CONT.)

AFSB SERIES

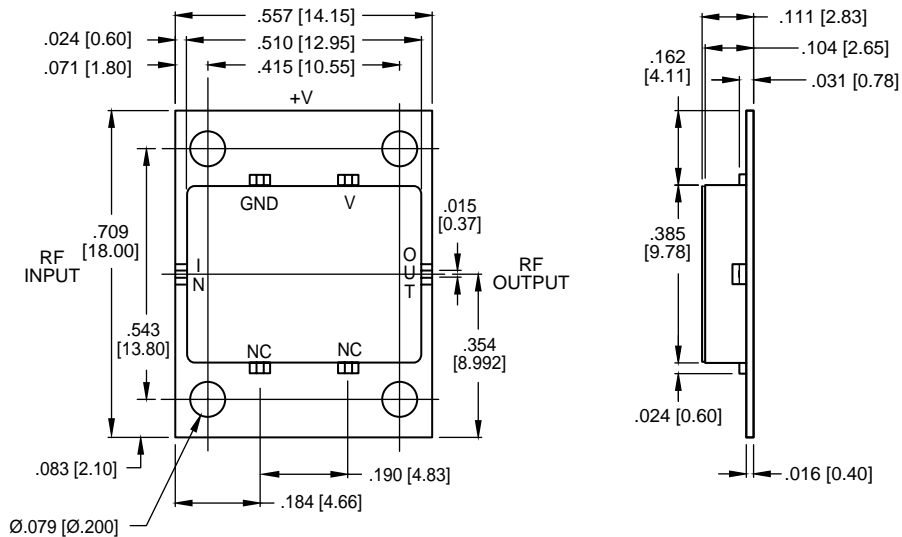

AVG SERIES

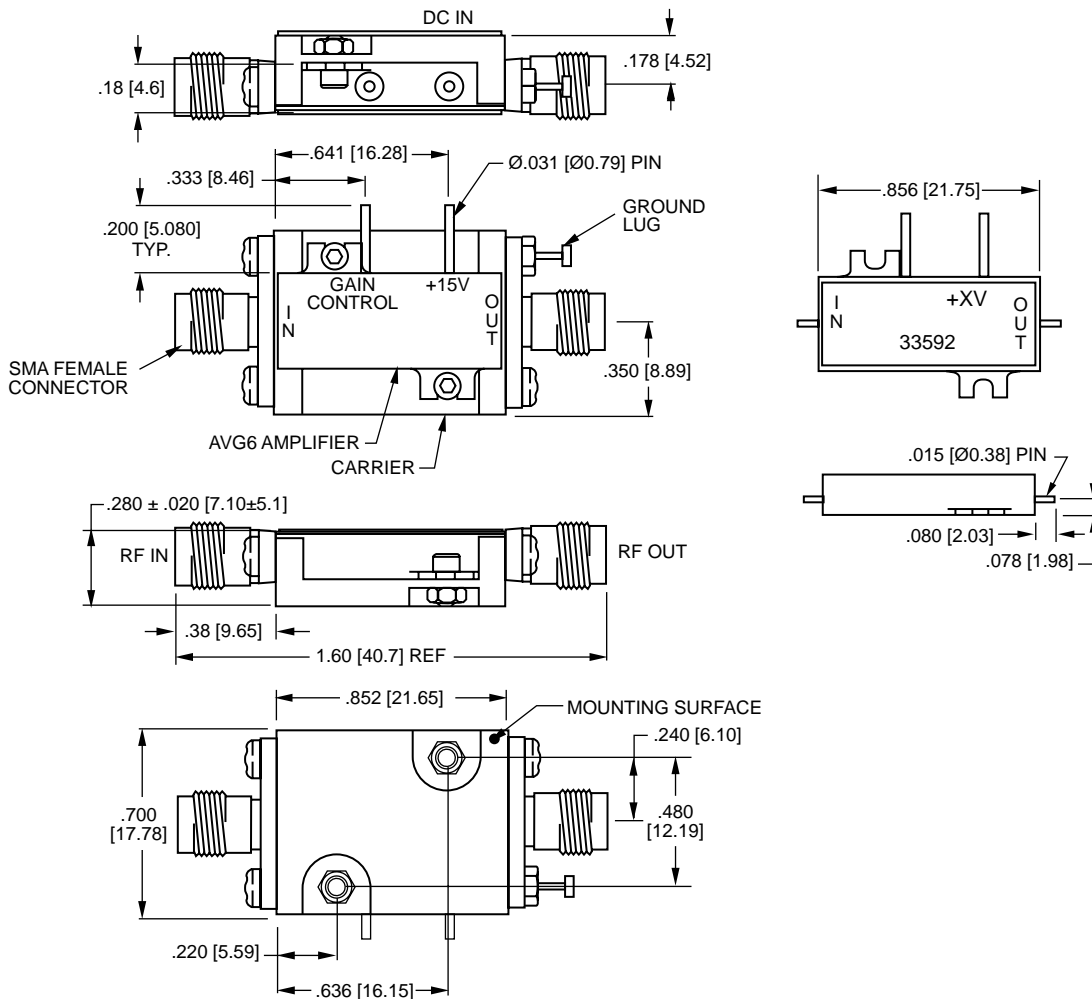

OUTLINE DRAWINGS (CONT.)

AFPD SERIES HERMETIC OUTLINE

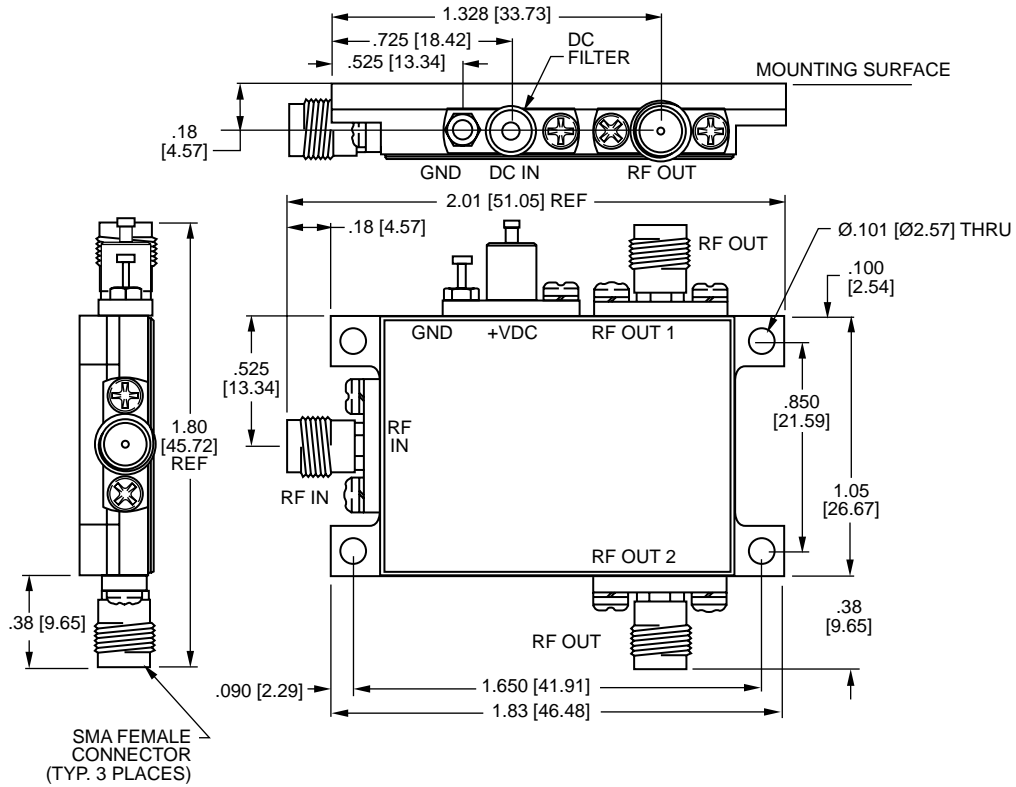

AFPD SERIES

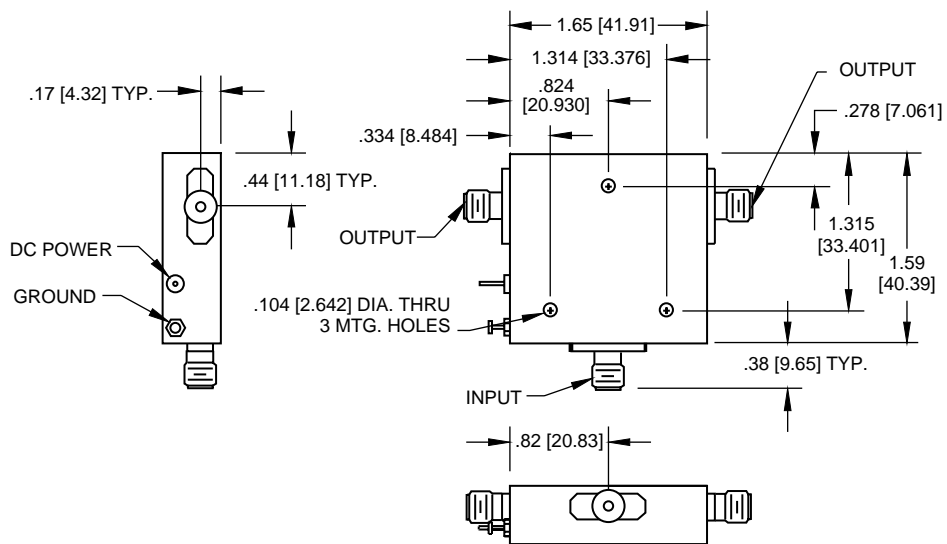

NOTE: CONTACT FACTORY FOR ACTUAL OUTLINE DIMENSIONS.

OUTLINE DRAWINGS (CONT.)

AFTL SERIES

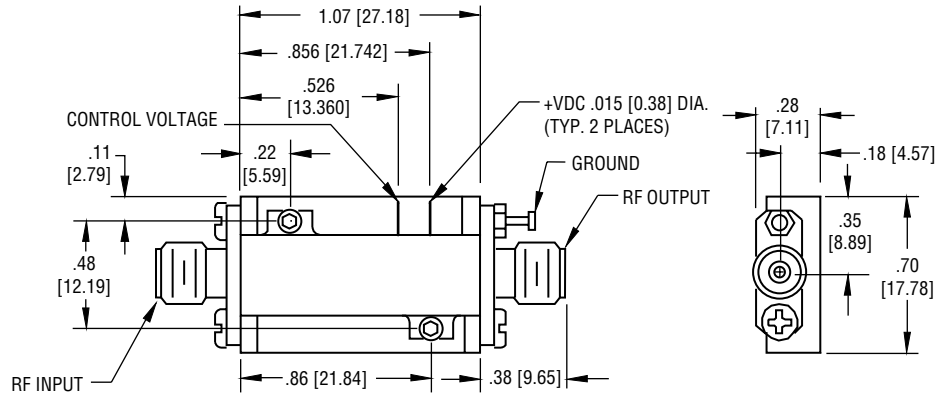

PS SERIES

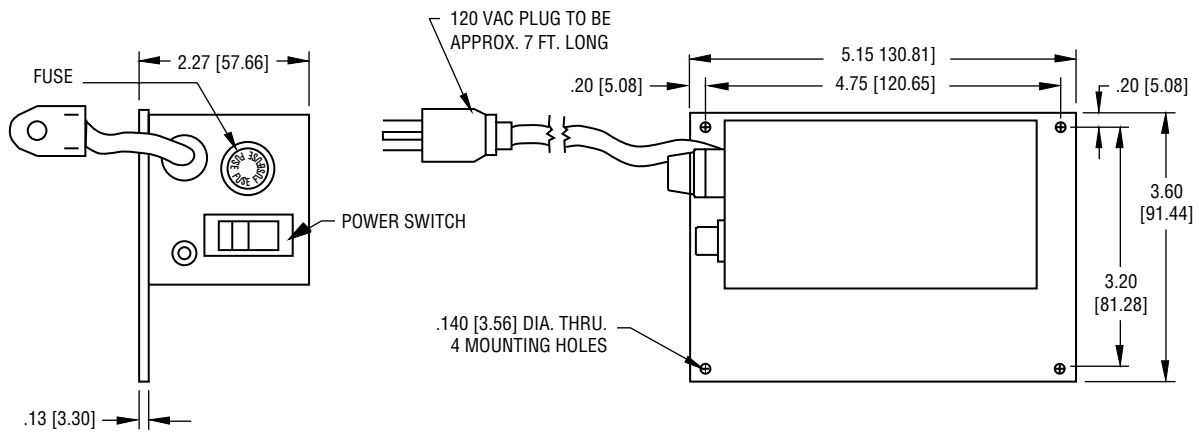

ABIT SERIES

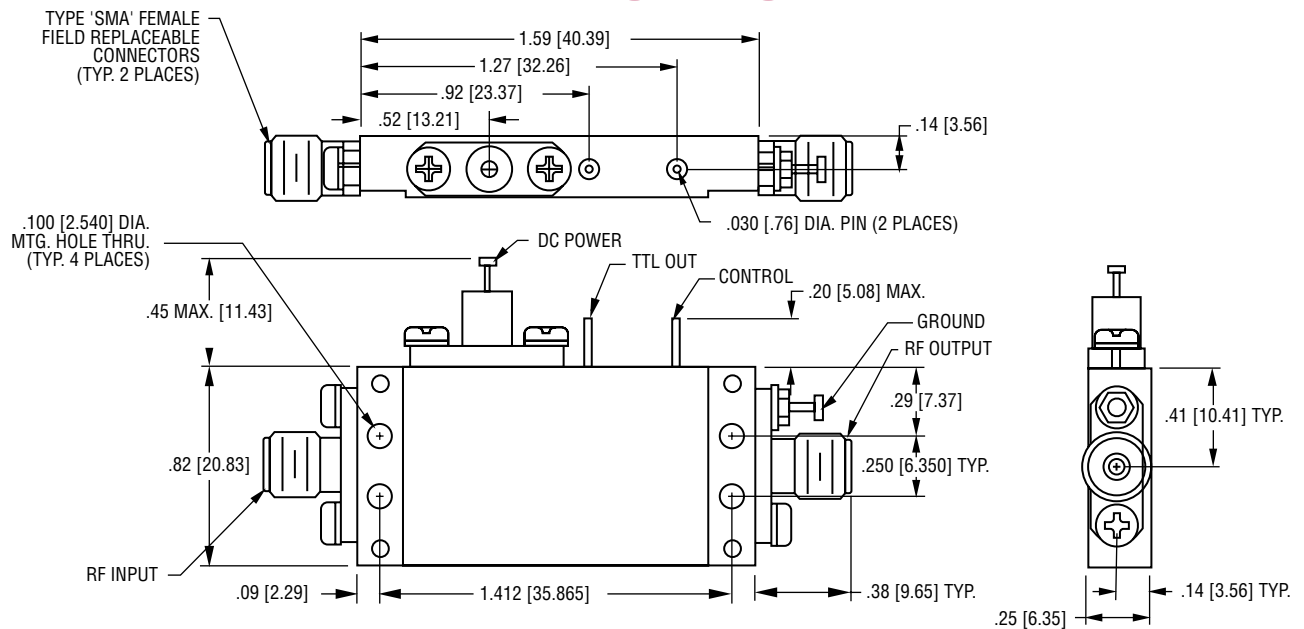

OUTLINE DRAWINGS (CONT.)

BIAS TEE

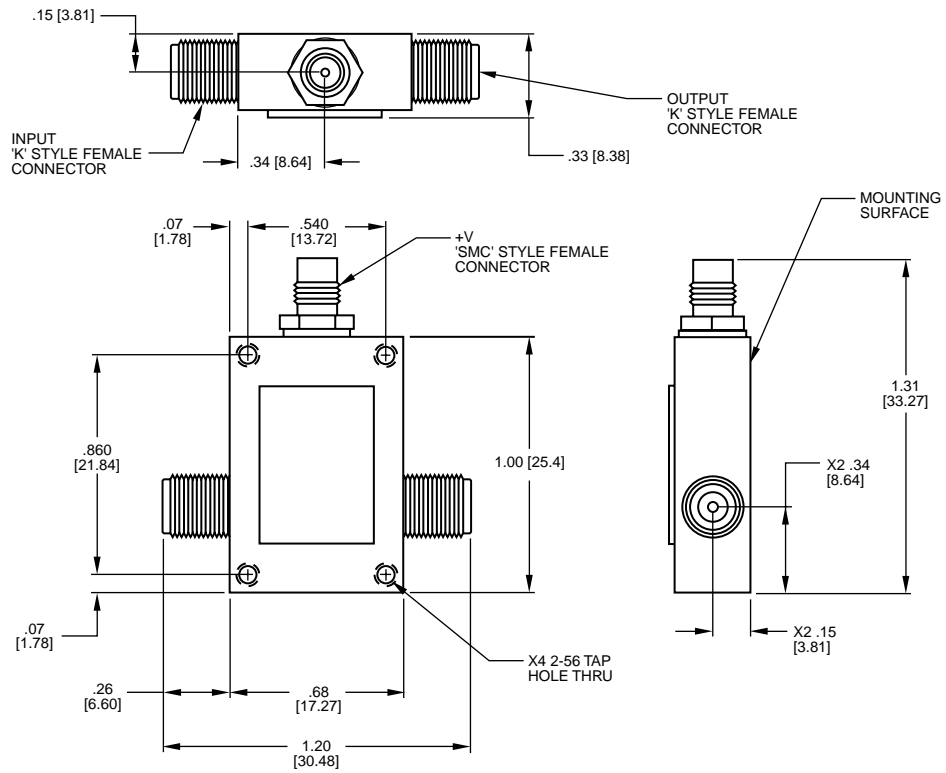

DC BLOCK

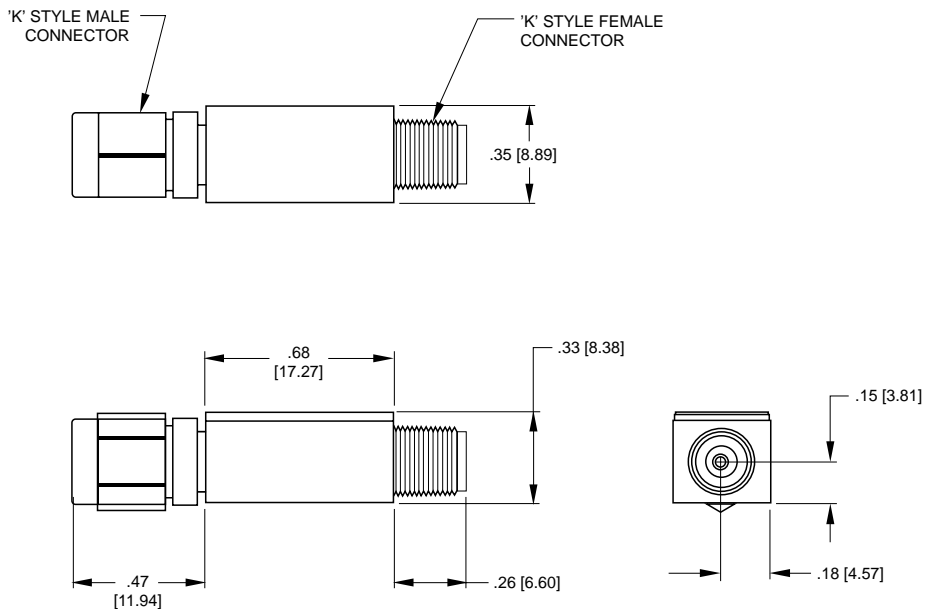

OUTLINE DRAWINGS (CONT.)

LOW FREQUENCY BIAS TEE CHASSIS

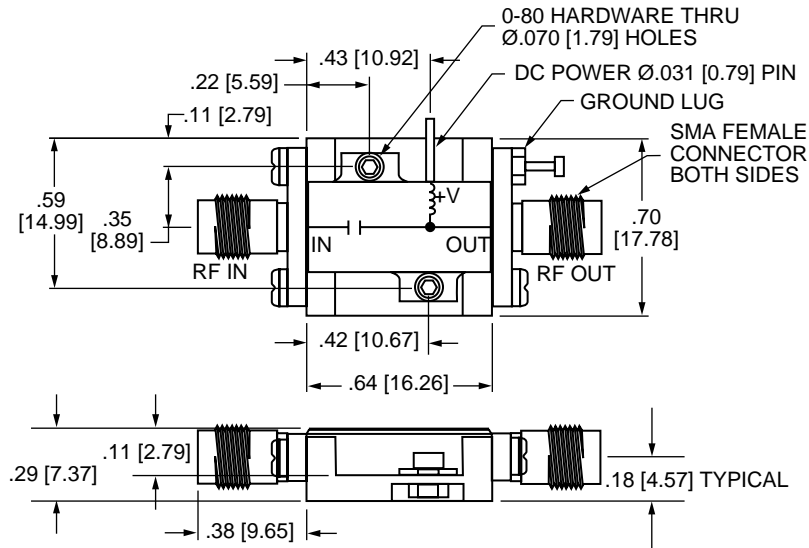

GAIN CONTROL WITH POWER MONITORING SERIES

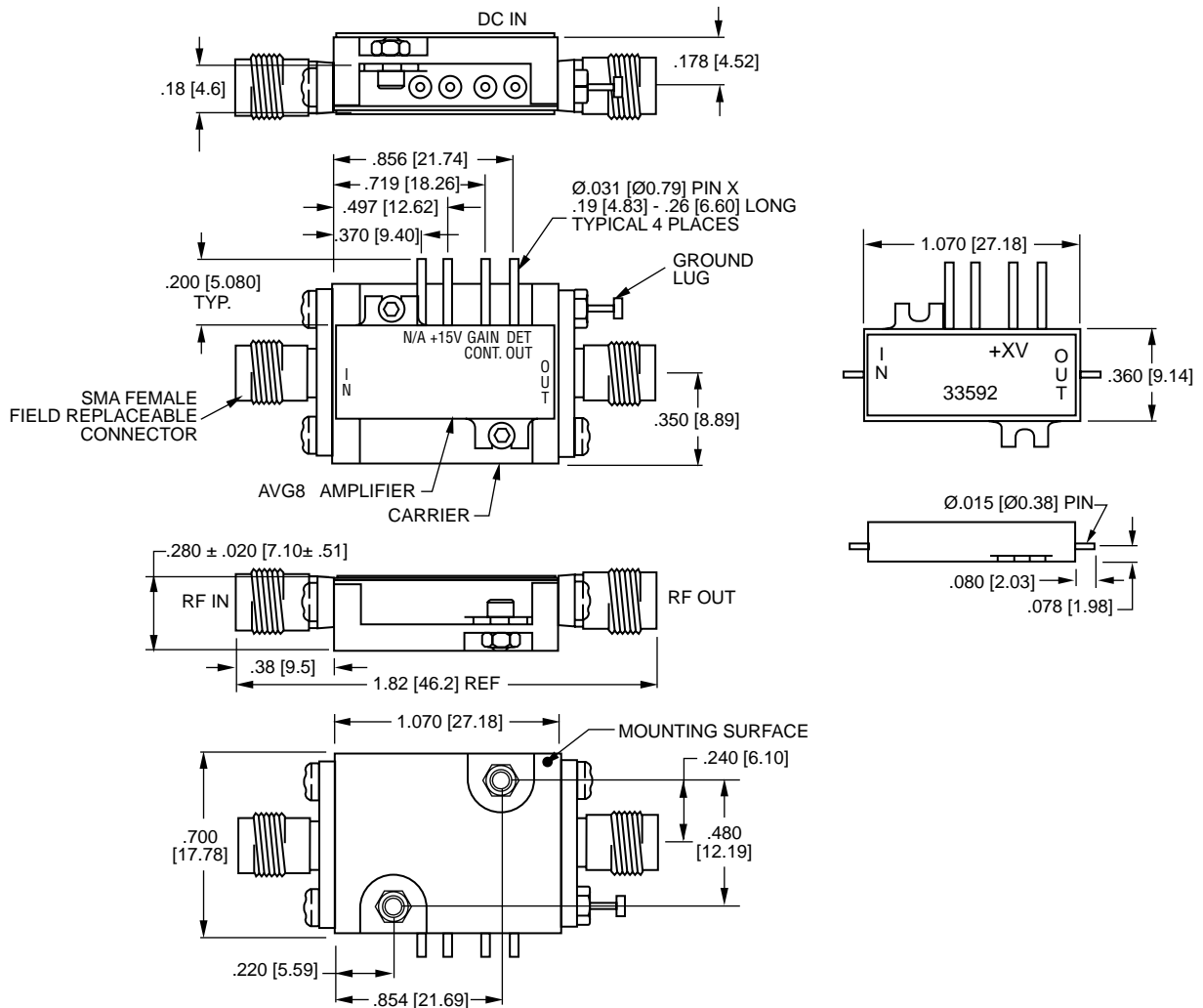

ISO 9001:2000 CERTIFIED

MITEQ attained its original ISO 9001 registration in June 1993, when fewer than 1500 companies were registered. ISO 9001 has since become a recognized standard for quality in over 90 countries. Nationally, it is accepted by an ever-increasing number of government agencies in place of longstanding military specifications covering quality and inspection criteria. Among those are MIL-Q-9858 and MIL-I-45208.



MITEQ's quality system is certified to ISO 9001 by National Quality Assurance USA (NQA), an accredited registrar of the American National Standards Institute - Registration Accreditation Board (ANSI-RAB). NQA performs a quality audit at MITEQ every six months to assure continued compliance to the standard. Additionally, MITEQ's internal auditing system, coupled with regular management reviews, assures that the quality system is effective, updated and constantly improved.

ORDERING INFORMATION

PRICING AND TERMS

A quotation on any item in the catalog is available by contacting the factory. All quotations, unless otherwise noted, are valid for 60 days from the date of issue, F.O.B. (FCA) Hauppauge, NY 11788. Pricing does not include customer or government source inspection unless otherwise noted. On international orders, an irrevocable letter of credit may be required. MITEQ accepts these credit cards:



QUANTITY DISCOUNTS

A quantity discount is generally available on most catalog items. Due to the wide variety of devices in the catalog, it is not possible to provide a standard discount schedule. When quantities are involved, please contact the factory and the appropriate information will be provided.

SHIPPING INFORMATION

Unless instructed otherwise by the customer, we will ship UPS in the U.S. F.O.B. (FCA) Hauppauge. Air freight will be used as the primary international means of shipment. Please indicate at time of purchase what method of shipment you require.

DRAWINGS AND SPECIFICATIONS

Material presented in this catalog is current at the time of printing. Mechanical and electrical requirements are subject to change. If either of these parameters is critical, please contact the factory to verify that the information is current.

APPLICATION ENGINEERING

We maintain a large support staff of engineers who are experts in specific areas of microwave technology. Each has an engineering background that combines both a formal engineering education with training and experience in product design. As further technical support, we make available the services of our engineering and scientific staff, who may be consulted on more advanced circuit designs or application problems.

RETURNED MATERIAL

For all items requiring service, regardless of warranty status, MITEQ's Customer Service department should be contacted for a Return Material Authorization (RMA) number. This can be done by either visiting our website (www.miteq.com) and requesting an RMA number online or by calling (631) 439-9300. When requesting an RMA number either over the internet or by phone, you will need to provide the model number, serial number and as much information as possible about the nature of your difficulty. All returns must arrive freight, postage, duties and handling prepaid.

SOURCE INSPECTION

Government / customer source inspection is available on any item upon receipt of the complete written confirmation of purchase order items, including the prime government contract number. Source inspection with respect to some products increases the unit price and extends delivery because of duplicate standard final inspection and testing. It is recommended wherever possible that a Certificate of Compliance be substituted for source inspection to minimize price and delivery delays.

REPAIR COSTS

Warranty repairs will be made at no cost to the customer. Units out of warranty, or those which have been mishandled, will require approval by the customer for the charges involved before the repairs can be accomplished. We will provide an estimate for the cost of the repair, which can be applied to the repair, if approval is granted. For those items that are deemed beyond repair, or where the customer may decide not to repair the unit, a handling charge will be applicable.

WARRANTY

1. MITEQ, Inc. warrants to the purchaser that each of its products, when shipped will be free from defects in material and workmanship and will perform in full accordance with applicable specifications. The limit of liability under this warranty is at MITEQ, Inc.'s option to repair or replace any product or part thereof which shall within: (a) three years of delivery for indoor equipment, (b) two years of delivery for outdoor equipment and (c) one year of delivery for integrated assemblies, custom designs or equipment having RF output powers equal to or greater than +24 dBm, be returned by the purchaser to MITEQ, Inc., at 100 Davids Drive, Hauppauge, New York, 11788, and shall, as determined by examination by MITEQ, Inc., prove defective in material and/or workmanship. Warranty returns must first be authorized in writing by MITEQ, Inc. Disassembly of any MITEQ, Inc. product by anyone other than an authorized representative of MITEQ, Inc. voids this warranty in its entirety. MITEQ, Inc. reserves the right to make changes in any of its products without incurring any obligation to make the same changes on previously delivered products.
2. Components and subsystems having been repaired by MITEQ, Inc. shall be warranted for that repair for ninety (90) days. For products that are still within the original warranty period as described above, the original warranty (if longer) will take precedence. For all SATCOM products, that portion of the system that is repaired, will be warranted for one year.
3. As a condition to the warranties provided for herein, the Buyer will prepay the shipping charges for all products returned to MITEQ, Inc. for repair and MITEQ, Inc. will pay the return shipping with the exception of rack mountable hardware returned from outside the United States in which case the buyer will pay the shipping charges.
4. The buyer will pay the cost of inspecting and testing any goods returned under the warranty or otherwise which are found to meet the applicable specifications or which are not defective or not covered by the warranty.
5. Products sold by MITEQ, Inc. shall not be considered defective or non-conforming to the Buyers' order if they (a) satisfactorily fulfill the performance requirements that were (i) provided by the Buyer to MITEQ, Inc. or (ii) as published in the Sellers' product specification literature, or (b) or in accordance with any written or verbal agreement between the Buyer and MITEQ, Inc., or (c) are in accordance with samples approved by the Buyer. This warranty shall not apply to any products or parts thereof which have been subject to accident, negligence, alteration, abuse or misuse. MITEQ, Inc. makes no warranty whatsoever in respect to accessories or parts not supplied by it.
6. Limitations of Warranty, Damages and Liability

EXCEPT AS EXPRESSLY SET FORTH HEREIN, THERE ARE NO WARRANTIES, CONDITIONS, GUARANTEES OR REPRESENTATIONS AS TO MERCHANTABILITY, FITNESS FOR A PARTICULAR PURPOSE OR OTHER WARRANTIES, CONDITIONS, GUARANTEES OR REPRESENTATIONS, WHETHER EXPRESSED OR IMPLIED, IN LAW OR IN FACT, ORAL OR IN WRITING.

MITEQ, INC.'S AGGREGATE LIABILITY IN DAMAGES OR OTHERWISE SHALL NOT EXCEED THE PAYMENT, IF ANY, RECEIVED BY MITEQ, INC. FOR THE UNIT OF PRODUCT OR SERVICE FURNISHED OR TO BE FURNISHED, AS THE CASE MAY BE, WHICH IS THE SUBJECT OF CLAIM OR DISPUTE. IN NO EVENT SHALL MITEQ, INC. BE LIABLE FOR INCIDENTAL, CONSEQUENTIAL, OR SPECIAL DAMAGES, HOWSOEVER CAUSED.

7. All matters regarding this warranty shall be interpreted in accordance with the laws of the State of New York and any controversy that cannot be settled directly shall be settled by arbitration in New York, New York in accordance with the rules then prevailing of the American Arbitration Association, and judgement upon the award rendered may be entered in any court having jurisdiction thereof.



Davids Drive • Hauppauge, NY



Oser Avenue • Hauppauge, NY

