

Common Source

ARF469AG
ARF469BG

RF POWER MOSFETS

N-CHANNEL ENHANCEMENT MODE

150V 350W 45MHz

The ARF469A and ARF469B comprise a symmetric pair of common source RF power transistors designed for push-pull scientific, commercial, medical and industrial RF power amplifier applications up to 45 MHz. They have been optimized for both linear and high efficiency classes of operation.

- **Specified 150 Volt, 40.68 MHz Characteristics:**
 - Output Power = 350 Watts.**
 - Gain = 16dB (Class AB)**
 - Efficiency = 75% (Class C)**
- **Low Cost Common Source RF Package.**
- **Low V_{th} thermal coefficient.**
- **Low Thermal Resistance.**
- **Optimized SOA for Superior Ruggedness.**

MAXIMUM RATINGS

 All Ratings: T_C = 25°C unless otherwise specified.

Symbol	Parameter	Ratings	UNIT
V _{DSS}	Drain-Source Voltage	500	Volts
V _{DGO}	Drain-Gate Voltage	500	
I _D	Continuous Drain Current @ T _C = 25°C	30	Amps
V _{GS}	Gate-Source Voltage	±30	Volts
P _D	Total Power Dissipation @ T _C = 25°C	445	Watts
R _{θJC}	Junction to Case	0.28	°C/W
T _J , T _{STG}	Operating and Storage Junction Temperature Range	-55 to 150	°C
T _L	Lead Temperature: 0.063" from Case for 10 Sec.	300	

STATIC ELECTRICAL CHARACTERISTICS

Symbol	Characteristic / Test Conditions	MIN	TYP	MAX	UNIT
BV _{DSS}	Drain-Source Breakdown Voltage (V _{GS} = 0V, I _D = 250 μA)	500			Volts
R _{DS(ON)}	Drain-Source On-State Resistance ^① (V _{GS} = 10V, I _D = 15A)		0.25	0.28	ohms
I _{DSS}	Zero Gate Voltage Drain Current (V _{DS} = 500V, V _{GS} = 0V)			25	μA
	Zero Gate Voltage Drain Current (V _{DS} = 400V, V _{GS} = 0V, T _C = 125°C)			250	
I _{GSS}	Gate-Source Leakage Current (V _{GS} = ±30V, V _{DS} = 0V)			±100	nA
g _{fs}	Forward Transconductance (V _{DS} = 25V, I _D = 6.5A)		8		mhos
V _{GS(TH)}	Gate Threshold Voltage (V _{DS} = V _{GS} , I _D = 1mA)	2		4	Volts

 **CAUTION:** These Devices are Sensitive to Electrostatic Discharge. Proper Handling Procedures Should Be Followed.

Symbol	Characteristic	Test Conditions	MIN	TYP	MAX	UNIT
C_{iss}	Input Capacitance	$V_{GS} = 0V$ $V_{DS} = 150V$ $f = 1\text{ MHz}$		2300		
C_{oss}	Output Capacitance			250		pF
C_{rss}	Reverse Transfer Capacitance			125		

FUNCTIONAL CHARACTERISTICS

Symbol	Characteristic	Test Conditions	MIN	TYP	MAX	UNIT
G_{PS}	Common Source Amplifier Power Gain	$f = 40.68\text{ MHz}$	14	16		dB
η	Drain Efficiency	$V_{GS} = 2.5V$ $V_{DD} = 150V$	70	75		%
Ψ	Electrical Ruggedness VSWR 10:1	$P_{out} = 350W$	No Degradation in Output Power			

① Pulse Test: Pulse width < 380μS, Duty Cycle < 2%

Microsemi Reserves the right to change, without notice, the specifications and information contained herein.

TYPICAL PERFORMANCE CURVES

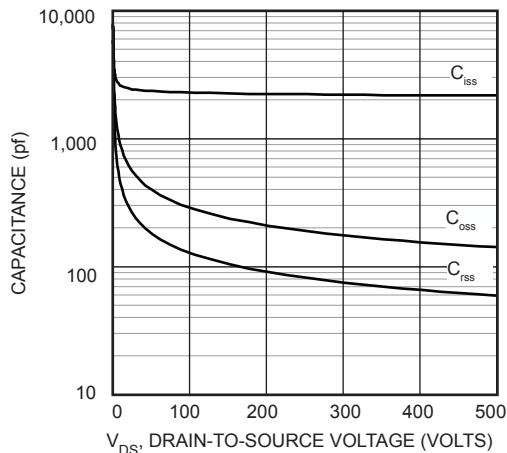

Figure 1, Typical Capacitance vs. Drain-to-Source Voltage

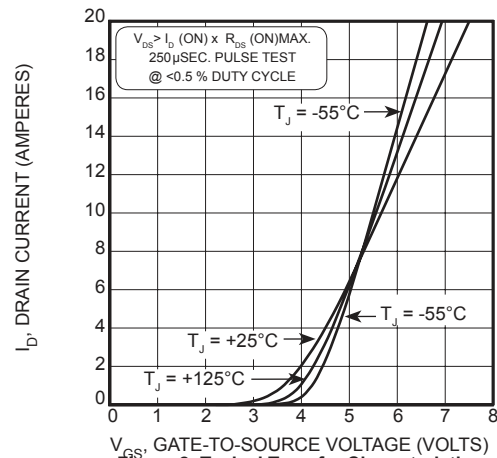

Figure 2, Typical Transfer Characteristics

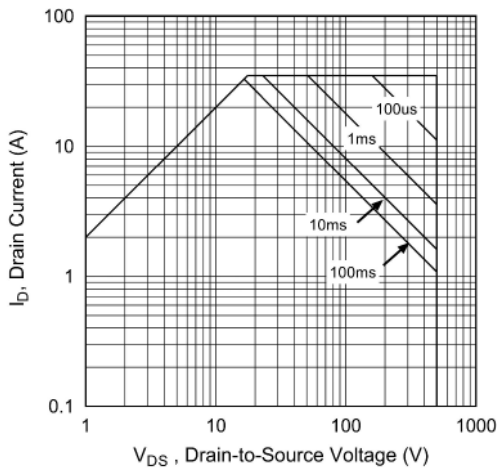

Figure 3, Typical Maximum Safe Operating Area

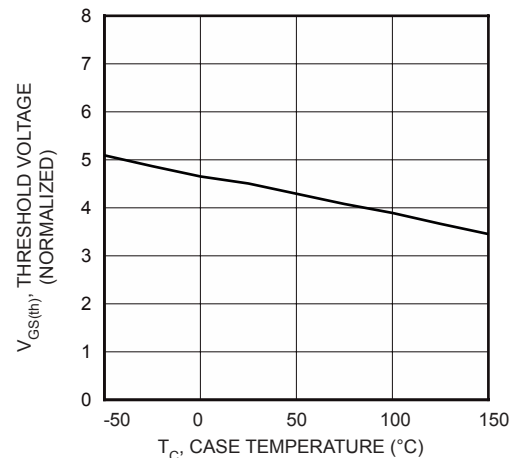

Figure 4, Typical Threshold Voltage vs Temperature

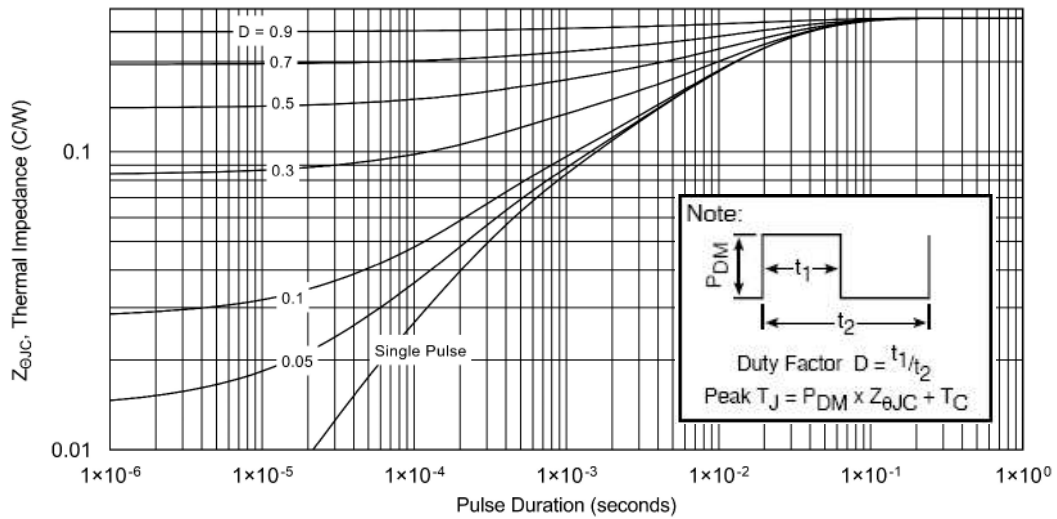
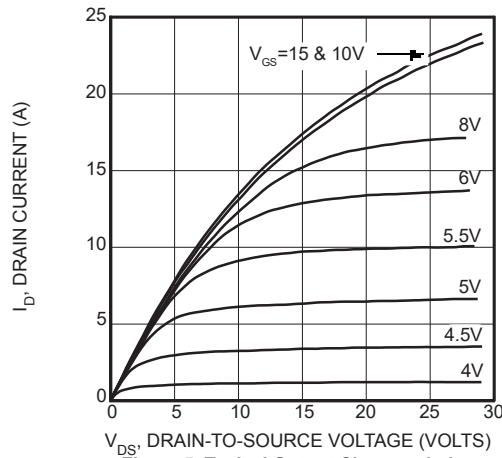
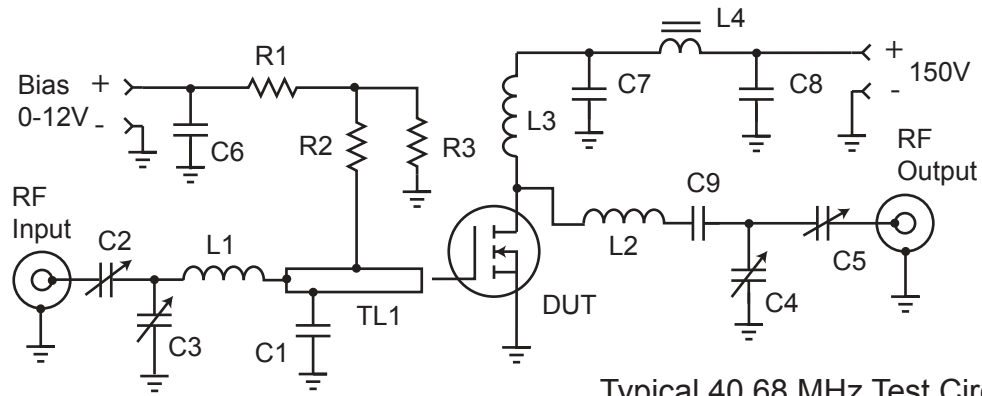

Table 1 - Typical Class AB Large Signal Input - Output Impedance

Freq. (MHz)	Z _{in} (Ω)	Z _{OL} (Ω)
2.0	18 - j 10.8	30 - j 1.5
13.5	1.3 - j 4.8	26 - j 9.6
27.1	0.4 - j 2.4	18 - j 13.1
40.7	0.2 - j 1.4	12 - j 12.4

Z_{IN} - Gate shunted with 25Ω I_{dg} = 100mA
 Z_{OL} - Conjugate of optimum load for 300 Watts output at V_{dd}=150V



Typical 40.68 MHz Test Circuit

- | | | |
|----------------------------------|--|-------------------------------|
| C1 -- 2200pF ATC 700B | L1 -- 4t #22 AWG .25"ID .25"L ~87nH | R1- R3 -- 1kΩ 0.5Ω Carbon |
| C2-C5 -- Arco 465 Mica trimmer | L2 -- 5t #16 AWG .312" ID .35"L ~176nH | TL1 -- 34Ω t-line 0.175" x 1" |
| C6-C8 -- .1 μF 500V ceramic chip | L3 -- 10t #24 AWG .25"ID ~.5μH | C1 .45" from gate pin. |
| C9 -- 3x 2200 pF 500V chips COG | L4 -- VK200-4B ferrite choke 3μH | PCB -- 0.062" FR4, Er=4.7 |

TO-264 (L) Package Outline

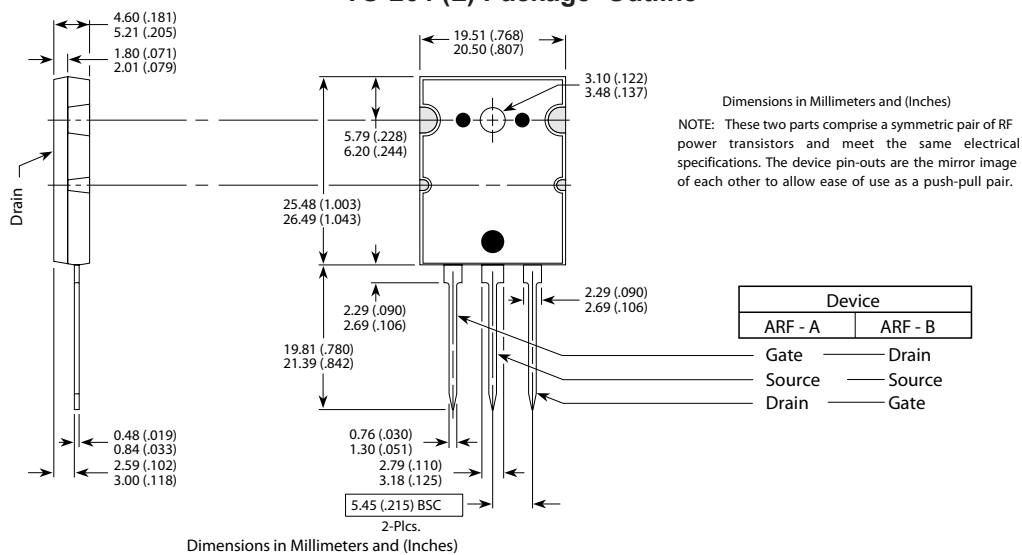



Microsemi Headquarters

One Enterprise, Aliso Viejo,
CA 92656 USA
Within the USA: +1 (800) 713-4113
Outside the USA: +1 (949) 380-6100
Sales: +1 (949) 380-6136
Fax: +1 (949) 215-4996
Email: sales.support@microsemi.com
www.microsemi.com

© 2021 Microsemi. All rights reserved. Microsemi and the Microsemi logo are trademarks of Microsemi Corporation. All other trademarks and service marks are the property of their respective owners.

Microsemi makes no warranty, representation, or guarantee regarding the information contained herein or the suitability of its products and services for any particular purpose, nor does Microsemi assume any liability whatsoever arising out of the application or use of any product or circuit. The products sold hereunder and any other products sold by Microsemi have been subject to limited testing and should not be used in conjunction with mission-critical equipment or applications. Any performance specifications are believed to be reliable but are not verified, and Buyer must conduct and complete all performance and other testing of the products, alone and together with, or installed in, any end-products. Buyer shall not rely on any data and performance specifications or parameters provided by Microsemi. It is the Buyer's responsibility to independently determine suitability of any products and to test and verify the same. The information provided by Microsemi hereunder is provided "as is, where is" and with all faults, and the entire risk associated with such information is entirely with the Buyer. Microsemi does not grant, explicitly or implicitly, to any party any patent rights, licenses, or any other IP rights, whether with regard to such information itself or anything described by such information. Information provided in this document is proprietary to Microsemi, and Microsemi reserves the right to make any changes to the information in this document or to any products and services at any time without notice.

Microsemi, a wholly owned subsidiary of Microchip Technology Inc. (Nasdaq: MCHP), offers a comprehensive portfolio of semiconductor and system solutions for aerospace & defense, communications, data center and industrial markets. Products include high-performance and radiation-hardened analog mixed-signal integrated circuits, FPGAs, SoCs and ASICs; power management products; timing and synchronization devices and precise time solutions, setting the world's standard for time; voice processing devices; RF solutions; discrete components; enterprise storage and communication solutions; security technologies and scalable anti-tamper products; Ethernet solutions; Power-over-Ethernet ICs and midspans; as well as custom design capabilities and services. Microsemi is headquartered in Aliso Viejo, California, and has approximately 4,800 employees globally. Learn more at www.microsemi.com.