

MATERIAL NUMBER (STD.)	MATERIAL NUMBER (-50)	NO. OF CIRCUITS	A	B	C	D
386371202	386371302	2	43.4 (1.71)	11.13 (.438)	25.9 (1.02)	33.3 (1.31)
386371203	386371303	3	54.6 (2.15)	22.22 (.875)	37.1 (1.46)	44.5 (1.75)
386371204	386371304	4	65.7 (2.59)	33.35 (1.313)	48.3 (1.90)	55.6 (2.19)
386371205	386371305	5	76.7 (3.02)	44.45 (1.750)	59.2 (2.33)	66.5 (2.62)
386371206	386371306	6	87.9 (3.46)	55.57 (2.188)	70.4 (2.77)	77.7 (3.06)
386371207	386371307	7	99.1 (3.90)	66.67 (2.625)	81.5 (3.21)	88.9 (3.50)
386371208	386371308	8	110.2 (4.34)	77.80 (3.063)	92.7 (3.65)	100.0 (3.94)
386371209	386371309	9	121.2 (4.77)	88.90 (3.500)	103.6 (4.08)	111.0 (4.37)
386371210	386371310	10	132.3 (5.21)	100.03 (3.938)	114.8 (4.52)	122.2 (4.81)
386371211	386371311	11	143.5 (5.65)	111.13 (4.375)	125.9 (4.96)	133.4 (5.25)
386371212	386371312	12	154.7 (6.09)	122.25 (4.813)	137.2 (5.40)	144.5 (5.69)
386371213	386371313	13	165.6 (6.52)	133.35 (5.250)	148.1 (5.83)	155.4 (6.12)
386371214	386371314	14	176.8 (6.96)	144.45 (5.687)	159.3 (6.27)	166.6 (6.56)
386371215	386371315	15	188.0 (7.40)	155.58 (6.125)	170.4 (6.71)	177.8 (7.00)
386371216	386371316	16	199.1 (7.84)	166.70 (6.563)	181.6 (7.15)	189.0 (7.44)

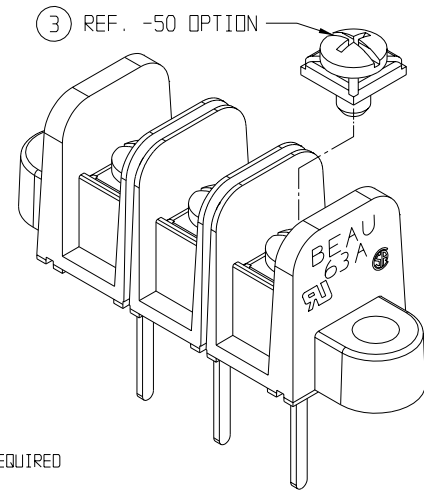
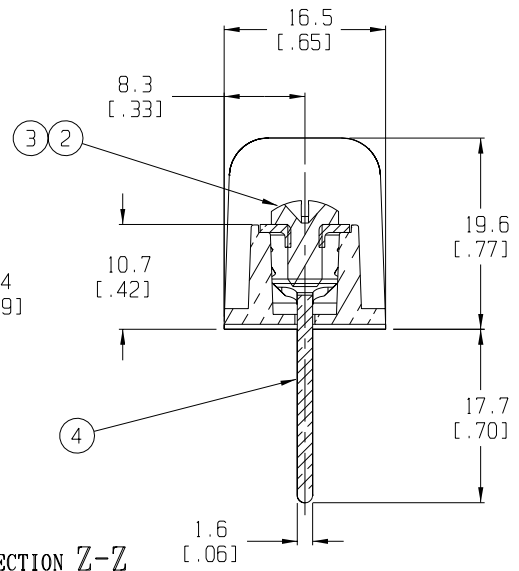
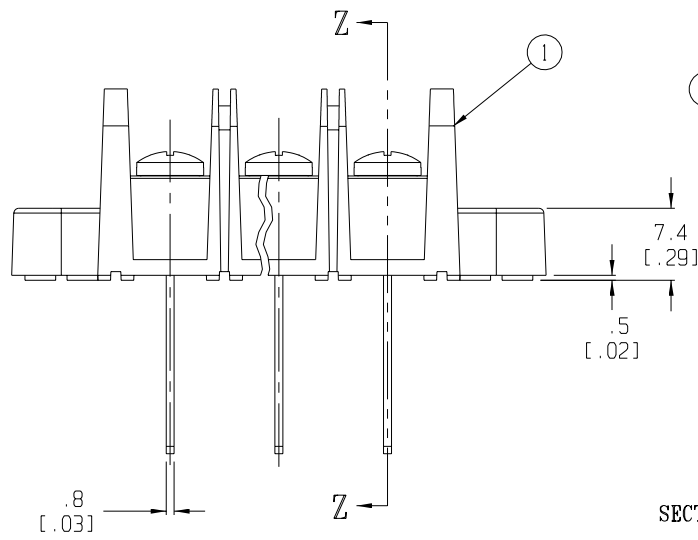

NOTES:

1. MATERIAL: SEE TABLE
2. FINISHES: SEE TABLE
3. PRODUCT SPECIFICATION: NOT REQUIRED
4. PACKAGING: NOT REQUIRED
5. MATES WITH: NONE
6. INCH DIMS ARE SHOWN IN PARENTHESIS (XXX)
7. "XX" REFERS TO QTY. OF CIRCUITS

PROJECT NO. E-656	1	-
DIMENSIONS:	SHT	REV
<input checked="" type="checkbox"/> mm <input type="checkbox"/> INCH	<input type="checkbox"/> mm <input type="checkbox"/> INCH ONLY	REVISE ON CAD ONLY

ITEM	QTY.	DESCRIPTION	MATERIAL	FINISH
4	XX	TERMINAL, WIRE WRAP, MED. LG.	BRASS	TIN PLATE
3	XX	PAN HD. SCREW & WASHER, 6-32	BRASS	BRT. ZINC PLATE
2	XX	BINDING HD. SCREW, 6-32	STEEL	BRT. ZINC PLATE
1	1	BARRIER TERMINAL STRIP	PVC	BLACK

ECO 11339 RELEASE R. STONE CH'K: APPR:	QUALITY SYMBOLS MAJOR CRITICAL SPC	GENERAL TOLERANCES: (UNLESS SPECIFIED)		SCALE 2:1	DESIGN UNITS <input type="checkbox"/> mm <input checked="" type="checkbox"/> INCH	THIRD ANGLE PROJECTION	TITLE: 63A SERIES BTS, 600V, WIRE WRAP MTG ENDS (MED. LG.)	
		4 PLACES mm ±.0015 INCH ±.0015 3 PLACES ±.038 ±.005 2 PLACES ±.13 ±.01 1 PLACE ±.3	DRAWN BY & DATE R. STONE 3-26-03 CHECKED BY & DATE	APPROVED BY & DATE			CAD FILENAME 63A7XX-75-001	MATERIAL NO. SEE CHART
REV A	DESCRIPTION	DRAFT WHERE APPLICABLE MUST REMAIN WITHIN DIMENSIONS		THIS DRAWING CONTAINS INFORMATION THAT IS PROPRIETARY TO MOLEX INCORPORATED AND SHOULD NOT BE USED WITHOUT WRITTEN PERMISSION.				SIZE B