

View X

5:1

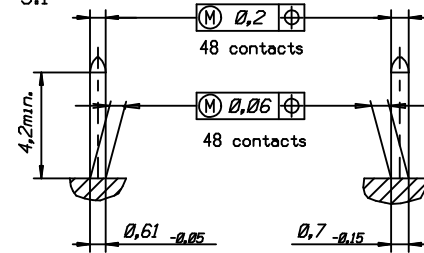

View W

5:1

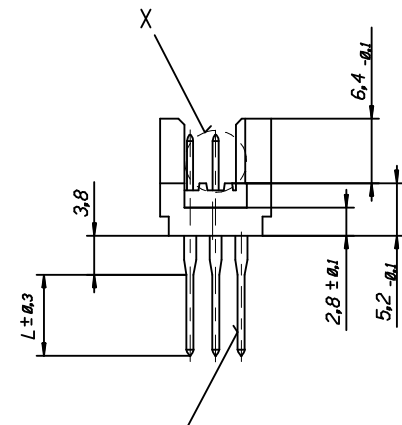
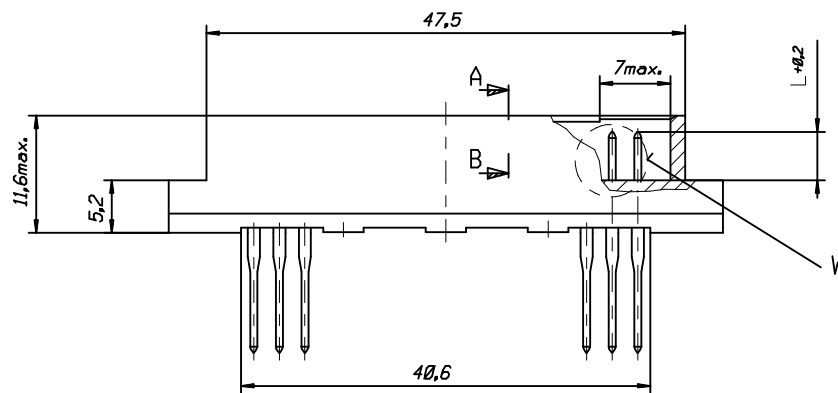
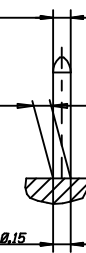

Section A - B
5:1

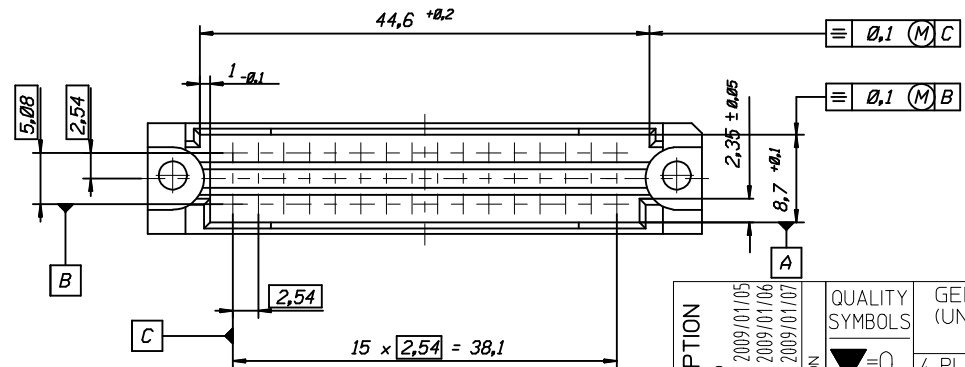
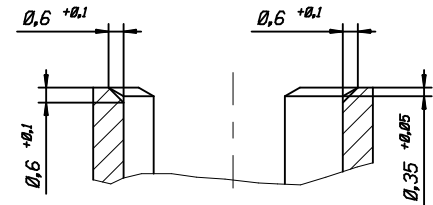

ENTER DESCRIPTION	
EC NO: I2009-0276	2009/01/05
DRW: P.J.T	2009/01/06
CHK: K.PRASAD	2009/01/06
APP: K.PRASAD	2009/01/07
REV	DESCRIPTION

QUALITY SYMBOLS	GENERAL TOLERANCES (UNLESS SPECIFIED)
▽=0	mm
∇=0	INCH

PLACES	mm	INCH
4 PLACES	± ---	± ---
3 PLACES	± ---	± ---
2 PLACES	± ---	± ---
1 PLACE	± ---	± ---
ANGULAR ± ---°		
DRAFT WHERE APPLICABLE MUST REMAIN WITHIN DIMENSIONS		

DIMENSION STYLE	
MM ONLY	
DRAWN BY	DATE
ER	1992/12/16
CHECKED BY	DATE
KN	1992/12/16
APPROVED BY	DATE
KN	1992/12/16
MATERIAL NO.	
SEE TABLE	
SIZE	THIS DRAWING CONTAINS INFORMATION THAT IS PROPRIETARY TO MOLEX INCORPORATED AND SHOULD NOT BE USED WITHOUT WRITTEN PERMISSION
A3	

SCALE	DESIGN UNITS	FIRST ANGLE PROJECTION	
2:1	METRIC		
TITLE			
48POS.MALE CONNECTOR DIN 41612 STYLE (C-PIN) DIMENSIONS			
MATERIAL NO.		DOCUMENT NO.	
SEE TABLE		609-6043-201	
SHEET NO.		1 OF 4	

48P-6043-....-6	85013-....	Wire wrap 16, 4
48P-6043-071L-7	85013-2220	yes	1/1	Wire wrap 13, 3	1, 2, 3...16	a+b+c
48P-6043-051L-7	85013-2218	yes	1/1	Wire wrap 13, 3	1, 2, 3...16	a+c
48P-6043-071V-7	85013-2206	yes	1	Wire wrap 13, 3	1, 2, 3...16	a+b+c
48P-6043-051V-7	85013-2191	yes	1	Wire wrap 13, 3	1, 2, 3...16	a+c
48P-6043-071L-8	85013-2189	yes	1/1	Wire wrap 9, 4	1, 2, 3...16	a+b+c
48P-6043-051L-8	85013-2177	yes	1/1	Wire wrap 9, 4	1, 2, 3...16	a+c
48P-6043-071V-8	85013-2165	yes	1	Wire wrap 9, 4	1, 2, 3...16	a+b+c
48P-6043-051V-8	85013-2153	yes	1	Wire wrap 9, 4	1, 2, 3...16	a+c
48P-6043-072V-7	85013-1029	yes	2	Wire wrap 13, 3	1, 2, 3...16	a+b+c
48P-6043-0731-8	85013-0232	no	2	Wire wrap 9, 4	1, 2, 3...16	a+b+c
48P-6043-072V-8	85013-0086	yes	2	Wire wrap 9, 4	1, 2, 3...16	a+b+c
48P-6043-0522-9	85013-0294	no	1	----- 2	1, 2, 3...16	a+c
48P-6043-0722-9	85013-1500	no	1	----- 2	1, 2, 3...16	a+b+c
48P-6043-0731-9	85013-0658	no	2	----- 2	1, 2, 3...16	a+b+c
✓ 48P-6043-072V-9	85013-0098	yes	2	----- 2	1, 2, 3...16	a+b+c
✓ 48P-6043-052V-9	85013-0062	yes	2	----- 2	1, 2, 3...16	a+c
48P-6043-071V-9	85013-0385	yes	1	----- 2	1, 2, 3...16	a+b+c
48P-6043-051V-9	85013-1110	yes	1	----- 2	1, 2, 3...16	a+c
Engineering number	Ordering code	Molex std.	Perform.level hard gold acc.MIL-645204	Termination / L	Contact sequence / row	

ENTER DESCRIPTION EC NO: I2009-0276 DRW:JPJT 2009/01/05 CHKD:KPRASAD 2009/01/06 APPR:KPRASAD 2009/01/07 REV DESCRIPTION	QUALITY SYMBOLS	GENERAL TOLERANCES (UNLESS SPECIFIED)	DIMENSION STYLE	SCALE	DESIGN UNITS	FIRST ANGLE PROJECTION	
	▽=0 ◻=0	mm INCH	MM ONLY	---	METRIC		
		4 PLACES ± --- ± ---	DRAWN BY DATE	TITLE			
		3 PLACES ± --- ± ---	ER 1992/12/16	48POS.MALE CONNECTOR DIN 41612 STYLE (C-PIN) DIMENSIONS			
	2 PLACES ± --- ± ---	CHECKED BY DATE	MOLEX INCORPORATED				
	1 PLACE ± --- ± ---	KN 1992/12/16	DOCUMENT NO. 609-6043-201				
	ANGULAR ± ---°	APPROVED BY DATE	SHEET NO. 2 OF 00				
		KN 1992/12/16	ENTER PART				
		MATERIAL NO.	THIS DRAWING CONTAINS INFORMATION THAT IS PROPRIETARY TO MOLEX INCORPORATED AND SHOULD NOT BE USED WITHOUT WRITTEN PERMISSION				
			DRAFT WHERE APPLICABLE MUST REMAIN WITHIN DIMENSIONS				

- 1. General : Technical Data
48pos. Male connector acc.DIN 41612 style R/2
(C-Pin)
- 2. Material :
- 2.1 Moulding material : Thermoplastic Polyester GV30 grey RAL 7032
- 2.1.1 Moulding material
burning properties acc. to UL94 V0
- 2.1.2 Resistance against
solvents : good
- 2.2 Pin contact : CuSn
- 2.2.1 Contact plating : Performance level I or II (Test acc.DIN 41612 part.5)
- 3. Printing : Part.No., date of manufacturing

Sheet	Dwg Issue	Date	Name	Change	Remark
1	Dimens. B	93/08/10	Ca	lead in chamfer changed	
2	Ord.code A1	93/08/10	Ca	add. div. Ordering code	
3	Data A	93/08/10	Ca	change of sheet no.	

ENTER DESCRIPTION EC NO: I2009-0276 DRW: P.JT 2009/01/05 CHK: K. PRASAD 2009/01/06 APPR: K. PRASAD 2009/01/07	QUALITY SYMBOLS ▽=0 ◻=0	GENERAL TOLERANCES (UNLESS SPECIFIED)		DIMENSION STYLE MM ONLY		SCALE N.T.S	DESIGN UNITS METRIC	FIRST ANGLE PROJECTION	
			mm	INCH	DRAWN BY ER	DATE 1992/12/16	TITLE 48POS.MALE CONNECTOR DIN 41612 STYLE (C-PIN) DIMENSIONS		
		4 PLACES	± ---	± ---	CHECKED BY KN	DATE 1992/12/16	MOLEX INCORPORATED		
		3 PLACES	± ---	± ---	APPROVED BY KN	DATE 1992/12/16	MATERIAL NO.	DOCUMENT NO.	SHEET NO.
2 PLACES	± ---	± ---	ANGULAR ± ---°		SEE TABLE		609-6043-201	3 OF 4	
1 PLACE	± ---	± ---	DRAFT WHERE APPLICABLE MUST REMAIN WITHIN DIMENSIONS		THIS DRAWING CONTAINS INFORMATION THAT IS PROPRIETARY TO MOLEX INCORPORATED AND SHOULD NOT BE USED WITHOUT WRITTEN PERMISSION				