

Overvoltage Protector with Bidirectional Blocking and Surge Protection

Features

- Wide Input voltage range: 3.0V to +28V
- Integrated MOSFET switch 20mΩ typical
- 5A Continuous Current
- VP Select pin
 - ▶ Over-Voltage threshold trip 13V/17V
 - ▶ VSNS clamp 16V/20V max
- Fast Over-Voltage response time 100ns
- Low Quiescent Current: 160μA (typ.)
- Integrated Protection
 - ▶ Thermal Shutdown
 - ▶ Under voltage protection (UVLO)
 - ▶ Soft-Start
 - ▶ OUT to IN Reverse Blocking
- \overline{EN} , VSNS, WRX and FLAG pins
- Integrated Surge Protection up to +/-100V
- Pb-free WLCSP 20-Bump, 0.4mm pitch
- -40°C to +85°C Temperature Range

Applications

- Smartphones and Tablets
- Mobile Internet Devices
- Peripherals

Brief Description

The KTS1676 over-voltage protection device features high current integrated N-Channel MOSFETs with an ultra-low IN to OUT on-resistance of 20mΩ (typical). Low-voltage systems on the output are protected from voltage supply faults up to +28V. An internal clamp on the input protects the device from surges up to ±100V.

An input voltage exceeding the over-voltage threshold causes the internal MOSFETs to turn off, preventing excessive voltage from damaging downstream devices.

The KTS1676 has a selectable internal fixed OVLO threshold preset to either 13V or 17V (typical) and also supports reverse bias blocking, preventing any voltage present at OUT pin feeding back into IN when the device is in the Off state. The KTS1676 also provides a selectable, always ON, clamped output voltage of 16V or 20V max.

The KTS1676 also features additional protection including enhanced ESD and thermal to protect against over-load conditions.

The device is available in a RoHS and Green compliant 20-bump, 0.4mm pitch, 2.22mm x 1.82mm WLCSP.

Typical Application

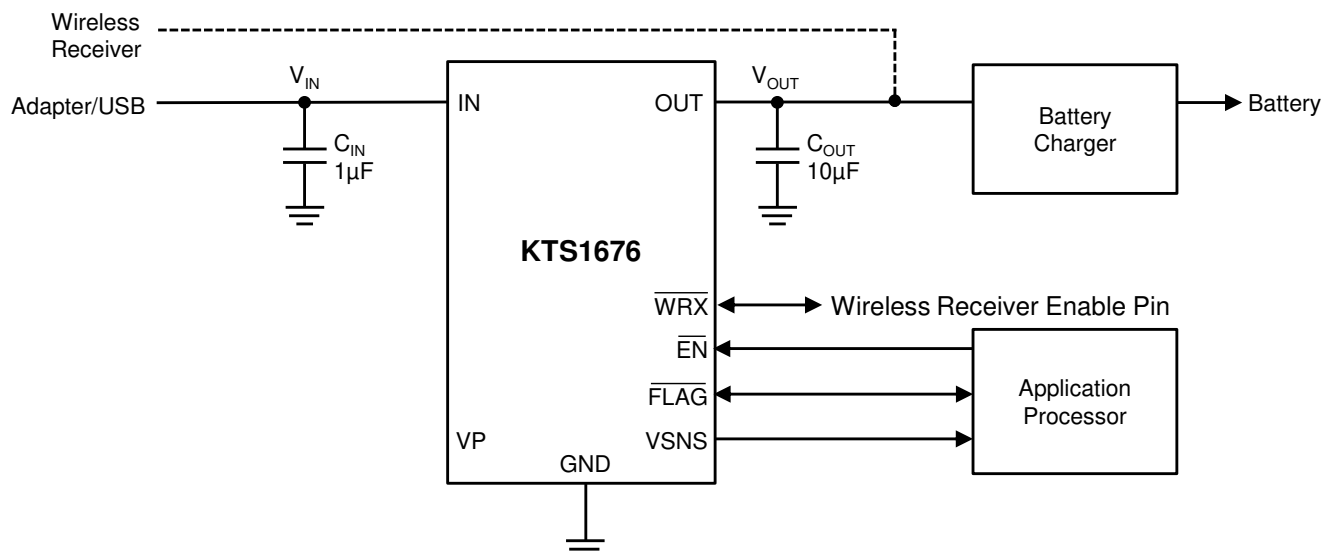

Pin Descriptions

Pin #	Name	Pin Type	Slave or Autonomous	Function
A1, A2, A3, A4, A5, B1, B2, B3	IN	Power	Both	Load switch input pin.
C1, C2, D1, D2, D3	OUT	Power	Both	Load switch output pin.
D5	\overline{WRX}	Digital I/O	Autonomous	Wireless receiver (WRx) active low logic enable pin. Slave mode: Pull this pin logic low or Pull this pin to GND. Autonomous mode: Connect this pin to WRx active low enable pin, if a system output control pin is not available.
D4	\overline{EN}	Digital Input	Slave	Active low logic enable pin. When /EN high, the switch is turned off. Slave mode: Connect this pin to System enable logic pin or tie to external GND plane. Autonomous: Pull this pin logic low or tie to external GND.
B4, B5	GND	Power	Both	Ground pin.
C4	\overline{FLAG}	Digital I/O	Autonomous	Flag pin is pulled high to indicate to the system when OTG mode can be triggered in autonomous mode. Slave mode: Pull this pin logic low, or tie to external GND. Autonomous mode: Connect to the System digital I/O pin (or equivalent) that pulls logic low to enter OTG mode when IN is connected to an OTG load and a power source is applied to OUT.
C5	VSNS	Analog Output	Slave	IN input voltage sense pin with clamping voltage set by VP pin. Slave mode: connect this pin to the battery charger input sense pin.
C3	VP	Digital Input	Both	OVP and VSNS selector pin. Connect VP to GND for a typical 17V OVP and a max. of 20V VSNS. Leave VP floating for a typical 13V OVP and a max. of 16V VSNS.

WLCSP-20

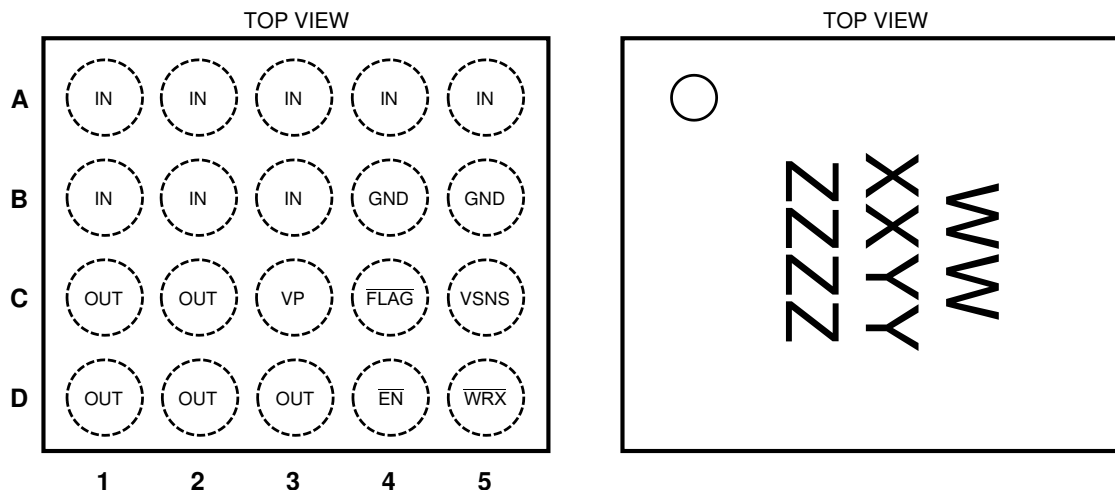

WLCSP Package 20-Bump 2.22mm x 1.82mm x 0.62mm

Top Mark

WW = Device ID Code,
 XX = Date Code, YY = Assembly Code,
 ZZZZ = Serial Number

Absolute Maximum Ratings¹

(T_A = 25°C unless otherwise noted)

Symbol	Description	Value	Units
IN	Input Voltage	-0.3 to 28	V
OUT	Output Voltage	-0.3 to 24	V
IN-OUT	IN to OUT Voltage (when OFF)	-24 to 28	V
VSNS	Input Voltage Sensing	20	V
$\overline{\text{EN}}$, $\overline{\text{FLAG}}$, $\overline{\text{WRX}}$	Enable, $\overline{\text{FLAG}}$ and $\overline{\text{WRX}}$ pins	-0.3 to 6	V
IN, OUT Current	Continuous Current	5	A
T _J	Operating Junction Temperature Range	-40 to 150	°C
T _s	Storage Temperature Range	-65 to 150	°C
T _{LEAD}	Maximum Soldering Temperature (at leads, 10 sec)	260	°C

Thermal Capabilities

Symbol	Description	Value	Units
θ_{JA}	Thermal Resistance – Junction to Ambient ²	65	°C/W
P _D	Maximum Power Dissipation at T _A ≤ 25°C	1919	mW
$\Delta P_D/\Delta T$	Derating Factor Above T _A = 25°C	-15.4	mW/°C

Ordering Information

Part Number	Marking	Operating Temperature	Package
KTS1676EUT-TR	KOXXYYZZZZ ³	-40°C to +85°C	WLCSP-20

Recommended Operating Condition⁴

Description	Value
IN Voltage Range	3.0V to 20V
OUT Voltage Range	3.0V to 18V
Ambient Temperature	-40°C to +85°C
Input capacitance (C _{IN})	Up to 10μF
OTG hot swap capacitance (C _{OTG})	Up to 200μF
Output capacitance (C _{OUT})	Up to 20μF

- Stresses above those listed in Absolute Maximum Ratings may cause permanent damage to the device. Functional operation at conditions other than the operating conditions specified is not implied. Only one Absolute Maximum rating should be applied at any one time.
- Junction to Ambient thermal resistance is highly dependent on PCB layout. Values are based on thermal properties of the device when soldered to a 4-layer board.
- XX = Date Code, YY = Assembly Code, ZZZZ = Serial Number.
- The device is not guaranteed to function outside of recommended operating condition.

Electrical Characteristics⁵

$V_{IN}/V_{OUT} = 5V$. Unless otherwise noted, the *Min* and *Max* specs are applied over the full operation temperature range of $-40^{\circ}C$ to $+85^{\circ}C$, while *Typ* values are specified at room temperature ($25^{\circ}C$).

Symbol	Description	Conditions	Min	Typ	Max	Units	
INPUT, OVP (IN to OUT)							
V_{IN}	Input Operating Supply voltage		3.0		20.0	V	
V_{OUT}	Output Operating Supply voltage		3.0		18.0	V	
V_{UVLO}	Input /Output UVLO rising threshold	Initiates soft-start after deglitch time	2.3	2.7	2.9	V	
I_{OUT}, I_{OTG}	Continuous output current				5	A	
V_{OVP}	Input OVP rising threshold	$V_{IN} > V_{OVP}$ enters Fault mode	VP = GND	16	17	18	V
			VP = FLOAT	12	13	14	V
$V_{UVLO/OVP-HYS}$	UVLO and OVP Hysteresis	Falling V_{IN}		0.2		V	
$V_{IN-CLAMP}$	Input Clamp Voltage	$I_{IN} = 10mA, T_A = +25^{\circ}C$	28	32		V	
$R_{DSON (IN-OUT)}$	Switch ON Resistance	$I_{IN} = 1A, T_A = +25^{\circ}C$		20	30	m Ω	
I_{Q-IN}	Input quiescent current, Standby/Fault state	$\overline{EN} = High$		160		μA	
I_{DD-IN}	Input operating current	$\overline{EN} = Low, I_{OUT} = 0mA$		160		μA	
I_{Q-OUT}	Output quiescent current, Standby/Fault state	OTG-mode, $\overline{EN} = High$		150		μA	
I_{DD-OUT}	Output operating current	OTG-mode, $\overline{EN} = Low, No load$		170		μA	
$I_{QIN-GND(CLAMP)}$	Clamping IN quiescent current	$V_{IN} = 28V; V_{OUT} = 0V to 6V$		0.3	5	mA	
R_{DIS}	OUT discharge resistance	Measured from OUT to GND during discharge event		650		Ω	
$V_{IN-OUT(Float)}$	OUT float voltage	Standby state, $\overline{FLAG} = high$ and/or $\overline{EN} = high; V_{IN} = 4.5V to 16V$			2	V	
$V_{OUT-IN(Float)}$	IN float voltage	OTG state, $\overline{FLAG} = high$ and/or $\overline{EN} = high; V_{OUT} = 4.5V to 16V$			2	V	
VSNS							
V_{VSNS_DROP}	VSNS voltage drop when loaded	$I_{VSNS} = 20mA, T_A = +25^{\circ}C$		20	30	mV	
V_{CLAMP}	VSNS Clamp Voltage	$V_{IN} = 20V, V_{\overline{EN}} = 0V$	VP = GND		18	20	V
			VP = FLOAT		14	16	V

5. KTS1676 is guaranteed to meet performance specifications over the $-40^{\circ}C$ to $+85^{\circ}C$ operating temperature range by design, characterization and correlation with statistical process controls.

Electrical Characteristics (continued)⁵

Symbol	Description	Conditions	Min	Typ	Max	Units
TIMING CHARACTERISTICS						
t _{DEB}	Input debounce time	V _{UVLO} < V _{IN} < V _{OVP} , \overline{EN} = low, time delay between V _{IN} rising and \overline{WRX} rising		50		ms
t _{DIS}	Discharge time	Time after debounce time \overline{WRX} rising to V _{OUT} soft-start		50		ms
t _{SST}	Soft-start time	Bidirectional IN to OUT or OUT to IN, time is from 20% to 80% of input		0.5	1.0	ms
t _{OVP-DLY}	Switch turn-off response time	V _{IN} > V _{OVP} to V _{OUT} stop rising		70		ns
t _{DELAY}	Logic pin enable delay: \overline{EN} , \overline{FLAG}	Time delay from \overline{EN} , \overline{FLAG} enable/disable load switch, excluding soft-start		200		μs
DIGITAL SIGNALS						
V _{IL}	Digital Logic Thresholds; Logic input pins: \overline{EN} , \overline{FLAG} , \overline{WRX}	Input logic low			0.4	V
V _{IH}		Input logic high	1.4			V
V _{OL}	Output voltage: \overline{FLAG} , \overline{WRX}	Output logic low, Sinking = 1mA			0.4	V
V _{OH}		Output logic high, no load	2.4	3.25	3.6	V
R _{OH}	Pull-up resistance: \overline{FLAG} , \overline{WRX}			400		kΩ
R _{EN}	\overline{EN} Pull-down resistor			400		kΩ
ESD PROTECTION (IEC61000-4-2)						
V _{ESD}	Human Body Model (HBM)	All pins		±2		kV
	IEC61000-4-2 Contact discharge	IN pin		±8		
	IEC61000-4-2 Air gap discharge	IN pin		±15		
Thermal Shutdown						
t _{J-TH}	IC junction thermal shutdown threshold			150		°C
	IC junction thermal shutdown hysteresis			15		°C

Typical Characteristics

$V_{IN}/V_{OUT} = 5V$, $C_{IN} = 1\mu F$, $C_{OUT} = 10\mu F$, \overline{WRX} floating (high), \overline{FLAG} floating (high), \overline{EN} floating (low), $V_P = GND$ (17V V_{OVP}), Temp = 25°C unless otherwise specified.

**Forward Supply Current vs. VIN
(Switch on)**

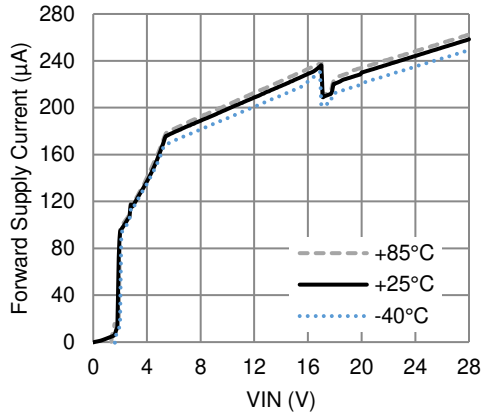

**Forward Blocking Supply Current vs. VIN
(Switch off, EN = high)**

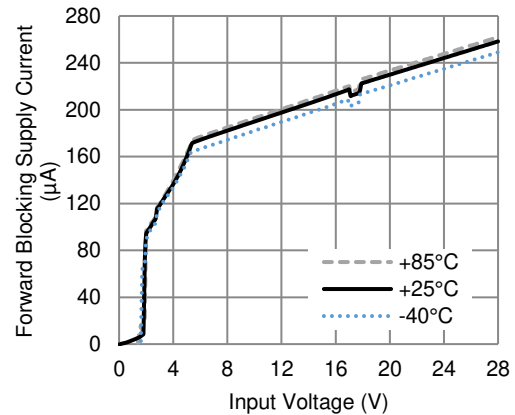

**Reverse Supply Current vs. VOUT
(Switch on, FLAG = low)**

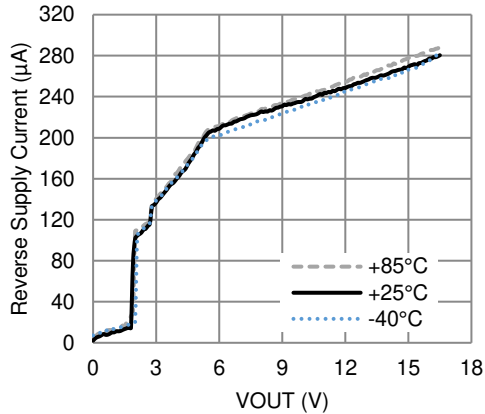

**Reverse Blocking Supply Current vs. VOUT
(Switch off, FLAG = high)**

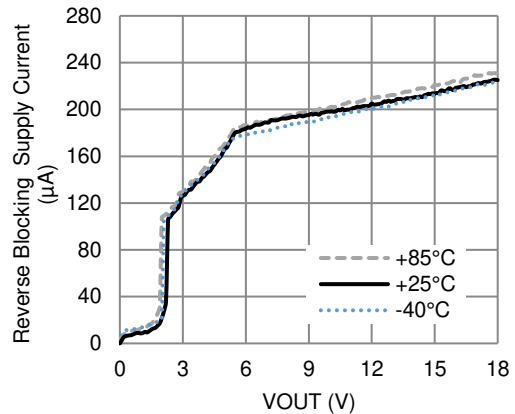

**Normalized $R_{DS(on)}$ vs Output Current
($V_{IN} = 5V$)**

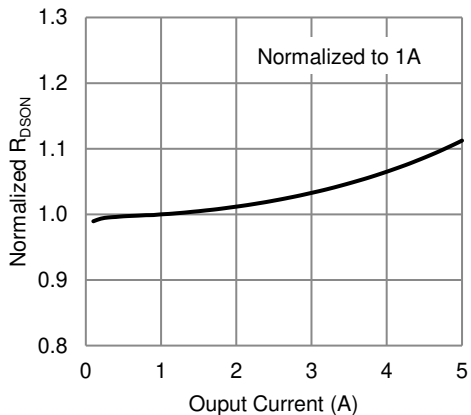

**Normalized $R_{DS(on)}$ vs. Temperature
($I_{OUT} = 1A$)**

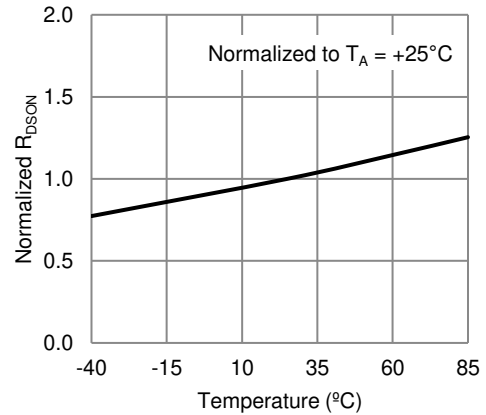

Typical Characteristics

$V_{IN}/V_{OUT} = 5V$, $C_{IN} = 1\mu F$, $C_{OUT} = 10\mu F$, \overline{WRX} floating (high), \overline{FLAG} floating (high), \overline{EN} floating (low), $VP = GND$ (17V V_{OVP}), Temp = 25°C unless otherwise specified.

Normalized OVP Threshold vs. Temperature

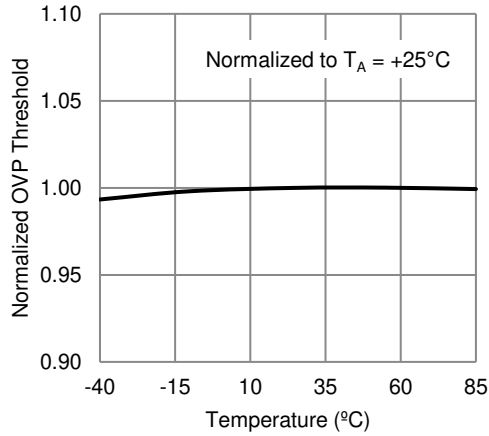

VSNS Clamp Voltage vs. VIN

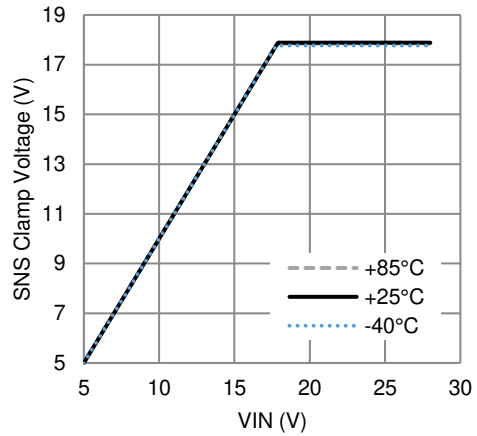

Normalized Debounce Time vs. Temperature

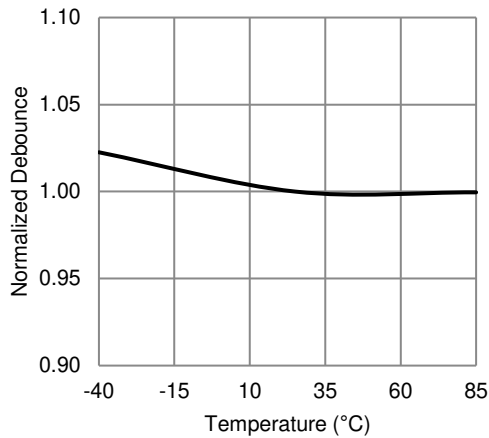

Typical Characteristics (continued)

$V_{IN}/V_{OUT} = 5V$, $C_{IN} = 1\mu F$, $C_{OUT} = 10\mu F$, \overline{EN} floating (low), VP floating (13V V_{OVP}), Temp = 25°C unless otherwise specified.

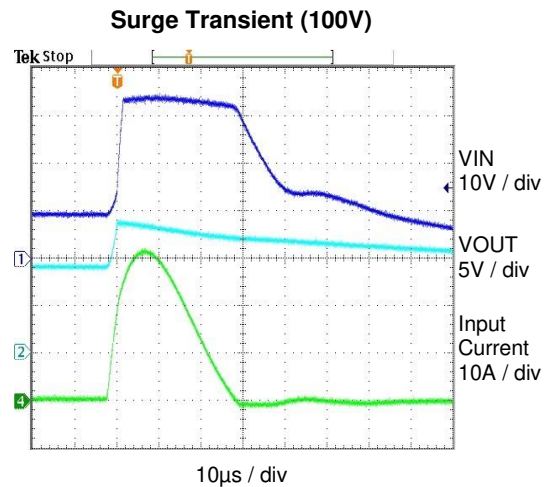
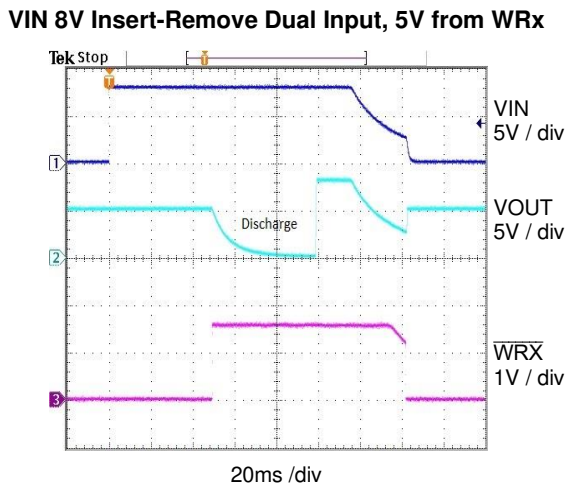
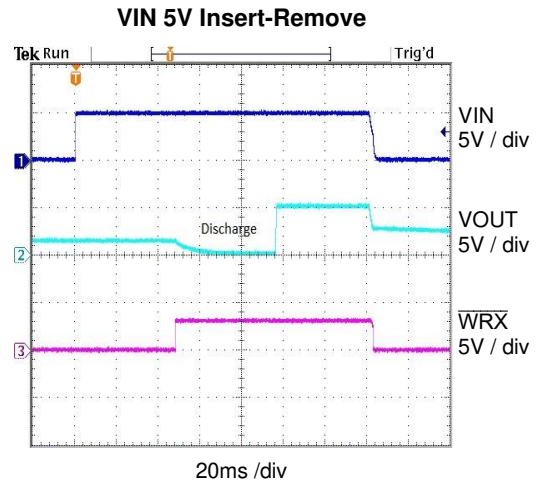
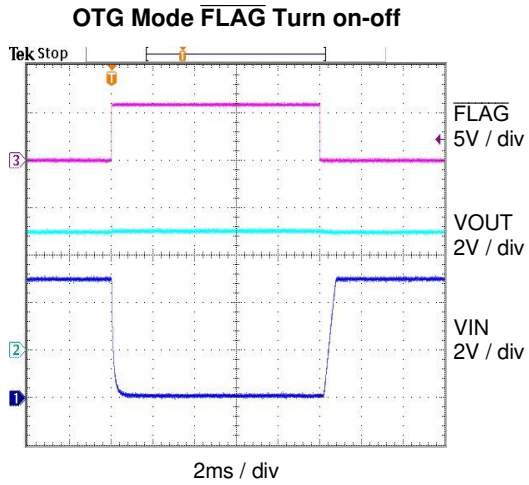

Functional Block Diagram

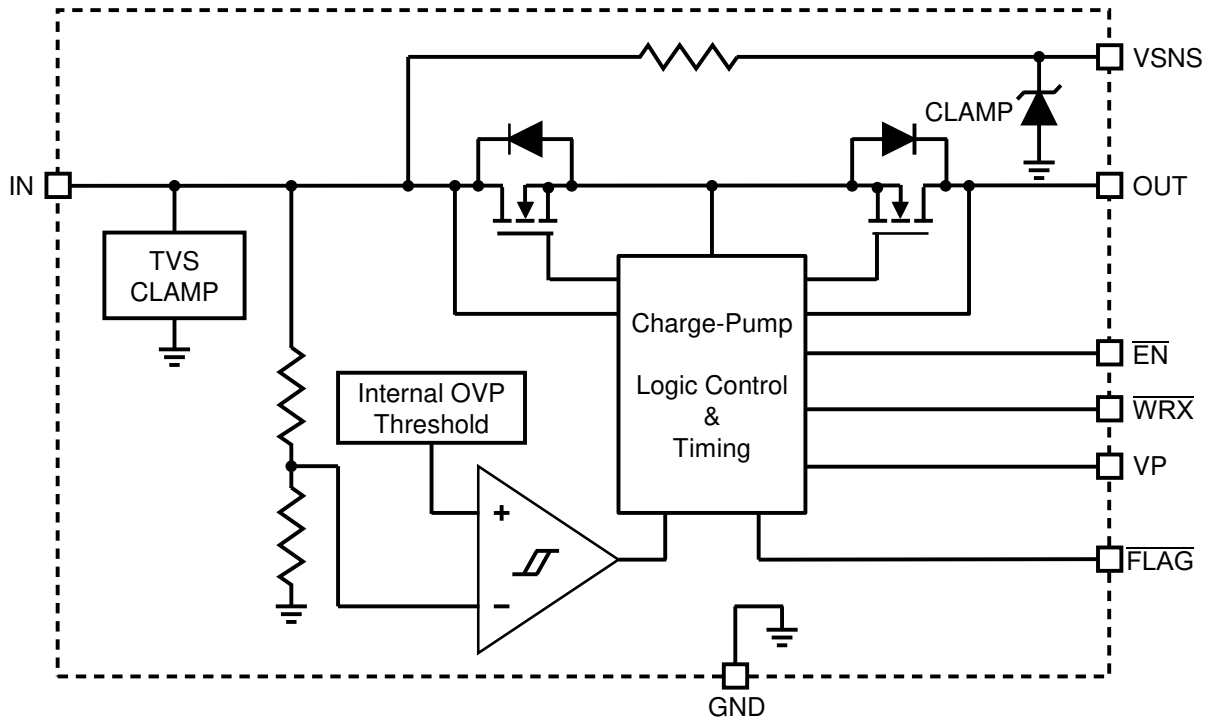

Functional Description

The KTS1676 is inserted between the power supply or charger source and the load to be protected. The KTS1676 consists of two “back-to-back” low resistance OVP MOSFET switches, under-voltage lockout protection (UVLO), over-voltage monitor and protection (OVLO), and power good output flags.

The KTS1676 overvoltage protection device features low on-resistance ($R_{DS(on)}$) internal FETs and protects low-voltage systems against voltage faults up to +28VDC. An internal clamp also protects the device from surges up to +100V. If the input voltage exceeds the overvoltage threshold, the internal FETs are turned off to prevent damage to the protected components. A 50ms debounce time built into the device prevents false turn on of the internal FET during startup. The KTS1676 also supports OTG mode where both MOSFETs can be turned-on to provide current flow from OUT to IN. With OTG mode de-asserted and the switch turned off, the KTS1676 blocks any voltage at OUT appearing at IN.

The KTS1676 features a VP selector pin, which gives the user two OVP/VSNS voltage options. Connecting VP to ground, selects an OVP of typically 17V and a maximum VSNS clamp voltage of 20V and when the VP is left to “FLOAT” selects and OVP of typically 13V and a maximum VSNS clamp voltage of 16V.

Dual Input Device Operation

The addition of a wireless receiver (WRx) with an enable pin allows KTS1676 load switch to implement an equivalent 2:1 power multiplexer (PMUX), see Figure 1. When disabled, the wireless receiver withstand voltage must be greater than or equal to 20V which is the load switch maximum input operating voltage.

The load switch can transition between OFF state and OTG modes based on the input state (IN adapter and/or WRx). When the charger detects an OTG plug-in event, the transition to OTG mode is possible.

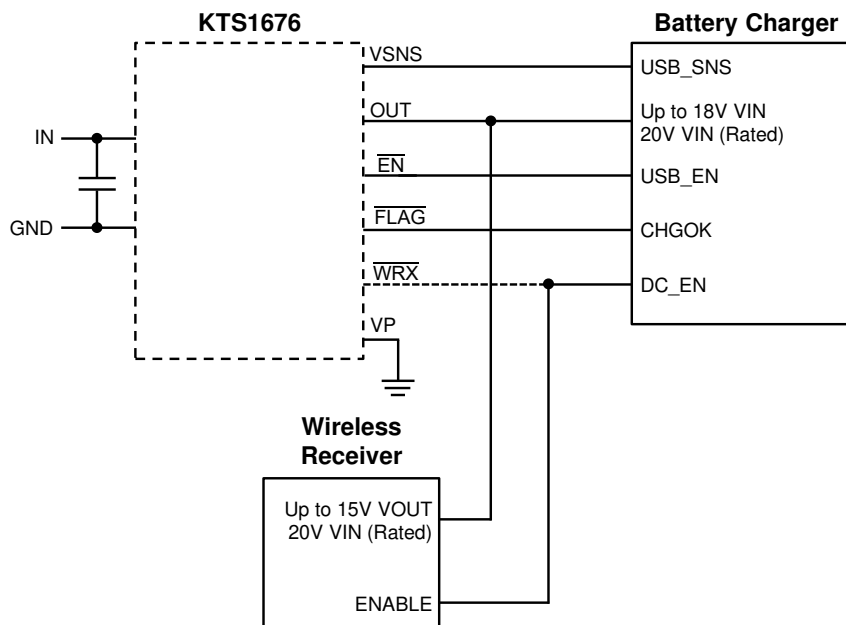

Figure 1. Dual Input Device Operation

PMUX Operation Modes

The 2:1 PMUX can operate in Slave and/or Autonomous modes. Slave mode allows the system (battery charger) to act as master and determine the input priority, while Autonomous mode assigns input priority to the IN power source over the wireless receiver.

Both slave and autonomous include a 50ms input debounce and 0.5ms soft-start times.

Autonomous mode includes a 50ms automatic break-before-make plus discharge period that is disabled in slave mode by grounding \overline{WRX} pin.

Note. Concurrent mode requires slave mode.

Slave Mode

In Slave mode, both \overline{FLAG} and \overline{WRX} pins are tied to GND. The system (battery charger) acts as master and disables the wireless receiver and activates the load switch On-State via the \overline{EN} pin. Slave mode allows the system (charger) to assign the priority of the input power source when both power sources are active.

- System (charger) controls input/wireless priority
- System interface with a valid IN/OUT:
 - Toggling \overline{EN} = high triggers the standby-state, ON-state, or ON-state/OTG mode
 - The wireless receiver may be enabled by the charger (System)
- OTG slave mode: A low input voltage threshold is detected at the IN pin.

Toggling \overline{EN} = low triggers OTG mode, the wireless receiver may be enabled by the charger (system) as follows:

- The system (charger) that controls OTG concurrent mode requires that the master enables the boost and/or wireless receiver. OTG mode is triggered when the master detects that the necessary conditions are met.

Autonomous Mode

In Autonomous mode, the \overline{EN} pin is tied to GND. The load switch controller activates the load switch ON-State after a fixed time delay when a valid VSNS voltage is detected. Autonomous mode gives priority to the IN input.

- The load-switch controls input/wireless priority.
- System interface with valid IN/OUT.
- OTG autonomous mode: A low-input voltage threshold is detected at VSNS.
 - Toggling \overline{FLAG} = low triggers OTG mode since \overline{EN} = GND, after \overline{WRX} = high disables the wireless receiver.

Input Surge Protection

The device must withstand up to 100V surge voltage applied from the IN pin to ground pin. The surge may be applied to the load switch in the on or off states. The surge waveform is compatible with the IEC 61000-4-5 specification, $R_{SOURCE} = 2.0\Omega$, 1.2/50 μ s waveform.

Over-voltage Protection

In normal operation, the OVP switch acts as a slew-rate controlled load switch, connecting and disconnecting the power supply from IN to OUT.

When the voltage on the input exceeds the selected programmed over-voltage trip point, the device immediately turns off the internal OVP switch, disconnecting the load from the abnormal voltage, preventing damage to any downstream components.

The OVP trip point can be selected by the VP pin. Connecting to GND gives a typical 17V trip point and allowing VP to float, typical 13V.

Soft-start

In-rush current is minimized by a soft-start (t_{SS}) which occurs during activation of the load switch. Soft start occurs when the switch is enabled, either in slave mode or autonomous mode.

OTG Modes

OTG modes occur after the charger detects an OTG plug-in event, around 5V is applied to the OUT pin, and the IN pin is tied to an OTG load. The VSNS and EN pins are used in slave mode, while the FLAG pin is used in autonomous mode as shown in Figure 2.

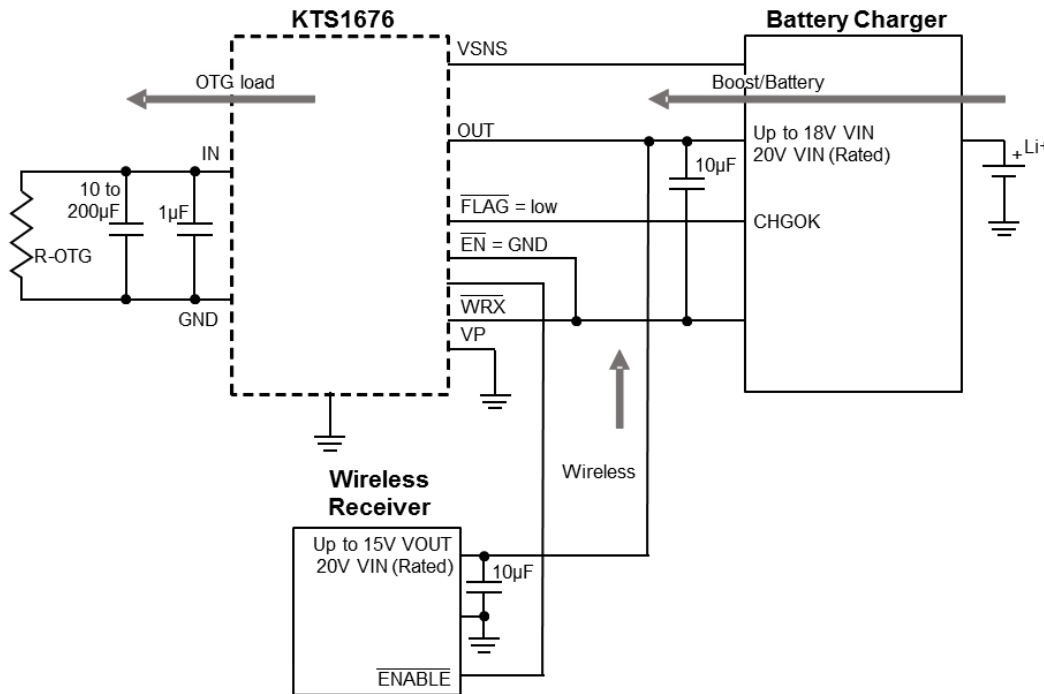

Figure 2. OTG Mode (R-OTG Load Applied to IN, Autonomous Mode)

OTG mode must support $C_{IN} = 1\mu F$ (static), plus capacitive load $C_{OTG} = 200\mu F$ that can occur during a hot plug event, as shown in Figure 3.

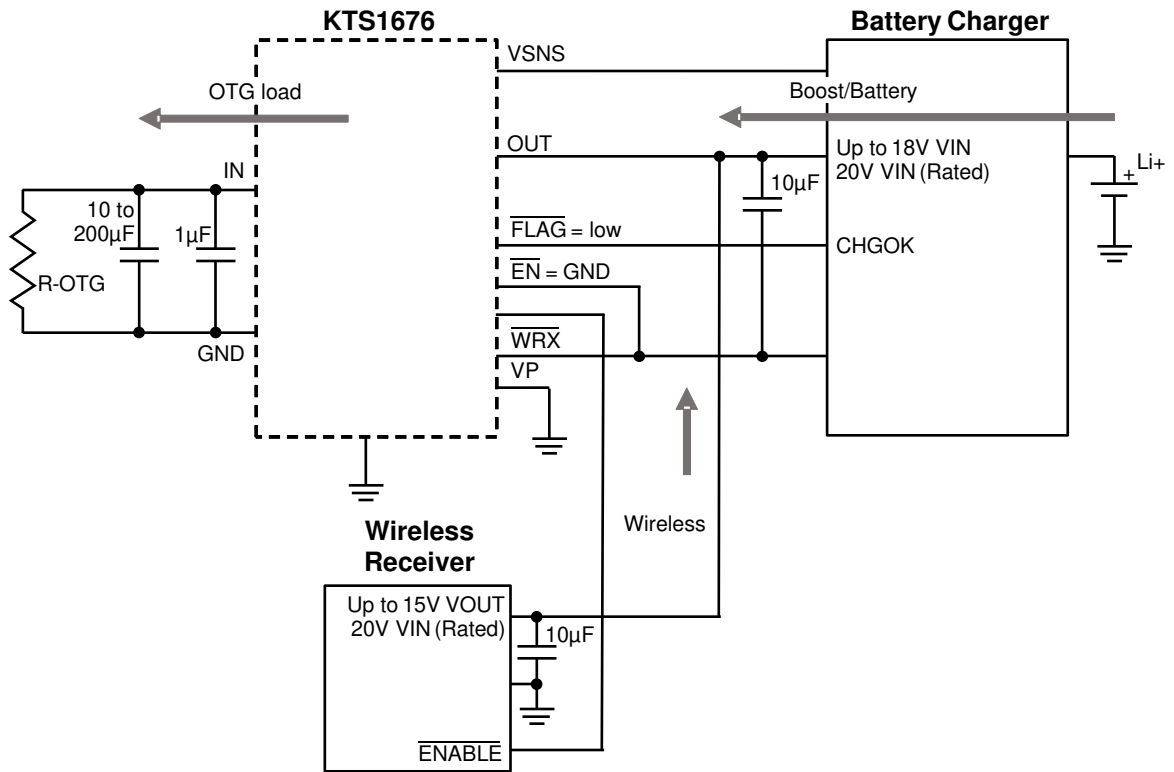

Figure 3. OTG Cable Capacitive Load Hot Plug Event

Timing Diagrams

Figure 4 through Figure 7 show slave and autonomous mode timing diagrams.

In slave mode ($\overline{\text{FLAG}}$ and $\overline{\text{WRX}}$ pins are tied to GND), the on/off state of the load switch is determined by the EN logic input pin that is tied to the system logic.

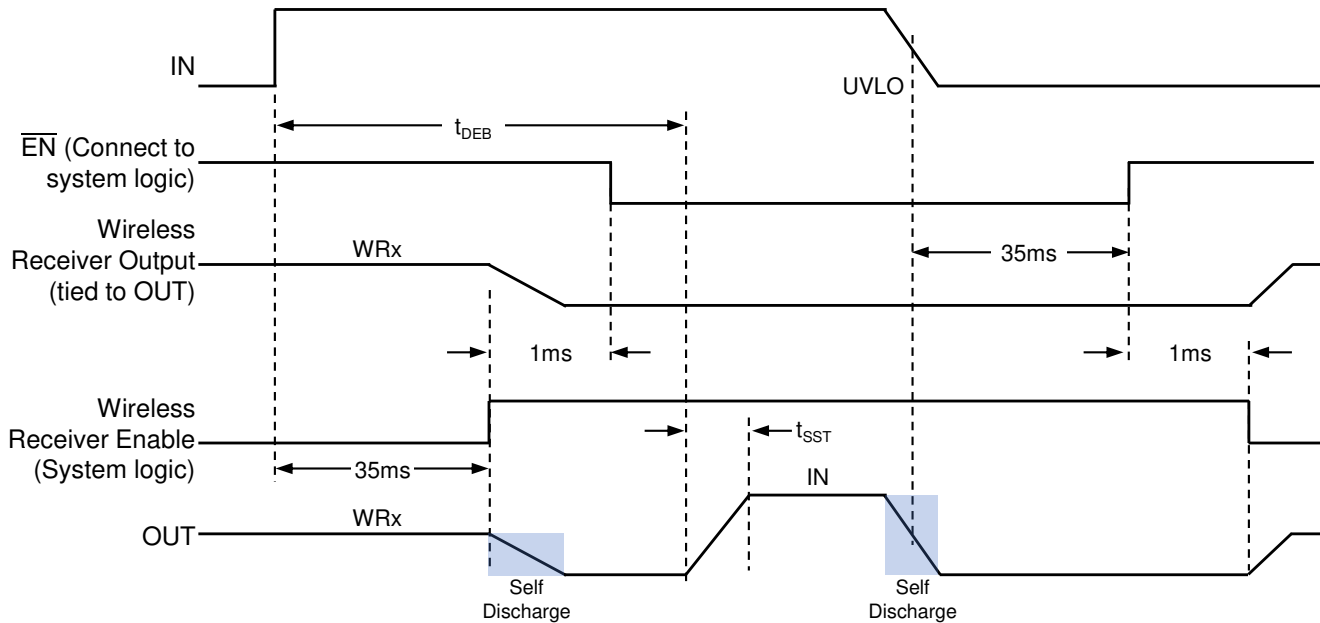

Figure 4. Slave Mode Timing (with battery present): Dual Input with IN Insertion and Removal

In autonomous mode ($\overline{\text{EN}} = \text{GND}$), a 50ms debounce time followed by 50ms discharge time, and t_{SST} soft-start delay are applied when the IN input rising and falling thresholds are detected. The FLAG pin provides the IN pin voltage status.

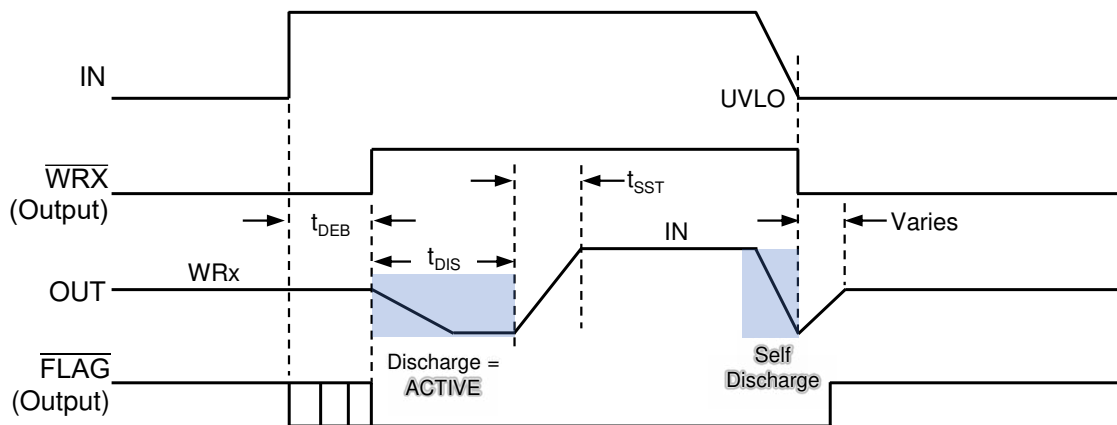

Figure 5. Autonomous Mode Timing: Dual Input with IN Insertion and Removal ($\overline{\text{EN}} = \text{low}$)

In OTG modes, a load is applied to IN pin and current flows from OUT to IN. After a valid OUT voltage is applied after a debounce time and no voltage is detected at IN, the FLAG serves as a logic output and toggles high. The FLAG pin is bidirectional, and autonomous OTG modes are triggered by pulling the FLAG input pin low.

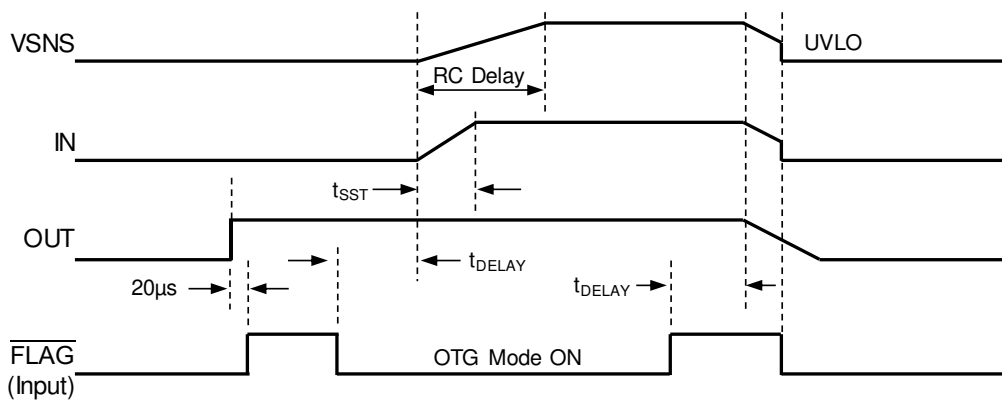

Figure 6. Autonomous OTG Mode Timing: OTG Insertion and Removal (\overline{EN} = low)

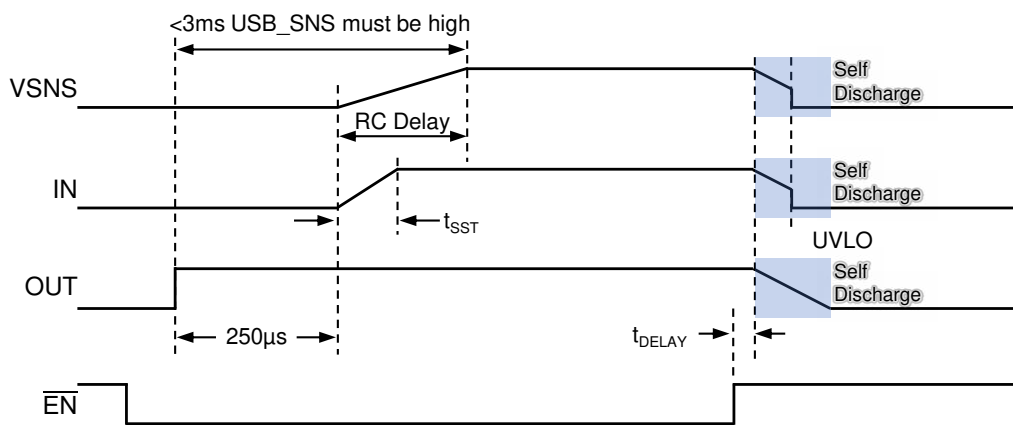

Figure 7. Slave OTG mode timing: OTG Activate and Deactivate (\overline{FLAG} = low, \overline{WRX} = low)

Bidirectional Blocking

The KTS1676 features bidirectional blocking. When IN pin voltage is below the input start-up voltage and \overline{FLAG} is high (OTG mode disabled), the switch between IN and OUT is open and the internal diodes of the two MOSFET switches are back-to-back, thereby blocking any reverse current. This is also true when the device is in OVP mode.

\overline{FLAG} logic

The \overline{FLAG} pin is a bidirectional input/output pin that controls the transition to and from OTG modes while in autonomous mode.

When IN is disconnected (floating) and a valid OUT voltage is detected, the \overline{FLAG} pin serves as an output signal and \overline{FLAG} = logic high. Subsequently, the load switch can be activated by toggling the \overline{FLAG} = logic low, which triggers OTG mode by transitioning into the ON-state.

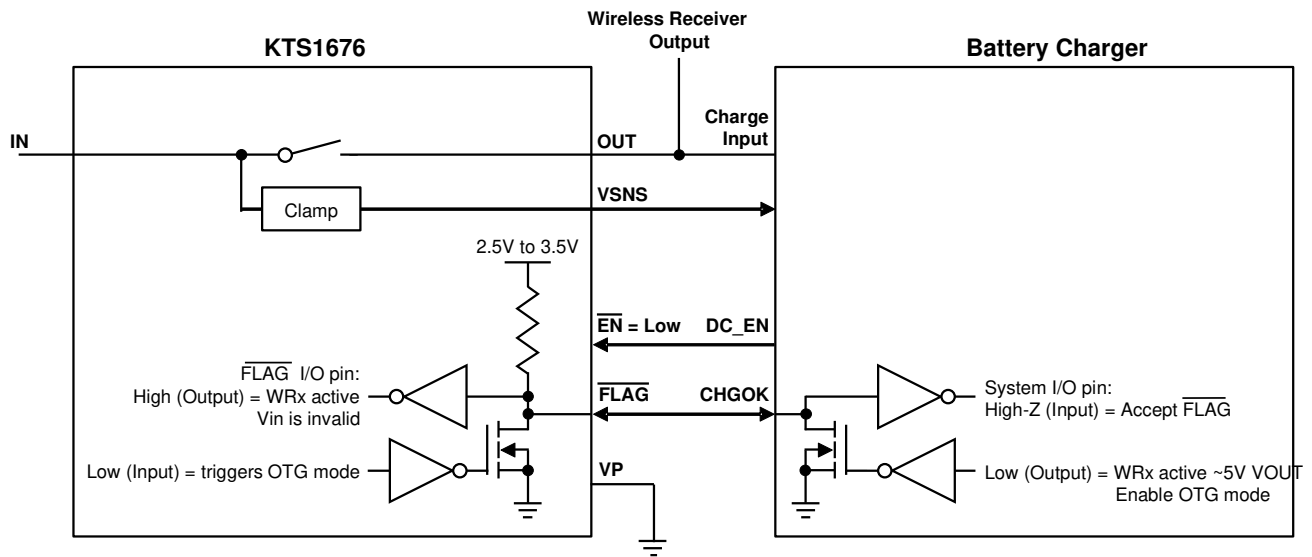

IN	OUT	FLAG	CHGOK	Load - Switch Behavior ($\overline{EN} = \text{Low}$)
< VUVLO	>VUVLO	High	Hi-Z	Load switch = OFF and OTG mode can be enabled On/off state of WRx determined by battery charger
= VOUT	= VOUT	Low	Low	Load switch = ON, OTG mode(s) enabled On/off state of WRx determined by battery charger
>VUVLO	Low	Low	X	Load switch = ON ($\overline{EN} = \text{Low}$), OTG mode not allowed

Figure 8. FLAG Logic

Thermal Protection

The KTS1676 features thermal shutdown to prevent the device from overheating. The internal FETs turn off when the junction temperature exceeds +150°C (typ). The device exits thermal shutdown after the junction temperature cools by 15°C (typ) hysteresis.

Logic State Diagram: Autonomous Mode ($\overline{EN} = \text{low}$)

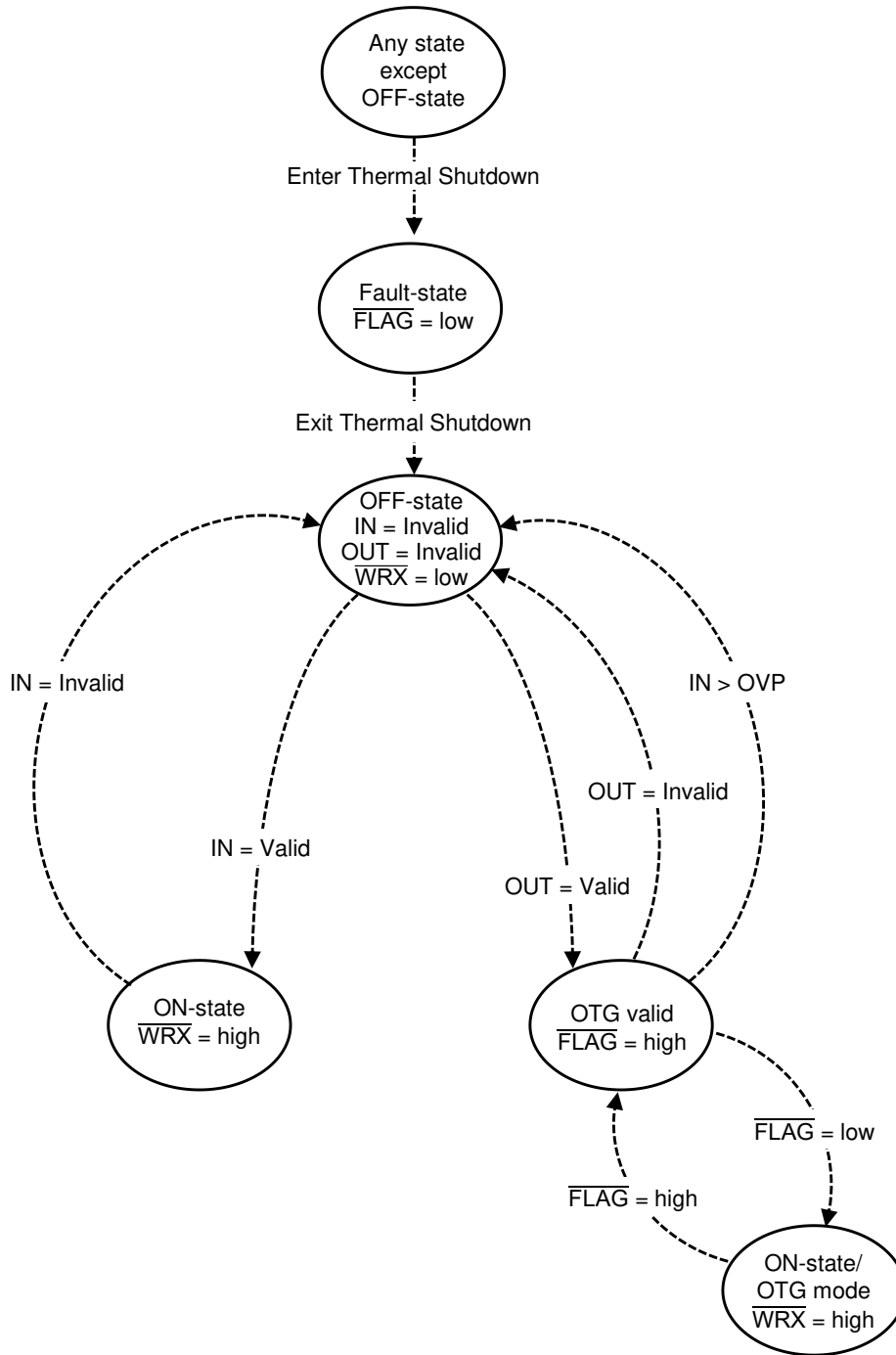

Figure 9. Logic State Diagram, Autonomous Mode

Logic State Diagram: Slave Mode ($\overline{\text{FLAG}} = \text{low}$ & $\overline{\text{WRX}} = \text{low}$)

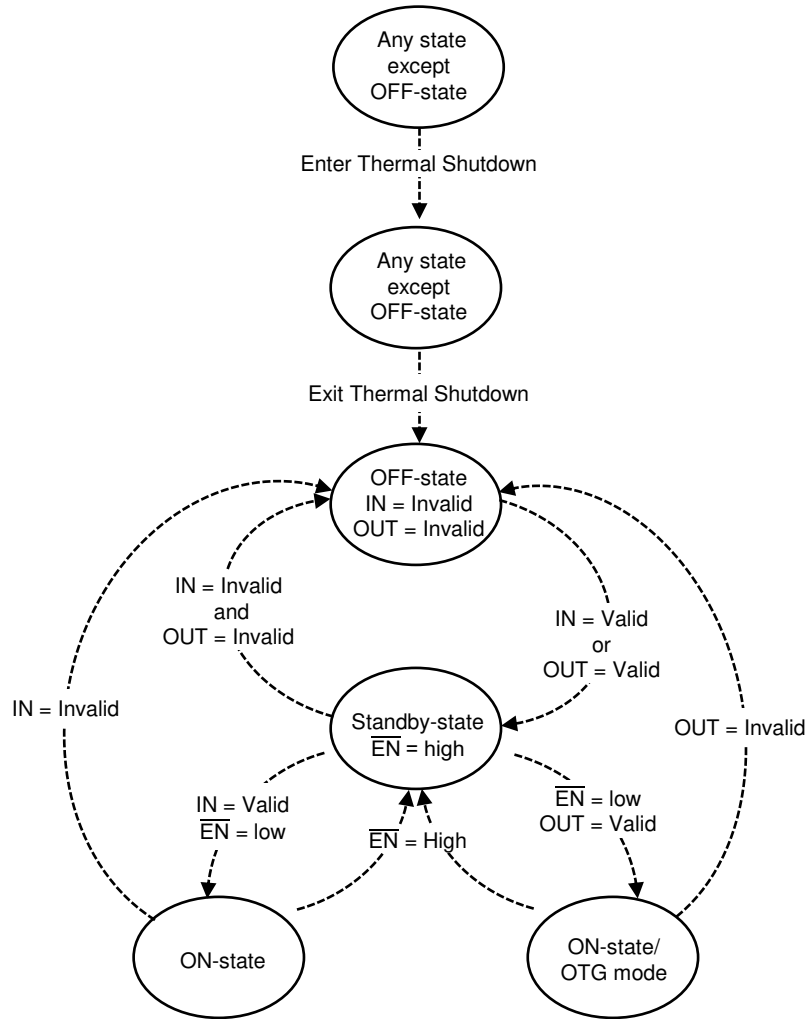

Figure 10. Logic State Diagram, Slave Mode

Applications Information

Input Capacitor

A 1 μ F or larger capacitor is typically recommended for C_{IN}. C_{IN} should be located as close to the device IN pin as practically possible. 50V rated capacitors are generally good for most OVP applications to support any surge transient voltage.

Output Capacitor

The soft-start function provides a slow turn-on that allows the KTS1676 to charge large output capacitors with minimum in-rush current. It is recommended to bypass OUT with a 1 μ F minimum ceramic capacitor.

ESD Test Conditions and Human Body Model ESD Protection

The KTS1676 fully supports the IEC61000-4-2, (Input pin, 1 μ F mounted on board). In Air condition, V_{IN} has a \pm 15kV ESD protected input. In Contact condition and air-gap condition, V_{IN} has \pm 8kV ESD protected input.

Recommended PCB Layout

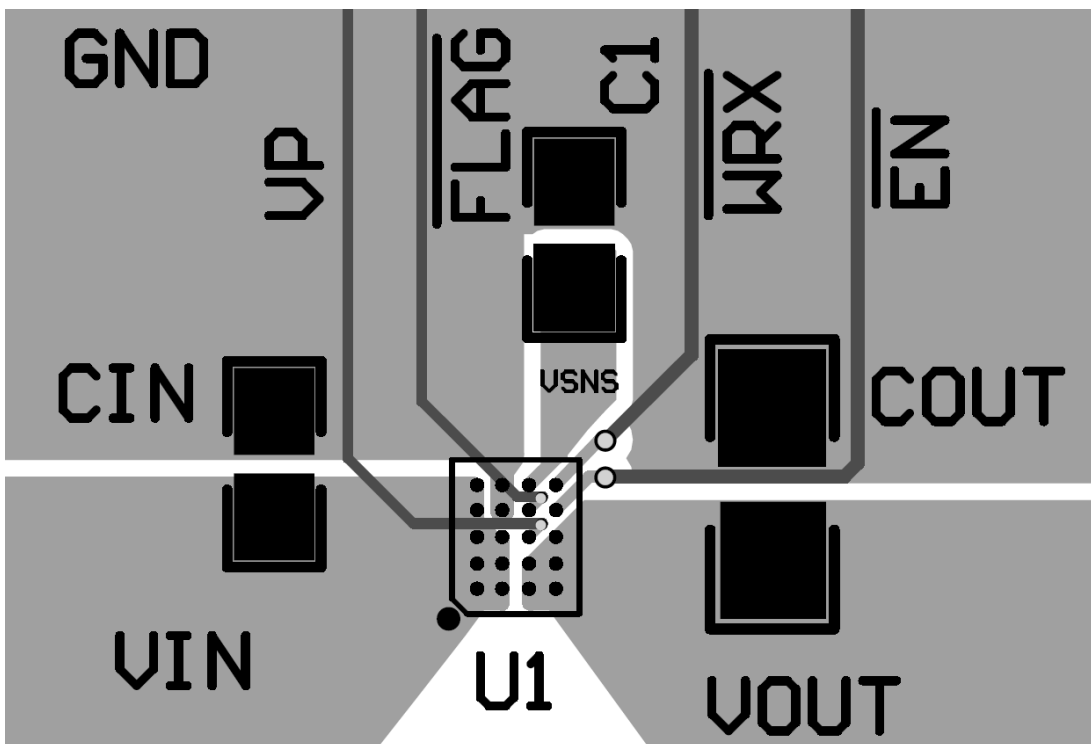
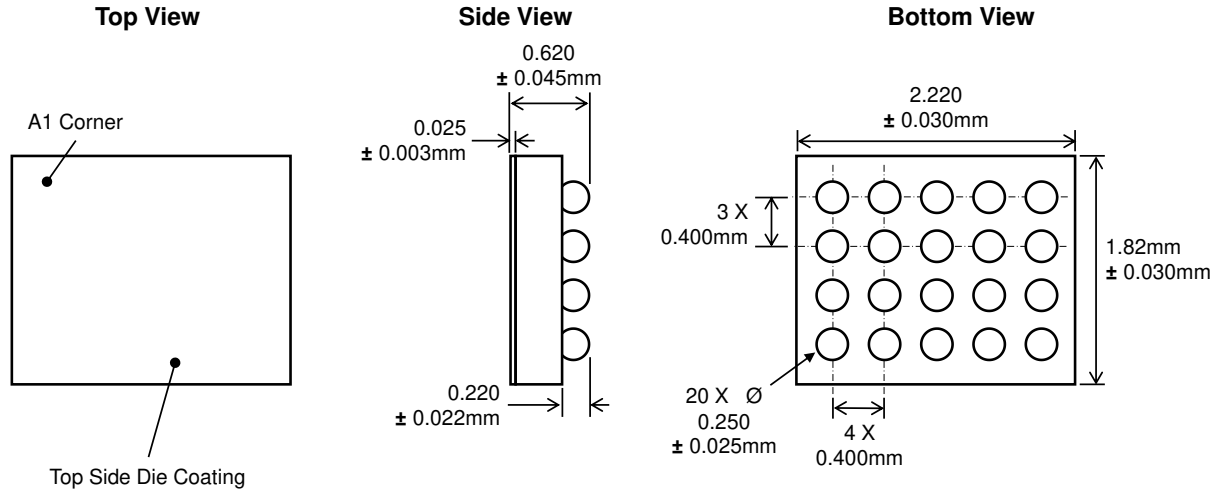

Figure 11. Recommended PCB Layout

Packaging Information

WLCSP54-20, 2.22mm x 1.82mm x 0.62mm



Recommended Footprint

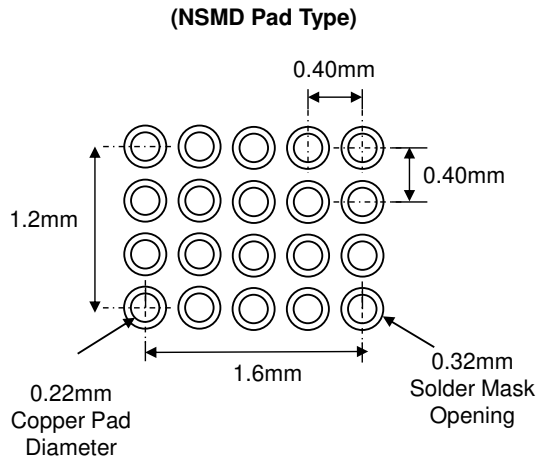

* Dimensions are in millimeters.

Kinetic Technologies cannot assume responsibility for use of any circuitry other than circuitry entirely embodied in a Kinetic Technologies product. No intellectual property or circuit patent licenses are implied. Kinetic Technologies reserves the right to change the circuitry and specifications without notice at any time.