

SMD Zener Diode

CZRB3005-G Thru. CZRB3200-G

Voltage: 6.2 to 200 Volts

Power: 3 Watts

RoHS Device

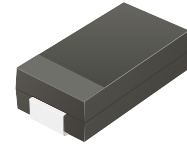

Features

- Glass passivated chip
- Low leakage
- Built-in strain relief
- Low inductance
- High peak reverse power dissipation
- For use in stabilizing and clipping circuits with high power rating

Mechanical data

- Epoxy: UL 94V-0 rate flame retardant.
- Case: DO-214AA(SMB), Molded plastic.
- Lead: Solderable per MIL-STD-750, method 2026.
- Polarity: Color band denotes cathode end.
- Mounting position: Any.
- Weight: 0.1 grams approx.

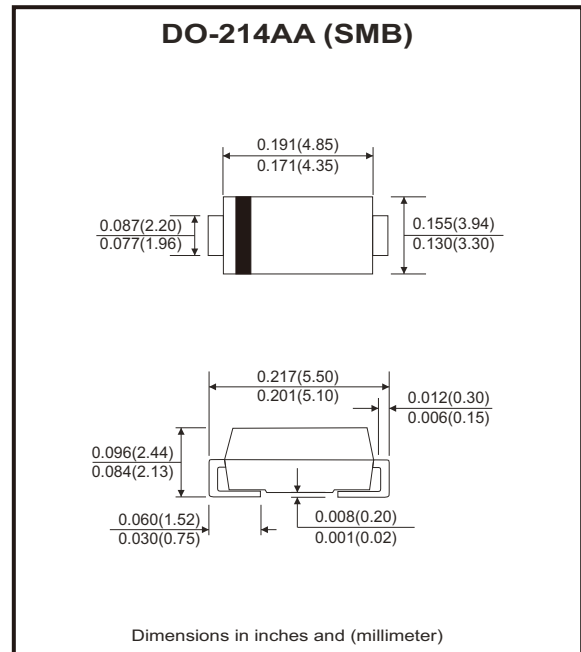

Circuit diagram



Maximum Ratings (T_A=25°C unless otherwise noted)

Parameter	Symbol	Value	Unit
Maximum forward voltage at I _F = 200 mA	V _F	1.5	V
DC Power dissipation at T _L = 50°C (Note 1)	P _D	3	W
Junction temperature range	T _J	-55 to +150	°C
Storage temperature range	T _{STG}	-55 to +150	°C

Note: 1. Mounted on 5.0mm² (1 oz thick) land areas, lead temperature at T_L=50°C.

Electrical Characteristics (TA=25°C unless otherwise noted)

Part Number	Nominal Zener Voltage		Maximum Zener Impedance			Maximum Reverse Leakage Current		Maximum DC Zener Current	Marking Code
	Vz @ IZT	IZT	ZzT @ IZT	Zzk @ Izk	Izk	IR @ VR		IZM	
	(V)	(mA)	(Ohm)	(Ohm)	(mA)	(µA)	(V)	(mA)	
CZRB3005-G	6.2	121.0	1.5	700	1.0	5.0	3.0	435	3A0
CZRB3006-G	6.8	110.0	2.0	700	1.0	5.0	4.0	393	3A1
CZRB3007-G	7.5	100.0	2.0	700	0.5	5.0	5.0	360	3A2
CZRB3008-G	8.2	91.0	2.3	700	0.5	5.0	6.0	330	3A3
CZRB3009-G	9.1	82.0	2.5	700	0.5	3.0	7.0	297	3A4
CZRB3010-G	10.0	75.0	3.5	700	0.25	3.0	7.6	270	3A5
CZRB3011-G	11.0	68.0	4.0	700	0.25	1.0	8.4	225	3A6
CZRB3012-G	12.0	63.0	4.5	700	0.25	1.0	9.1	246	3A7
CZRB3013-G	13.0	58.0	4.5	700	0.25	0.5	9.9	208	3A8
CZRB3014-G	14.0	53.0	5.0	700	0.25	0.5	10.6	193	3A9
CZRB3015-G	15.0	50.0	5.5	700	0.25	0.5	11.4	180	3B0
CZRB3016-G	16.0	47.0	5.5	700	0.25	0.5	12.2	169	3B1
CZRB3017-G	17.0	44.0	6.0	750	0.25	0.5	13.0	159	3B2
CZRB3018-G	18.0	42.0	6.0	750	0.25	0.5	13.7	150	3B3
CZRB3019-G	19.0	40.0	7.0	750	0.25	0.5	14.4	142	3B4
CZRB3020-G	20.0	37.0	7.0	750	0.25	0.5	15.2	135	3B5
CZRB3022-G	22.0	34.0	8.0	750	0.25	0.5	16.7	123	3B6
CZRB3024-G	24.0	31.0	9.0	750	0.25	0.5	18.2	112	3B7
CZRB3027-G	27.0	28.0	10.0	750	0.25	0.5	20.6	100	3B8
CZRB3028-G	28.0	27.0	12.0	750	0.25	0.5	21.0	96	3B9
CZRB3030-G	30.0	25.0	16.0	1000	0.25	0.5	22.5	90	3C0
CZRB3033-G	33.0	23.0	20.0	1000	0.25	0.5	25.1	82	3C1
CZRB3036-G	36.0	21.0	22.0	1000	0.25	0.5	27.4	75	3C2
CZRB3039-G	39.0	19.0	28.0	1000	0.25	0.5	29.7	69	3C3
CZRB3043-G	43.0	17.0	33.0	1500	0.25	0.5	32.7	63	3C4
CZRB3047-G	47.0	16.0	38.0	1500	0.25	0.5	35.6	57	3C5
CZRB3051-G	51.0	15.0	45.0	1500	0.25	0.5	38.8	53	3C6
CZRB3056-G	56.0	13.0	50.0	2000	0.25	0.5	42.6	48	3C7
CZRB3062-G	62.0	12.0	55.0	2000	0.25	0.5	47.1	44	3C8
CZRB3068-G	68.0	11.0	70.0	2000	0.25	0.5	51.7	40	3C9
CZRB3075-G	75.0	10.0	85.0	2000	0.25	0.5	56.0	36	3F0
CZRB3082-G	82.0	9.1	95.0	3000	0.25	0.5	62.2	33	3F1
CZRB3091-G	91.0	8.2	115.0	3000	0.25	0.5	69.2	30	3F2
CZRB3100-G	100.0	7.5	160.0	3000	0.25	0.5	76.0	27	3F3

Notes: 1. The type number listed have a standard tolerance on the nominal zener voltage of $\pm 5\%$.
 2. The reverse surge current is a non-repetitive, 8.3ms pulse width square wave or equivalent sine-wave superimposed on IZT per JEDEC Method.

Electrical Characteristics (TA=25°C unless otherwise noted)

Part Number	Nominal Zener Voltage		Maximum Zener Impedance			Maximum Reverse Leakage Current		Maximum DC Zener Current	Marking Code
	Vz @ IZT	IZT	ZzT @ IZT	ZzK @ IZK	IZK	IR @ VR		IZM	
	(V)	(mA)	(Ohm)	(Ohm)	(mA)	(µA)	(V)	(mA)	
CZRB3110-G	110.0	6.8	225.0	4000	0.25	0.5	83.6	25	3F4
CZRB3120-G	120.0	6.3	300.0	4500	0.25	0.5	91.2	22	3F5
CZRB3130-G	130.0	5.8	375.0	5000	0.25	0.5	98.8	21	3F6
CZRB3140-G	140.0	5.3	475.0	5000	0.25	0.5	106.4	19	3F7
CZRB3150-G	150.0	5.0	550.0	6000	0.25	0.5	114.0	18	3F8
CZRB3160-G	160.0	4.7	625.0	6500	0.25	0.5	121.6	17	3F9
CZRB3170-G	170.0	4.4	650.0	7000	0.25	0.5	130.4	16	3G1
CZRB3180-G	180.0	4.2	700.0	7000	0.25	0.5	136.8	15	3G2
CZRB3190-G	190.0	4.0	800.0	8000	0.25	0.5	144.8	14	3G3
CZRB3200-G	200.0	3.7	875.0	8000	0.25	0.5	152.0	13	3G4

Notes: 1. The type number listed have a standard tolerance on the nominal zener voltage of $\pm 5\%$.
 2. The reverse surge current is a non-repetitive, 8.3ms pulse width square wave or equivalent sine-wave superimposed on IZT per JEDEC Method.

Rating and Characteristic Curves (CZRB3005-G Thru. CZRB3200B-G)

Fig.1 - Power Temperature Derating Current

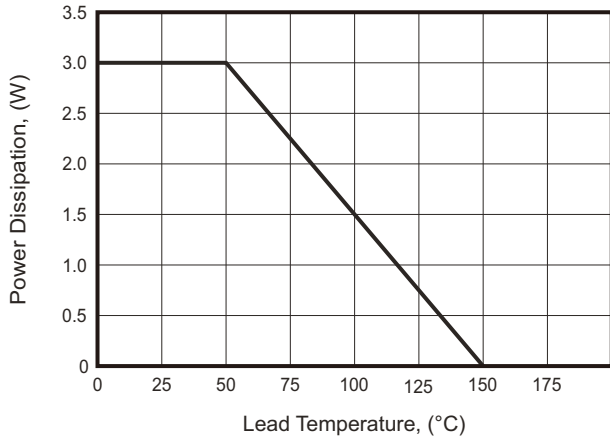

Fig.2 - Temperature Coefficients v.s. Zener Voltage

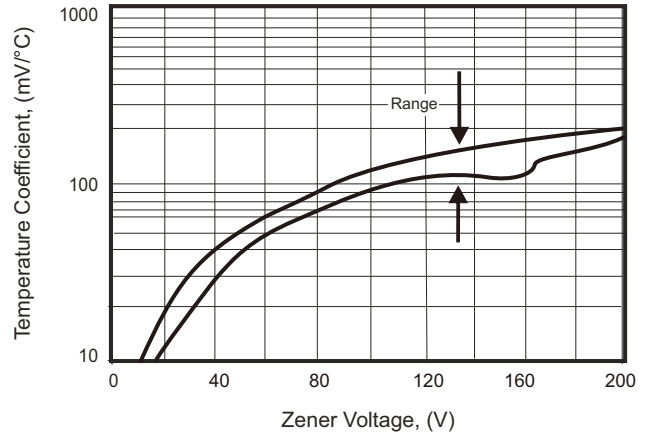

Fig.3 - Typical Thermal Resistance v.s. Lead Length

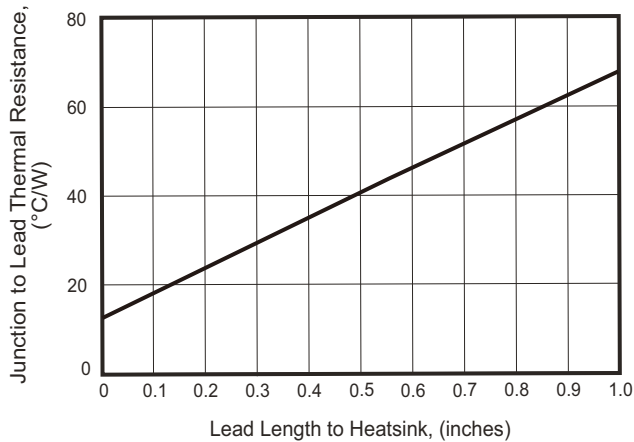
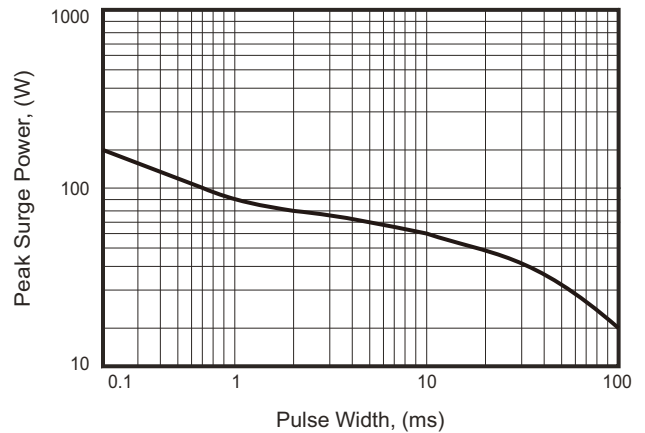
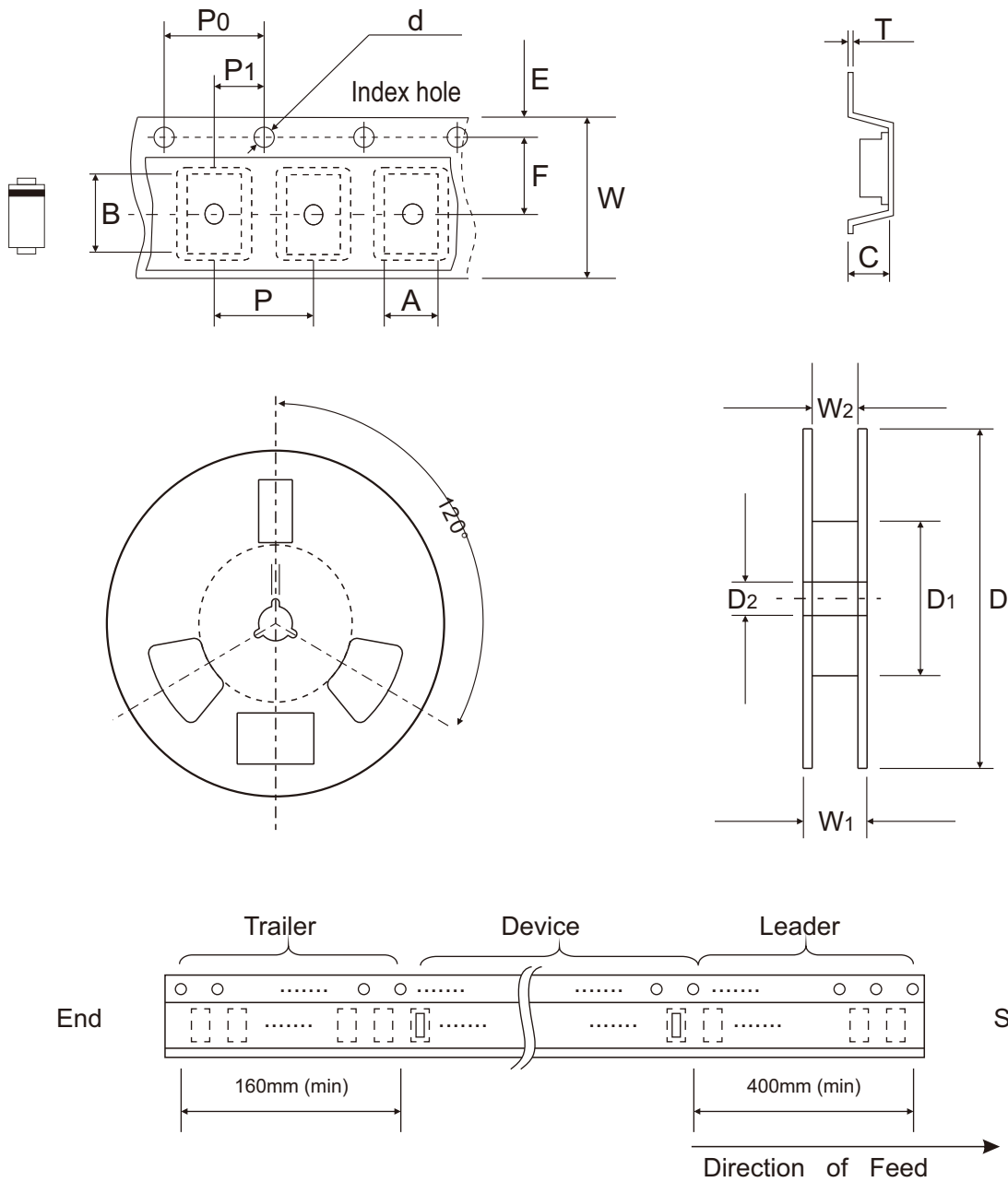

Fig.4 - Maximum Surge Power



Reel Taping Specification



DO-214AA (SMB)	SYMBOL	A	B	C	d	D	D1	D2	E
	(mm)	See Note 1			1.55 ± 0.05	330.00	50.00 (Min.)	13.00 + 0.50 - 0.20	1.75 ± 0.10
	(inch)	See Note 1			0.061 ± 0.002	12.992	1.969 (Min.)	0.512 + 0.020 - 0.008	0.069 ± 0.004

DO-214AA (SMB)	SYMBOL	F	P	P0	P1	T	W	W1	W2
	(mm)	5.50 ± 0.05	8.00 ± 0.10	4.00 ± 0.10	2.00 ± 0.05	0.40 (Max.)	12.00 ± 0.10	18.40 (Max.)	12.40 + 2.00 - 0.00
	(inch)	0.217 ± 0.002	0.315 ± 0.004	0.157 ± 0.004	0.079 ± 0.002	0.016 (Max.)	0.472 ± 0.004	0.724 (Max.)	0.488 + 0.079 - 0.000

Notes: 1. A, B, and C the clearance between the component and the cavity must be within 0.5mm max. for 8mm tape and 12mm tape, 1.0mm max. for 16mm tape and 24mm tape.

Company reserves the right to improve product design , functions and reliability without notice.

REV:C

Marking Code

Part Number	Marking Code
CZRB3005-G ~ CZRB3200-G	XXX



XXX = Marking code (see Page.2~3)

= Cathod Band

Suggested PAD Layout

SIZE	DO-214AA(SMB)	
	(mm)	(inch)
A	5.60 REF	0.220 REF
B	2.16 MAX	0.085 MAX
C	1.52 MIN	0.060 MIN
D	2.18 MIN	0.086 MIN

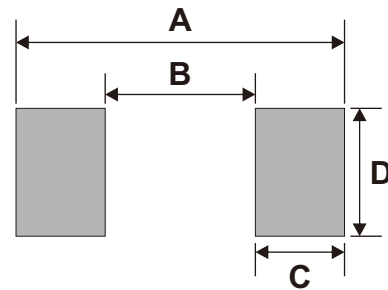

Standard Packaging

Case Type	REEL PACK	
	REEL (pcs)	Reel Size (inch)
DO-214AA (SMB)	3,000	13