



ANATECH ELECTRONICS INC
RF & Microwave Filters & Products

**1870-1885 MHz / 1950-1965 MHz
Cavity Duplexer**

Part Number: AE1877-1957DB40B



<u>Characteristics</u>	<u>Band 1</u>	<u>Band 2</u>
Passband:	1870-1885 MHz	1950-1965 MHz
Bandwidth:	15 MHz	15 MHz
Passband Insertion Loss:	≤ 1.0dB	≤ 1.0dB
Passband Return Loss:	≥ 18dB	≥ 18dB
Input / Output Impedance:	50 Ohms	50 Ohms
Isolation:	≥ 70 dB	≥ 70 dB

<u>Mechanical</u>	
Connector Type:	SMA (F)
Dimensions:	4.125x 2.0 x 2.0 inches.

<u>Environmental</u>	
Operating Temperature:	-40 to +70 deg.C
Storage Temperature:	-50 to +85 deg.C

Outline Drawing:

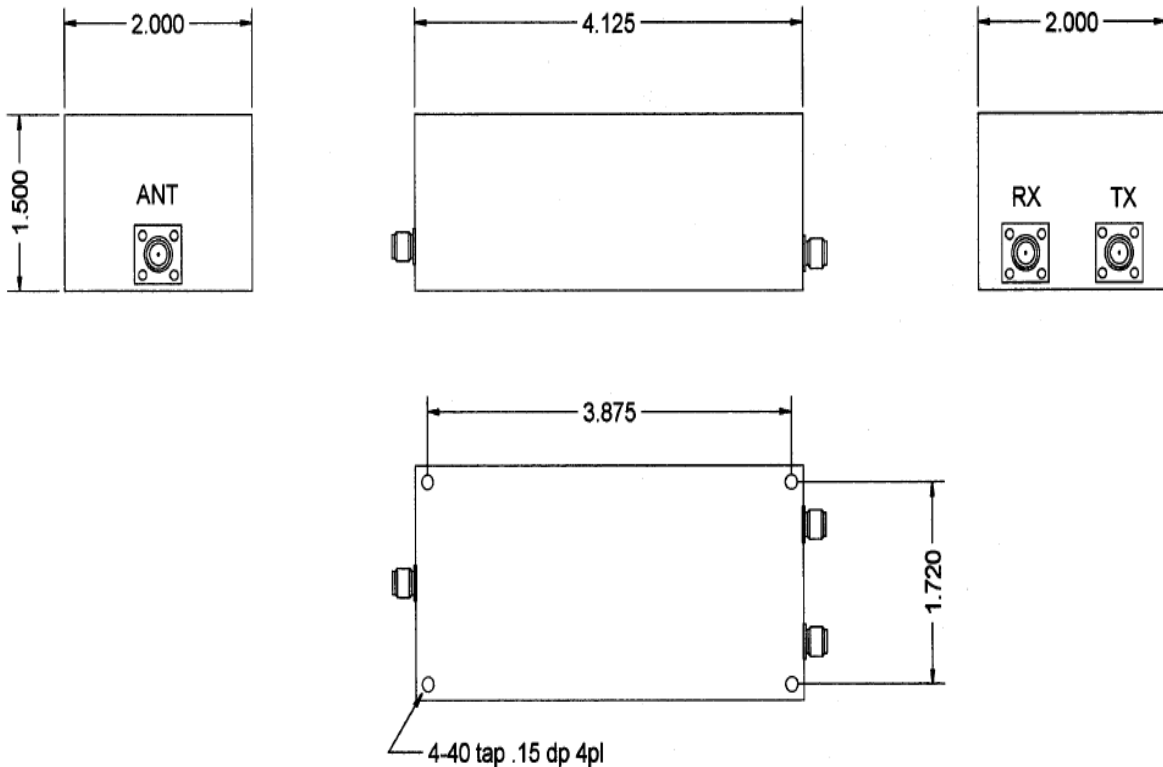



ANATECH ELECTRONICS INC
RF & Microwave Filters & Products

1870-1885 MHz / 1950-1965 MHz Cavity Duplexer

Part Number: AE1877-1957DB40B



Response Plot:

