

UNCONTROLLED DOCUMENT

CAUTION: PRESSURE SENSITIVE ASSEMBLY
AVOID APPLYING PRESSURE TO LED
DURING PANEL ASSEMBLY.

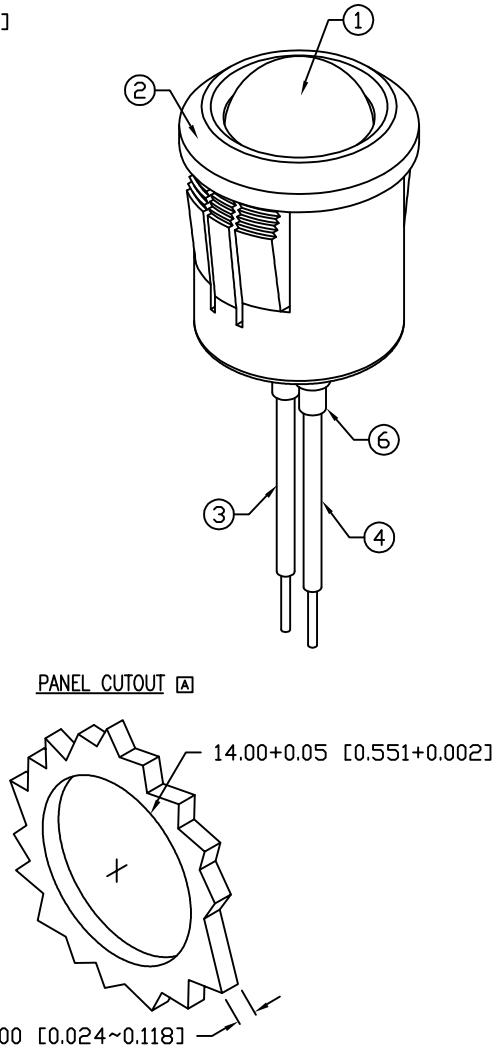
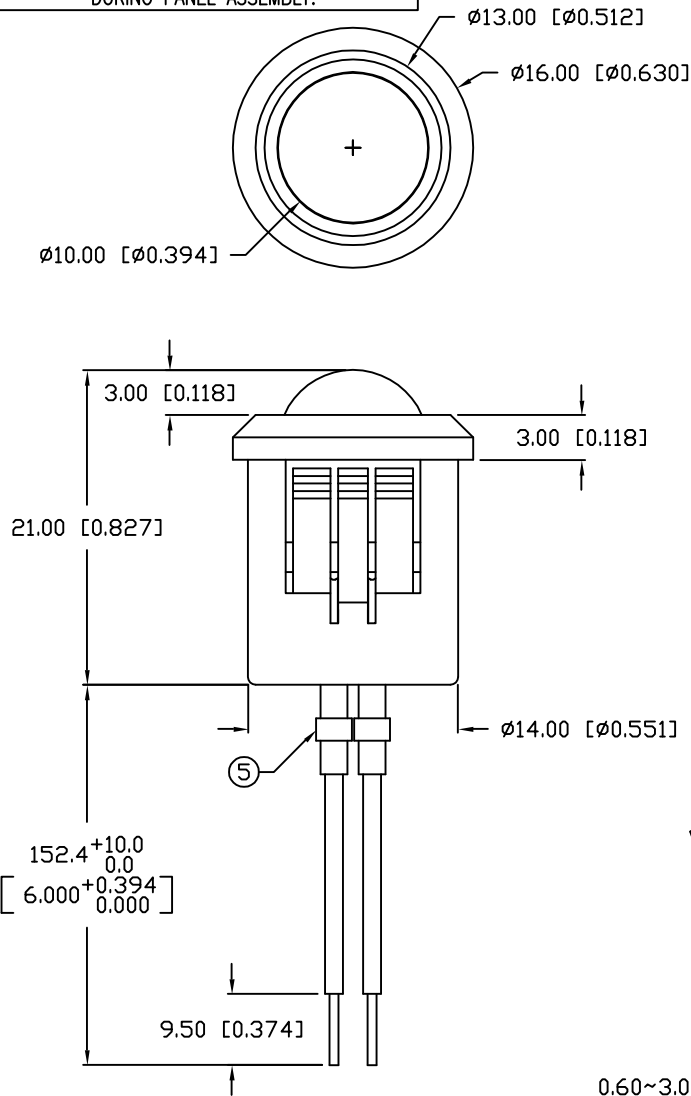

PART NUMBER
SSI-LXH1090SRD-150

REV.
C

REV.	E.C.N. NUMBER AND REVISION COMMENTS	DATE
A	E.C.N. #10539.	3.9.00
B	E.C.N. #10BRDR. & REDRAWN IN 3D.	1.5.02
C	E.C.N. #10BRDR. & REDRAWN IN 3D.	03.17.10

ELECTRO-OPTICAL CHARACTERISTICS $T_A=25^\circ\text{C}$ $I_f=20\text{mA}$

PARAMETER	MIN	TYP	MAX	UNITS	TEST COND
PEAK WAVELENGTH		660		nm	
FORWARD VOLTAGE		1.7	2.2	V_f	
REVERSE VOLTAGE	4.0			V_r	$I_f=100\mu\text{A}$
AXIAL INTENSITY		550		mcd	$I_f=20\text{mA}$
VIEWING ANGLE		60		2x theta	
EMITTED COLOR:	RED				
EPOXY LENS FINISH:	RED DIFFUSED				

LIMITS OF SAFE OPERATION AT 25°C

PARAMETER	MAX	UNITS
PEAK FORWARD CURRENT*	150	mA
STEADY CURRENT	30	mA
POWER DISSIPATION	75	mW
DERATE FROM 25°C	-1.2	$\text{mW}/^\circ\text{C}$
OPERATING, STORAGE TEMP.	-40 TO +85	$^\circ\text{C}$

* $t < 10\mu\text{s}$

NOTES:

1. SSL-LX100133SRD LED.
2. SSH-RTF1090 HOLDER.
3. ANODE LEAD: LXP-WST24RDT0C, 24 AWG STRANDED, RED INSULATION, CUT 144mm LONG, STRIP 3mm & 9.5mm.
4. CATHODE LEAD: LXP-WST24BLT0C, 24 AWG STRANDED, BLACK INSULATION, CUT 144mm LONG, STRIP 3mm & 9.5mm.
5. CRIMP WIRE LEADS TO LED LEADS.
6. 2 PIECES- 32mm, 1/16" BLACK HEAT SHRINK TUBING.
7. UV EPOXY TO RETAIN LED IN HOLDER.

UNCONTROLLED DOCUMENT

*UNLESS OTHERWISE SPECIFIED TOLERANCES PER DECIMAL PRECISION ARE: X=±1 (±0.039), X.X=±0.5 (±0.020), X.XX=±0.25 (±0.010), X.XXX=±0.127 (±0.005). LEAD SIZE=±0.05 (±0.002), LEAD LENGTH=±0.75 (±0.030). MIN.= +DECIMAL PRECISION -0.00 MAX.= +0.00 -DECIMAL PRECISION

REV. C	PART NUMBER SSI-LXH1090SRD-150
-----------	-----------------------------------

T-10mm 660nm SUPER RED LED PANEL INDICATOR,
RED DIFFUSED LENS, 6" WIRE LEADS.

CONFIDENTIAL INFORMATION
THE INFORMATION CONTAINED IN THIS DOCUMENT IS THE PROPERTY OF LUMEX INC. EXCEPT AS SPECIFICALLY AUTHORIZED IN WRITING BY LUMEX INC., THE HOLDER OF THIS DOCUMENT SHALL KEEP ALL INFORMATION CONTAINED HEREIN CONFIDENTIAL AND SHALL PROTECT SAME IN WHOLE OR IN PART FROM DISCLOSURE AND DISSEMINATION TO ALL THIRD PARTIES.

RELIABILITY NOTE
OUR MANY YEARS OF EXPERIENCE DATA ACCUMULATION INDICATE THAT SOLDER HEAT IS A MAJOR CAUSE OF EARLY AND FUTURE FAILURE. PLEASE PAY ATTENTION TO YOUR SOLDERING PROCESS.

LUMEX
Creating LED and LCD Solutions Together™

290 E. HELEN ROAD
PALATINE, IL 60067-6976
PHONE: +1.847.359.2790
US WEB: www.lumex.com
TW WEB: www.lumex.com.tw

DRAWN BY: BC	CHECKED BY:	APPROVED BY:	DATE: 6.15.95 PAGE: 1 OF 1 SCALE: N/A
-----------------	-------------	--------------	---