

BlueNRG-MS based Bluetooth® Smart USB

Data brief

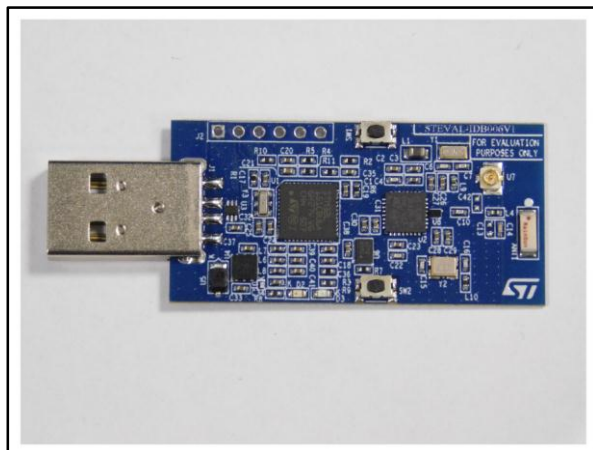

Features

- BlueNRG-MS based Bluetooth® Smart USB dongle for direct PC connection
- Maximum transmission power + 8 dBm
- Low power STM32L host microcontroller
- Major features of BlueNRG-MS: 7.3 mA (RX mode), 8.2 mA (TX mode at 0 dBm) maximum peak current, programmable output power from 18 dBm to +8dBm, up to 96 dB RF link budget
- USB Interface
- Bluetooth® low energy 4.1 compliant, supports both master and slave roles
- JTAG footprint connector for custom firmware development (JTAG connector not mounted)
- RoHS compliant

Description

The STEVAL-IDB006V1 is an evaluation board based on the BlueNRG-MS low power Bluetooth® Smart IC, compliant with the Bluetooth® 4.1 specifications and able to support both master and slave roles.

The STEVAL-IDB006V1 features an onboard, low-power STM32L microcontroller. It is primarily designed to interface with BlueNRG-MS, but can also be used for custom application development. The STEVAL-IDB006V1 has a USB connector for PC GUI interaction and firmware updates.

While the board does not come with a mounted JTAG connector, the footprint area is available. When a JTAG connector is soldered, users can develop custom firmware for the STM32L microcontroller.

1 Schematic diagram

Figure 1: STEVAL-IDB006V1 circuit schematic (1 of 5)

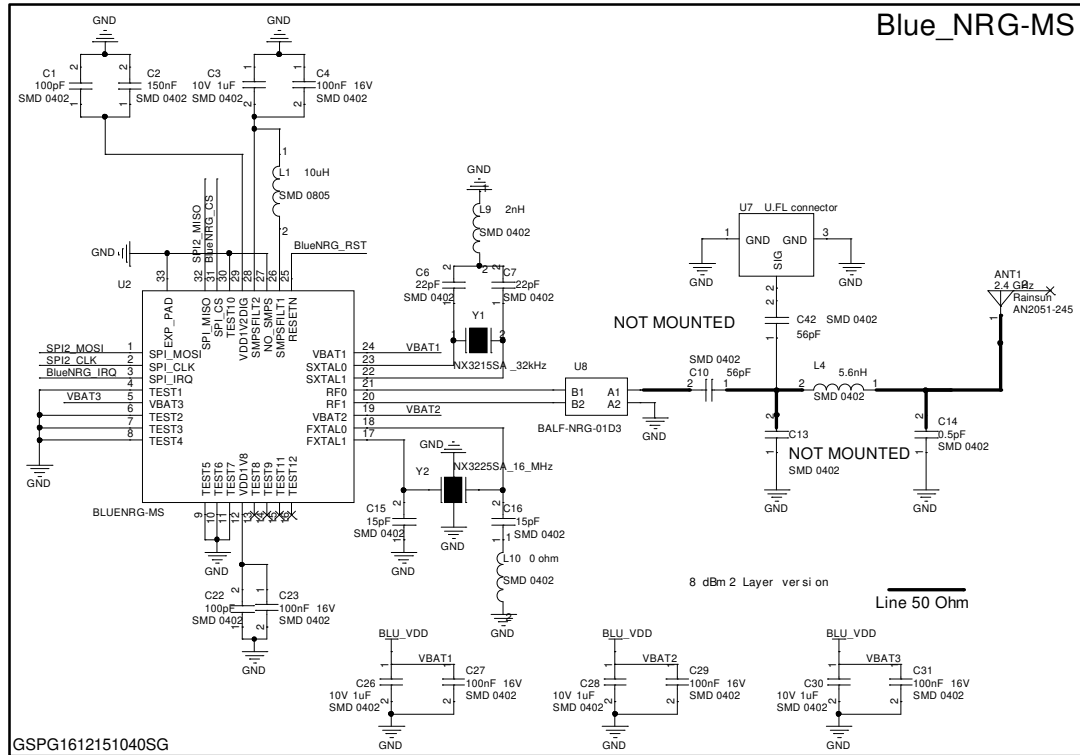

Figure 2: STEVAL-IDB006V1 circuit schematic (2 of 5)

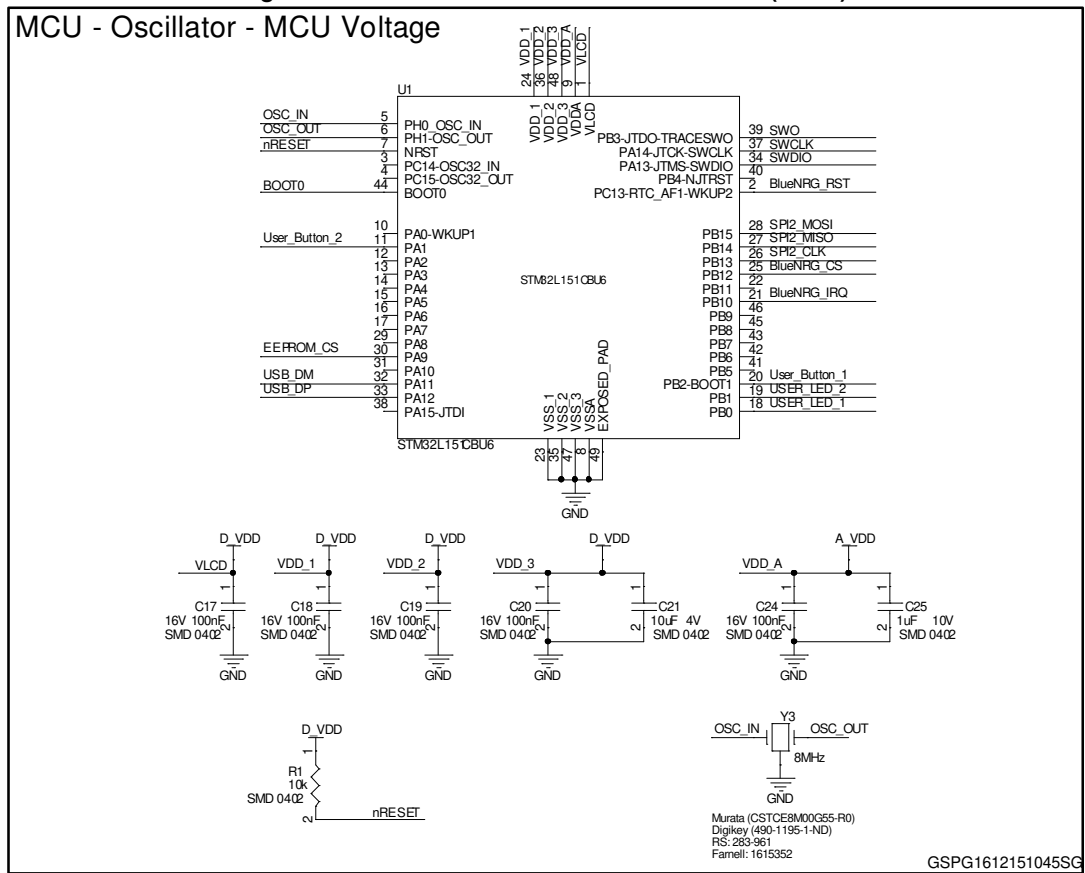

Figure 3: STEVAL-IDB006V1 circuit schematic (3 of 5)

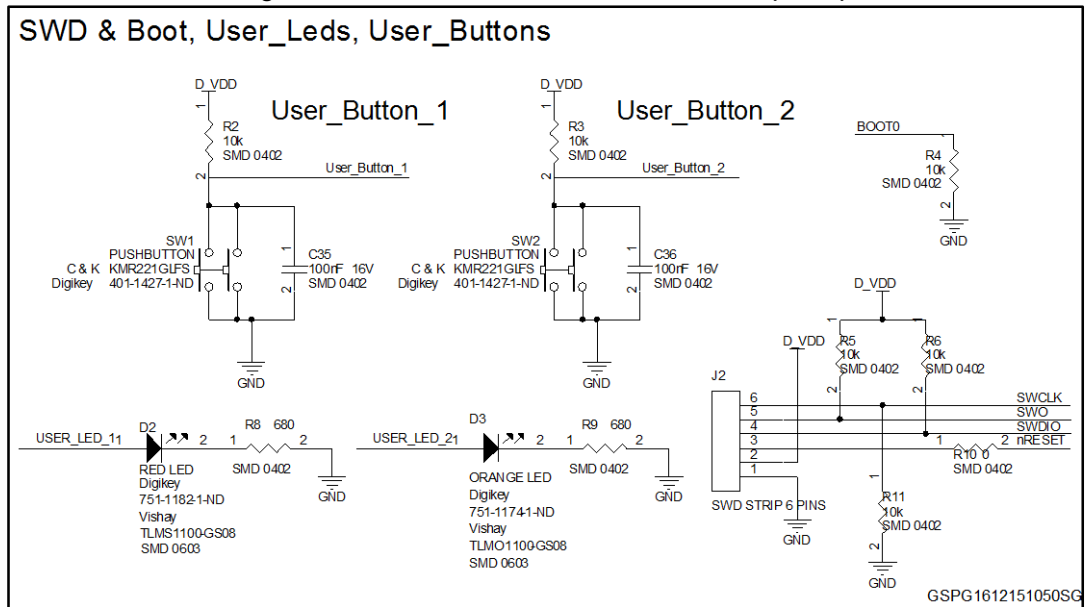

Figure 4: STEVAL-IDB006V1 circuit schematic (4 of 5)

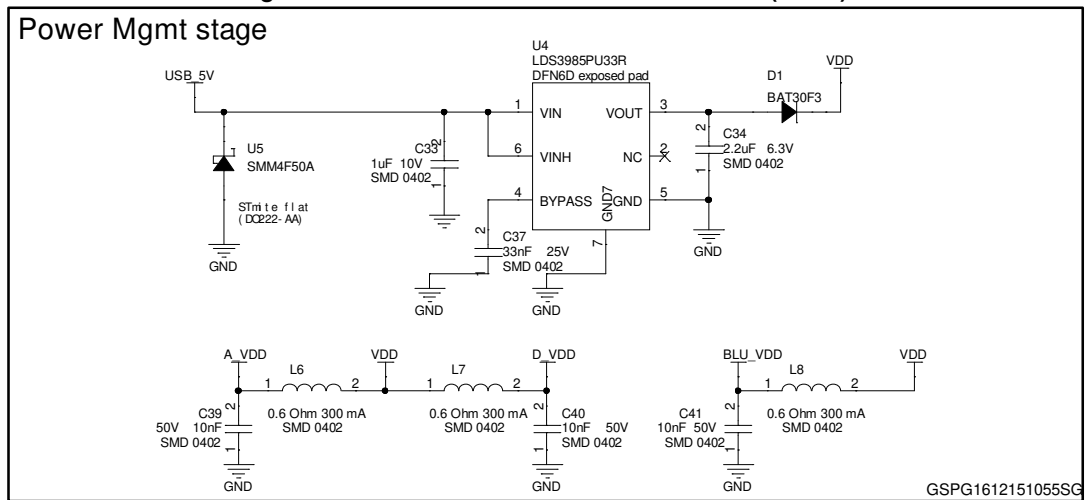
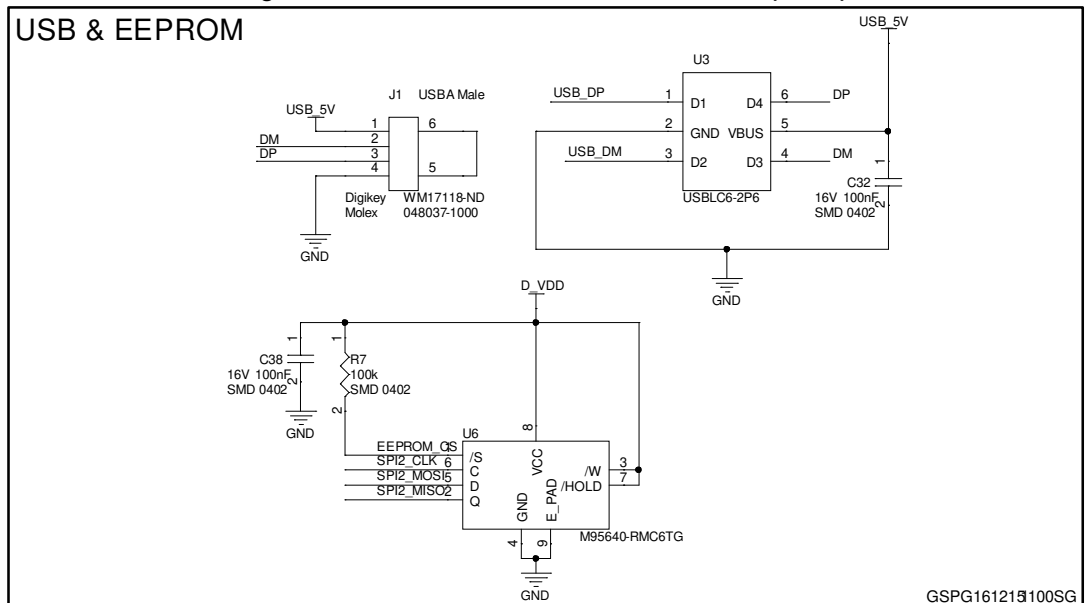

Figure 5: STEVAL-IDB006V1 circuit schematic (5 of 5)



2 Revision history

Table 1: Document revision history

Date	Version	Changes
18-Dec-2015	1	Initial release.

IMPORTANT NOTICE – PLEASE READ CAREFULLY

STMicroelectronics NV and its subsidiaries ("ST") reserve the right to make changes, corrections, enhancements, modifications, and improvements to ST products and/or to this document at any time without notice. Purchasers should obtain the latest relevant information on ST products before placing orders. ST products are sold pursuant to ST's terms and conditions of sale in place at the time of order acknowledgement.

Purchasers are solely responsible for the choice, selection, and use of ST products and ST assumes no liability for application assistance or the design of Purchasers' products.

No license, express or implied, to any intellectual property right is granted by ST herein.

Resale of ST products with provisions different from the information set forth herein shall void any warranty granted by ST for such product.

ST and the ST logo are trademarks of ST. All other product or service names are the property of their respective owners.

Information in this document supersedes and replaces information previously supplied in any prior versions of this document.

© 2015 STMicroelectronics – All rights reserved