

PARTIAL1

NOTES:

1. MATERIALS
HOUSING: UNFILLED NYLON 6/6, RATED UL 94V-2
FOR COLOURS, SEE CHARTS ON SHEETS 2-6.
TERMINALS: PHOSPHOR BRONZE, 0.40/(0.016) THICK REF.
PLATING: 5um/(200uin) MIN PURE Sn
2. PRODUCT CONFORMS TO SPECIFICATION PS-99020-0037
3. ACCEPTS CABLE, PER ES-99036-0008 OR ES-99036-0009
AS PER THE APPLICATION SPECIFICATION AS-99033-0004
4. SEE SUBSEQUENT SHEETS FOR PART NUMBERS SHOWING
THE VARIOUS CODING, KEYING AND LATCHING OPTIONS

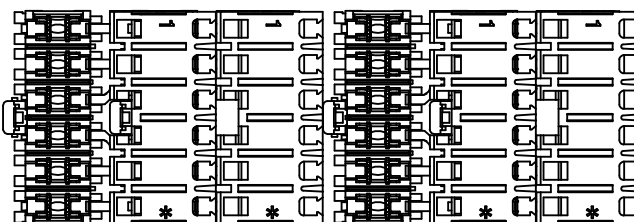
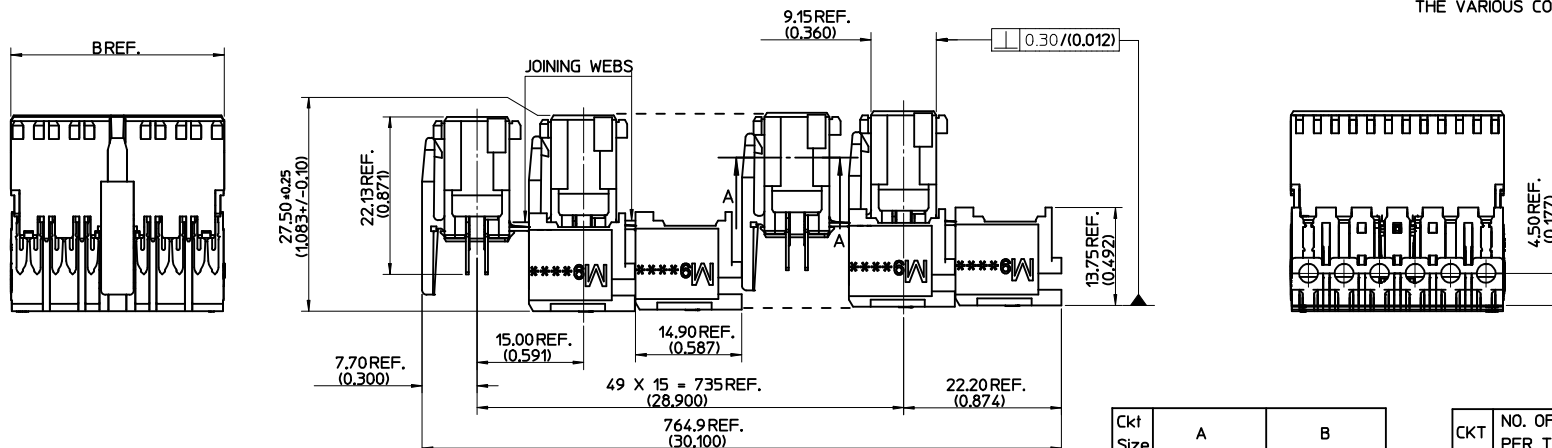

Ckt Size	A	B
2	5.00/(0.197)	9.90/(0.400)
3	10.00/(0.394)	14.90/(0.587)
4	15.00/(0.591)	19.90/(0.783)
5	20.00/(0.787)	24.90/(0.980)
6	25.00/(0.984)	29.90/(1.177)
7	30.00/(1.181)	34.90/(1.374)
8	35.00/(1.378)	39.90/(1.571)
9	40.00/(1.575)	44.90/(1.768)
10	45.00/(1.772)	49.90/(1.965)
11	50.00/(1.969)	54.90/(2.161)
12	55.00/(2.165)	59.90/(2.358)

CKT	NO. OF CONNECTORS PER TRAY, 99025-0021	NO. OF CONNECTORS PER BOX
2	1200	3600
3	750	2250
4	600	1800
5	450	1350
6	300	900
7	300	900
8	300	900
9	150	450
10	150	450
11	150	450
12	150	450

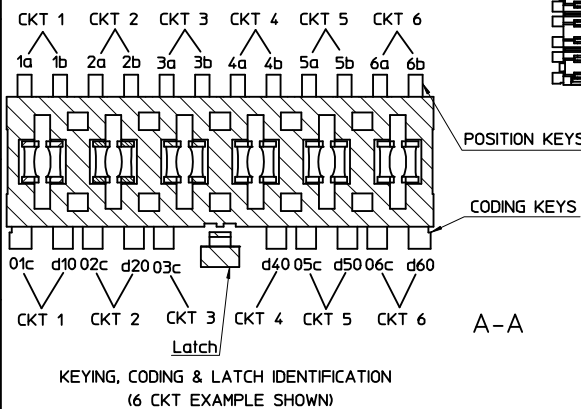

ADDED PART NO. EC NO: IPG2014-0066 DRWN: KOBRIEN01 2013/07/09 CHKD: APPR: SUGRIFLIN 2013/08/26 AF	DESCRIPTION QUALITY SYMBOLS ▽=0 ▽=0 DRAFT WHERE APPLICABLE MUST REMAIN WITHIN DIMENSIONS	GENERAL TOLERANCES (UNLESS SPECIFIED)		DIMENSION STYLE MM ONLY		SCALE 2:1	DESIGN UNITS METRIC	THIRD ANGLE PROJECTION	
		4 PLACES ± --- ± --- 3 PLACES ± 0.025 ± --- 2 PLACES ± 0.05 ± --- 1 PLACE ± 0.1 ± ---	mm INCH ± --- ± --- ± --- ± --- ± --- ± ---	DRAWN BY PC	DATE 94/02/14	TITLE 5MM APPLI-MATE 6A/10A F-INDIRECT CONN ASSY			
		ANGULAR ± 1/2°		CHECKED BY BMAGUIRE	DATE 94/02/14	MOLEX INCORPORATED			
		MATERIAL NO. SEE CHARTS		APPROVED BY MWILHITE	DATE 94/02/14	DOCUMENT NO. SD-90833-001		SHEET NO. 1 OF 8	

MOLEX PART NO	HOUSING NO.	CIRCUIT SIZE	COLOUR	POSITION KEYS	CODING KEYS	LATCH POSITION	CONFIGURATION	REF
90833-0001	90833-9001		NATURAL					
90833-0002	90833-9002	2	BLUE	ALL	ALL	1/2		K00
90833-0003	90833-9001		NATURAL					
90833-0051	90833-9004	2	YELLOW	1b 2a	ALL	1/2		K01
90833-0004	90833-9001		NATURAL					
90833-0050	90833-9004	2	YELLOW	1a 2b	01c	1/2		K02
90833-0026	90833-9005		GREEN					
90833-0005	90833-9002	2	BLUE	2a	ALL	1/2		K03
90833-0018	90833-9001		NATURAL					
90833-0053	90833-9004	2	NATURAL	2a				
90833-0006	90833-9003		GREY					
90833-0019	90833-9001	2	NATURAL	1a 2b	d20	1/2		K05
90833-0025	90833-9005		GREEN					
90833-0007	90833-9001		NATURAL					
90833-0008	90833-9004	2	YELLOW	1b 2b	01c	1/2		K09
90833-0076	90833-9007		ORANGE					
90833-0009	90833-9001		NATURAL					
90833-0010	90833-9004	2	YELLOW	1a 2a	01c	1/2		K10
90833-0054	90833-9001	2	NATURAL	2b	ALL	1/2		K15
90833-0058	90833-9001	2	NATURAL	1a 1b	ALL	1/2		K47
90833-0060	90833-9002	2	BLUE	1a 2b	ALL	1/2		K48
90833-0027	90833-9004	2	YELLOW	2b	NONE	1/2		K11
90833-0062	90833-9001	2	NATURAL					
90833-0066	90833-9001	2	NATURAL	1a 1b	01c	1/2		K04
90833-0028	90833-9001	2	NATURAL	2a	d20	1/2		k37
90833-0070	90833-9001	2	NATURAL	1a. 1b	d20	1/2		k13
90833-0071	90833-9001	2	NATURAL	2a. 2b	01c	1/2		k32

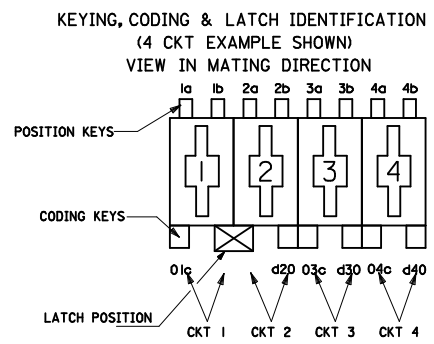

SEE SHEET 1 EC NO: IFCZ014-0066 DRWN: KOBRIEN01 2013/07/09 CHKD: APPR: STGRUFFIN 2013/08/26	QUALITY SYMBOLS	GENERAL TOLERANCES (UNLESS SPECIFIED)	DIMENSION STYLE	SCALE	DESIGN UNITS	THIRD ANGLE PROJECTION															
	$\nabla=0$ $\nabla=0$	<table border="1"> <tr> <th></th> <th>mm</th> <th>INCH</th> </tr> <tr> <td>4 PLACES</td> <td>±---</td> <td>±---</td> </tr> <tr> <td>3 PLACES</td> <td>±0.025</td> <td>±---</td> </tr> <tr> <td>2 PLACES</td> <td>±0.05</td> <td>±---</td> </tr> <tr> <td>1 PLACE</td> <td>±0.1</td> <td>±---</td> </tr> </table>		mm	INCH	4 PLACES	±---	±---	3 PLACES	±0.025	±---	2 PLACES	±0.05	±---	1 PLACE	±0.1	±---	MM ONLY	1:1	METRIC	
		mm	INCH																		
	4 PLACES	±---	±---																		
	3 PLACES	±0.025	±---																		
2 PLACES	±0.05	±---																			
1 PLACE	±0.1	±---																			
DESCRIPTION	DRAWN BY DATE		TITLE		MOLEX INCORPORATED SD-90833-001																
	PC 94/02/14		5MM APPLI-MATE 6A/10A F-INDIRECT CONN ASSY																		
	CHECKED BY DATE		MATERIAL NO.		DOCUMENT NO.																
	BMAGUIRE 94/02/14		MWLHTE 94/02/14		2 OF 8																
	APPROVED BY DATE		THIS DRAWING CONTAINS INFORMATION THAT IS PROPRIETARY TO MOLEX INCORPORATED AND SHOULD NOT BE USED WITHOUT WRITTEN PERMISSION																		
	AF																				

MOLEX PART NO	HOUSING NO.	CIRCUIT SIZE	COLOUR	POSITION KEYS	CODING KEYS	LATCH POSITION	CONFIGURATION	REF
90833-0011 90833-0057 90833-0061	90833-9002 90833-9001 90833-9004	2 2 2	BLUE NATURAL YELLOW	1a	ALL	1/2		K12
90833-0012 90833-0052	90833-9004 90833-9001	2	NATURAL YELLOW	1b 2a	0 1a	1/2		K14
90833-0013 90833-0014 90833-0048	90833-9001 90833-9004 90833-9005	2	NATURAL YELLOW GREEN	ALL	0 1a	1/2		K33
90833-0015 90833-0059 90833-0074	90833-9003 90833-9006 90833-9001	2	GREY WHITE NATURAL	ALL	d20	1/2		K34
90833-0016 90833-0069	90833-9003 90833-9001	2 2	GREY NATURAL	1b 2b	d20	1/2		K35
90833-0017 90833-0072	90833-9003 90833-9001	2	GREY NATURAL	2a, 2b	d20	1/2		K39
90833-0020	90833-9001	2	NATURAL	1a 1b	0 1a	1/2		K04
90833-0021 90833-0063	90833-9001 90833-9002	2 2	NATURAL BLUE	1b 1b	ALL	1/2 1/2		K16
90833-0022	90833-9001	2	NATURAL	1a 2b	NONE	1/2		K06
90833-0032	90833-9001	2	NATURAL	2b	d20	1/2		K38
90833-0047	90833-9001	2	NATURAL	1a 2a	ALL	1/2		K44
90833-0056	90833-9001	2	NATURAL	1b 2a 2b	d20	1/2		K07
90833-0064 90833-0073	90833-9006 90833-9001	2	WHITE NATURAL	1b, 2a	d20	1/2		K46
90833-0075	90833-9001	2	GREY	1a, 1b	d20	1/2		K13

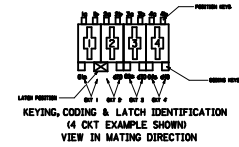

SEE SHEET 1 SEC NO: IPG2014-0066 DRAWN: KOBRIEN01 2013/07/09 CHKD: AF APPR: STRIFFEIN 2013/08/26	QUALITY SYMBOLS	GENERAL TOLERANCES (UNLESS SPECIFIED)	DIMENSION STYLE	SCALE	DESIGN UNITS	THIRD ANGLE PROJECTION	
	$\nabla=0$ $\nabla=0$	mm INCH 4 PLACES ± --- ± --- 3 PLACES ± 0.025 ± --- 2 PLACES ± 0.05 ± --- 1 PLACE ± 0.1 ± --- ANGULAR ± 1/2°	M M ONLY	1:1	METRIC		
	DRAFT WHERE APPLICABLE MUST REMAIN WITHIN DIMENSIONS	SEE CHARTS	DRAWN BY DATE PC 94/02/14 CHECKED BY DATE BMAGUIRE 94/02/14 APPROVED BY DATE MWILHITE 94/02/14	TITLE 5MM APPLI-MATE 6A/10A F-INDIRECT CONN ASSY	MOLEX INCORPORATED		
	MATERIAL NO. SD-90833-001	DOCUMENT NO. SD-90833-001	SHEET NO. 3 OF 8	THIS DRAWING CONTAINS INFORMATION THAT IS PROPRIETARY TO MOLEX INCORPORATED AND SHOULD NOT BE USED WITHOUT WRITTEN PERMISSION			

	13	12	11	10	9	8	7	6	5	4	3	2	1	
	MOLEX PART NO	HOUSING NO.	CIRCUIT SIZE	COLOUR	POSITION KEYS	CODING KEYS	LATCH POSITION	CONFIGURATION	REF					
J	90833-0500	90833-9021	3	NATURAL	ALL	ALL	1/2		K00					
	90833-0501	90833-9022	3	NATURAL	ALL	ALL	2/3		K90					
I	90833-0502	90833-9021	3	NATURAL	1b	01c d20	1/2		K01					
	90833-0503	90833-9023	3	YELLOW	ALL	d20	1/2		K40					
	90833-0504	90833-9026	3	GREY	ALL	d10	2/3		K41					
H	90833-0505	90833-9026	3	GREY	1a 2a	d10	2/3		K42					
	90833-0532	90833-9027	3	BLACK	1a 3a	d20	1/2		K43					
	90833-0506	90833-9023	3	YELLOW	ALL	d20	1/2		K43					
	90833-0507	90833-9024	3	YELLOW	2a	d10 d30	2/3		K44					
G	90833-0508	90833-9021	3	NATURAL	1a	03c	1/2		K04					
	90833-0509	90833-9026	3	GREY	1a 1b	d10	2/3		K52					
	90833-0510	90833-9023	3	YELLOW	1a 1b	d20	1/2		K53					
F	90833-0511	90833-9021	3	NATURAL	1a 1b	d30	1/2		K05					
	90833-0524	90833-9021	3	NATURAL	1b 2a 2b	d30	1/2		K33					
	90833-0526	90833-9022	3	NATURAL	ALL	d10 d30	2/3		K38					
E	90833-0528	90833-9021	3	NATURAL	1a 3a	01c	1/2		K07					
	90833-0529	90833-9021	3	NATURAL	1b 3a	01c	1/2		K03					
	90833-0533	90833-9025	3	GREY	ALL	01c	1/2		K03					
	90833-0530	90833-9022	3	NATURAL	2a	02c d30	2/3		K57					
D	90833-0531	90833-9021	3	NATURAL	2b	d20	1/2		K08					
	90833-0513	90833-9021	3	NATURAL	1b	d20 03c	1/2		K09					
	90833-0535	90833-9022	3	NATURAL	1a 2a	d30	2/3							
C	90833-0536	90833-9022	3	NATURAL	2a	d10 d30	2/3		K44					
	90833-0537	90833-9028	3	BLUE	1a	03c	1/2		K**					
B	90833-0534	90833-9022	3	NATURAL	1a 1b 2a 3a	01c 02a d30	2/3		K12					
	90833-0540	90833-9021	3	NATURAL	3b	01c d30	1/2		K37					
	90833-0541	90833-9022	3	NATURAL	2b 3b	d10 02c	2/3		K02					
	90833-0542	90833-9021	3	NATURAL	1a 3a	01c	1/2		K-					
A	90833-0543	90833-9021	3	NATURAL	1a 3a	03c	1/2		K98					

MOLEX PART NO	HOUSING NO.	CIRCUIT SIZE	COLOUR	POSITION KEYS	CODING KEYS	LATCH POSITION	CONFIGURATION	REF
90833-1251 90833-1252 90833-1253	90833-9101 90833-9103 90833-9102	4	NATURAL BLUE YELLOW	ALL	ALL	1/2 3/4		K00
90833-1254	90833-9101	4	NATURAL	1b	03c d40	1/2 3/4		K01
90833-1255	90833-9102	4	YELLOW	3a	d20 03c	1/2 3/4		K33
90833-1256	90833-9103	4	BLUE	ALL	01c	1/2 3/4		K34
90833-1257	90833-9101	4	NATURAL	ALL	d20 03c	1/2 3/4		K35
90833-1258	90833-9103	4	BLUE	ALL	d40	1/2 3/4		K36
90833-1259	90833-9101	4	NATURAL	1b	d20 03c	1/2 3/4		K38
90833-1260	90833-9103	4	BLUE	1b 2a	d40	1/2 3/4		K39
90833-1261	90833-9103	4	BLUE	1b 3b	d40	1/2 3/4		K49
90833-1262	90833-9103	4	BLUE	1b 3b	01c	1/2 3/4		K54
90833-1264	90833-9101	4	NATURAL	1a 4b	d40	1/2 3/4		K03
90833-1271	90833-9104	4	ORANGE	1a 3a	d40	1/2 3/4		K06
90833-1272	90833-9105	4	GREY	1b	03c d40	1/2 3/4		K01
90833-1273	90833-9101	4	NATURAL	1a 3a 3b	01c d20 d40	1/2 3/4		K32
90833-1277	90833-9102	4	YELLOW	1a 2b 4b	d40	1/2 3/4		K62
90833-1267	90833-9101	4	NATURAL	1b 2a 3a 4b	01c d40	1/2 3/4		K37
90833-1279	90833-9101	4	NATURAL	1a 4b	01c	1/2 3/4		K02
90833-1282	90833-9103	4	NATURAL	1a 2a 4a	01c 03c d40	1/2 3/4		K43
90833-1276	90833-9106	4	NATURAL	3b	d30	2/3		K04
90833-1283	90833-9101	4	NATURAL	1a 1b 3a 3b	01c 03c	1/2 3/4		K93
90833-1284	90833-9101	4	NATURAL	1a 3a	01c d40	1/2 3/4		K87

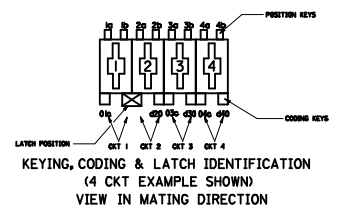

SEE SHEET 1 EC NO: IP02014-0066 DRAWN: KOBRIEN01 2013/07/09 CHKD: SGRIFFIN APPR: SGRIFFIN 2013/08/26 AF	QUALITY SYMBOLS 	GENERAL TOLERANCES (UNLESS SPECIFIED) <table border="1"> <tr> <td></td> <td>mm</td> <td>INCH</td> </tr> <tr> <td>4 PLACES</td> <td>± .005</td> <td>± .0004</td> </tr> <tr> <td>3 PLACES</td> <td>± 0.025</td> <td>± .0010</td> </tr> <tr> <td>2 PLACES</td> <td>± 0.05</td> <td>± .0020</td> </tr> <tr> <td>1 PLACE</td> <td>± 0.1</td> <td>± .0040</td> </tr> </table>		mm	INCH	4 PLACES	± .005	± .0004	3 PLACES	± 0.025	± .0010	2 PLACES	± 0.05	± .0020	1 PLACE	± 0.1	± .0040	DIMENSION STYLE MM ONLY DRAWN BY: PC DATE: 94/02/14 CHECKED BY: BMAGUIRE DATE: 94/02/14 APPROVED BY: MWILHITE DATE: 94/02/14 MATERIAL NO.	SCALE: 1:1 DESIGN UNITS: METRIC THIRD ANGLE PROJECTION	TITLE: 5MM APPLI-MATE 6A/10A F-INDIRECT CONN ASSY
				mm	INCH															
4 PLACES	± .005	± .0004																		
3 PLACES	± 0.025	± .0010																		
2 PLACES	± 0.05	± .0020																		
1 PLACE	± 0.1	± .0040																		
DRAFT WHERE APPLICABLE MUST REMAIN WITHIN DIMENSIONS	SEE CHARTS THIS DRAWING CONTAINS INFORMATION THAT IS PROPRIETARY TO MOLEX INCORPORATED AND SHOULD NOT BE USED WITHOUT WRITTEN PERMISSION	DOCUMENT NO.: SD-90833-001 SHEET NO.: 4 OF 8																		

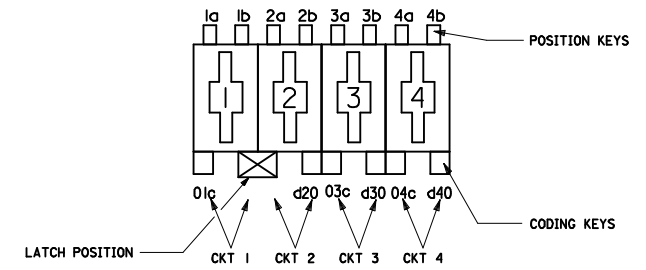

MOLEX PART NO	HOUSING NO.	CIRCUIT SIZE	COLOUR	POSITION KEYS	CODING KEYS	LATCH POSITION	CONFIGURATION	REF.
90833-2001	90833-9203	5	NATURAL	1a 3a	01c d30	1/2 4/5		K30
90833-2002	90833-9201	5	NATURAL	1a 5b	01c d20 03c d50	1/2 3/4		K31
90833-2006	90833-9202	5	NATURAL	2a	01c d50	2/3 4/5		K43
90833-2007	90833-9202	5	NATURAL	ALL	01c d50	2/3 4/5		K42
90833-2008	90833-9202	5	NATURAL	ALL	ALL	2/3 4/5		K92
90833-2010	90833-9201	5	NATURAL	ALL	ALL	1/2 3/4		K00
90833-2011	90833-9203	5	NATURAL	ALL	ALL	1/2 4/5		K90
90833-2012	90833-9201	5	NATURAL	2a 4b	01c d20 d40	1/2 3/4		K44
90833-2019	90833-9203	5	NATURAL	1a 3a	01c d30 d50	1/2 4/5		K49
90833-2023	90833-9204	5	BLUE	NONE	d20 d40	1/2 3/4		K75
90833-2025	90833-9201	5	NATURAL	NONE	01c d40	1/2 3/4		K**
90833-2026	90833-9205	5	GREEN	2b	d20 d50	1/2 3/4		K**
90833-2027	90833-9201	5	NATURAL	1a 5b	01c d20 03c d50	1/2 3/4		K31
90833-2028	90833-9203	5	NATURAL	1a 4a	d30	1/2 4/5		K04
90833-2029	90833-9206	5	NATURAL	1a 3a	01c d50	1/2		K**

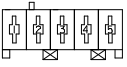

KEYING, CODING & LATCH IDENTIFICATION
(4 CKT EXAMPLE SHOWN)
VIEW IN MATING DIRECTION

SEE SHEET 1 EC NO: IPG2014-0066 DRAWN: KOBRIEN01 2013/07/09 CHKD: AF APPR: STGRIFFIN 2013/08/26	QUALITY SYMBOLS ▼=0 ▽=0	GENERAL TOLERANCES (UNLESS SPECIFIED) <table border="1"> <tr> <th></th> <th>mm</th> <th>INCH</th> </tr> <tr> <td>4 PLACES</td> <td>±.005</td> <td>±.0004</td> </tr> <tr> <td>3 PLACES</td> <td>±0.025</td> <td>±.001</td> </tr> <tr> <td>2 PLACES</td> <td>±0.05</td> <td>±.002</td> </tr> <tr> <td>1 PLACE</td> <td>±0.1</td> <td>±.004</td> </tr> </table>		mm	INCH	4 PLACES	±.005	±.0004	3 PLACES	±0.025	±.001	2 PLACES	±0.05	±.002	1 PLACE	±0.1	±.004	DIMENSION STYLE MM ONLY	SCALE 1:1	DESIGN UNITS METRIC	THIRD ANGLE PROJECTION
		mm	INCH																		
	4 PLACES	±.005	±.0004																		
	3 PLACES	±0.025	±.001																		
2 PLACES	±0.05	±.002																			
1 PLACE	±0.1	±.004																			
DRAFT WHERE APPLICABLE MUST REMAIN WITHIN DIMENSIONS	DRAWN BY: PC CHECKED BY: BMAGUIRE APPROVED BY: MWILHITE	DATE: 94/02/14 DATE: 94/02/14 DATE: 94/02/14	TITLE 5MM APPLI-MATE 6A/10A F-INDIRECT CONN ASSY	MATERIAL NO. SEE CHARTS	DOCUMENT NO. SD-90833-001	SHEET NO. 5 OF 8															
THIS DRAWING CONTAINS INFORMATION THAT IS PROPRIETARY TO MOLEX INCORPORATED AND SHOULD NOT BE USED WITHOUT WRITTEN PERMISSION																					

MOLEX PART NO	HOUSING NO.	CIRCUIT SIZE	COLOUR	POSITION KEYS	CODING KEYS	LATCH POSITION	CONFIRGURATION	REF.
90833-2024	90833-9202	5	NATURAL	2a	01C, d50	2/3, 4/5		K43

SEE SHEET 1 EC NO: IPC2014-0066 DRWN:KORRIEN01 2013/07/09 CHKD: AF APPR:STGRUFFIN 2013/08/26	QUALITY SYMBOLS	GENERAL TOLERANCES (UNLESS SPECIFIED)	DIMENSION STYLE	SCALE	DESIGN UNITS	THIRD ANGLE PROJECTION																		
	$\nabla=0$ $\sphericalangle=0$	<table border="1"> <thead> <tr> <th></th> <th>mm</th> <th>INCH</th> </tr> </thead> <tbody> <tr> <td>4 PLACES</td> <td>± ---</td> <td>± ---</td> </tr> <tr> <td>3 PLACES</td> <td>± 0.025</td> <td>± ---</td> </tr> <tr> <td>2 PLACES</td> <td>± 0.05</td> <td>± ---</td> </tr> <tr> <td>1 PLACE</td> <td>± 0.1</td> <td>± ---</td> </tr> <tr> <td colspan="3">ANGULAR ± 1/2°</td> </tr> </tbody> </table>		mm	INCH	4 PLACES	± ---	± ---	3 PLACES	± 0.025	± ---	2 PLACES	± 0.05	± ---	1 PLACE	± 0.1	± ---	ANGULAR ± 1/2°			MM ONLY DRAWN BY: PC DATE: 94/02/14 CHECKED BY: BMAGUIRE DATE: 94/02/14 APPROVED BY: MWILHITE DATE: 94/02/14	1:1	METRIC	
		mm	INCH																					
	4 PLACES	± ---	± ---																					
3 PLACES	± 0.025	± ---																						
2 PLACES	± 0.05	± ---																						
1 PLACE	± 0.1	± ---																						
ANGULAR ± 1/2°																								
DESCRIPTION	DRAFT WHERE APPLICABLE MUST REMAIN WITHIN DIMENSIONS	SEE CHARTS MATERIAL NO. A2 SIZE A2	TITLE 5MM APPLI-MATE 6A/10A F-INDIRECT CONN ASSY		 MOLEX INCORPORATED DOCUMENT NO. SD-90833-001																			
REV						SHEET NO. 6 OF 8																		

MOLEX PART NO	HOUSING NO.	CIRCUIT SIZE	COLOUR	POSITION KEYS	CODING KEYS	LATCH POSITION	CONFIGURATION	REF.
90833-2750	90833-9301	6	NATURAL	ALL	ALL	2/3 4/5		K90
90833-2751	90833-9302	6	GREY	ALL	02c d50	2/3 4/5		K38
90833-2752	90833-9302	6	GREY	1b	02c d50	2/3 4/5		K40
90833-2765	90833-9303	6	NATURAL	1b	03c d60	1/2 5/6		K91
90833-2764	90833-9303	6	NATURAL	ALL	ALL	1/2 5/6		K53
90833-2773	90833-9303	6	NATURAL	5b	01c d40	1/2 5/6		K61
90833-2776	90833-9303	6	NATURAL	1b 6a	d30	1/2 5/6		
90833-2777	90833-9303	6	NATURAL	2b 6b	d40	1/2 5/6		K04
90833-2778	90833-9304	6	BLUE	1b	d10 d50	2/3 4/5		K88
90833-2779	90833-9305	6	NATURAL	5b	02C, 06C	3/4		K**
90833-2780	90833-9306	6	NATURAL	1b 2a	d20 03c d60	1/2 4/5		K**
90833-2781	90833-9303	6	NATURAL	NONE	d20, d60	1/2, 5/6		K108

MOLEX PART NO	HOUSING NO.	CIRCUIT SIZE	COLOUR	POSITION KEYS	CODING KEYS	LATCH POSITION	CONFIGURATION	REF.
90833-3500	90833-9401	7	YELLOW	2b	d20 d60	1/2 5/6		K32
90833-3501	90833-9401	7	YELLOW	ALL	d20 d60	1/2 5/6		K33
90833-3502	90833-9401	7	YELLOW	ALL	d20 07c	1/2 5/6		K36
90833-3503	90833-9401	7	YELLOW	2b	d20 07c	1/2 5/6		K37
90833-3521	90833-9402	7	NATURAL	2b	d20 07c	1/2 5/6		
90833-3513	90833-9402	7	NATURAL	ALL	ALL	1/2 5/6		K00
90833-3514	90833-9402	7	NATURAL	NONE	d20	1/2 5/6		K44
90833-3518	90833-9403	7	NATURAL	ALL	ALL	2/3 6/7		K90
90833-3520	90833-9403	7	NATURAL	ALL	02c d50	2/3 6/7		K49
90833-3522	90833-9404	7	NATURAL	NONE	d20 03c 07c	5/6		K**
90833-3523	90833-9405	7	NATURAL	1a 6b	03c 07c	4/5		K**
90833-3524	90833-9402	7	NATURAL	1a 1b 2a 3a 4b 5b 6a 6b 7b	d20 07c	1/2 5/6		K**
90833-3521	90833-9402	7	NATURAL	2b	d20 07c	1/2 5/6		K37

MOLEX PART NO	HOUSING NO.	CIRCUIT SIZE	COLOUR	POSITION KEYS	CODING KEYS	LATCH POSITION	CONFIGURATION	REF.
90833-4250	90833-9501	8	NATURAL	ALL	ALL	3/4 5/6		K00
90833-4251	90833-9501	8	NATURAL	1b 3a 3b 5a 5b 7a 8a	01c d20 03c 05c 07c	3/4 5/6		K36
90833-4256	90833-9502	8	NATURAL	ALL	ALL	1/2 7/8		K90
90833-4255	90833-9502	8	NATURAL	ALL	03c d60	1/2 7/8		K39
90833-4261	90833-9503	8	BLUE	ALL	ALL	1/2 7/8		
90833-4254	90833-9502	8	NATURAL	2b 8a	03c d60	1/2 7/8		
90833-4264	90833-9504	8	NATURAL	8b	02c d30 07c	2/3 7/8		

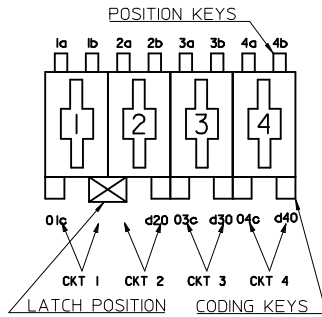

KEYING, CODING & LATCH IDENTIFICATION
(4CKT EXAMPLE SHOWN)
VIEW IN MATING DIRECTION

SEE SHEET 1 EC NO: IFC2014-0066 DRAWN: KOBRIEN01 2013/07/09 CHKO: APPR: SUGRIFIN 2013/08/26 AF	QUALITY SYMBOLS 	GENERAL TOLERANCES (UNLESS SPECIFIED) <table border="1"> <tr> <td></td> <td>mm</td> <td>INCH</td> </tr> <tr> <td>4 PLACES</td> <td>± ---</td> <td>± ---</td> </tr> <tr> <td>3 PLACES</td> <td>± 0.025</td> <td>± ---</td> </tr> <tr> <td>2 PLACES</td> <td>± 0.05</td> <td>± ---</td> </tr> <tr> <td>1 PLACE</td> <td>± 0.1</td> <td>± ---</td> </tr> </table>		mm	INCH	4 PLACES	± ---	± ---	3 PLACES	± 0.025	± ---	2 PLACES	± 0.05	± ---	1 PLACE	± 0.1	± ---	DIMENSION STYLE MM ONLY	SCALE 1:1	DESIGN UNITS METRIC	THIRD ANGLE PROJECTION
		mm	INCH																		
	4 PLACES	± ---	± ---																		
	3 PLACES	± 0.025	± ---																		
2 PLACES	± 0.05	± ---																			
1 PLACE	± 0.1	± ---																			
DRAFT WHERE APPLICABLE MUST REMAIN WITHIN DIMENSIONS	DRAWN BY PC DATE 94/02/14	CHECKED BY BMAGUIRE DATE 94/02/14	APPROVED BY MWILHITE DATE 94/02/14	TITLE 5MM APPLI-MATE 6A/10A F-INDIRECT CONN ASSY	MATERIAL NO. SD-90833-001	DOCUMENT NO. 7 OF 8															
THIS DRAWING CONTAINS INFORMATION THAT IS PROPRIETARY TO MOLEX INCORPORATED AND SHOULD NOT BE USED WITHOUT WRITTEN PERMISSION																					
SIZE A																					

MOLEX PART NO	HOUSING NO.	CIRCUIT SIZE	COLOUR	POSITION KEYS	CODING KEYS	LATCH POSITION	CONFIGURATION	REF
90833-5000	90833-9601	9	NATURAL	ALL	ALL	3/4 6/7		K00
90833-5001	90833-9601	9	NATURAL	1b 2a 3a 5a 6a 7b 8b	01c 03c d70 08c d90	3/4 6/7		K30
90833-5010	90833-9603	9	NATURAL	2b 5a	d80	2/3 7/8		K03
90833-5012	90833-9602	9	NATURAL	1b	03c	5/6		K0A

MOLEX PART NO	HOUSING NO.	CIRCUIT SIZE	COLOUR	POSITION KEYS	CODING KEYS	LATCH POSITION	CONFIGURATION	REF
90833-6000	90833-9701	10	NATURAL	ALL	ALL	3/4 7/8		K00
90833-6001	90833-9701	10	NATURAL	1a 3b 7b 8a	01c d20 d40 05c d100	3/4 7/8		K34
90833-6005	90833-9702	10	NATURAL	ALL	ALL	4/5 7/8		K98
90833-6006	90833-9703	10	NATURAL	ALL	ALL	4/5 6/7		K99
90833-6007	90833-9702	10	NATURAL	1a 10b	07c	4/5 7/8		K39
90833-6008	90833-9703	10	NATURAL	1b 9a	06c	4/5 6/7		K40
90833-6023	90833-9704	10	NATURAL	1b	03c	5/6		K
90833-6024	90833-9704	10	NATURAL	4b 6b 8a 8b	d100	5/6		K**
90833-6025	90833-9705	10	NATURAL	4b 6b 8a 8b	06c d100	NONE		K**

MOLEX PART NO	HOUSING NO.	CIRCUIT SIZE	COLOUR	POSITION KEYS	CODING KEYS	LATCH POSITION	CONFIGURATION	REF
90833-7000	90833-9801	11	NATURAL	ALL	ALL	3/4 8/9		K00
90833-7001	90833-9801	11	NATURAL	1a 2b 3b 4a 4b 5a 7a 8a 9a 10a 11a	01c d40 05c 08c 10c	3/4 8/9		K33

MOLEX PART NO	HOUSING NO.	CIRCUIT SIZE	COLOUR	POSITION KEYS	CODING KEYS	LATCH POSITION	CONFIGURATION	REF
90833-8000	90833-9901	12	NATURAL	ALL	ALL	3/4 9/10		K00
90833-8001	90833-9901	12	NATURAL	1a 2a 4a 4b 5a 6b 8a 11a	01c 03c 05c 07c d80 d10 11c	3/4 9/10		K41

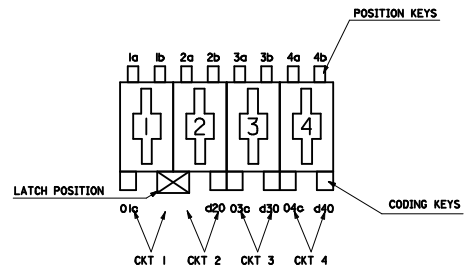

KEYING, CODING & LATCH IDENTIFICATION
(4 CKT EXAMPLE SHOWN)
VIEW IN MATING DIRECTION

SEE SHEET 1 EC NO: IFC2014-0066 DRWN: KOBRIEN01 2013/07/09 CHKD: APPR: STGRUFFIN 2013/08/26 AF	DESCRIPTION 5MM APPLI-MATE 6A/10A F-INDIRECT CONN ASSY	QUALITY SYMBOLS ▼=0 ▽=0	GENERAL TOLERANCES (UNLESS SPECIFIED) <table border="1"> <tr> <th></th> <th>mm</th> <th>INCH</th> </tr> <tr> <td>4 PLACES</td> <td>±---</td> <td>±---</td> </tr> <tr> <td>3 PLACES</td> <td>±0.025</td> <td>±---</td> </tr> <tr> <td>2 PLACES</td> <td>±0.05</td> <td>±---</td> </tr> <tr> <td>1 PLACE</td> <td>±0.1</td> <td>±---</td> </tr> <tr> <td colspan="3">ANGULAR ±1/2°</td> </tr> </table>		mm	INCH	4 PLACES	±---	±---	3 PLACES	±0.025	±---	2 PLACES	±0.05	±---	1 PLACE	±0.1	±---	ANGULAR ±1/2°			DIMENSION STYLE MM ONLY	SCALE 1:1	DESIGN UNITS METRIC	THIRD ANGLE PROJECTION
		mm	INCH																						
	4 PLACES	±---	±---																						
	3 PLACES	±0.025	±---																						
2 PLACES	±0.05	±---																							
1 PLACE	±0.1	±---																							
ANGULAR ±1/2°																									
DRAWN BY: PC DATE: 94/02/14 CHECKED BY: BMAGUIRE DATE: 94/02/14 APPROVED BY: MWILHITE DATE: 94/02/14 MATERIAL NO.: DOCUMENT NO.:		TITLE 5MM APPLI-MATE 6A/10A F-INDIRECT CONN ASSY		MOLEX INCORPORATED		SHEET NO. 8 OF 8																			
DRAFT WHERE APPLICABLE MUST REMAIN WITHIN DIMENSIONS		SEE CHARTS		SD-90833-001		THIS DRAWING CONTAINS INFORMATION THAT IS PROPRIETARY TO MOLEX INCORPORATED AND SHOULD NOT BE USED WITHOUT WRITTEN PERMISSION																			
SIZE A2																									