

**AT91SAM7X-EK  
Evaluation Board  
for AT91SAM7X and AT91SAM7XC**

---

**User Guide**





# Table of Contents

---

## Section 1

Overview .....	1-1
1.1 Scope .....	1-1
1.2 Deliverables .....	1-1
1.3 The AT91SAM7X-EK Evaluation Board .....	1-1

---

## Section 2

Setting Up the AT91SAM7X-EK Evaluation Board .....	2-1
2.1 Electrostatic Warning .....	2-1
2.2 Requirements .....	2-1
2.3 Layout .....	2-2
2.4 Powering Up the Board .....	2-3
2.5 Getting Started .....	2-3
2.6 AT91SAM7X-EK Block Diagram .....	2-4

---

## Section 3

Board Description .....	3-1
3.1 AT91SAM7X Microcontroller .....	3-1
3.2 AT91SAM7X Block Diagram .....	3-4
3.3 AT91SAM7XC Microcontroller .....	3-5
3.4 AT91SAM7XC Export Regulations Statement .....	3-7
3.5 AT91SAM7XC Block Diagram .....	3-8
3.6 Memory .....	3-9
3.7 Clock Circuitry .....	3-9
3.8 Reset Circuitry .....	3-9
3.9 Power Supply Circuitry .....	3-9
3.10 Remote Communication .....	3-9
3.11 Analog Interface .....	3-9
3.12 User Interface .....	3-9
3.13 Debug Interface .....	3-10
3.14 Expansion Slot .....	3-10

---

## Section 4

Configuration Straps .....	4-1
4.1 Configuration Straps .....	4-1

---

## Section 5

Schematics .....	5-1
5.1 Schematics .....	5-1

---

**Section 6**

Errata ..... 6-1  
    6.1 Errata .....6-1

---

**Section 7**

Revision History ..... 7-1  
    7.1 Revision History .....7-1





# Section 1

---

## Overview

- 
- 1.1 Scope** The AT91SAM7X-EK and the AT91SAM7XC-EK evaluation kits enable evaluation capabilities and code development of applications running on the AT91SAM7X or the AT91SAM7XC microcontroller.
- This guide focuses on the AT91SAM7X-EK board as a common evaluation platform for the AT91SAM7X and AT91SAM7XC devices in a 100-lead LQFP package.
- 
- 1.2 Deliverables** The package contains the following items:
- a board marked AT91SAM7X-EK
  - one A/B-type USB cable
  - one crossed serial RS232 cable
  - one RJ45 crossed Ethernet cable
  - universal input AC/DC power supply with US and EU plug adapter
  - one DVD-ROM containing summary and full datasheets, datasheets with electrical and mechanical characteristics, application notes and getting started documents for all development boards and AT91 microcontrollers. An AT91 software package with C and assembly listings is also provided. This allows the user to begin evaluating the AT91 ARM<sup>®</sup> Thumb<sup>®</sup> 32-bit microcontroller quickly.
- 
- 1.3 The AT91SAM7X-EK Evaluation Board** Depending on the model of the kit, the board is equipped with either an AT91SAM7X256 or an AT91SAM7XC256 (100-pin LQFP Green package) together with the following interfaces:
- USB device port
  - DBGU serial communication port
  - RS232 serial communication port with RTS/CTS
  - JTAG/ICE debug interface connector
  - serial CAN communication ports
  - MII Ethernet 100-base TX with auto MDIX capability
  - buffered analog input and PWM output

## **Overview**

- Power LED and general-purpose LEDs
- DataFlash® card slot
- expansion connector
- Atmel® serial DataFlash
- One footprint for Atmel Serial EEPROM (MN11)



## Section 2

---

# Setting Up the AT91SAM7X-EK Evaluation Board

- 
- 2.1 Electrostatic Warning** The AT91SAM7X-EK evaluation board is shipped in a protective anti-static package. The board must not be subjected to high electrostatic potentials. A grounding strap or similar protective device should be worn when handling the board. Avoid touching the component pins or any other metallic element.
- 
- 2.2 Requirements** In order to set up the AT91SAM7X-EK evaluation board, the following items are required:
- the AT91SAM7X-EK evaluation board itself
  - an A/B-type USB cable
- or
- a DC USB power adapter (5V at 0.5 A) with USB A/B cable
- Note:** The kit is not delivered with a JTAG/ICE interface which is required to start evaluating the device.

## 2.3 Layout

Figure 2-1. Layout - Top View

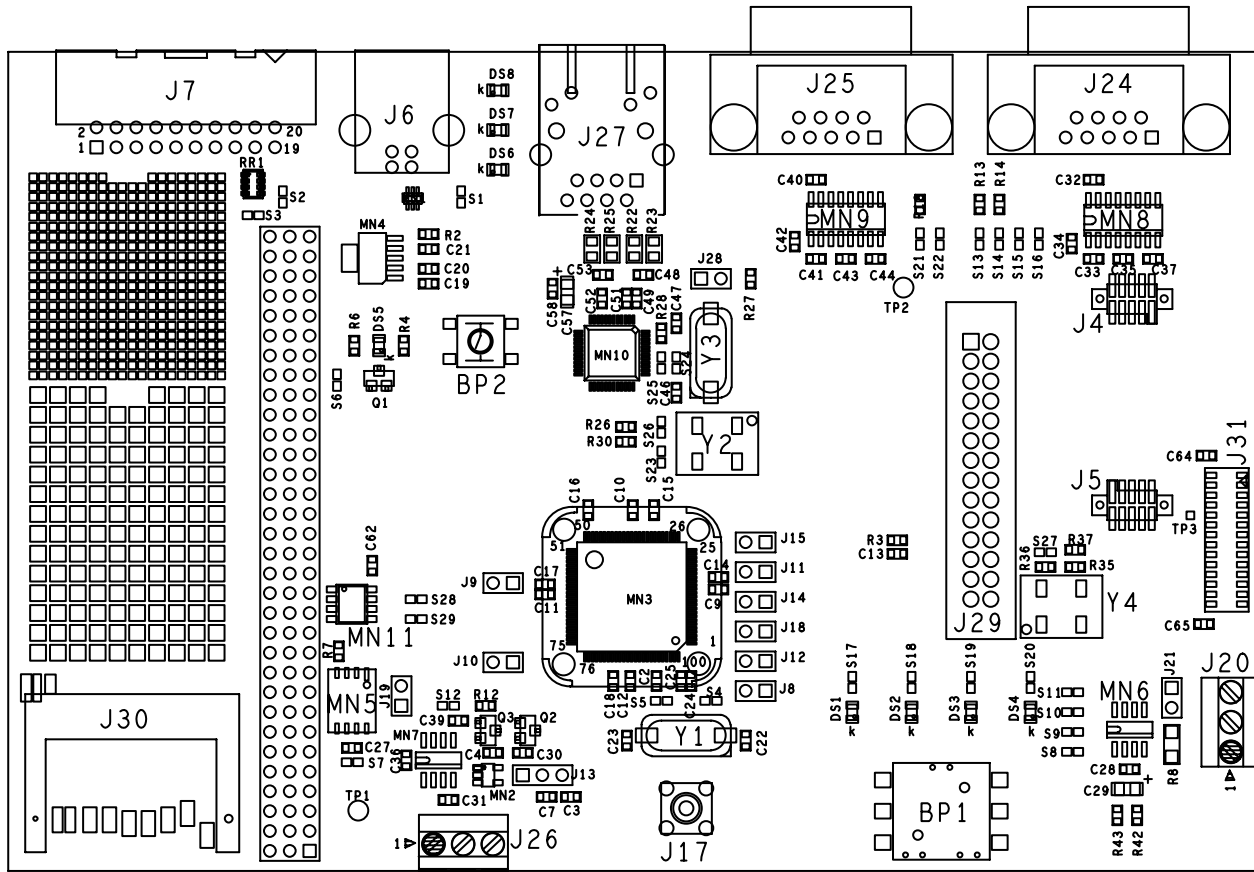
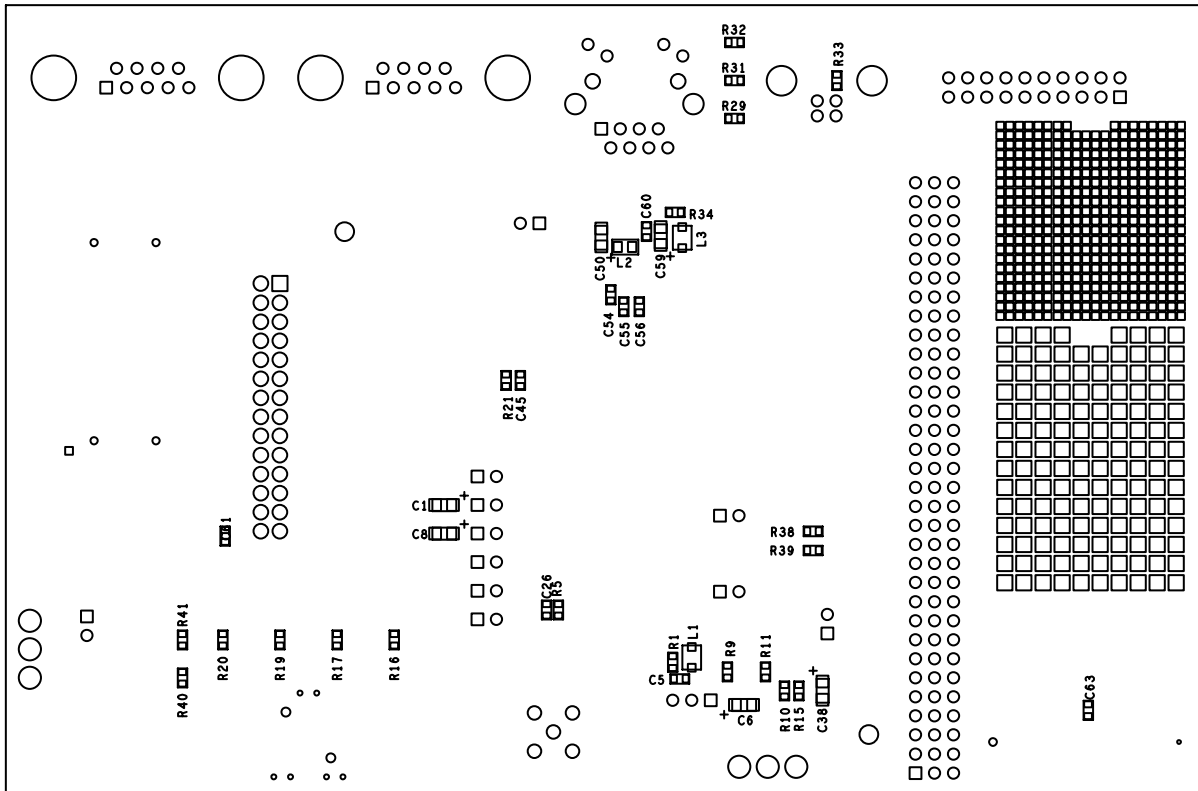



Figure 2-2. Layout - Bottom View



**2.4 Powering Up the Board** The AT91SAM7X-EK board is self-powered by the USB port or by a USB power adapter.

**2.5 Getting Started** The AT91SAM7X-EK evaluation board is delivered with a DVD-ROM containing all necessary information and step-by-step procedures for working with the most common development tool chains. Please refer to this DVD-ROM, or to the AT91 web site, <http://www.atmel.com/products/AT91/>, for the most up-to-date information on getting started with the evaluation kit.

## 2.6 AT91SAM7X-EK Block Diagram

Figure 2-3. Block Diagram

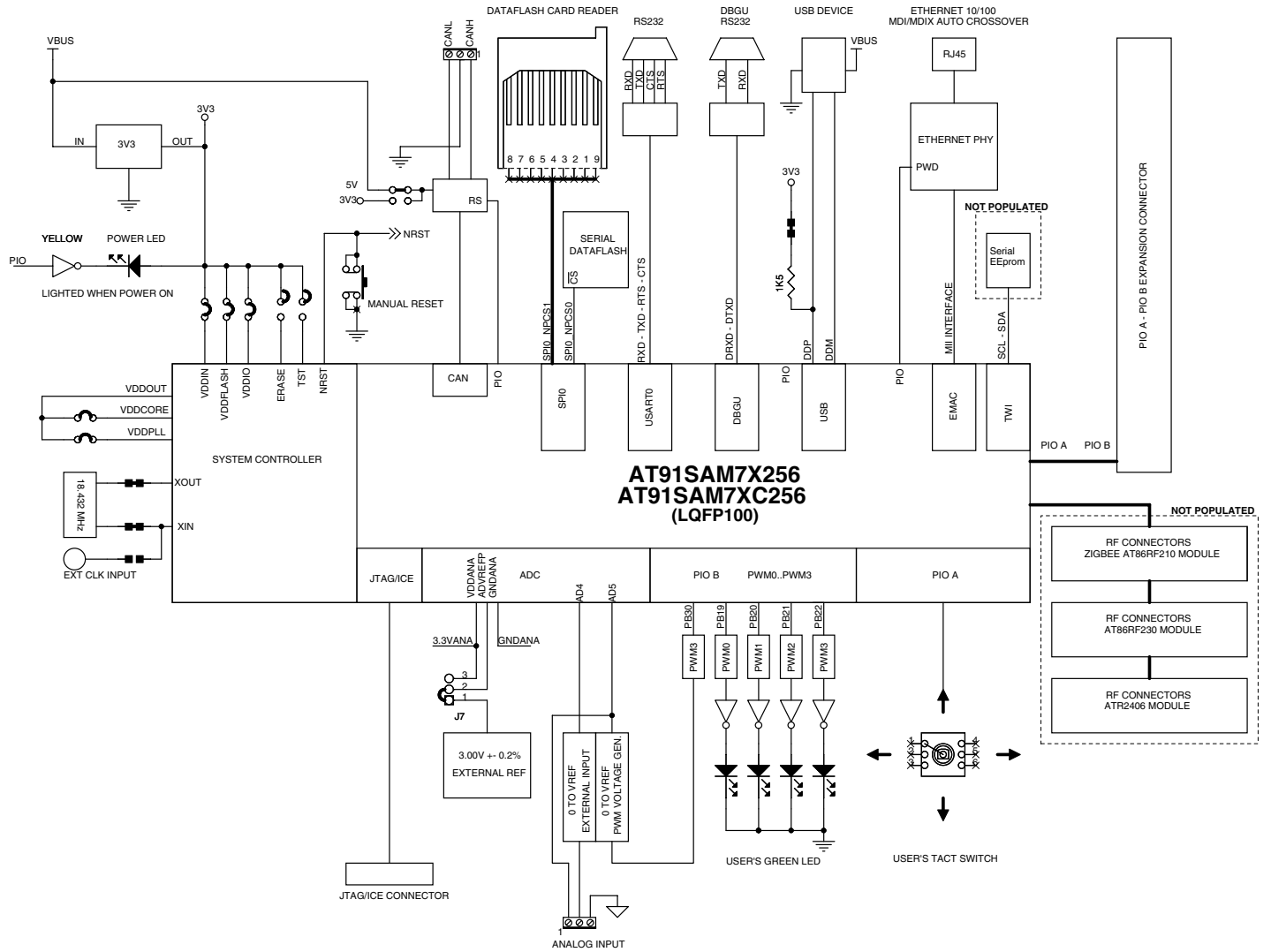



## Section 3

# Board Description

- 3.1 AT91SAM7X Microcontroller**
- Incorporates the ARM7TDMI® ARM® Thumb® Processor
    - High-performance 32-bit RISC Architecture
    - High-density 16-bit Instruction Set
    - Leader in MIPS/Watt
    - EmbeddedICE™, Debug Communication Channel Support
  - Internal High-speed Flash
    - 256 Kbytes (AT91SAM7X256) Organized in 1024 Pages of 256 Bytes
    - 128 Kbytes (AT91SAM7X128) Organized in 512 Pages of 256 Bytes
      - Single Cycle Access at Up to 30 MHz in Worst Case Conditions
      - Prefetch Buffer Optimizing Thumb Instruction Execution at Maximum Speed
    - Page Programming Time: 6 ms, Including Page Auto-erase, Full Erase Time: 15 ms
    - 10,000 Write Cycles, 10-year Data Retention Capability, Sector Lock Capabilities, Flash Security Bit
    - Fast Flash Programming Interface for High Volume Production
  - Internal High-speed SRAM, Single-cycle Access at Maximum Speed
    - 64 Kbytes (AT91SAM7X256)
    - 32 Kbytes (AT91SAM7X128)
  - Memory Controller (MC)
    - Embedded Flash Controller, Abort Status and Misalignment Detection
  - Reset Controller (RSTC)
    - Based on Power-on Reset Cells and Low-power Factory-calibrated Brownout Detector
    - Provides External Reset Signal Shaping and Reset Source Status
  - Clock Generator (CKGR)
    - Low-power RC Oscillator, 3 to 20 MHz On-chip Oscillator and one PLL
  - Power Management Controller (PMC)

- Power Optimization Capabilities, Including Slow Clock Mode (Down to 500 Hz) and Idle Mode
- Four Programmable External Clock Signals
- **Advanced Interrupt Controller (AIC)**
  - Individually Maskable, Eight-level Priority, Vectored Interrupt Sources
  - Two External Interrupt Sources and One Fast Interrupt Source, Spurious Interrupt Protected
- **Debug Unit (DBGU)**
  - 2-wire UART and Support for Debug Communication Channel interrupt, Programmable ICE Access Prevention
- **Periodic Interval Timer (PIT)**
  - 20-bit Programmable Counter plus 12-bit Interval Counter
- **Windowed Watchdog (WDT)**
  - 12-bit key-protected Programmable Counter
  - Provides Reset or Interrupt Signals to the System
  - Counter May Be Stopped While the Processor is in Debug State or in Idle Mode
- **Real-time Timer (RTT)**
  - 32-bit Free-running Counter with Alarm
  - Runs Off the Internal RC Oscillator
- **Two Parallel Input/Output Controllers (PIO)**
  - Sixty-two Programmable I/O Lines Multiplexed with up to Two Peripheral I/Os
  - Input Change Interrupt Capability on Each I/O Line
  - Individually Programmable Open-drain, Pull-up Resistor and Synchronous Output
- **Thirteen Peripheral DMA Controller (PDC) Channels**
- **One USB 2.0 Full Speed (12 Mbits per second) Device Port**
  - On-chip Transceiver, 1352-byte Configurable Integrated FIFOs
- **One Ethernet MAC 10/100 base-T**
  - Media Independent Interface (MII) or Reduced Media Independent Interface (RMII)
  - Integrated 28-byte FIFOs and Dedicated DMA Channels for Transmit and Receive
- **One Part 2.0A and Part 2.0B Compliant CAN Controller**
  - Eight Fully-programmable Message Object Mailboxes, 16-bit Time Stamp Counter
- **One Synchronous Serial Controller (SSC)**
  - Independent Clock and Frame Sync Signals for Each Receiver and Transmitter
  - I<sup>2</sup>S Analog Interface Support, Time Division Multiplex Support
  - High-speed Continuous Data Stream Capabilities with 32-bit Data Transfer

- Two Universal Synchronous/Asynchronous Receiver Transmitters (USART)
  - Individual Baud Rate Generator, IrDA® Infrared Modulation/Demodulation
  - Support for ISO7816 T0/T1 Smart Card, Hardware Handshaking, RS485 Support
  - Full Modem Line Support on USART1
- Two Master/Slave Serial Peripheral Interfaces (SPI)
  - 8- to 16-bit Programmable Data Length, Four External Peripheral Chip Selects
- One Three-channel 16-bit Timer/Counter (TC)
  - Three External Clock Inputs, Two Multi-purpose I/O Pins per Channel
  - Double PWM Generation, Capture/Waveform Mode, Up/Down Capability
- One Four-channel 16-bit Power Width Modulation Controller (PWMC)
- One Two-wire Interface (TWI)
  - Master Mode Support Only, All Two-wire Atmel EEPROMs Supported
- One 8-channel 10-bit Analog-to-Digital Converter, Four Channels Multiplexed with Digital I/Os
- SAM-BA™ Boot Assistance
  - Default Boot program
  - Interface with SAM-BA Graphic User Interface
- IEEE® 1149.1 JTAG Boundary Scan on All Digital Pins
- 5V-tolerant I/Os, Including Four High-current Drive I/O lines, Up to 16 mA Each
- Power Supplies
  - Embedded 1.8V Regulator, Drawing up to 100 mA for the Core and External Components
  - 3.3V VDDIO I/O Lines Power Supply, Independent 3.3V VDDFLASH Flash Power Supply
  - 1.8V VDDCORE Core Power Supply with Brownout Detector
- Fully Static Operation: Up to 55 MHz at 1.65V and 85° C Worst Case Conditions
- Available in a 100-lead LQFP Green Package

### 3.2 AT91SAM7X Block Diagram

Figure 3-1. Block Diagram

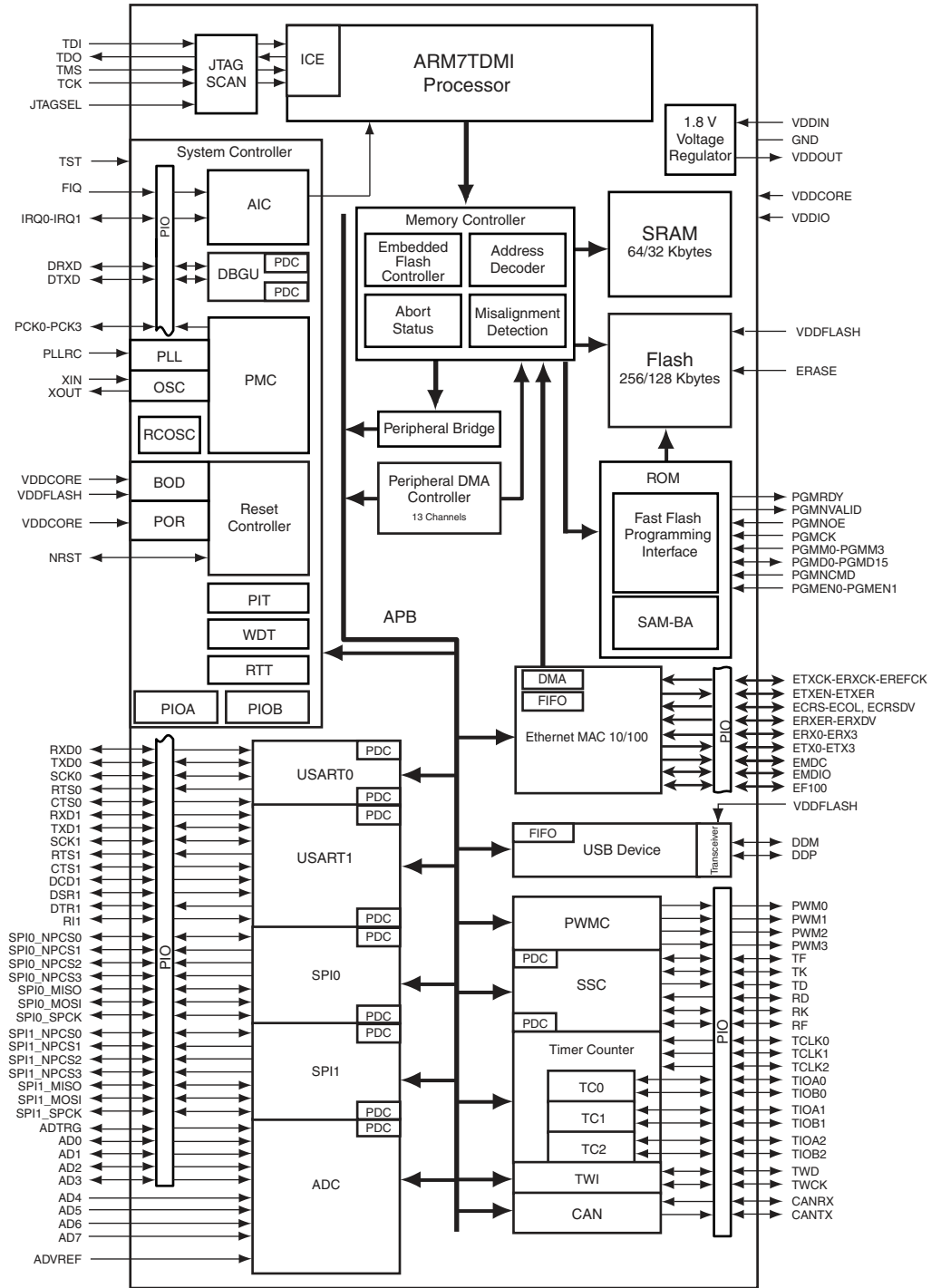

### 3.3 AT91SAM7XC Microcontroller

- Incorporates the ARM7TDMI® ARM® Thumb® Processor
  - High-performance 32-bit RISC Architecture
  - High-density 16-bit Instruction Set
  - Leader in MIPS/Watt
  - EmbeddedICE™, Debug Communication Channel Support
- Internal High-speed Flash
  - 256 Kbytes (AT91SAM7XC256) Organized in 1024 Pages of 256 Bytes
  - 128 Kbytes (AT91SAM7XC128) Organized in 512 Pages of 256 Bytes
    - Single Cycle Access at Up to 30 MHz in Worst Case Conditions
    - Prefetch Buffer Optimizing Thumb Instruction Execution at Maximum Speed
  - Page Programming Time: 6 ms, Including Page Auto-erase, Full Erase Time: 15 ms
  - 10,000 Write Cycles, 10-year Data Retention Capability, Sector Lock Capabilities, Flash Security Bit
  - Fast Flash Programming Interface for High Volume Production
- Internal High-speed SRAM, Single-cycle Access at Maximum Speed
  - 64 Kbytes (AT91SAM7XC256)
  - 32 Kbytes (AT91SAM7XC128)
- Memory Controller (MC)
  - Embedded Flash Controller, Abort Status and Misalignment Detection
- Reset Controller (RSTC)
  - Based on Power-on Reset Cells and Low-power Factory-calibrated Brownout Detector
  - Provides External Reset Signal Shaping and Reset Source Status
- Clock Generator (CKGR)
  - Low-power RC Oscillator, 3 to 20 MHz On-chip Oscillator and one PLL
- Power Management Controller (PMC)
  - Power Optimization Capabilities, Including Slow Clock Mode (Down to 500 Hz) and Idle Mode
  - Four Programmable External Clock Signals
- Advanced Interrupt Controller (AIC)
  - Individually Maskable, Eight-level Priority, Vectored Interrupt Sources
  - Two External Interrupt Sources and One Fast Interrupt Source, Spurious Interrupt Protected
- Debug Unit (DBGU)
  - 2-wire UART and Support for Debug Communication Channel interrupt, Programmable ICE Access Prevention
- Periodic Interval Timer (PIT)
  - 20-bit Programmable Counter plus 12-bit Interval Counter
- Windowed Watchdog (WDT)

- 12-bit key-protected Programmable Counter
- Provides Reset or Interrupt Signals to the System
- Counter May Be Stopped While the Processor is in Debug State or in Idle Mode
- Real-time Timer (RTT)
  - 32-bit Free-running Counter with Alarm
  - Runs Off the Internal RC Oscillator
- Two Parallel Input/Output Controllers (PIO)
  - Sixty-two Programmable I/O Lines Multiplexed with up to Two Peripheral I/Os
  - Input Change Interrupt Capability on Each I/O Line
  - Individually Programmable Open-drain, Pull-up Resistor and Synchronous Output
- Seventeen Peripheral DMA Controller (PDC) Channels
- One Advanced Encryption System (AES)
  - 128-bit Key Algorithm, Compliant with FIPS PUB 197 Specifications
  - Buffer Encryption/Decryption Capabilities with PDC
- One Triple Data Encryption System (TDES)
  - Two-key or Three-key Algorithms, Compliant with FIPS PUB 46-3 Specifications
  - Optimized for Triple Data Encryption Capability
- One USB 2.0 Full Speed (12 Mbits per second) Device Port
  - On-chip Transceiver, 1352-byte Configurable Integrated FIFOs
- One Ethernet MAC 10/100 base-T
  - Media Independent Interface (MII) or Reduced Media Independent Interface (RMII)
  - Integrated 28-byte FIFOs and Dedicated DMA Channels for Transmit and Receive
- One Part 2.0A and Part 2.0B Compliant CAN Controller
  - Eight Fully-programmable Message Object Mailboxes, 16-bit Time Stamp Counter
- One Synchronous Serial Controller (SSC)
  - Independent Clock and Frame Sync Signals for Each Receiver and Transmitter
  - I<sup>2</sup>S Analog Interface Support, Time Division Multiplex Support
  - High-speed Continuous Data Stream Capabilities with 32-bit Data Transfer
- Two Universal Synchronous/Asynchronous Receiver Transmitters (USART)
  - Individual Baud Rate Generator, IrDA<sup>®</sup> Infrared Modulation/Demodulation
  - Support for ISO7816 T0/T1 Smart Card, Hardware Handshaking, RS485 Support
  - Full Modem Line Support on USART1
- Two Master/Slave Serial Peripheral Interfaces (SPI)



- 8- to 16-bit Programmable Data Length, Four External Peripheral Chip Selects
- One Three-channel 16-bit Timer/Counter (TC)
  - Three External Clock Inputs, Two Multi-purpose I/O Pins per Channel
  - Double PWM Generation, Capture/Waveform Mode, Up/Down Capability
- One Four-channel 16-bit Power Width Modulation Controller (PWMC)
- One Two-wire Interface (TWI)
  - Master Mode Support Only, All Two-wire Atmel EEPROMs Supported
- One 8-channel 10-bit Analog-to-Digital Converter, Four Channels Multiplexed with Digital I/Os
- SAM-BA™ Boot Assistance
  - Default Boot program
  - Interface with SAM-BA Graphic User Interface
- IEEE® 1149.1 JTAG Boundary Scan on All Digital Pins
- 5V-tolerant I/Os, Including Four High-current Drive I/O lines, Up to 16 mA Each
- Power Supplies
  - Embedded 1.8V Regulator, Drawing up to 100 mA for the Core and External Components
  - 3.3V VDDIO I/O Lines Power Supply, Independent 3.3V VDDFLASH Flash Power Supply
  - 1.8V VDDCORE Core Power Supply with Brownout Detector
- Fully Static Operation: Up to 55 MHz at 1.65V and 85° C Worst Case Conditions
- Available in a 100-lead LQFP Green Package

### 3.4 AT91SAM7XC Export Regulations Statement

These commodities, technology or software will be exported from France and the applicable Export Administration Regulations will apply. French, United States and other relevant laws, regulations and requirements regarding the export of products may restrict sale, export and re-export of these products; please assure you conduct your activities in accordance with the applicable relevant export regulations.

### 3.5 AT91SAM7XC Block Diagram

Figure 3-2. Block Diagram

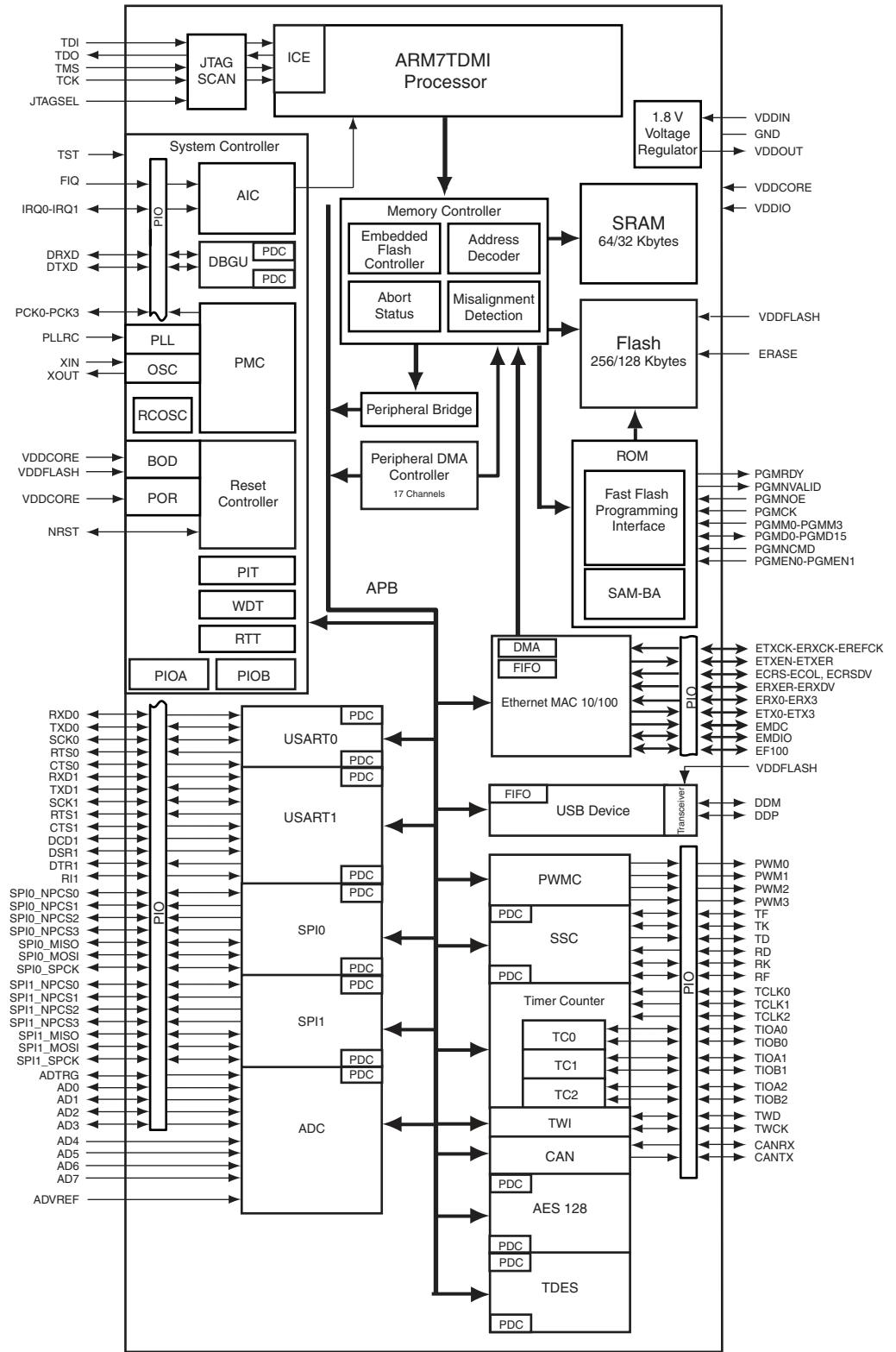

- 
- 3.6 Memory**
- 256 Kbytes of Internal High-speed Flash
  - 64 Kbytes of Internal High-speed SRAM
  - Atmel serial DataFlash®
  - One footprint for Atmel Serial EEPROM memory. The user can fit an AT24C128AN or AT24C256AN or AT24C512AN in 8S1 package as well as a cryptomemory AT88C25616C-SI
- 
- 3.7 Clock Circuitry**
- 18.432 MHz standard crystal for the embedded oscillator
  - 32 KHz internal RC oscillator
- 
- 3.8 Reset Circuitry**
- Internal reset controller with a bidirectional reset pin
  - External reset pushbutton
- 
- 3.9 Power Supply Circuitry**
- USB powered, the dynamic power consumption on VDDCORE is less than 90 mA at full speed when running out of the Flash. The total current at power-up is less than 100 mA.
  - External power can be applied via USB Power adapter 5V 0.5A with USB A/B cable
  - On-chip embedded VDDCORE 1.8V regulator
  - On-board 3.3V 400 mA linear regulator
- 
- 3.10 Remote Communication**
- One Serial interface (DBGU COM Port) via RS-232 DB9 male socket
  - One Serial interface (RS232 COM Port) via RS-232 DB9 male socket
  - USB V2.0 Full-speed compliant, 12 Mbits per second (UDP)
  - One CAN 2.0B communication port via the 3-position printed circuit terminal block
  - One MII Ethernet 100-base TX (auto MDI/MDI-X crossover cable)
- 
- 3.11 Analog Interface**
- One selectable 0.2% 3.00V Vref or 3.3V ANA
  - One 3-position printed circuit terminal block
  - Two analog up to Vref inputs. One external user input and one back-looped with buffered PWM3 output.
  - One buffered PWM3 analog output (up to Vref)
- 
- 3.12 User Interface**
- One 5-way joystick (4 directions and push for confirmation)
  - Four general-purpose buffered green user LEDs (PWM controlled)

- One yellow power LED (can also be software controlled)

- 
- 3.13 Debug Interface**
- 20-pin JTAG/ICE interface connector
  - DBGU serial RS232 COM Port

- 
- 3.14 Expansion Slot**
- One DataFlash card slot
  - All I/Os of the AT91SAM7X and the AT91SAM7XC are routed to peripheral extension connectors (J16). This allows the developer to check the integrity of the components and to extend the features of the board by adding external hardware components or boards.



## Section 4

# Configuration Straps

### 4.1 Configuration Straps

**Table 4-1.** Configuration Jumpers and Straps

Designation	Default Setting	Feature
J8	Opened	Erases all internal Flash memory when the board is powered. To do that, the user will have to close the J8 at least 200 ms.
J9	Opened	Do not use: Factory test mode. J9 is not populated
J10	Opened	Selects ICE mode or JTAG mode (Closed). J10 is not populated.
J11	Closed	VDDIN Jumper <sup>(1)</sup>
J12	Closed	VDDFLASH Jumper <sup>(1)</sup>
J13	1-2	ADVREF Jumper select 1-2: 3.00V Voltage reference 2-3: VDDANA
J14	Closed	VDDCORE Jumper <sup>(1)</sup>
J15	Closed	VDDIO Jumper <sup>(1)</sup>
J17	Opened	External XIN clock input. <b>S4 and S5 must be open.</b> J17 is not populated.
J18	Closed	VDDPLL Jumper <sup>(1)</sup>
J19	Closed	Enables the use of the NPC500 (PA12).
J21	Closed	Enables 120 ohms CAN bus resistance termination.
J28	Closed	Enables Ethernet Auto MDIX control.
S1	Closed	Enables permanent pull up on USB DP.
S2	Closed	The System Reset signal (NRST) is connected to the ICE/JTAG socket (J7, pin 15).
S3	Opened	Disables 5V (VUSB) power supply on J16 extension connector.

**Table 4-1.** Configuration Jumpers and Straps (Continued)

Designation	Default Setting	Feature
S4 - S5	Closed	Enables the use of 18.432MHz crystal. Must be open if an external clock is used.
S6	Closed	Enables the Power Led control (PB25).
S7	Opened	Disables Serial DataFlash write protect.
S8	Closed	Enables the use of the TXD CAN transceiver (PA20)
S9	Closed	Enables the use of the RXD CAN transceiver (PA19)
S10	Closed	Enables control of the Standby/Normal mode for CAN transceivers (PA2)
S11	Opened	Enables control of the Standby/Normal mode for CAN transceivers (PA2). <b>If S11 is closed, S10 must be open.</b>
S12	Closed	Enables the use of PWM3 Analog Output (PB30)
S13	Closed	Enables the use of the TXD0 signal (PA1)
S14	Closed	Enables the use of the RTS0 signal (PA3)
S15	Closed	Enables the use of the RXD0 signal (PA0)
S16	Closed	Enables the use of the CTS0 signal (PA4)
S17	Closed	Enables the use of the User LED DS1 (PB19)
S18	Closed	Enables the use of the User LED DS2 (PB20)
S19	Closed	Enables the use of the User LED DS3 (PB21)
S20	Closed	Enables the use of the User LED DS4 (PB22)
S21	Closed	Enables the use of the DBGU TXD signal (PA28)
S22	Closed	Enables the use of the DBGU RXD signal (PA27)
S23	Opened	ETHERNET MII is the default mode. To evaluate the RMII mode, the user change S23 to S26 configuration in the following way: S23 Closed, S24 Opened, S25 Closed, S26 Opened
S24	Closed	
S25	Opened	
S26	Closed	
S27	Opened	Reserved
S28	Closed	Enables the use of the SCL of MN11 (PA11)
S29	Closed	Enables the use of the SDA of MN11 (PA10)
TP1	N.A	GND Test point.
TP2	N.A	GND Test point.

Note: 1. These jumpers are provided for measuring power consumption. By default, they are closed. To use this feature, the user has to open the strap and insert an ammeter.



## Section 5

---

# Schematics

- 
- 5.1 Schematics** This section contains the following schematics:
- Processor Board
  - I/O
  - Ethernet
  - RF modules

**USB DEVICE INTERFACE**

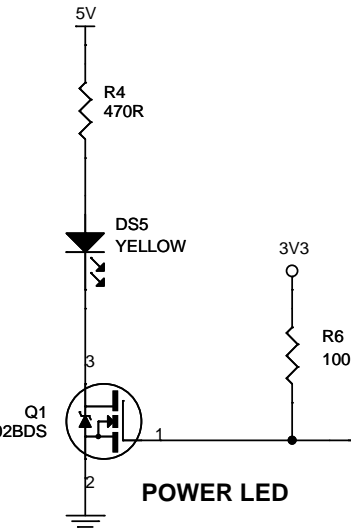
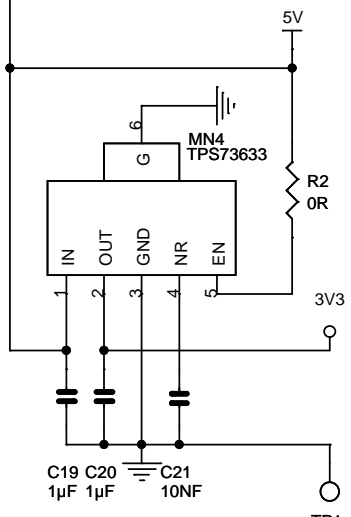
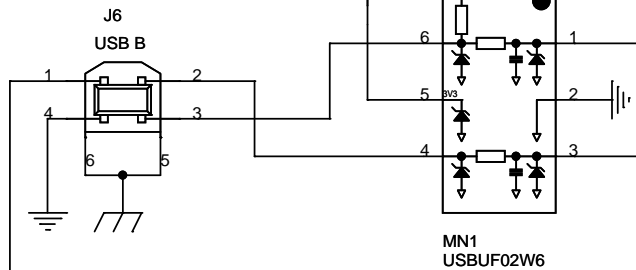

**JTAG INTERFACE**

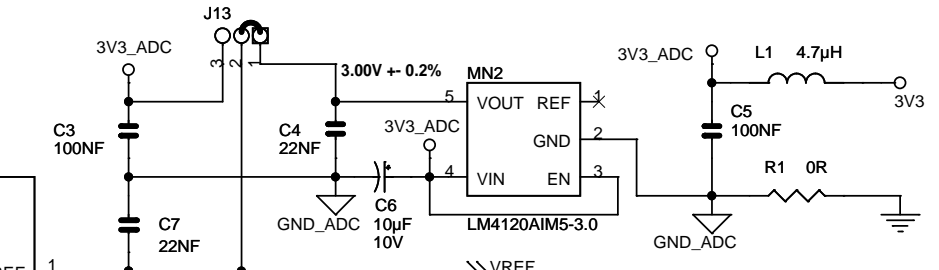
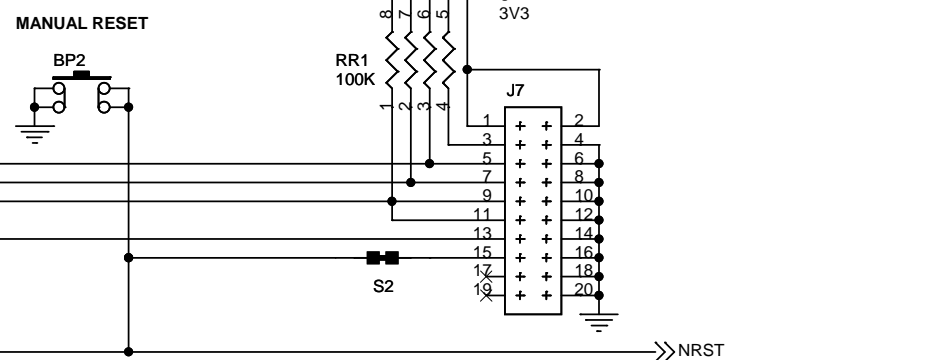

**AT91SAM7X256  
AT91SAM7XC256**

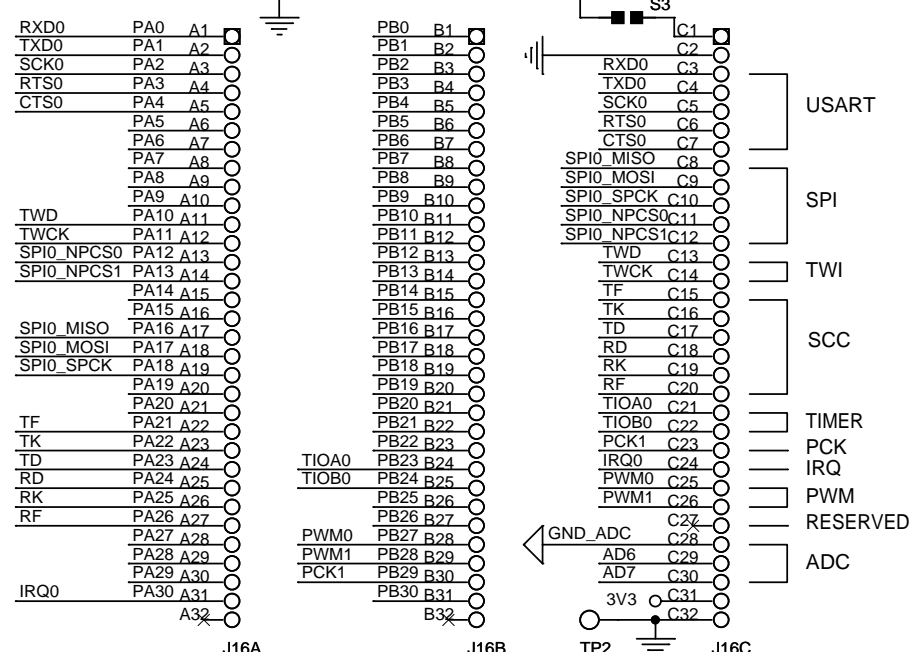
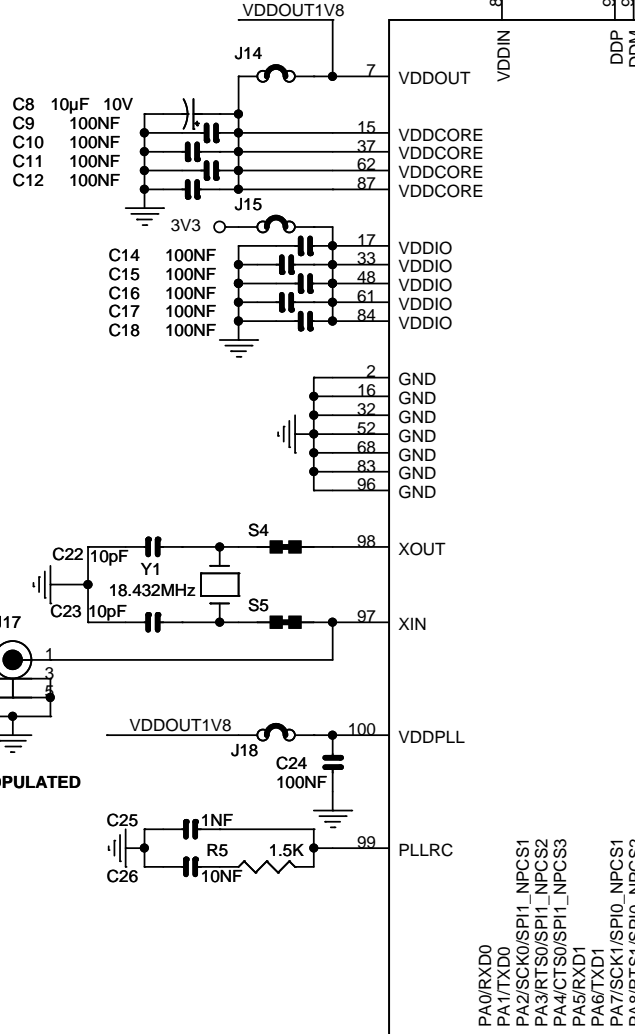

**DATAFLASH CARD SOCKET**

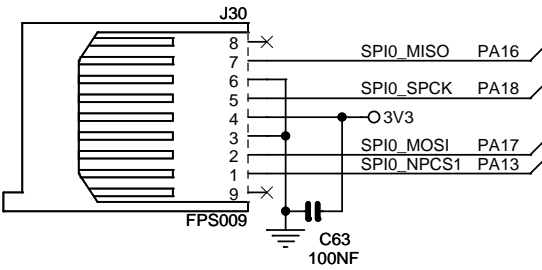

**DATAFLASH MEMORY**

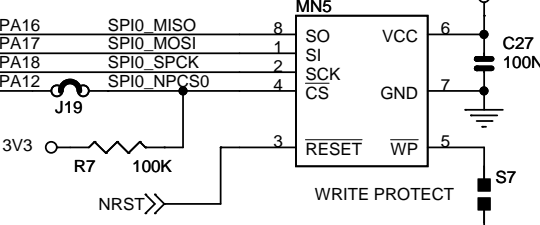

**SERIAL EEPROM**

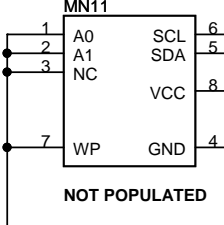

C	JPG	14/12/05		
B	JPG	30/09/05		
A	INIT EDIT	JPG	13/09/05	
REV	MODIF.	DES.	DATE	VER.
SCALE	1/1			
AT91SAM7X-EK AT91SAM7XC-EK PROCESSOR BOARD				REV. SHEET C 1/4

This agreement is our property. Reproduction and publication without our written authorization shall expose offender to legal proceedings.



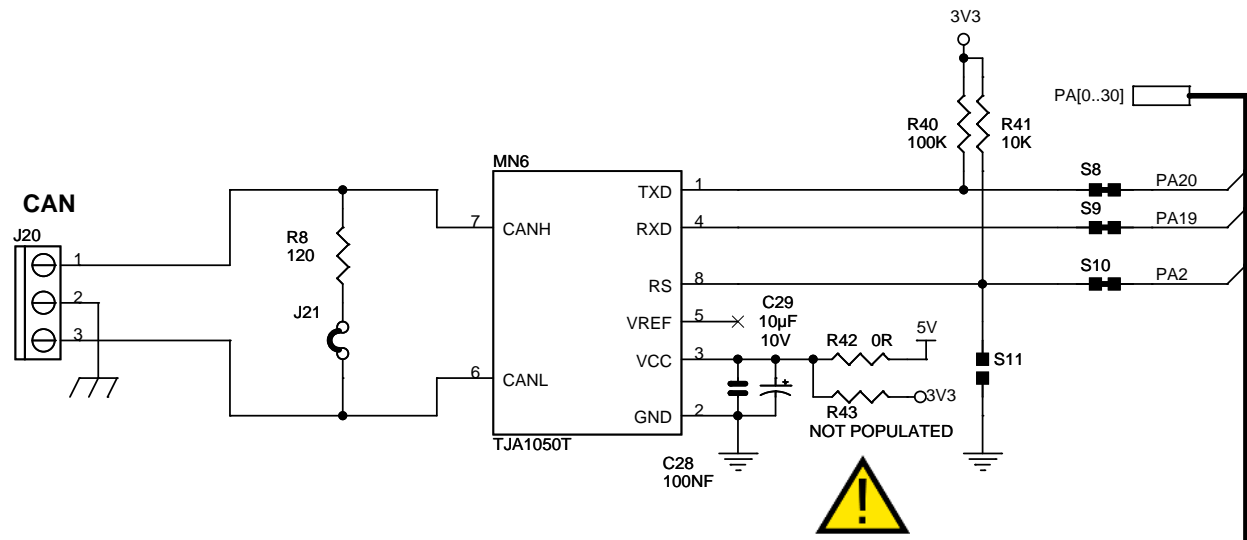

**RS232 COM PORT**

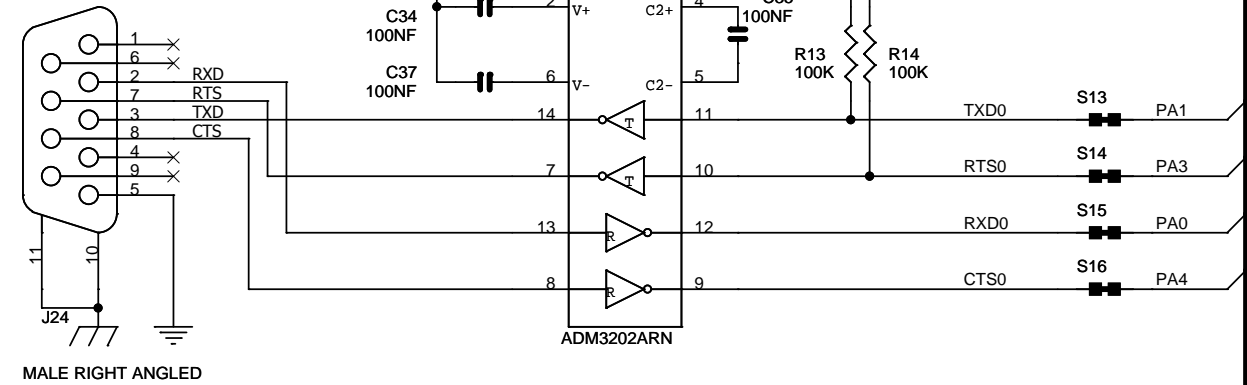

MALE RIGHT ANGLED

**SERIAL DEBUG PORT**

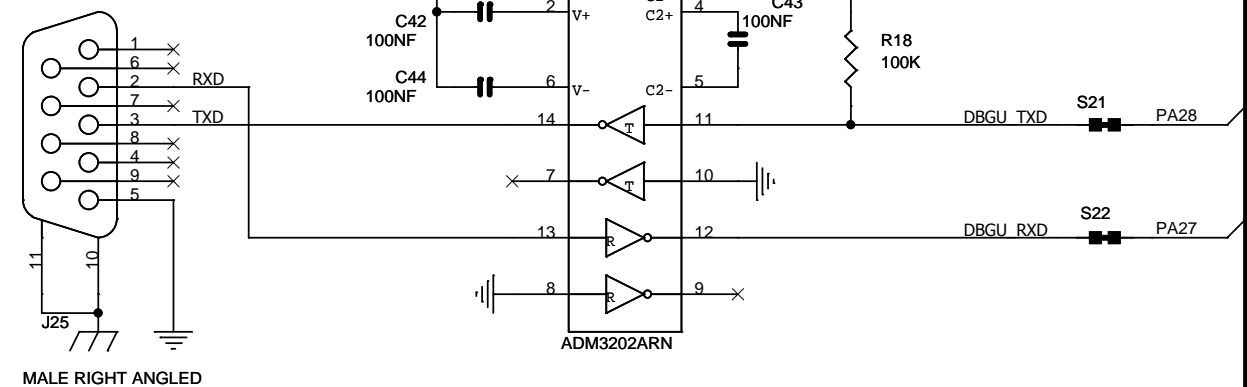

MALE RIGHT ANGLED

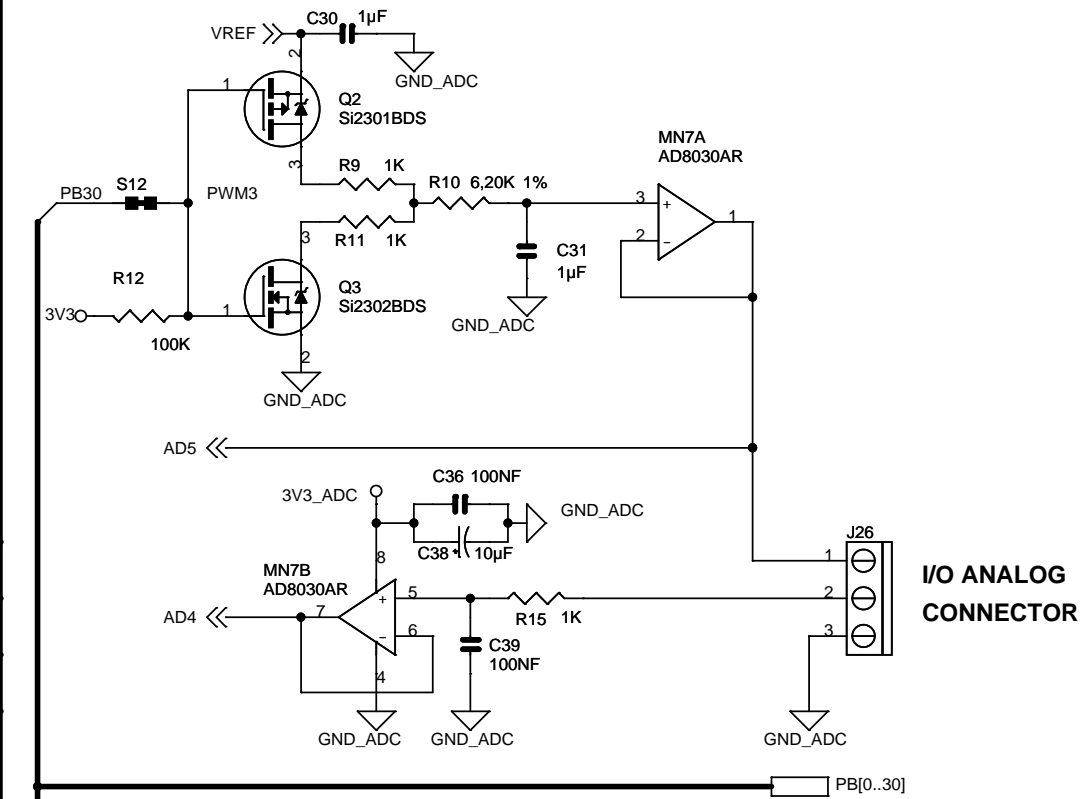

**I/O ANALOG CONNECTOR**

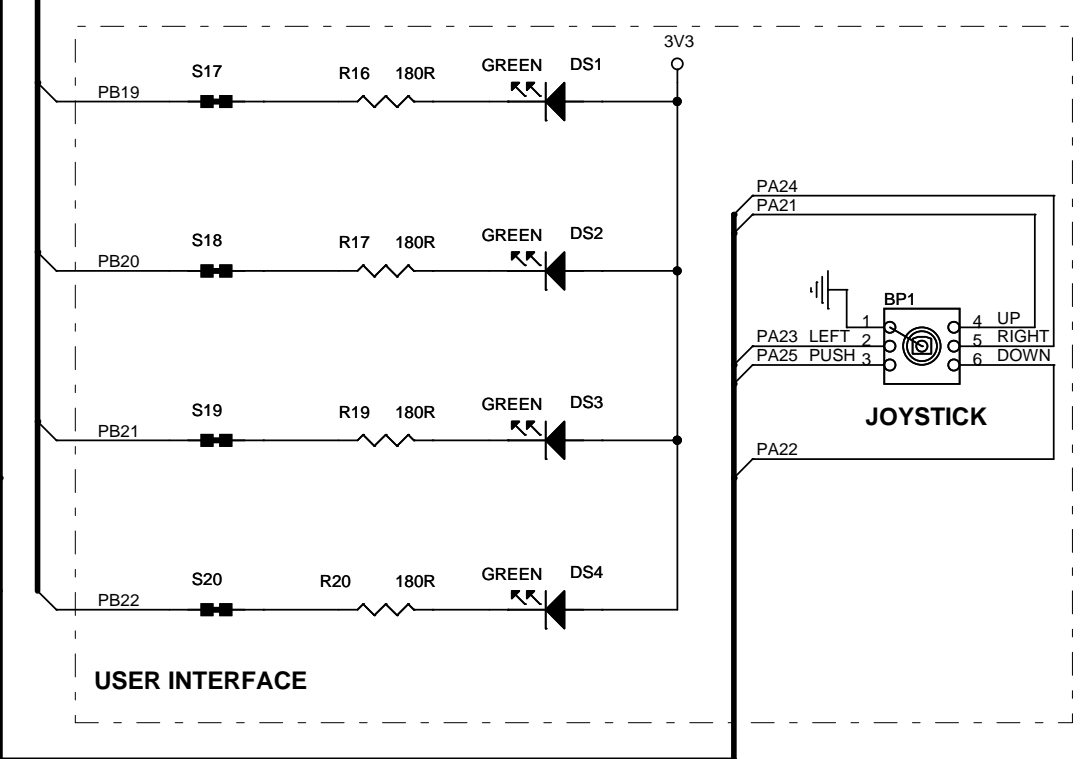

**USER INTERFACE**

C	JPG	14/12/05				
B	JPG	30/09/05				
A	INIT EDIT	JPG	13/09/05			
REV	MODIF.	DES.	DATE	VER.	DATE	
SCALE	1/1					
I/O						
				<b>C</b>	<b>2/4</b>	
This agreement is our property. Reproduction and publication without our written authorization shall expose offender to legal proceedings.						

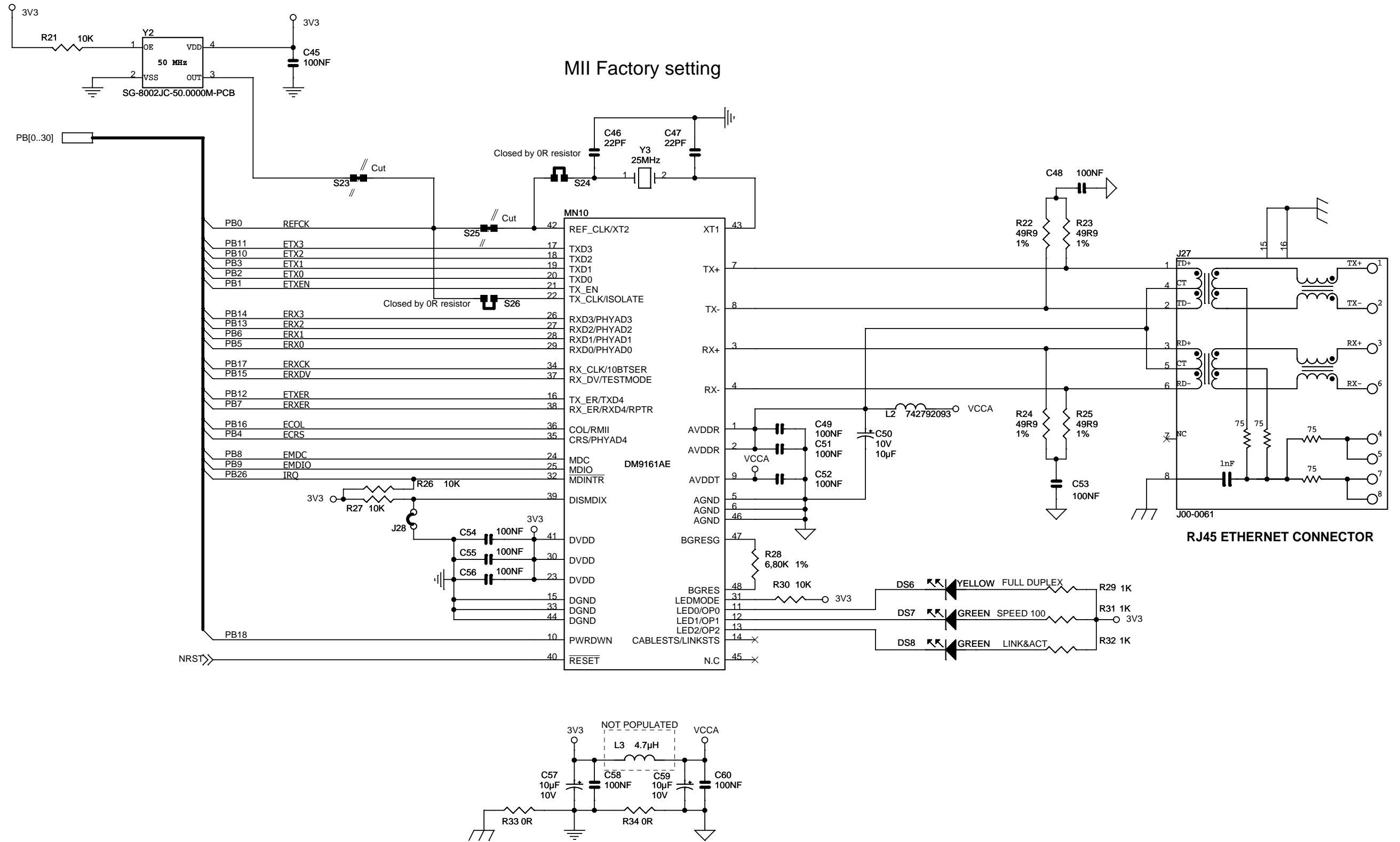

<b>ATMEL</b>					
ROUSSET					
C	JPG	14/12/05			
B	JPG	30/09/05			
A	INIT EDIT	JPG	13/09/05		
REV	MODIF.	DES.	DATE	VER.	DATE
SCALE	1/1			REV.	SHEET
				C	3/4

AT91SAM7X-EK  
AT91SAM7XC-EK  
ETHERNET

This agreement is our property. Reproduction and publication without our written authorization shall expose offender to legal proceedings.

**ATR2406 2.4 GHz RF CONNECTORS MODULE**

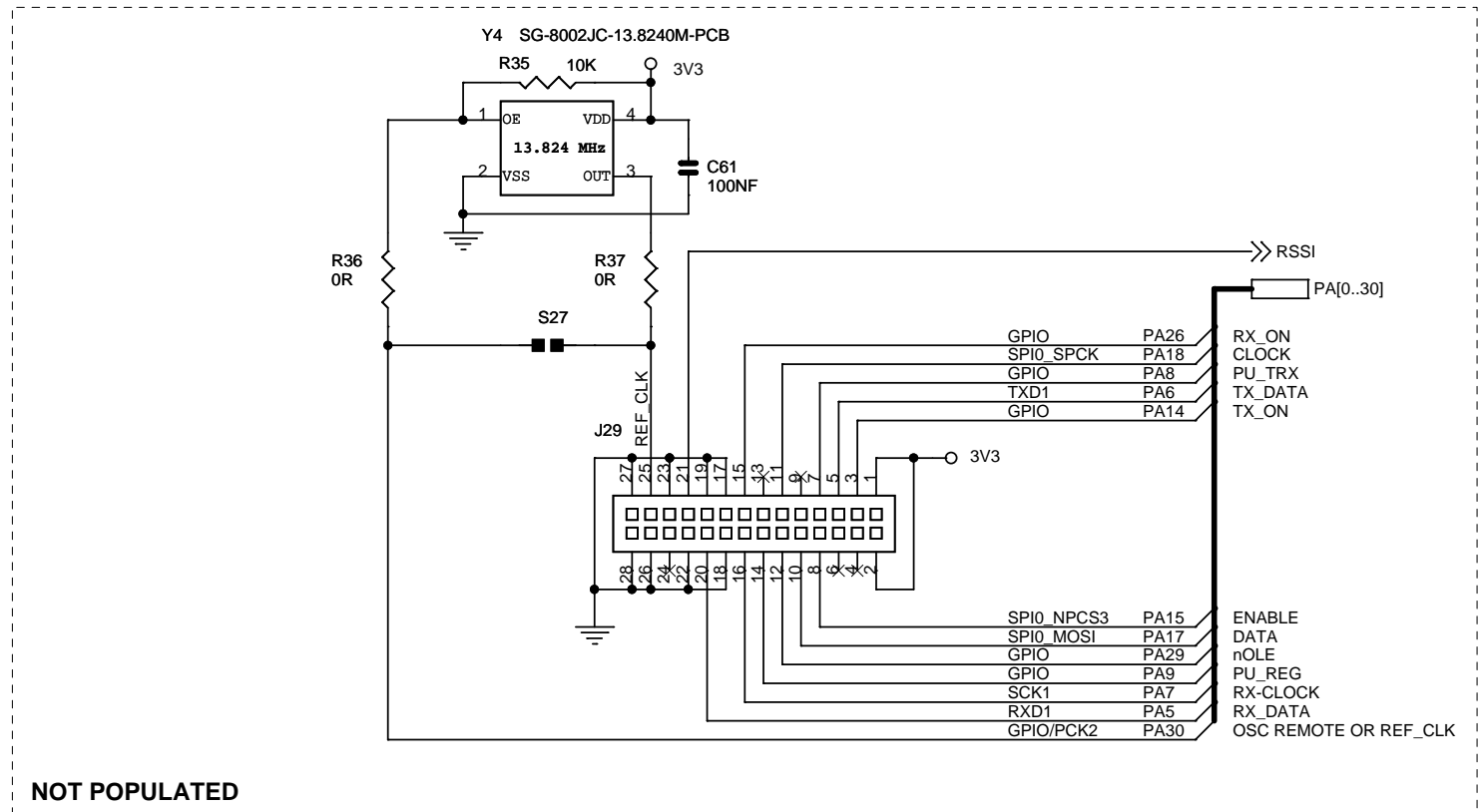

**AT86RF210 ZIGBEE CONNECTORS MODULE**

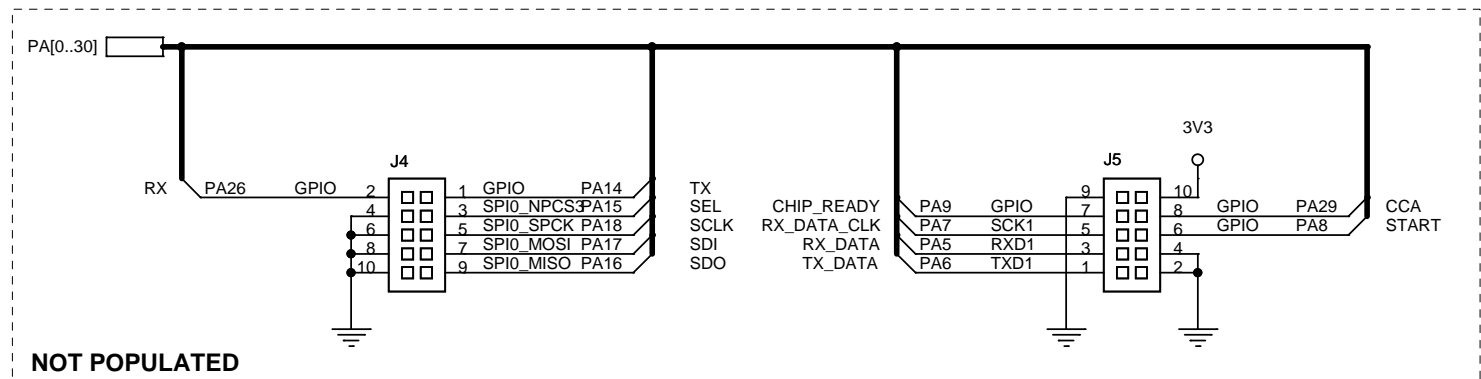

**AT86RF230 CONNECTORS MODULE**

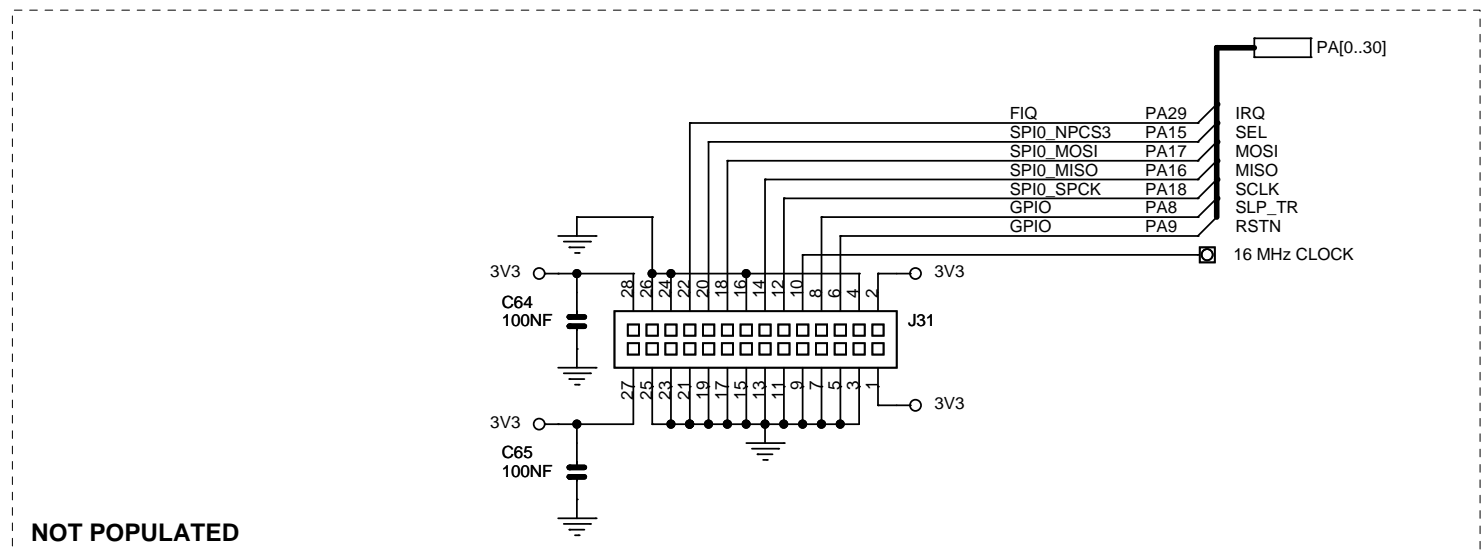

**USER'S GRID AERA**

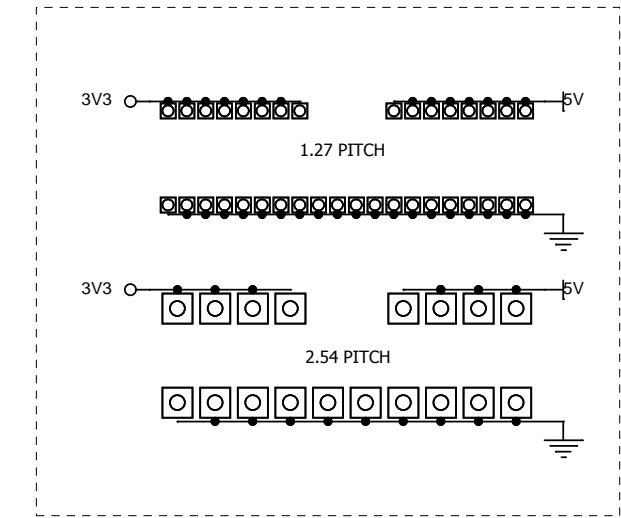

<b>ATMEL</b>						
ROUSSET						
AT91SAM7X-EK						
AT91SAM7XC-EK						
RF MODULES						
REV. A	INIT EDIT	JPG	14/12/05			
REV. B	MODIF.	JPG	30/09/05			
REV. C	DES.	JPG	13/09/05			
SCALE 1/1				VER. C	DATE 4/4	
This agreement is our property. Reproduction and publication without our written authorization shall expose offender to legal proceedings.						





## Section 6

---

### Errata

- 
- 6.1 DM9161A Ethernet Phy Connections**
- The Ethernet interface works as presented in the schematics, but the connections are not in compliance with Davicom recommendations.
- To comply with Davicom recommendations on connecting this device, J27-4 and J27-5 (RJ45 connector, CT) should be connected to the VCCA side of L2. In the current schematics (ETHERNET, Sheet 3/4), the VCCA side of L2 is connected to MN10-1 and MN10-2 (DM9161A, AVDDR).
- For additional information, refer to the Davicom datasheet for DM9161A and associated Application Notes available on <http://www.davicom.com.tw/>.
- 
- 6.2 TWI line pullups for Fast Mode operation**
- In order to use the TWI in Fast Mode (up to 400 Kbits/s), the default 10 K $\Omega$  resistors R38 and R39 should be replaced by smaller values (e.g., 2.2 K $\Omega$ ).
- Note that there is no need to change the pull-up resistors if the TWI is used in Standard Mode (up to 100 Kbits/s).





## Section 7

# Revision History

### 7.1 Revision History

**Table 7-1.** Change History

Document	Comments	Change Request Ref.
6195A	First issue.	
6195B	Updated <a href="#">Figure 2-3</a> with new signal names. Updated document to show new product functionalities. New board block diagram and schematics issued.	05-430
6195C	Updated document to contain new product AT91SAM7XC. Added new section with Errata.	
6195D	Removed references to 32 Mbit serial DataFlash (AT45DB321C-CNC) in <a href="#">Section 1.3</a> and in <a href="#">Section 3.6</a> . Inserted new <a href="#">Figure 2-3</a> and new schematics in <a href="#">Section 5</a> .	2862
6195E	Added Errata <a href="#">Section 6.2 "TWI line pullups for Fast Mode operation"</a>	4084







## Atmel Corporation

2325 Orchard Parkway  
San Jose, CA 95131, USA  
Tel: 1(408) 441-0311  
Fax: 1(408) 487-2600

## Regional Headquarters

### Atmel Europe

Le Krebs  
8, rue Jean-Pierre Timbaud  
BP 309  
78054 Saint-Quentin-en-Yvelines  
Cedex  
France  
Tel: (33) 1-30-60-70-00  
Fax: (33) 1-30-60-71-11

### Asia

Room 1219  
Chinachem Golden Plaza  
77 Mody Road Tsimshatsui  
East Kowloon  
Hong Kong  
Tel: (852) 2721-9778  
Fax: (852) 2722-1369

### Japan

9F, Tonetsu Shinkawa Bldg.  
1-24-8 Shinkawa  
Chuo-ku, Tokyo 104-0033  
Japan  
Tel: (81) 3-3523-3551  
Fax: (81) 3-3523-7581

## Atmel Operations

### Memory

2325 Orchard Parkway  
San Jose, CA 95131, USA  
Tel: 1(408) 441-0311  
Fax: 1(408) 436-4314

### Microcontrollers

2325 Orchard Parkway  
San Jose, CA 95131, USA  
Tel: 1(408) 441-0311  
Fax: 1(408) 436-4314

### La Chantrerie

BP 70602  
44306 Nantes Cedex 3, France  
Tel: (33) 2-40-18-18-18  
Fax: (33) 2-40-18-19-60

### ASIC/ASSP/Smart Cards

Zone Industrielle  
13106 Rousset Cedex, France  
Tel: (33) 4-42-53-60-00  
Fax: (33) 4-42-53-60-01

1150 East Cheyenne Mtn. Blvd.  
Colorado Springs, CO 80906, USA  
Tel: 1(719) 576-3300  
Fax: 1(719) 540-1759

Scottish Enterprise Technology Park  
Maxwell Building  
East Kilbride G75 0QR, Scotland  
Tel: (44) 1355-803-000  
Fax: (44) 1355-242-743

### RF/Automotive

Theresienstrasse 2  
Postfach 3535  
74025 Heilbronn, Germany  
Tel: (49) 71-31-67-0  
Fax: (49) 71-31-67-2340

1150 East Cheyenne Mtn. Blvd.  
Colorado Springs, CO 80906, USA  
Tel: 1(719) 576-3300  
Fax: 1(719) 540-1759

### Biometrics

Avenue de Rochepleine  
BP 123  
38521 Saint-Egreve Cedex, France  
Tel: (33) 4-76-58-47-50  
Fax: (33) 4-76-58-47-60



**Disclaimer:** The information in this document is provided in connection with Atmel products. No license, express or implied, by estoppel or otherwise, to any intellectual property right is granted by this document or in connection with the sale of Atmel products. **EXCEPT AS SET FORTH IN ATMEL'S TERMS AND CONDITIONS OF SALE LOCATED ON ATMEL'S WEB SITE, ATMEL ASSUMES NO LIABILITY WHATSOEVER AND DISCLAIMS ANY EXPRESS, IMPLIED OR STATUTORY WARRANTY RELATING TO ITS PRODUCTS INCLUDING, BUT NOT LIMITED TO, THE IMPLIED WARRANTY OF MERCHANTABILITY, FITNESS FOR A PARTICULAR PURPOSE, OR NON-INFRINGEMENT. IN NO EVENT SHALL ATMEL BE LIABLE FOR ANY DIRECT, INDIRECT, CONSEQUENTIAL, PUNITIVE, SPECIAL OR INCIDENTAL DAMAGES (INCLUDING, WITHOUT LIMITATION, DAMAGES FOR LOSS OF PROFITS, BUSINESS INTERRUPTION, OR LOSS OF INFORMATION) ARISING OUT OF THE USE OR INABILITY TO USE THIS DOCUMENT, EVEN IF ATMEL HAS BEEN ADVISED OF THE POSSIBILITY OF SUCH DAMAGES.** Atmel makes no representations or warranties with respect to the accuracy or completeness of the contents of this document and reserves the right to make changes to specifications and product descriptions at any time without notice. Atmel does not make any commitment to update the information contained herein. Unless specifically provided otherwise, Atmel products are not suitable for, and shall not be used in, automotive applications. Atmel's products are not intended, authorized, or warranted for use as components in applications intended to support or sustain life.

© 2007 Atmel Corporation. All rights reserved. Atmel®, logo and combinations thereof, and Everywhere You Are®, DataFlash® and others are registered trademarks, SAM-BA™ and others are trademarks of Atmel Corporation or its subsidiaries. ARM®, the ARM Powered® logo, ARM7TDMI®, Thumb® and others are the registered trademarks or trademarks of ARM Ltd. Other terms and product names may be trademarks of others.

### Literature Requests

[www.atmel.com/literature](http://www.atmel.com/literature)



Printed on recycled paper.

6195E-ATARM-22-Mar-07