

APPROVAL SHEET



WLSN084F Series
SMD Unshielded Power Inductors

*Contents in this sheet are subject to change without prior notice.

Features

1. Unshielded power inductor.
2. Wide inductance range.

Applications

1. Inductor in DC/DC converter.
2. Use in STB、PDA、Notebook.

Shape and Dimension

Unit: mm

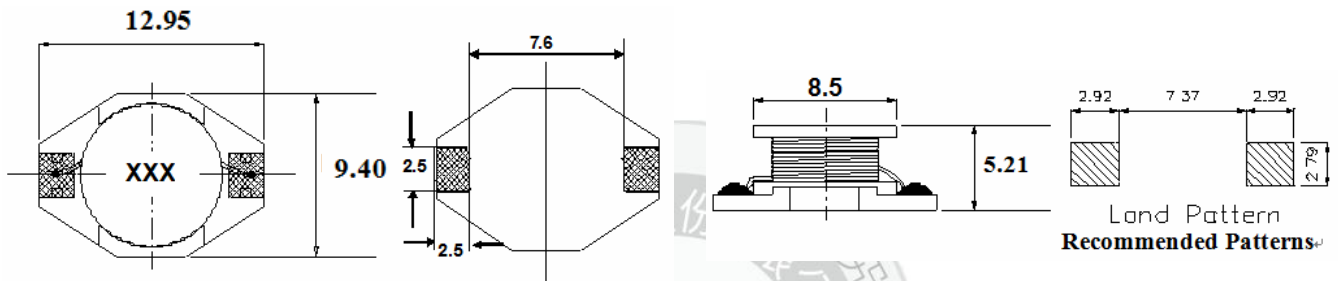

Ordering Information

WL	SN	084F	Z0	M	1R0	L	B
Product Code	Series	Dimensions	Thickness	Tolerance	Value	Packing Code	
WL: Inductor	SMD Unshielded Power Inductors	12.95 * 9.40 mm	Z0: STD	M: ± 20%	1R0 = 1.0uH 100 = 10.0uH	L=13" Reeled (Embossed tape)	B:STD

Electrical Characteristics

WLSN084 Series	Marking	Inductance (uH)	Inductance Tolerance	Test Freq (KHz)	DCR MAX. (Ω)	I Sat (A)	I Rat (A)
WLSN084FZ0M1R0LB	1R0	1.0	± 20%	100	0.009	9.00	6.80
WLSN084FZ0M1R5LB	1R5	1.5	± 20%	100	0.010	8.00	6.40
WLSN084FZ0M2R2LB	2R2	2.2	± 20%	100	0.012	7.00	6.10
WLSN084FZ0M3R3LB	3R3	3.3	± 20%	100	0.015	6.40	5.40
WLSN084FZ0M4R7LB	4R7	4.7	± 20%	100	0.018	5.40	4.80
WLSN084FZ0M6R8LB	6R8	6.8	± 20%	100	0.027	4.60	4.40
WLSN084FZ0M100LB	100	10.0	± 20%	100	0.038	3.80	3.90
WLSN084FZ0M150LB	150	15.0	± 20%	100	0.046	3.00	3.10
WLSN084FZ0M220LB	220	22.0	± 20%	100	0.085	2.60	2.70
WLSN084FZ0M330LB	330	33.0	± 20%	100	0.100	2.00	2.10
WLSN084FZ0M470LB	470	47.0	± 20%	100	0.140	1.60	1.80
WLSN084FZ0M680LB	680	68.0	± 20%	100	0.200	1.40	1.50
WLSN084FZ0M101LB	101	100.0	± 20%	100	0.280	1.20	1.30
WLSN084FZ0M151LB	151	150.0	± 20%	100	0.400	1.00	1.00
WLSN084FZ0M221LB	221	220.0	± 20%	100	0.610	0.80	0.80
WLSN084FZ0M331LB	331	330.0	± 20%	100	1.020	0.60	0.60
WLSN084FZ0M471LB	471	470.0	± 20%	100	1.270	0.50	0.50
WLSN084FZ0M681LB	681	680.0	± 20%	100	2.020	0.40	0.40
WLSN084FZ0M102LB	102	1000.0	± 20%	100	3.000	0.30	0.30
WLSN084FZ0M152LB	152	1500.0	± 20%	100	5.000	0.25	0.25

a. Tolerance : M : ±20%

b. Operating Temp : -25°C to +105°C.

c. Inductance measured using the HP4284A LCR meter, CHROMA3302/1320/16502.

d. DCR measured using the 502BC milli-ohm meter.

e. Inductance drops no more than 10 % of initial value at Isat , temperature rises $\Delta t < 40^{\circ}\text{C}$ at rated current.

※MSL : LEVEL 1

TYPICAL RoHS REFLOW PROFILE

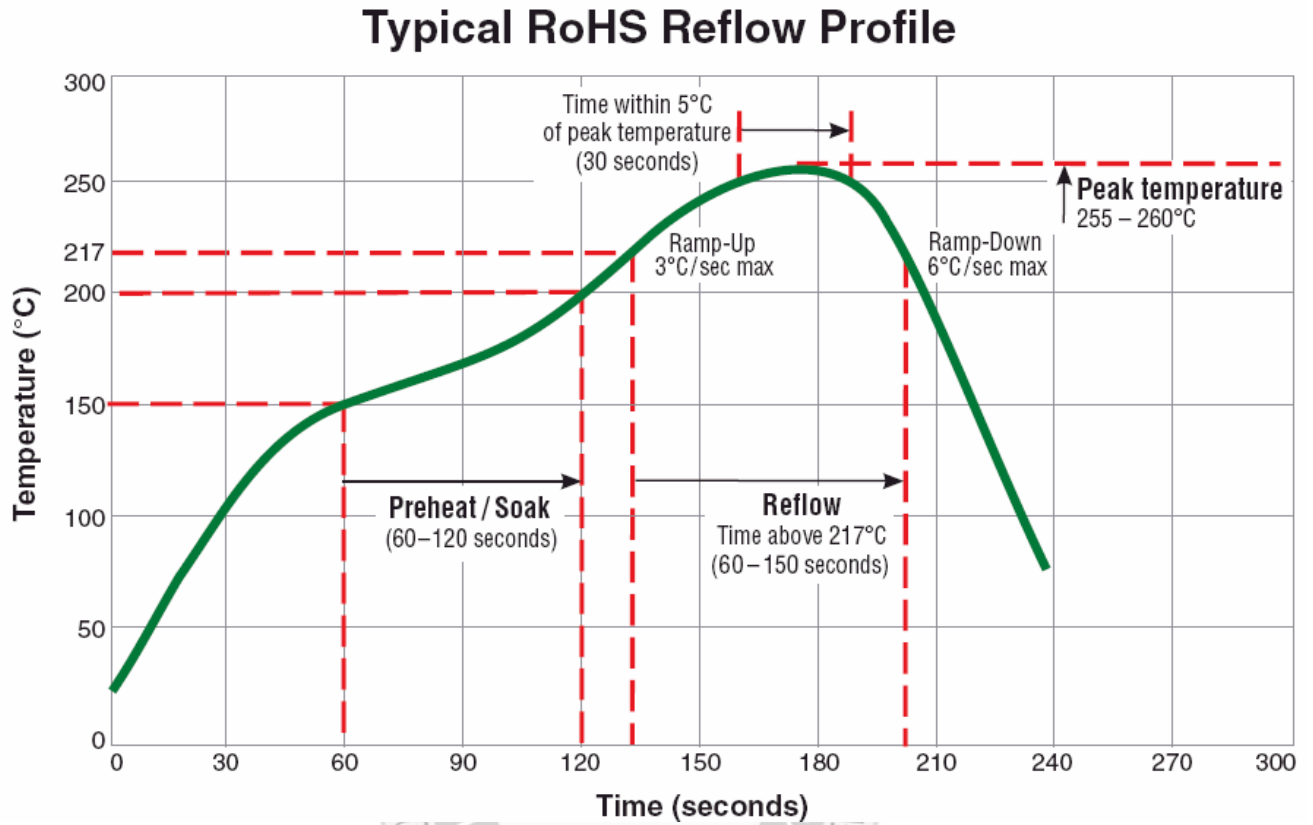

RELIABILITY PERFORMANCE

Reliability Experiment For Electrical

Test Item	Test Condition	Standard Source
Humidity Test	+40°C ± 2°C, humidity of 90% ± 5% (total 96 hours).	MIL-STD-202G Method 103B Test Condition B
High Temperature Test	1. Temperature: +125°C ± 2°C 2. Test time: 48 ± 2hrs	IEC 68-2 Test Condition B
Low Temperature Test	1. Temperature: -40°C ± 2°C 2. Test time: 48 ± 2hrs	IEC 68-2 Test Condition A
Thermal Shock	+125°C ± 5°C (30 minutes) ~ -40 ± 5°C (30 minutes), temperature switch time: 5 minutes (total 50 cycles).	MIL-STD-202G Method 107G Test Condition B-2
Life Test	+70°C ± 5°C (250Hours)	MIL-STD-202G Method 108A Test Condition B

Reliability Experiment For Physical

Test Item	Test Condition	Standard Source
Vibration Test	10-55-10HZ, amplitude: 1.5mm, direction: X, Y, Z axes, each axis 2 hours (total 6 hours).	MIL-STD-202G Method 201A
Solder Heat Resistance Test	IR/convection reflow: Peak Temp 250 ± 5°C for 5Sec in air, Through 2 Cycle. Temperature Ramp: +1~4°C/sec; Above 183°C, must keep 90 s - 120 s	MIL-STD-202G Method 210F Test Condition (Reflow)
Solder Ability Test	Soak in 245 °C solder pot of 3Sec, PAD must have 95% above coverage.	J-STD-003B

Tape & Reel Packaging Dimensions:

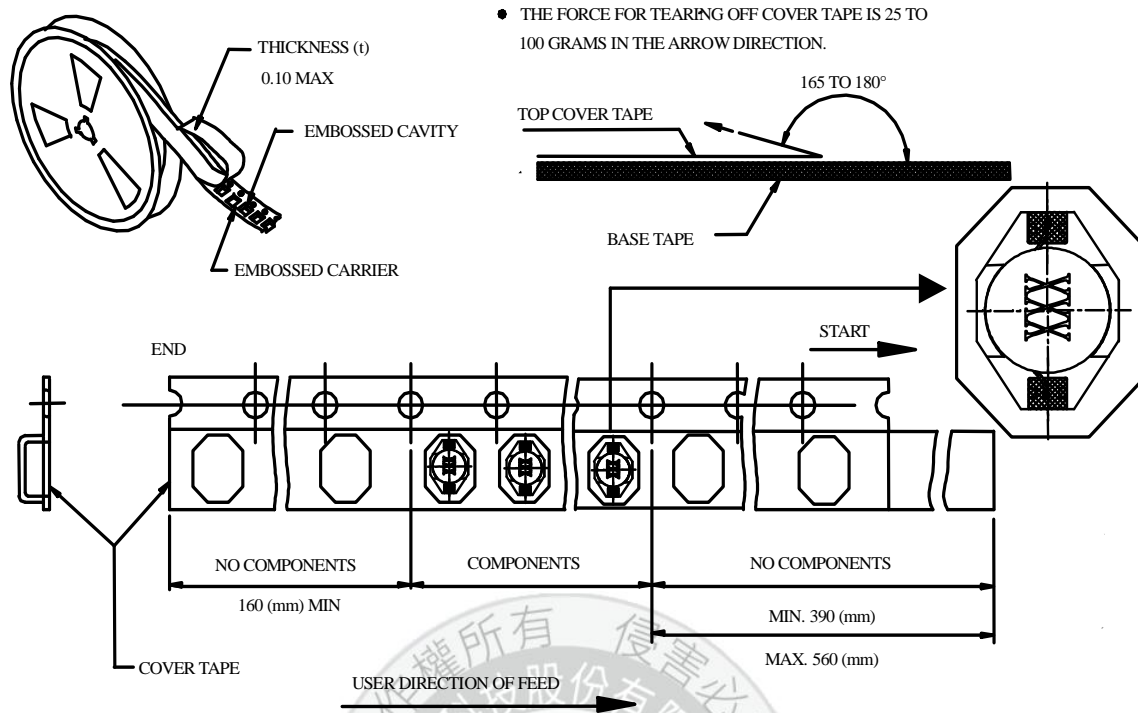

■ CARRIER TAPE REELS (mm)

MATERIAL: PLASTIC

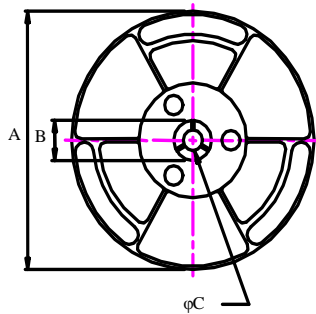

■ DIMENSIONS OF CARRIER TAPE (mm)

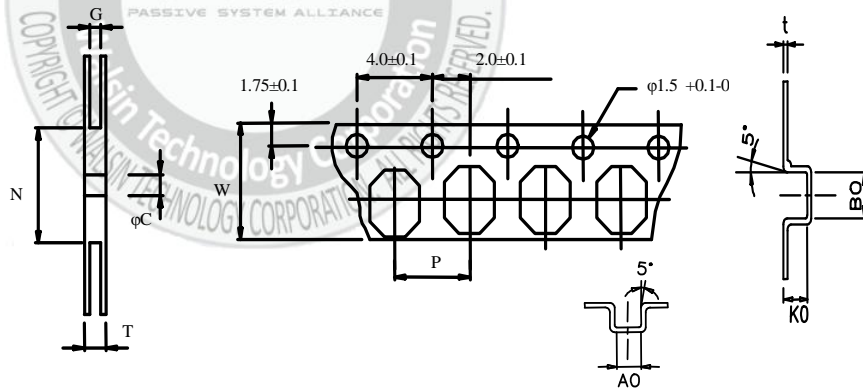

UNIT : mm

	A	B	C	G	N	P	T	W	t	A0	B0	K0
DIM.	340	20.2	13.0	24.5	100	16.0	30.4	24.0	0.35	9.7	13.4	5.5
TOL.	MAX	MIN	±0.5	+3/-0	REF	±0.1	MAX	±0.3	±0.05	±0.1	±0.1	±0.1

Quantity per reel : 0.75K pcs