

NOTICE: ALL PARTS MUST MEET TO RoHS REQUIREMENTS

REV.	DESCRIPTION	DRAWN	APPROVED	DATE
X1	NEW DRAWING	D.Chol	A.Chul	2021.02.23

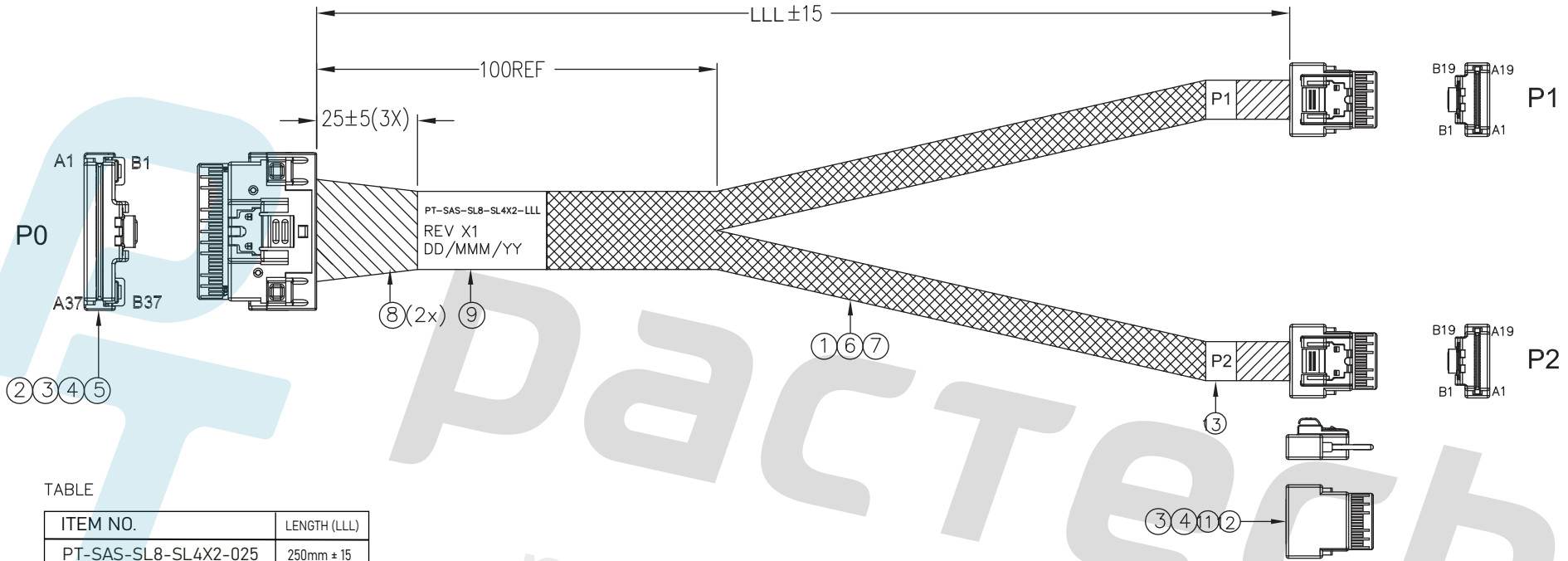

TABLE

ITEM NO.	LENGTH (LLL)
PT-SAS-SL8-SL4X2-025	250mm ± 15
PT-SAS-SL8-SL4X2-050	500mm ± 15
PT-SAS-SL8-SL4X2-750	750mm ± 15
PT-SAS-SL8-SL4X2-1000	1000mm ± 15

③	LABEL	LxW=57*14mm ,PP,WHITE,WITH BLACK TEXT,R2	2	PCS
②	4i PCB	PCB FOR SLIMLINE SAS 4i STR, AU30u",85 Ohm	2	PCS
①	HOUSING	HOUSING FOR SFF-8654 4i STR, BLACK	2	PCS
⑩	FLAT CABLE	FLAT CABLE,32AWGx2C,VW-1,PH=0.6mm,R2	AR	M
⑨	LABEL	LxW=26*57mm ,PP,WHITE,WITH BLACK TEXT,R2	1	PCS
⑧	AC TAPE	BLACK AC TAPE T=0.12mm,R2	AR	M
⑦	PET	OD=9.5mm,PET,BLACK,VW-1,R2	AR	M
⑥	FLAT CABLE	FLAT CABLE,32AWGx5C,BLACK,VW-1,PH=0.6mm,R2	AR	M
⑤	PA	PA6+20%GF,BLACK,UL94V-0,R2	AR	KG
④	PE	PE-LOW DENSITY,NATURAL,R2	AR	KG
③	LATCH	LATCH,SLIMLINE MINI SAS LATCH SUS301 3/4H, T=0.25mm,R2	3	PCS
②	PCB	Slimline SAS 74PIN STR PCB,85ohm,TU862,Au30u",Ni 100U"Min,R2	1	PCS
①	SAS CABLE	SAS3.0 CABLE,UL20744,(30AWGx2C+2EAM)X1P,BLUE,85u,VW-1,12G,R2	AR	M
NO	NAMF	MATRIAL DFSCRIPTION	O'TY	UNIT

NOTE:

1. ALL CABLE 100% OPEN, SHORT, MISS WIRE & TRANSIENT FAULT TEST;
 2. THE DIMENSIONS MARKED ▼ SHALL BE CHECKED ;
 3. CONDUCTOR RESISTANCE : 2.0 ohm Max.;
 4. INSULATION RESISTANCE : 10 Mohm Min/300VDC@10ms;
 5. HIGH FREQUENCY CHARACTERISTIC PLEASE FOLLOW PCIe Gen 4 INDUSTRIAL STANDARD.
- Connector Impedance: 85±15 ohm , Cable Impedance: 85±5 ohm

1. .* ±0.1 2. .** ±0.1 3. *** ±0.05 4 FRACT.±1/32" 5. ANGULAR ±1/2'	Customer P/N: N/A	
	Customer REV.: N/A	
	PART NO.	TITLE X8 SFF-8654 to 2X4 SFF-8654
	SEE TABLE	DRAWING NO. PT-SAS-SL8-SL4X2-LLL
	APPROVED A.Chul	UNIT SCALE SHEET REV. MM NONE 1/2 X1
CHECKED A.Chul	DATE 2021-02-23	
DRAWN D.Chol		

NOTICE:
 RoHS ALL PARTS MUST MEET TO RoHS REQUIREMENTS

REV.	DESCRIPTION	DRAWN	APPROVED	DATE
X1	NEW DRAWING	D.Choi	A.Chui	2021.02.23

WIRE CONNECTION TABLE

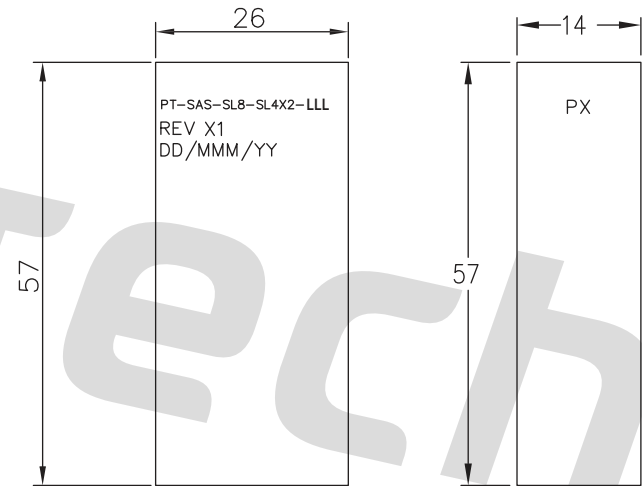
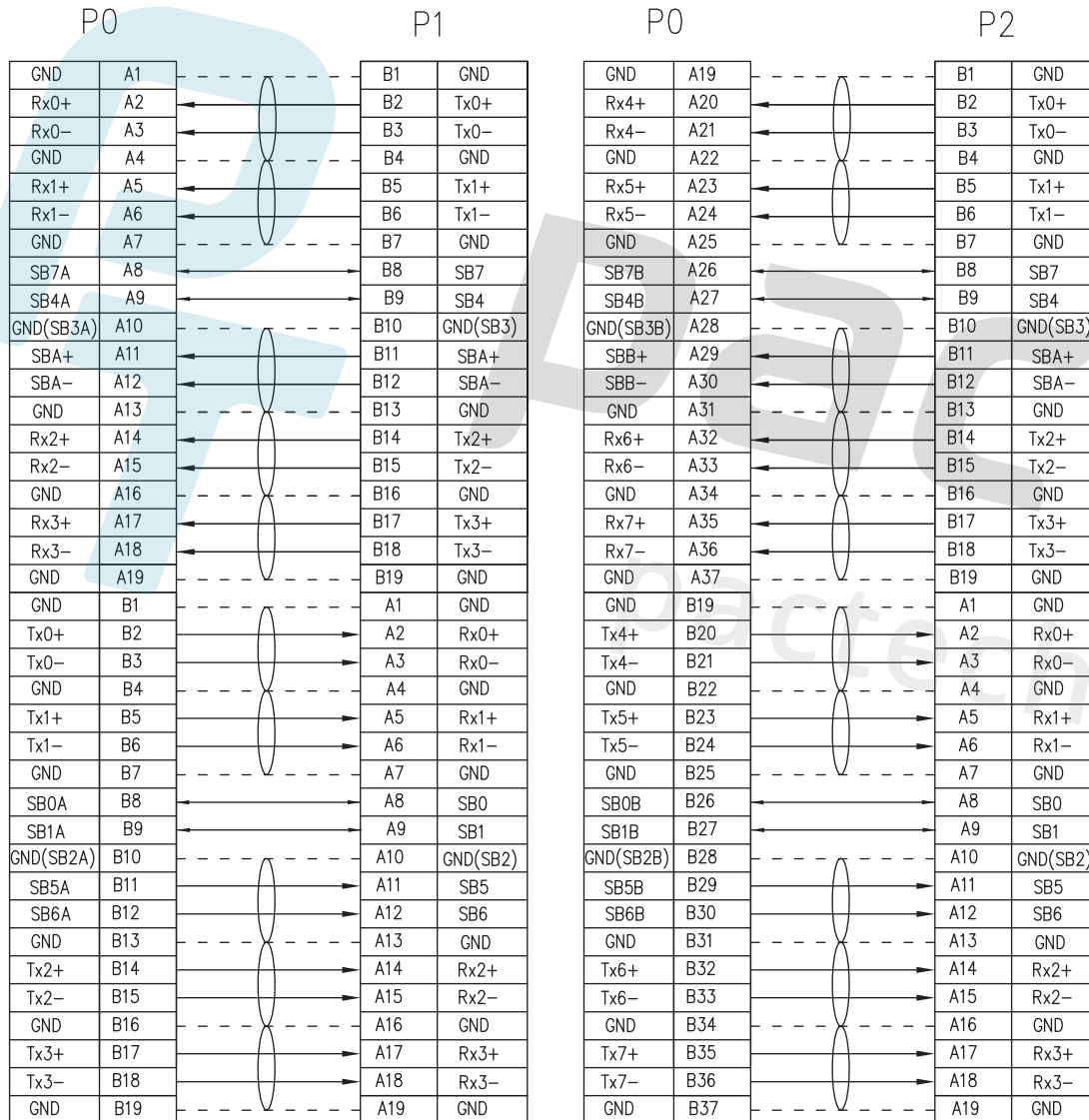

PRINT DETAIL:
 1.FONTS:ARIAL.
 2.HEIGHT: 2.0mm

1. .* ±0.1 2. .** ±0.1 3. .*** ±0.05 4. FRACT.±1/32" 5. ANGULAR ±1/2"	Customer P/N: N/A		TITLE X8 SFF-8654 to 2X4 SFF-8654
	Customer REV.: N/A		
	PART NO. SEE TABLE		
	APPROVED A.Chui	DRAWING NO. PT-SAS-SL8-SL4X2-LLL	
	CHECKED A.Chui		
DRAWN D.Choi	UNIT SCALE SHEET REV.	MM NONE 2/2 X1	
DATE 2021-02-23			