

## Features

- **Single channel pin compatible population option for Le9662 or Le9672 two channel, 100 V maximum battery designs**
  - Lower overall costs by producing a single design with a 1 or 2 channel assembly option
- **Highly-integrated, low power, cost-effective voice solution, enabling reduced BOM costs**
- **Single port 4-wire interface control (ZSI)**
  - Compatible with numerous VoIP processors and SoC solutions
  - Less expensive isolation than multi-port control
  - Simplifies board routing
- **VoicePath SDK and VP-API-II Software available to implement FXS functions**
- **VeriVoice Professional Test Suite Software**
  - Comprehensive subscriber loop testing, including *Telcordia GR-909-CORE / TIA-1063* diagnostic testing
  - Industry leading advanced test software
- **VeriVoice Manufacturing Test Package (VVMT)**
  - Facilitates factory testing and calibration of assembled boards
- **Low cost, energy efficient switching regulator architectures, satisfying V5.0 European Code of Conduct on Energy Consumption of Broadband Equipment**
  - Up to 65 V<sub>RMS</sub> open circuit ringing with up to 5 REN load
- **Low cost, 2-Layer PCB Reference Designs**
- **Complete Wideband BORSCHT functionality**
- **Worldwide Programmability**
- **Narrowband or Wideband operation**

## Applications

- **VDSL2 Residential Gateways and Integrated Access Devices (IADs)**
- **Docsis 3.0 Cable Embedded Multimedia Terminal Adapters (eMTAs)**
- **PON Single Family Units (SFU)**
- **GPON and EPON Fiber-to-the-premise (FTTX) solutions**

Document ID# 149169

Version 1

March 2014

### Ordering Information

Device OPN	Device Type	Package	Packing
Le9661WQCT	SLIC, Tracker	56-pin QFN	Tape&Reel
Le9661WQC	SLIC, Tracker	56-pin QFN	Tray

*These Green packages meet RoHS 2 Directive 2011/65/EU of the European Council to minimize the environmental impact of electrical equipment.*

### Description

The miSLIC™ Line Circuits together with a ZSI enabled VoIP processor or SoC, provides an economical turn-key solution for derived voice applications. The miSLIC devices are controlled by a VoIP processor or SoC through a simple, single serial interface.

The Le9661 miSLIC 1 FXS Tracking device is a drop-in pin compatible device to the miSLIC 2 FXS Le9662 FBABS or Le9672 Tracker devices. The Le9661 uses energy efficient power supply topologies for reduced BOM cost. The Le9661 can be configured to operate a flyback full tracking supply or an inverting buck-boost fixed tracking supply. Ringing and system power management are supported to limit the peak power requirements of the telephone line FXS port. The Le9661 features wideband clarity and complete BORSCHT functionality.

Manufacturing self test and subscriber line diagnostics are available features. All AC, DC, and power parameters are programmable making the Le9661 device suitable for any short loop application requiring SLIC functionality.

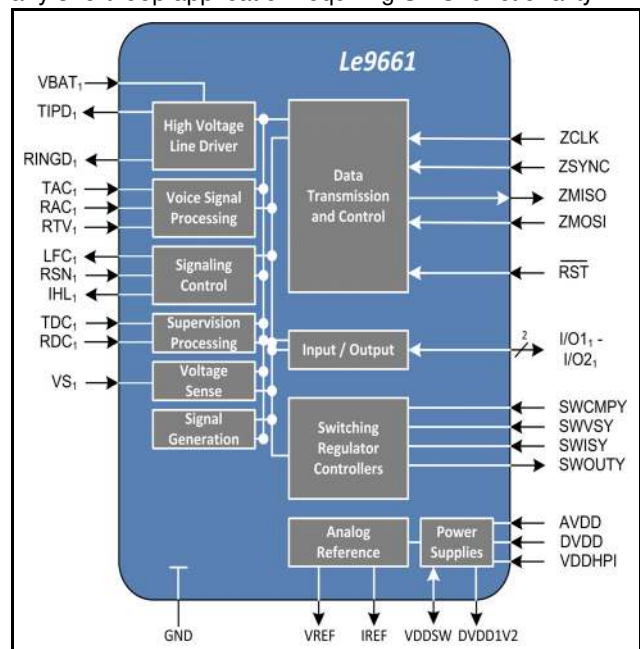

Figure 1 - Le9661 Block Diagram

### Selected Electrical Specifications

Description	Symbol	Test Conditions	Min	Typ	Max	Unit
Ambient Temperature, under Bias	$T_A$		-40		+85	°C
Digital and Analog Supply Voltages	DVDD, AVDD		3.135	3.3	3.465	$V_{DC}$
Operating Limits: $V_{BAT1}$ (in active state)			-105 $V_{DC}$ to -12 $V_{DC}$			$V_{DC}$
Line Current: Buck-boost operation Flyback operation	$I_{LA}$		18 18	25 25	30 45	mA
Ringing Voltage	$V_{RING}$	5REN		50	65	$V_{RMS}$
Two-Wire Return Loss	$R_L$	200 to 3400 Hz		30		dB
Longitudinal Balance		1 kHz		58		dB
Device Power Dissipation, Continuous	$P_{D(max)}$	$T_A = 85^\circ C$		2		W
Junction to Ambient Thermal Resistance	$\theta_{JA}$			27		°C/W

Device Power Consumption	Symbol	Test Conditions	Typ	Unit
Shutdown	$P_D$	Switcher off	8	mW
Disconnect			37	
Low Power Idle Mode		On-Hook	52	
Idle		On-Hook	98	
Active		Off-Hook, 300 $\Omega$ , $I_{LA} = 25$ mA	324	
Ringing		50 $V_{RMS}$ , 1REN	462	

### Device Pinout

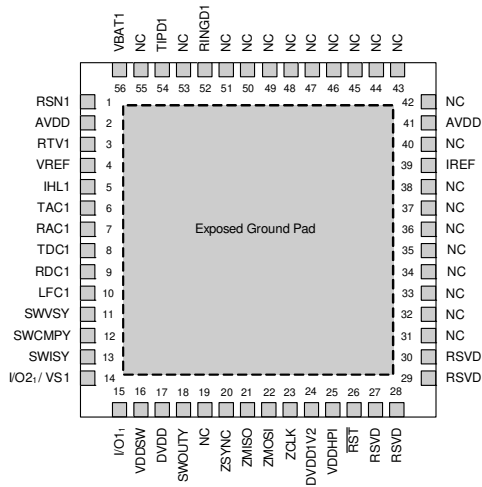

### Package Drawings

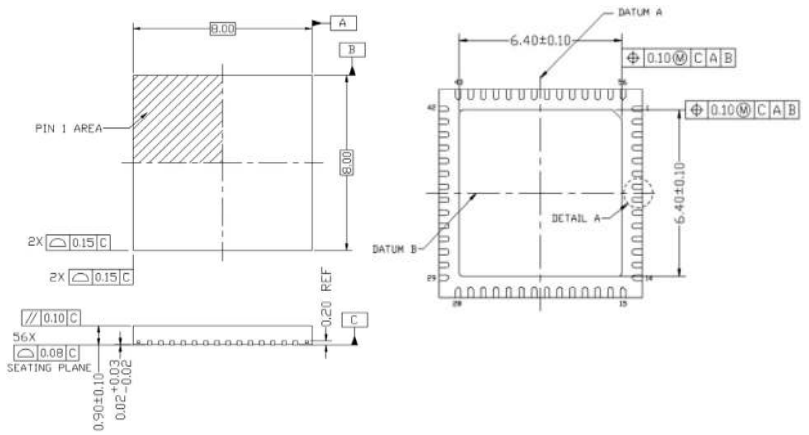

### Related Collateral

- *Le9661 Tracking Battery miSLIC™ Line Circuit Preliminary Data Sheet*, Document ID# 148233
- *Le9662 Shared Battery Dual miSLIC™ Line Circuit Preliminary Data Sheet*, Document ID# 146852
- *Le9672 Tracking Battery Dual miSLIC™ Line Circuit Preliminary Data Sheet*, Document ID# 146853