

REVISIONS					
P	LTR	DESCRIPTION	DATE	DWN	APVD
	A	DRAWN	01NOV05	JR	TM
	A1	REVISED PER ECO-17-008114	05JUN2018	RS	DR

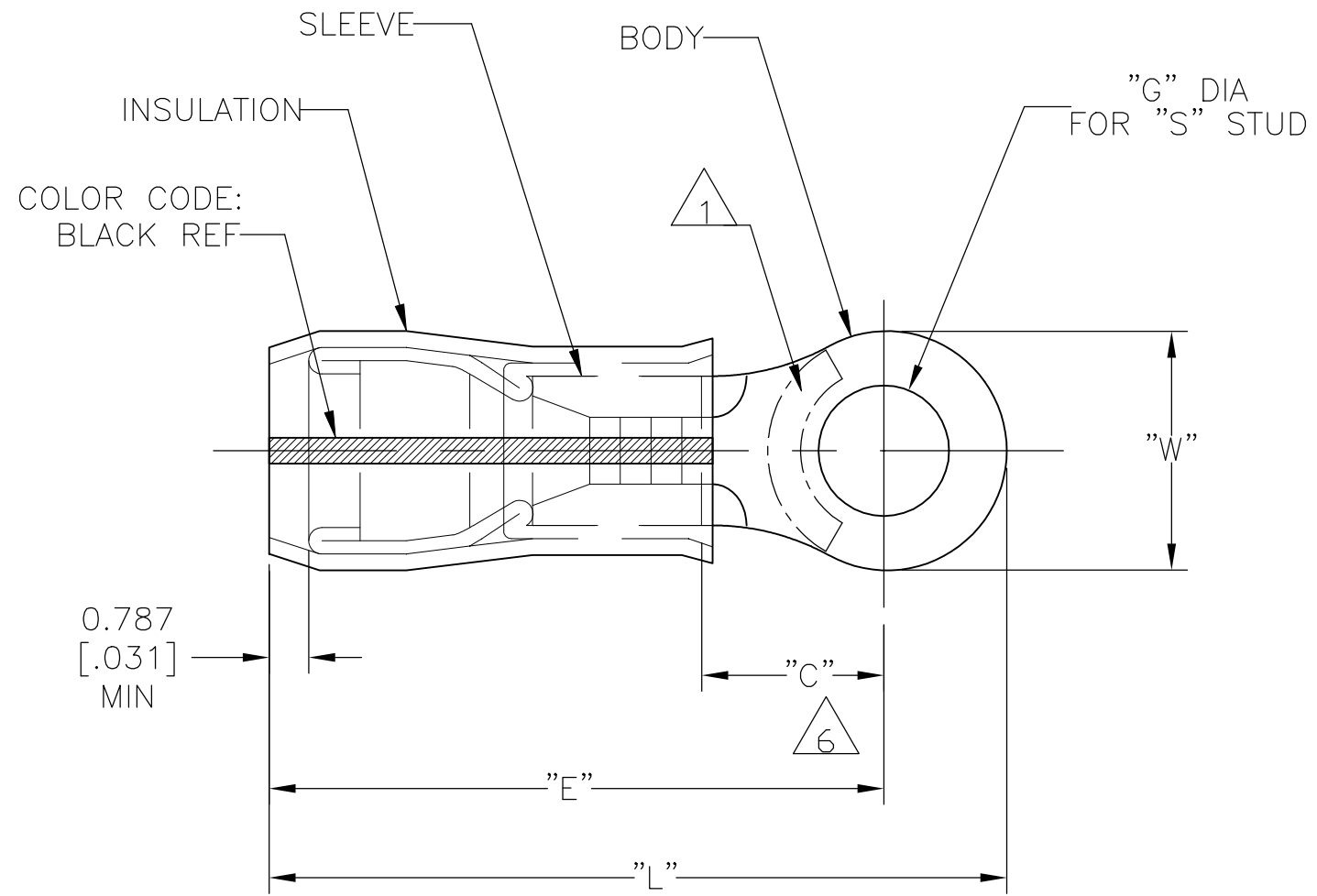

- 1 STAMP AMP 16-14HD, APPROX AS SHOWN
- 2 WIRE INSULATION DIA: 3.810-5.842[.150-.230]
- 3 BODY MATERIAL THK: 1.219±0.051[.048±.002]
- 4 BODY & SLEEVE: TIN PLATE PER ASTM B545, INSULATION: COLOR-NATURAL
- 5 BODY & SLEEVE: CU PER ASTM B152 INSULATION: PVF2
- 6 APPLIES FROM EDGE OF METAL WIRE BARREL TO CENTER OF STUD HOLE.

8.712[.343]	7.137[.281] MIN	22.276[.877] MAX	4.343±0.076[.171±.003]	M4[#8]	26.695[1.051] MAX	500	LOOSE PIECE	696430-5
"W"	"C"	"E"	"G" DIA	"S"	"L"	QTY	PACKAGE TYPE	PART NO

AMP INCORPORATED CUSTOMER SERVICE SYSTEMS		MAX RECOMMENDED OPERATING TEMPERATURE: 150°C[302°F] MAX	THIS DRAWING IS A CONTROLLED DOCUMENT.		DWN JR RUTH 01NOV05	TE Connectivity Ltd.					
FOR ADDITIONAL PRODUCT INFORMATION OR COPIES OF DRAWINGS AND TECHNICAL DOCUMENTS	PRODUCT INFORMATION CENTER 1-800-522-6752	VOLTAGE RATING: -	DIMENSIONS: mm [INCHES]	TOLERANCES UNLESS OTHERWISE SPECIFIED:	CHK T MICHIELUTTI 01NOV05					NAME TERMINAL, RING TONGUE, PVF2, P.I.D.G. WIRE SIZE: 16-14 AWG HD	
FOR APPLICATION TOOLING INFORMATION	TOOLING ASSISTANCE CENTER 1-800-722-1111	CIRCULAR MIL AREA: 1.04-2.62mm²[2,050-5,180] STRANDED		0 PLC ± - 1 PLC ± - 2 PLC ± - 3 PLC ± 0.127[.005] 4 PLC ± - ANGLES ± -	APVD T MICHIELUTTI 01NOV05	PRODUCT SPEC -	APPLICATION SPEC 114-2157	SIZE A3	CAGE CODE 00779	DRAWING NO G-696430	RESTRICTED TO -
FOR ORDER ENTRY	1-800-526-5142	THIS DRAWING IS A CONTROLLED DOCUMENT FOR AMP INCORPORATED. IT IS SUBJECT TO CHANGE AND THE CONTROLLING ENGINEERING ORGANIZATION SHOULD BE CONTACTED FOR THE LATEST REVISION.		MATERIAL - 5	FINISH - 4	WEIGHT -	CUSTOMER DRAWING		SCALE 4:1	SHEET 1 OF 1	REV A1