

DO NOT SCALE FROM THIS PRINT

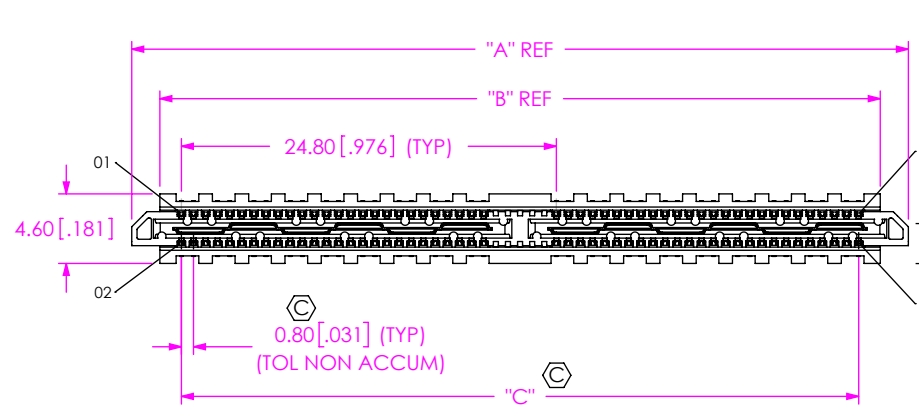

No OF POSITIONS
 -026, -052, *-078
 (-018, -036, *-054 FOR -DP ONLY)

LEAD STYLE
 -02.0 = 2mm (SEE FIG. 1)
 -05.0 = 5mm (SEE FIG. 3, SHT 2)
 -07.0 = 7mm

PLATING SPECIFICATION
 -L: 10µ" LIGHT SELECTIVE GOLD / MATTE TIN
 (USE T-1M53-XX.X-L & T-1G38-XX.X-L)
 -S: 30µ" SELECTIVE GOLD / MATTE TIN
 (USE T-1M53-XX.X-S & T-1G38-XX.X-S)
 * = NOT AVAILABLE IN -02.0 LEAD STYLE

PACKAGING
 BLANK: TRAYS (SEE NOTE 10)
 -TR: TAPE & REEL (SEE NOTE 11 & 12)
 -FR: FULL REEL QTY TAPE & REEL (SEE NOTE 11 & 12)

PICK & PLACE OPTION
 -K: POLYIMIDE FILM PAD

OPTIONS
 -GP: GUIDE POST (SHEET 3, FIG 4)(SEE NOTE 8)

OPTIONS
 -A: ALIGNMENT PIN

OPTION (IF NOT APPLICABLE, LEAVE BLANK)
 -DP: DIFFERENTIAL PAIRS (SHEET 4, FIG 5)

ROW SPECIFICATION
 -D: DOUBLE

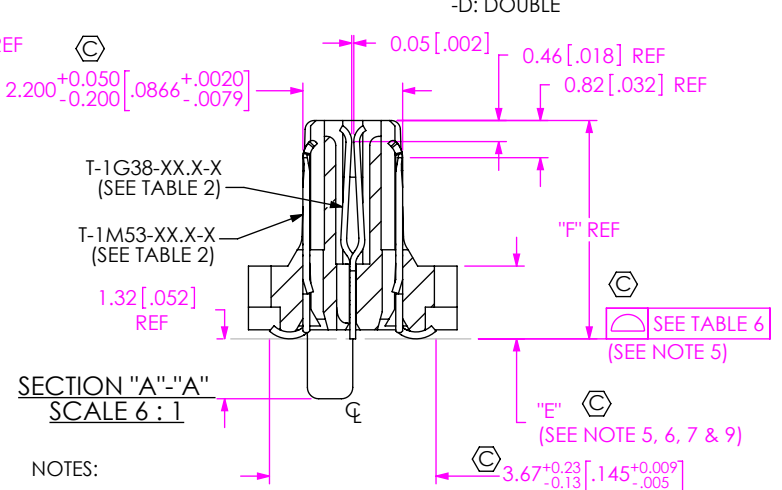
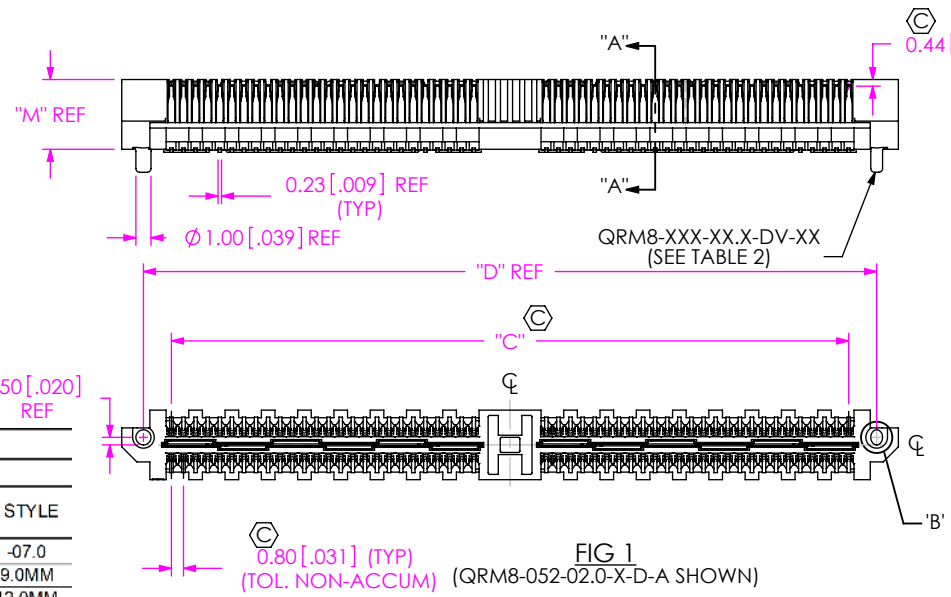

TABLE 1 REF
 STACK HEIGHT

QRM8 LEAD STYLE	QRF8 LEAD STYLE	
	-05.0	-07.0
-02.0	7.0MM	9.0MM
-05.0	10.0MM	12.0MM
-07.0	12.0MM	14.0MM

TABLE 2

LEAD STYLE	QRM8-XXX-XX.X-DV-XX	T-1M53-XX.X-X	T-1G38-XX.X-X	"E"	"F"	"M"
-02.0	QRM8-XXX-02.0-DV-XX	T-1M53-02.0-X	T-1G38-02.0-X	1.61 [0.063]	4.81 [0.189]	4.62 [0.182]
-05.0	QRM8-XXX-05.0-DV-XX	T-1M53-05.0-X	T-1G38-05.0-X	4.61 [0.181]	7.81 [0.307]	7.62 [0.300]
-07.0	QRM8-XXX-07.0-DV-XX	T-1M53-07.0-X	T-1G38-07.0-X	6.61 [0.260]	9.78 [0.385]	9.62 [0.379]

TABLE 3

No OF POSITIONS	"A"	"B"	"C"	"D"
-018, -026	26.57 [1.046]	22.85 [0.900]	20.00 [0.787]	23.70 [0.933]
-036, -052	51.37 [2.022]	47.65 [1.876]	44.80 [1.764]	48.50 [1.909]
*-054, *-078	76.17 [2.999]	72.45 [2.852]	69.60 [2.740]	73.30 [2.886]

* = NOT AVAILABLE IN 02.0 LEAD STYLE

TABLE 6

No of POSITIONS	
-018, -026	0.10 [0.004]
-036, -052, -054, -078	0.15 [0.006]

- NOTES:
- ⊗ REPRESENTS A CRITICAL DIMENSION.
 - MAXIMUM BURR ALLOWANCE: 0.038 [0.0015]
 - MINIMUM PUSHOUT FORCE: SIGNAL: 1.60 N [4 LB.]; GROUND PLANE: 4.44 [1LB]
 - NOTE DELETED
 - DIMENSION APPLIES TO CONTACTS & GROUND PLANE.
 - GROUND PLANE PRESS HEIGHT MUST BE 0.08 [0.003] LESS THAN THE MAX HEIGHT OR 0.03 [0.001] GREATER THAN THE MINIMUM HEIGHT OF THE TERMINAL.
 - MAXIMUM VARIANCE OF 0.05 [0.002].
 - PARTS WITH THE -GP OPTION MUST MATE TO -GP OPTIONED QRF8 PARTS AND PARTS WITH NO -GP OPTION MUST MATE TO NON -GP OPTIONED QRF8 PARTS.
 - NOTE DELETED.
 - TRAYS ARE STANDARD PACKAGING
 - ORDERS WILL BE PACKAGED ACCORDING TO THE SAMTEC PACKAGING EFFICIENCY STANDARDS (SPES) FOUND ON WWW.SAMTEC.COM
 - ATTACH LABEL TO EACH REEL

UNLESS OTHERWISE SPECIFIED, DIMENSIONS ARE IN MILLIMETERS [INCHES].
 TOLERANCES ARE:
 DECIMALS ANGLES
 X.X: ±0.3 [0.1] 2°
 X.XX: ±0.13 [0.005]
 X.XXX: ±0.050 [0.0020]

PROPRIETARY NOTE
 THIS DOCUMENT CONTAINS CONFIDENTIAL AND PROPRIETARY INFORMATION AND ALL DESIGN, MANUFACTURING, REPRODUCTION, USE, PATENT RIGHTS AND SALES RIGHTS ARE EXPRESSLY RESERVED BY SAMTEC, INC. THIS DOCUMENT SHALL NOT BE DISCLOSED, IN WHOLE OR PART, TO ANY UNAUTHORIZED PERSON OR ENTITY NOR REPRODUCED, TRANSFERRED OR INCORPORATED IN ANY OTHER PROJECT IN ANY MANNER WITHOUT THE EXPRESS WRITTEN CONSENT OF SAMTEC, INC.



520 PARK EAST BLVD, NEW ALBANY, IN 47150
 PHONE: 812-944-6733 FAX: 812-948-5047
 e-Mail info@SAMTEC.com code 55322

MATERIAL: INSULATOR: LCP, COLOR: BLACK
 TERMINAL & GROUND PLANE: PHOS. BRZ.

DESCRIPTION: .8MM Q-RATE TERMINAL ASSEMBLY

DWG. NO. QRM8-XXX-XX.X-X-D-XX-A-XX-X-XX

BY: CLAY W 8/27/2008 SHEET 1 OF 4

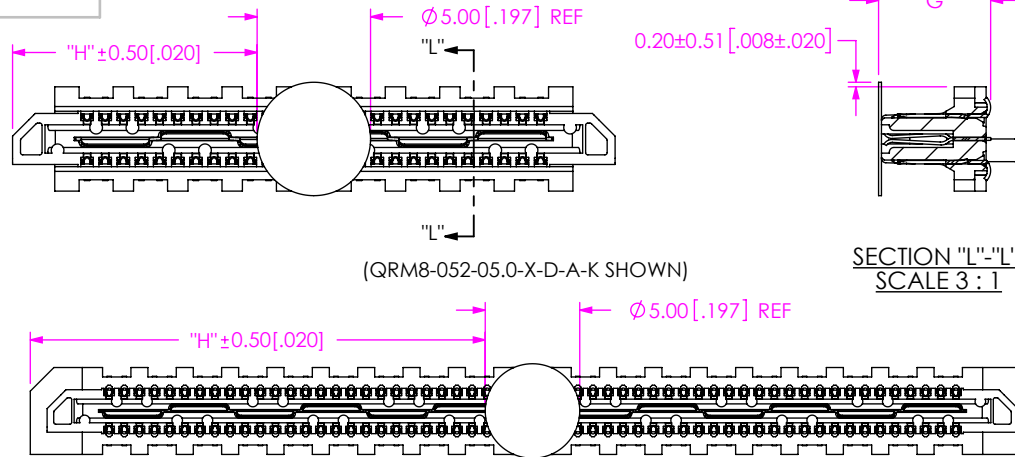

SECTION "L"-L"
SCALE 3:1

LEADSTYLE	POSITION	"H"
-02.0	-018, -026	10.78 [.424]
	-036, -052	23.18 [.913]
-02.0 W/-GP	-018, -026	11.68 [.460]
	-036, -052	24.08 [.948]
-05.0 & -07.0	-018, -026	11.68 [.460]
	-036, -052	24.08 [.948]
	-054, -078	36.48 [1.436]

LEAD STYLE	"G"
-02.0	4.94 [0.194]
-05.0	7.94 [0.313]
-07.0	9.94 [0.391]

FIG 2
-K OPTION
(USE K-DOT-.197-.344-.005)
(QRM8-026-02.0-X-D-A-K SHOWN)

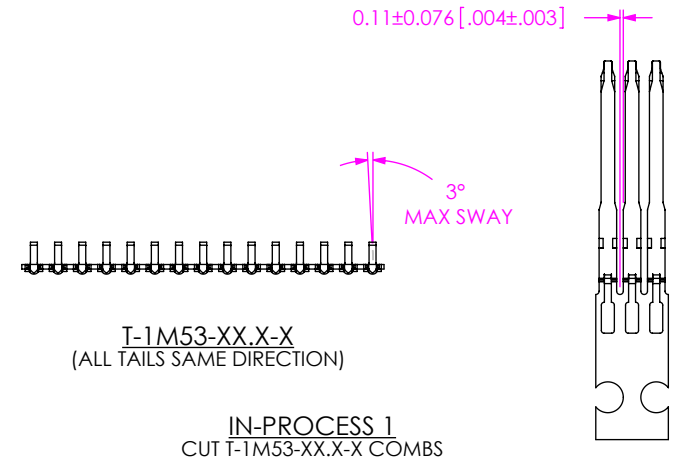

T-1M53-XX.X-X
(ALL TAILS SAME DIRECTION)

IN-PROCESS 1
CUT T-1M53-XX.X-X COMBS

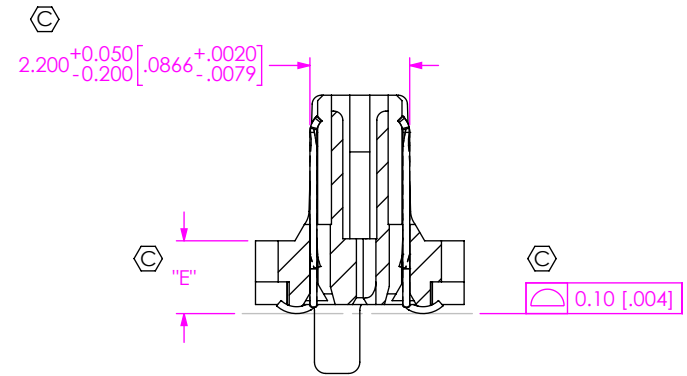

IN-PROCESS 2
FILL T-1M53-XX.X-X TERMINALS

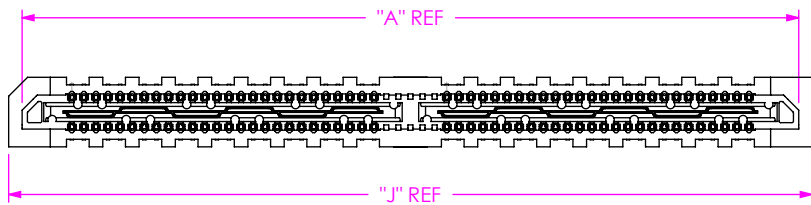

POSITION	"J"
-018, -026	28.35 [1.116]
-036, -052	53.15 [2.093]
*-054, *-078	77.95 [3.069]

* = NOT AVAILABLE IN -02.0 LEAD STYLE

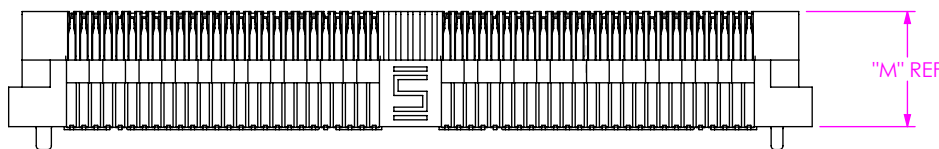

FIG 3
(QRM8-052-05.0-X-D-A SHOWN)
(SAME AS FIG 1 EXCEPT AS SHOWN)

PROPRIETARY NOTE
THIS DOCUMENT CONTAINS CONFIDENTIAL AND PROPRIETARY INFORMATION AND ALL DESIGN, MANUFACTURING, REPRODUCTION, USE, PATENT RIGHTS AND SALES RIGHTS ARE EXPRESSLY RESERVED BY SAMTEC, INC. THIS DOCUMENT SHALL NOT BE DISCLOSED, IN WHOLE OR PART, TO ANY UNAUTHORIZED PERSON OR ENTITY NOR REPRODUCED, TRANSFERRED OR INCORPORATED IN ANY OTHER PROJECT IN ANY MANNER WITHOUT THE EXPRESS WRITTEN CONSENT OF SAMTEC, INC.

DO NOT SCALE DRAWING

SHEET SCALE: 2:1



520 PARK EAST BLVD, NEW ALBANY, IN 47150
PHONE: 812-944-6733 FAX: 812-948-5047
e-Mail info@SAMTEC.com code 55322

DESCRIPTION:
.8MM Q-RATE TERMINAL ASSEMBLY

DWG. NO.
QRM8-XXX-XX.X-X-D-XX-A-XX-X-XX

BY: CLAY W 8/27/2008 SHEET 2 OF 4

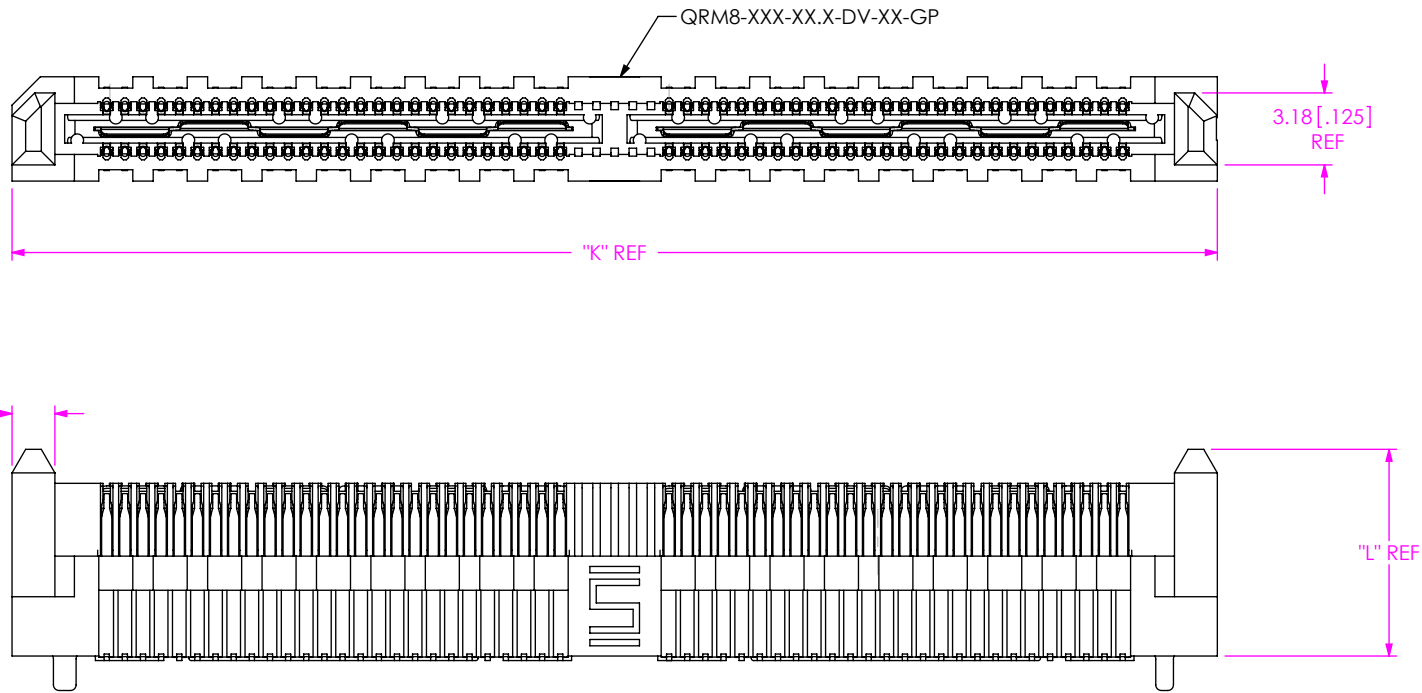

FIG 4
(QRM8-052-05.0-X-D-A-GP SHOWN)
(SAME AS FIG 2 EXCEPT AS SHOWN)

POSITION	"K"
-018, -026	28.35 [1.116]
-036, -052	53.15 [2.093]
*-054, *-078	77.95 [3.069]

* = NOT AVAILABLE IN -02.0 LEADSTYLE

LEAD STYLE	"L"
-02.0	6.12 [0.241]
-05.0	9.12 [0.359]
-07.0	11.12 [0.438]

PROPRIETARY NOTE
 THIS DOCUMENT CONTAINS CONFIDENTIAL AND PROPRIETARY INFORMATION AND ALL DESIGN, MANUFACTURING, REPRODUCTION, USE, PATENT RIGHTS AND SALES RIGHTS ARE EXPRESSLY RESERVED BY SAMTEC, INC. THIS DOCUMENT SHALL NOT BE DISCLOSED, IN WHOLE OR PART, TO ANY UNAUTHORIZED PERSON OR ENTITY NOR REPRODUCED, TRANSFERRED OR INCORPORATED IN ANY OTHER PROJECT IN ANY MANNER WITHOUT THE EXPRESS WRITTEN CONSENT OF SAMTEC, INC.

DO NOT SCALE DRAWING

SHEET SCALE: 3:1



520 PARK EAST BLVD, NEW ALBANY, IN 47150
 PHONE: 812-944-6733 FAX: 812-948-5047
 e-Mail info@SAMTEC.com code 55322

DESCRIPTION: .8MM Q-RATE TERMINAL ASSEMBLY

DWG. NO. QRM8-XXX-XX.X-X-D-XX-A-XX-X-XX

BY: CLAY W 8/27/2008 SHEET 3 OF 4

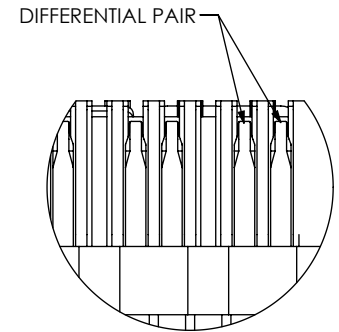
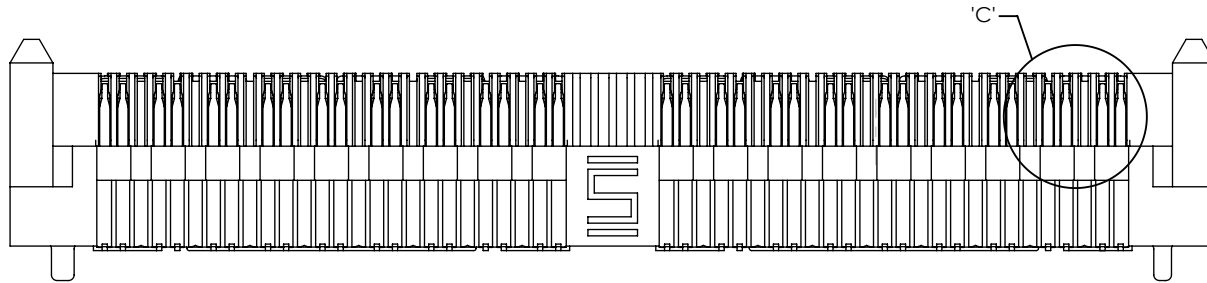
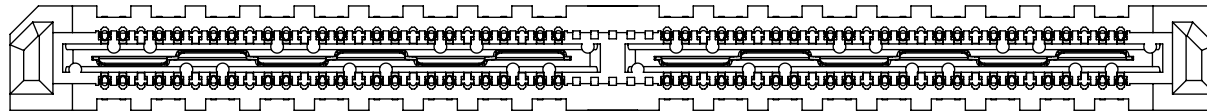

DETAIL 'C'
SCALE 6 : 1

FIG 5
(QRM8-036-05.0-X-D-DP-A-GP SHOWN)
(SAME AS FIG 4 EXCEPT AS SHOWN)

$\text{C} \ 0.11 \pm 0.076 \ [.004 \pm .003]$
(TYP)

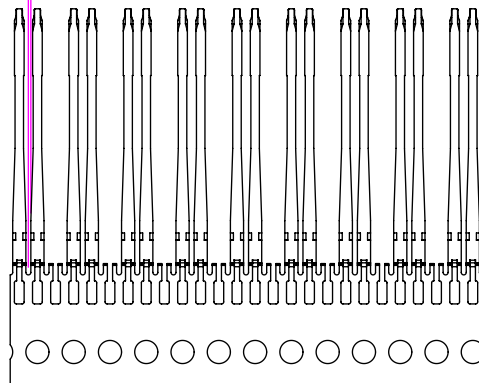

3°
MAX SWAY

IN-PROCESS 3
CUT T-1M53-XX.X-X COMBS
(FOR QRM8-XXX-XX.X-D-DP-A-XX)

PROPRIETARY NOTE
THIS DOCUMENT CONTAINS CONFIDENTIAL AND PROPRIETARY INFORMATION AND ALL DESIGN, MANUFACTURING, REPRODUCTION, USE, PATENT RIGHTS AND SALES RIGHTS ARE EXPRESSLY RESERVED BY SAMTEC, INC. THIS DOCUMENT SHALL NOT BE DISCLOSED, IN WHOLE OR PART, TO ANY UNAUTHORIZED PERSON OR ENTITY NOR REPRODUCED, TRANSFERRED OR INCORPORATED IN ANY OTHER PROJECT IN ANY MANNER WITHOUT THE EXPRESS WRITTEN CONSENT OF SAMTEC, INC.

DO NOT SCALE DRAWING

SHEET SCALE: 3:1



520 PARK EAST BLVD, NEW ALBANY, IN 47150
PHONE: 812-944-6733 FAX: 812-948-5047
e-Mail info@SAMTEC.com code 55322

DESCRIPTION: .8MM Q-RATE TERMINAL ASSEMBLY

DWG. NO. QRM8-XXX-XX.X-X-D-XX-A-XX-X-XX

BY: CLAY W 8/27/2008 SHEET 4 OF 4