

REVISIONS				
P	LTR	DESCRIPTION	DATE	APVD
	AB5	REVISED PER ECR-17-013215	18SEP17	J.Z D.Z

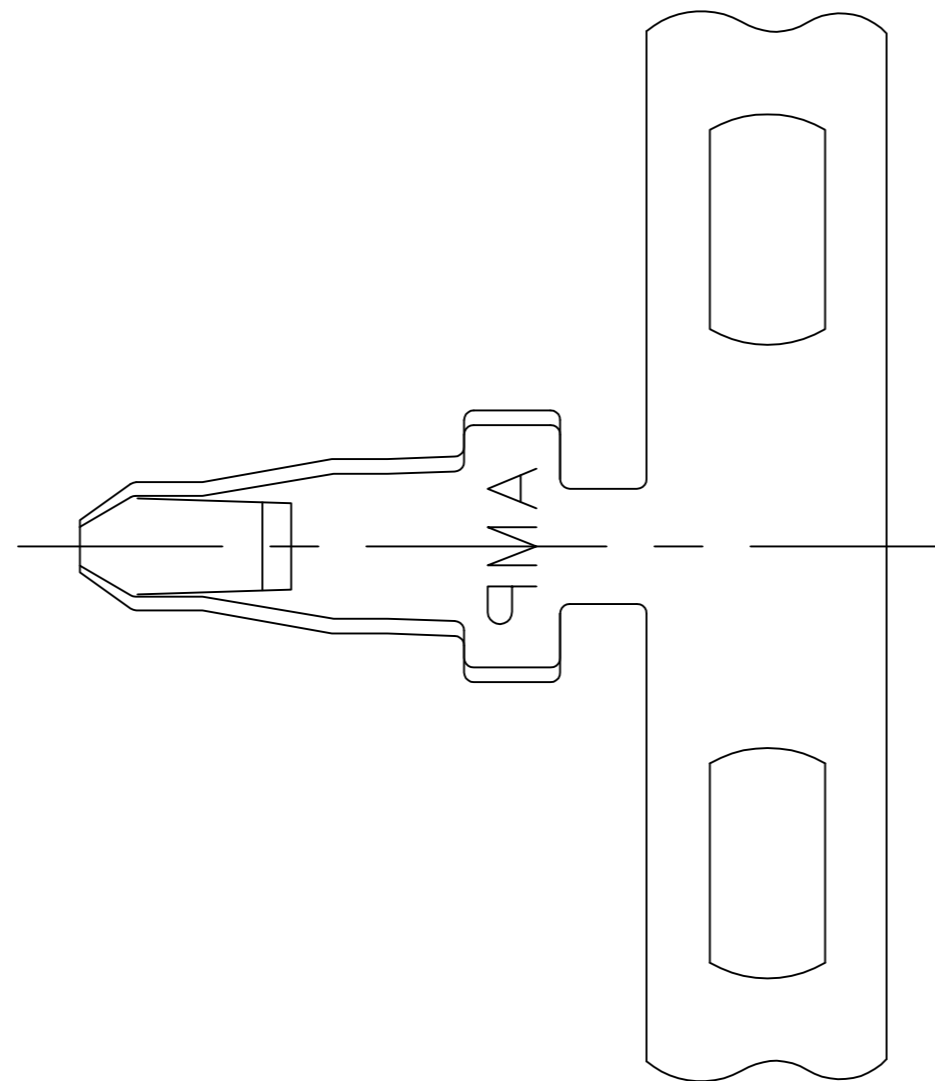

- 1 PARTS COMPLY WITH AMP SOLDERABILITY SPEC 109-11-3.
- 2 PARTS COMPLY WITH AMP SOLDERABILITY SPEC 109-11-5.
- 3 PARTS COMPLY WITH AMP SOLDERABILITY SPEC 109-11-1.
- 4 HOLE DIAMETER TO BE 1.83±0.08 FOR WIRE 0.3-0.6mm² (20-22 AWG) OR 1.96±0.08 FOR WIRE 0.8-0.9mm² (18 AWG).
- 5 CARRIER STRIP TO HAVE 1.52 [.060] DIA PILOT HOLE.
- 6 0.00508 [.000200] MIN BRIGHT TIN-LEAD.
- 7 0.00318 [.000150] MIN MATTE TIN-LEAD OVER
0.00305 [.000120] MIN MATTE COPPER.
- 8 0.00305 [.000120] MIN TIN OVER
0.00102 [.000040] MIN NICKEL.
- 9 WIRE RANGE: 0.3 -0.9 mm² (22 - 18 AWG).
- 10 INSULATION RANGE: 1.52 - 2.79 [.060 - .110] DIA.
- 11 DIMENSIONS IN BRACKETS ARE IN INCHES.
- 12 0.00508 [.000200] MIN BRIGHT TIN.

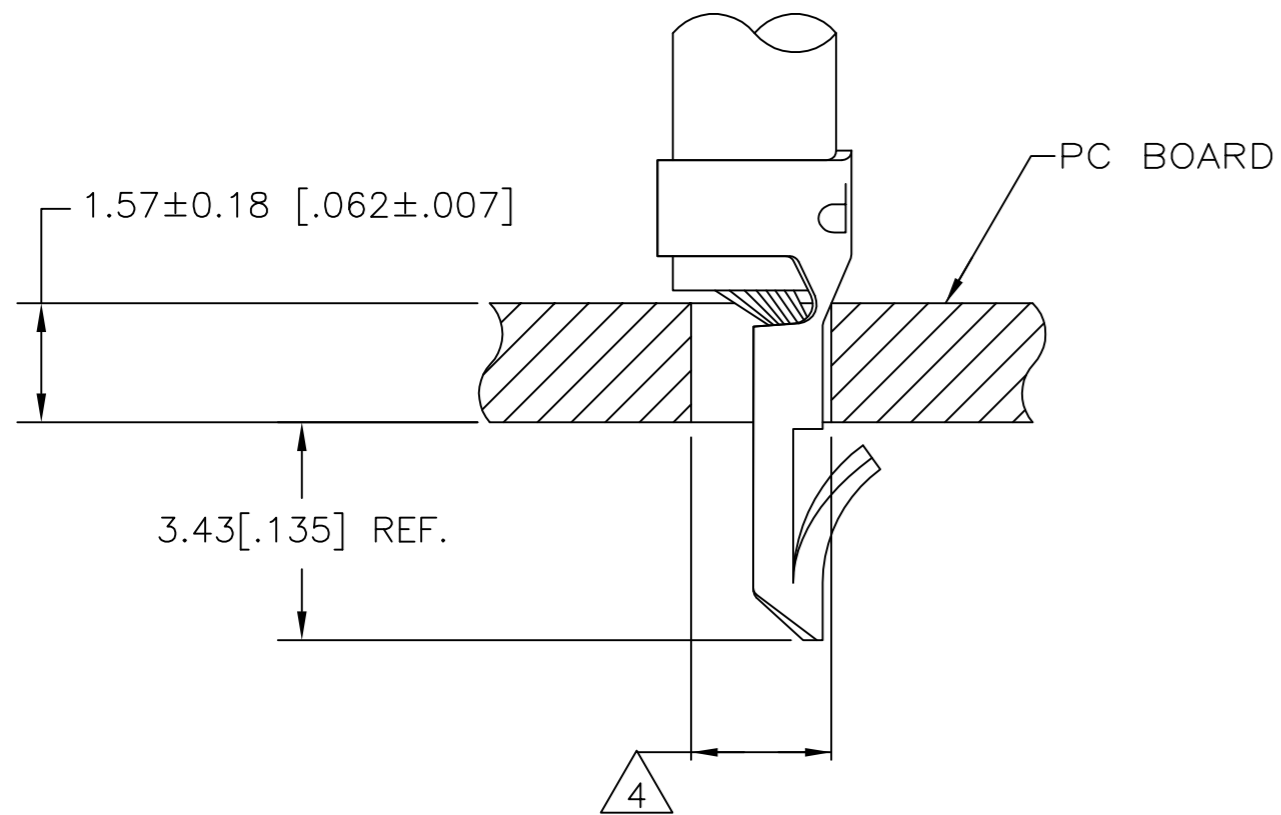
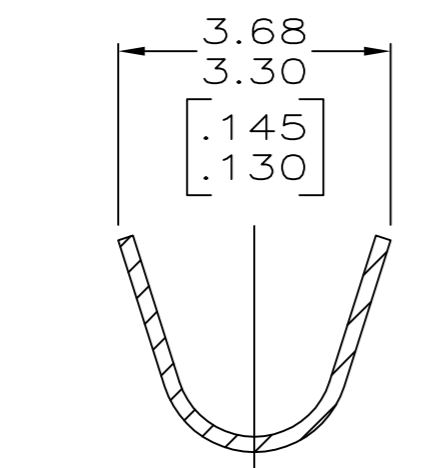
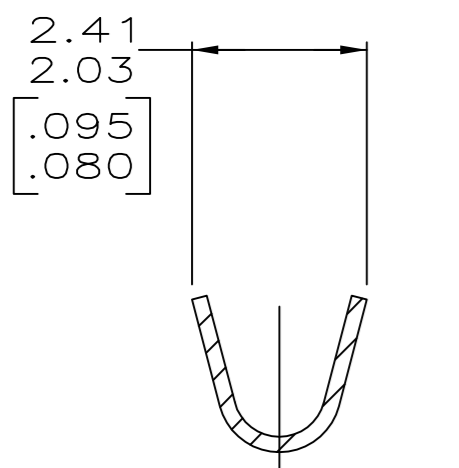
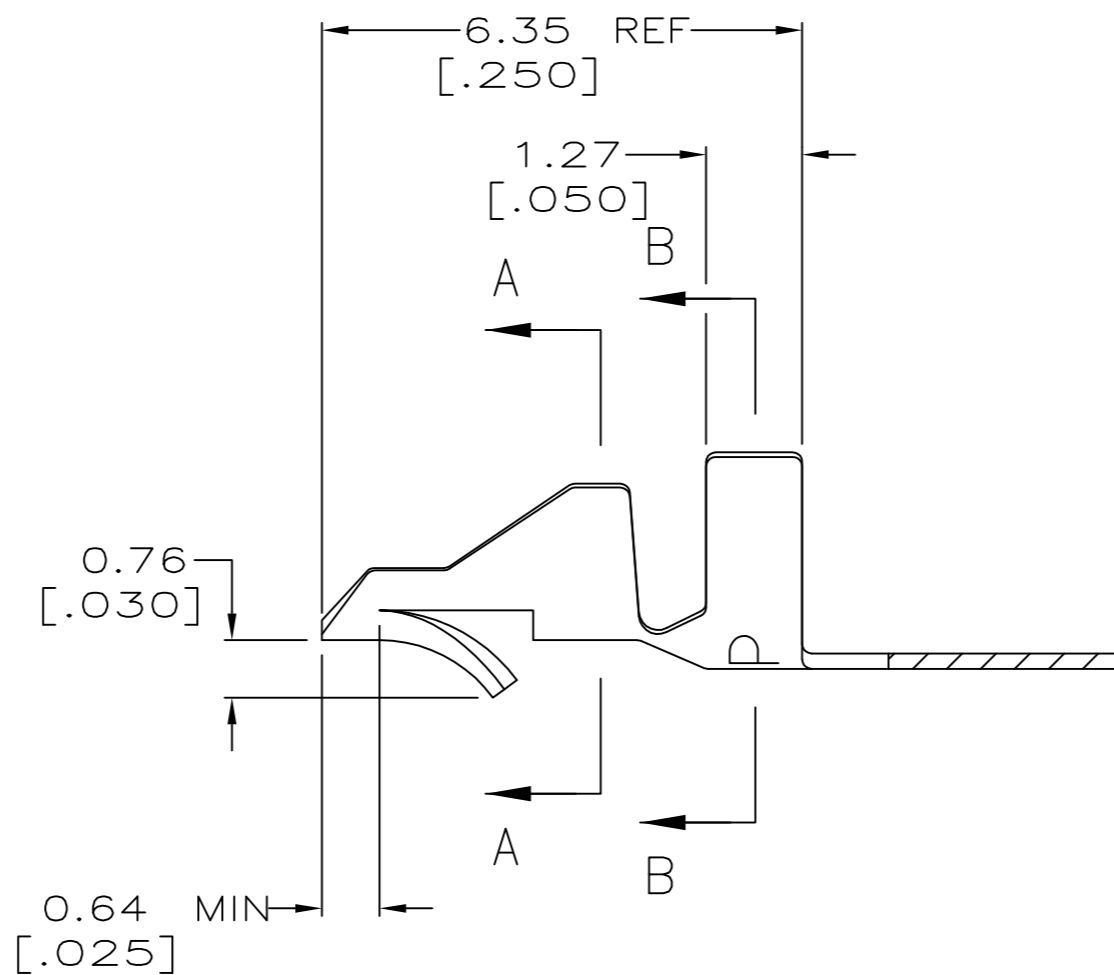
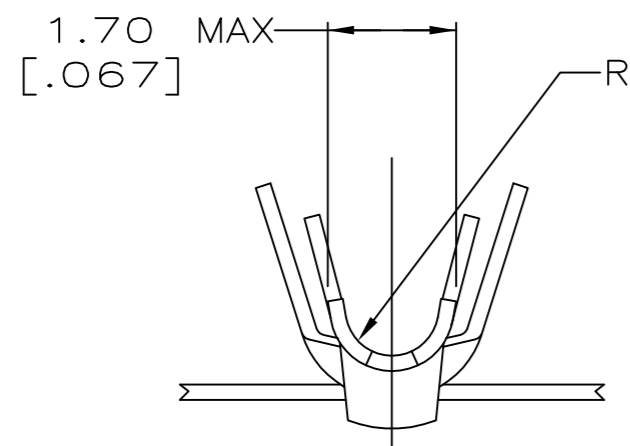

1	12	0.20 [.008] PH BRZ	3-350566-1
3	5	0.20 [.008] BRASS	350566-7
3	8	0.20 [.008] BRASS	350566-5
2	8	0.20 [.008] BRASS	350566-3
1	12	0.20 [.008] PH BRZ	350566-1
NOTES	FINISH	MATERIAL	PART NO.

THIS DRAWING IS A CONTROLLED DOCUMENT.		DWN S. CARPENTER 20AUG2003		
DIMENSIONS: INCHES		CHK J. ELLIS 20AUG2003		
TOLERANCES UNLESS OTHERWISE SPECIFIED:		APVD J. ELLIS 20AUG2003	NAME	
0 PLC ±		PRODUCT SPEC	-	
1 PLC ±		APPLICATION SPEC	MINI AMP-IN (TM)	
2 PLC ±		114-1016	SIZE A2	CAGE CODE 00779
3 PLC ± 0.13 [.005]		WEIGHT 0.000000	DRAWING NO C=350566	RESTRICTED TO -
4 PLC ±		CUSTOMER DRAWING	SCALE 10:1	SHEET 1 of 1
ANGLES ±			REV AB5	
FINISH				
SEE TABLE				

METRIC