

STRAIGHT BULKHEAD JACK CRIMP TYPE

R142.306.503

CABLE 2.6/75

Series : BNC 75

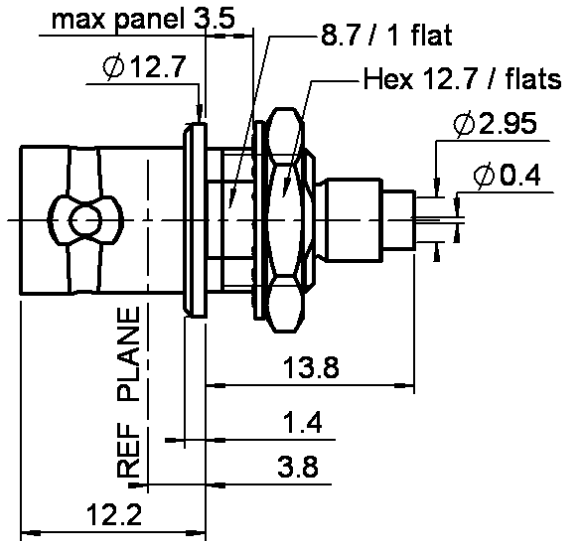

PANEL CUT OUT

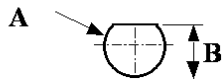

	mm	
	Maxi	mini
A	9.6	9.7
B	8.85	8.75

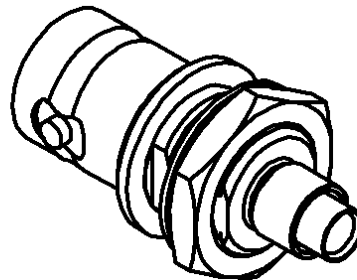
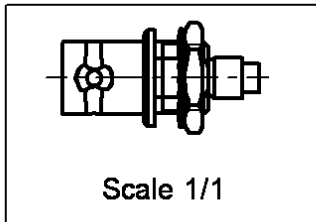

All dimensions are in mm.



COMPONENTS	MATERIALS	PLATINGS (µm)
BODY	BRASS	NICKEL 2
CENTER CONTACT	BERYLLIUM COPPER	GOLD 0.5 OVER NICKEL 2
OUTER CONTACT	-	-
INSULATOR	PTFE	-
GASKET	-	-
OTHERS PARTS	BRASS	NICKEL 2
-	-	-
-	-	-

Issue : 0123 E

In the effort to improve our products, we reserve the right to make changes judged to be necessary.



STRAIGHT BULKHEAD JACK CRIMP TYPE

R142.306.503

CABLE 2.6/75

Series : BNC 75

PACKAGING

Standard	Unit	Other
100	'W' option	Contact us

SPECIFICATION

ELECTRICAL CHARACTERISTICS

Impedance		75 Ω
Frequency		0-1.5 GHz
VSWR	1.30 +	0.000 x F(GHz) Maxi
Insertion loss		0.115 √F(GHz) dB Maxi
RF leakage	- (57 - F(GHz)) dB mini
Voltage rating		335 Veff Maxi
Dielectric withstanding voltage		1000 Veff mini
Insulation resistance		5000 MΩ mini

CABLE ASSEMBLY

Stripping	a	b	c	d	e	f
mm	3.00	10.0	0.00	0.00	5.00	1.50

Assembly instruction :

Recommended cable(s)

RG 179

RG 187

Cable retention

- pull off **40** N mini
- torque **NA** N.cm

MECHANICAL CHARACTERISTICS

Center contact retention		
Axial force – Mating end		27 N mini
Axial force – Opposite end		27 N mini
Torque		NA N.cm mini

Recommended torque		
Mating		NA N.cm
Panel nut		250 N.cm
Clamp nut		NA N.cm
A/F clamp nut		0.000 mm

Mating life		500 Cycles mini
Weight		0.000 g

TOOLING

Part Number	Description	Hexagon
.	.	.
R282.211.000	CRIMPING TOOL	4.52
R282.223.000	CRIMPING TOOL	1.73
R282.235.009	CRIMPING DIES	4.52
R282.235.011	CRIMPING DIES	1.73
R282.293.000	CRIMPING TOOL	-

OTHERS CHARACTERISTICS

ENVIRONMENTAL

Operating temperature		-65/+165 °C
Hermetic seal		NA Atm.cm3/s
Panel leakage		NA

Issue : 0123 E

In the effort to improve our products, we reserve the right to make changes judged to be necessary.



STRAIGHT BULKHEAD JACK CRIMP TYPE

R142.306.503

CABLE 2.6/75

Series : BNC 75

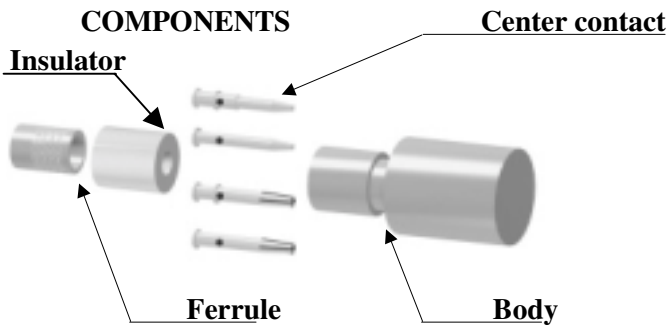

STRIPPING DIMENSIONS

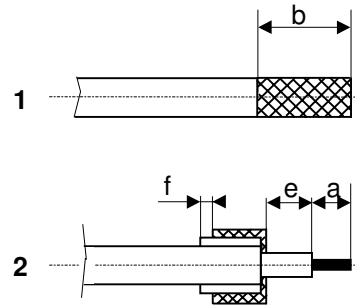

1

Strip the cable as shown in sketch 1.
Slide the ferrule until it bottoms against the sleeve.

4

Slide the center contact on until it bottoms against the insulator back nut.
Crimp the contact with crimping tool (see connector

2

Fold the braid back.

5

Mount the body onto the sub-assembly.

3

Trim the inner conductor as shown in sketch 2.
Slide insulator onto cable dielectric.

6

Crimp the body with crimping tool (see connector TDS).

Issue : 0123 E

In the effort to improve our products, we reserve the right to make changes judged to be necessary.

