

# TJA1049

## High-speed CAN transceiver with Standby mode

Rev. 6 — 15 January 2018

Product data sheet

## 1. General description

---

The TJA1049 high-speed CAN transceiver provides an interface between a Controller Area Network (CAN) protocol controller and the physical two-wire CAN bus. The transceiver is designed for high-speed CAN applications in the automotive industry, supplying the differential transmit and receive capability to (a microcontroller with) a CAN protocol controller.

The TJA1049 belongs to the third generation of high-speed CAN transceivers from NXP Semiconductors, offering significant improvements over first- and second-generation devices such as the TJA1040. It offers improved ElectroMagnetic Compatibility (EMC) and ElectroStatic Discharge (ESD) performance, and also features:

- Ideal passive behavior to the CAN bus when the supply voltage is off
- A very low-current Standby mode with bus wake-up capability
- TJA1049T/3 and TJA1049TK/3 can be interfaced directly to microcontrollers with supply voltages from 3 V to 5 V

The TJA1049 implements the CAN physical layer as defined in ISO 11898-2:2016 and SAE J2284-1 to SAE J2284-5. This implementation enables reliable communication in the CAN FD fast phase at data rates up to 5 Mbit/s.

These features make the TJA1049 an excellent choice for all types of HS-CAN networks, in nodes that require a low-power mode with wake-up capability via the CAN bus.

## 2. Features and benefits

---

### 2.1 General

- ISO 11898-2:2016 and SAE J2284-1 to SAE J2284-5 compliant
- Timing guaranteed for data rates up to 5 Mbit/s in the CAN FD fast phase
- Suitable for 12 V and 24 V systems
- Low ElectroMagnetic Emission (EME) and high ElectroMagnetic Immunity (EMI)
- $V_{IO}$  input on TJA1049T/3 and TJA1049TK/3 allows for direct interfacing with 3 V to 5 V microcontrollers
- SPLIT voltage output on TJA1049T and TJA1049TK for stabilizing recessive bus level
- Both variants available in SO8 and HVSON8 packages
- Leadless HVSON8 package (3.0 mm × 3.0 mm) with improved Automated Optical Inspection (AOI) capability
- AEC-Q100 qualified
- Dark green product (halogen free and Restriction of Hazardous Substances (RoHS) compliant)



## 2.2 Low-power management

- Very low-current Standby mode with host and bus wake-up capability
- Functional behavior predictable under all supply conditions
- Transceiver disengages from the bus when not powered up (zero load)

## 2.3 Protection

- High ESD handling capability on the bus pins
- Bus pins protected against transients in automotive environments
- Transmit Data (TXD) dominant time-out function
- Bus-dominant time-out function in Standby mode
- Undervoltage detection on pins  $V_{CC}$  and  $V_{IO}$
- Thermally protected

## 3. Quick reference data

Table 1. Quick reference data

Symbol	Parameter	Conditions	Min	Typ	Max	Unit
$V_{CC}$	supply voltage		4.75	-	5.25	V
$V_{IO}$	supply voltage on pin $V_{IO}$		2.8	-	5.5	V
$V_{uvd(VCC)}$	undervoltage detection voltage on pin $V_{CC}$		3.5	-	4.75	V
$V_{uvd(VIO)}$	undervoltage detection voltage on pin $V_{IO}$		1.3	2.0	2.7	V
$I_{CC}$	supply current	Standby mode: TJA1049T, TJA1049TK	-	10	15	$\mu$ A
		Standby mode: TJA1049T/3, TJA1049TK/3	-	-	5	$\mu$ A
		Normal mode; bus recessive	2.5	5	7.5	mA
		Normal mode; bus dominant	20	45	65	mA
$I_{IO}$	supply current on pin $V_{IO}$	Standby mode	5	-	14	$\mu$ A
		Normal mode; bus recessive	15	80	200	$\mu$ A
		Normal mode; bus dominant	-	350	1000	$\mu$ A
$V_{ESD}$	electrostatic discharge voltage	IEC 61000-4-2 at pins CANH and CANL	-8	-	+8	kV
$V_{CANH}$	voltage on pin CANH		-58	-	+58	V
$V_{CANL}$	voltage on pin CANL		-58	-	+58	V
$V_{SPLIT}$	voltage on pin SPLIT		-58	-	+58	V
$T_{vj}$	virtual junction temperature		-40	-	+150	$^{\circ}$ C

## 4. Ordering information

**Table 2. Ordering information**

Type number <sup>[1]</sup>	Package		
	Name	Description	Version
TJA1049T	SO8	plastic small outline package; 8 leads; body width 3.9 mm	SOT96-1
TJA1049TK	HVSON8	plastic thermal enhanced very thin small outline package; no leads; 8 terminals; body 3 × 3 × 0.85 mm	SOT782-1
TJA1049T/3	SO8	plastic small outline package; 8 leads; body width 3.9 mm	SOT96-1
TJA1049TK/3	HVSON8	plastic thermal enhanced very thin small outline package; no leads; 8 terminals; body 3 × 3 × 0.85 mm	SOT782-1

[1] TJA1049T and TJA1049TK with SPLIT pin; TJA1049T/3 and TJA1049TK/3 with V<sub>IO</sub> pin.

5. Block diagram

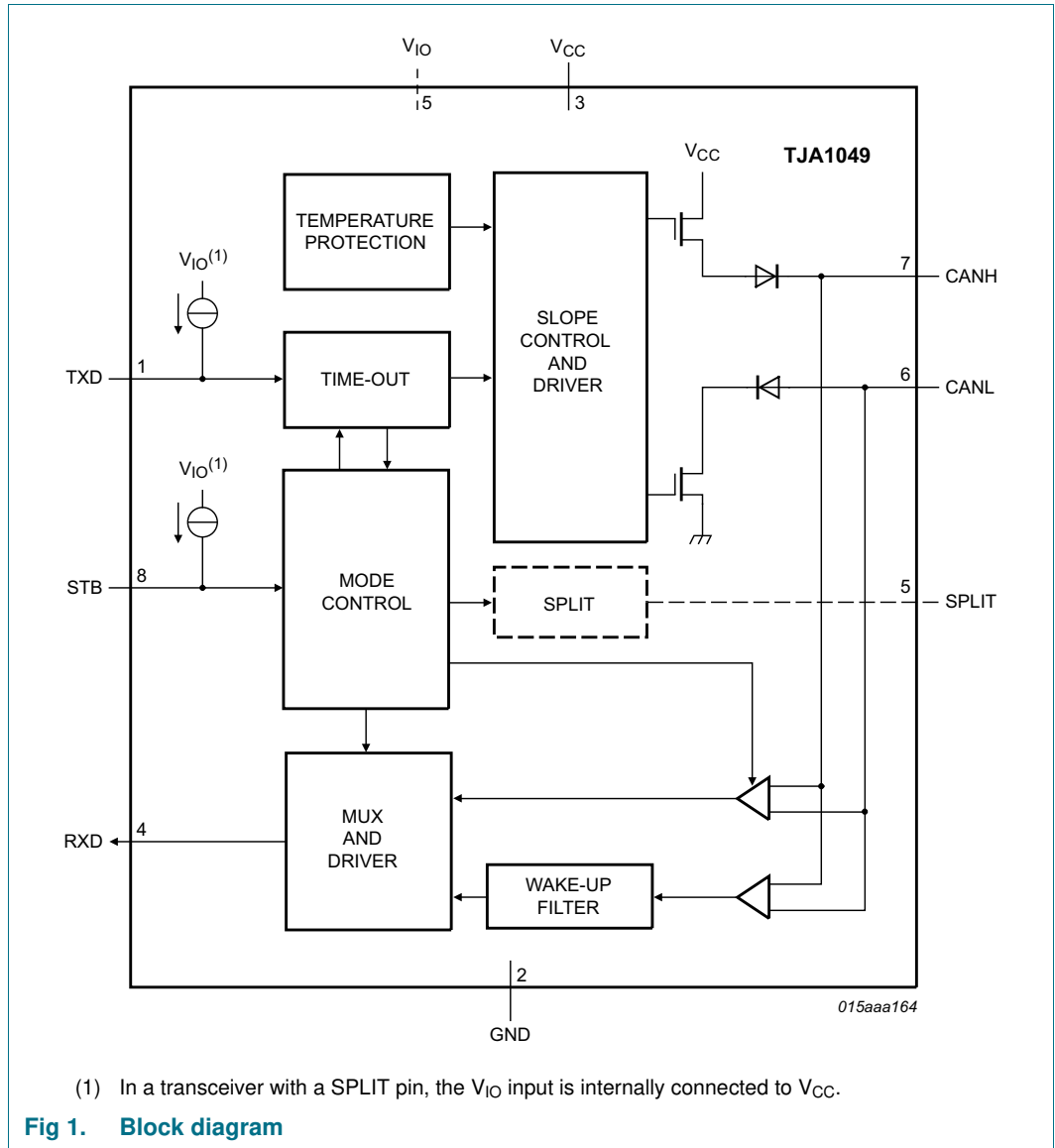

## 6. Pinning information

### 6.1 Pinning

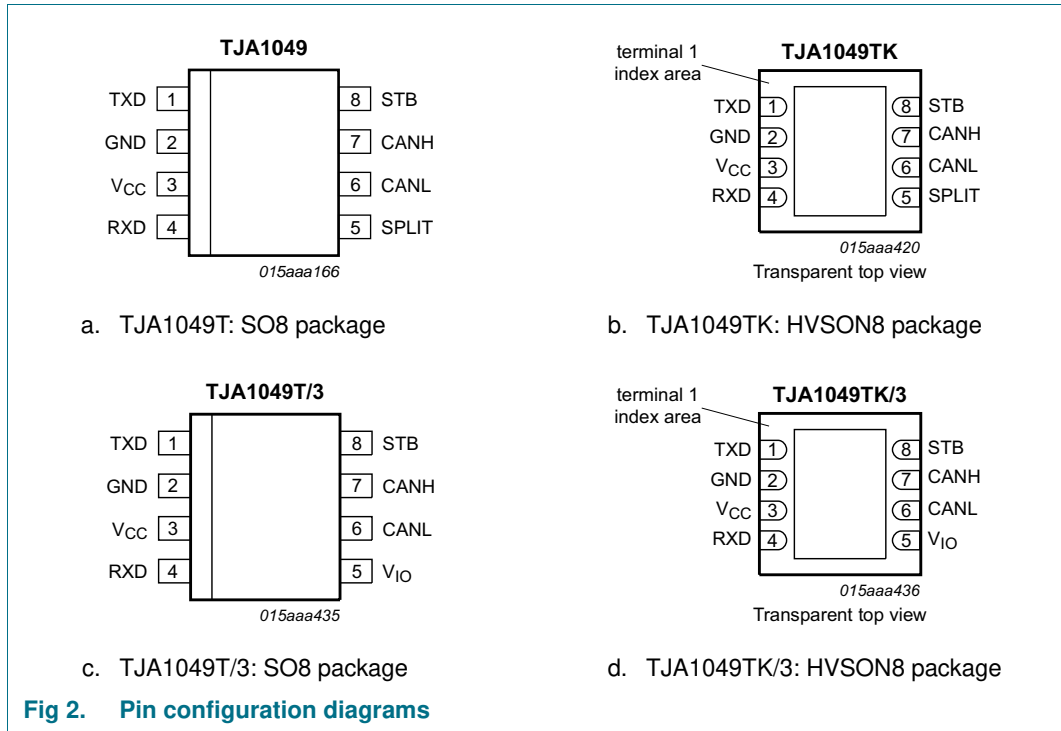

### 6.2 Pin description

Table 3. Pin description

Symbol	Pin	Description
TXD	1	transmit data input
GND	2 <sup>[1]</sup>	ground supply
V <sub>CC</sub>	3	supply voltage
RXD	4	receive data output; reads out data from the bus lines
SPLIT	5	common-mode stabilization output; TJA1049T and TJA1049TK only
V <sub>IO</sub>	5	supply voltage for I/O level adapter; TJA1049T/3 and TJA1049TK/3 only
CANL	6	LOW-level CAN bus line
CANH	7	HIGH-level CAN bus line
STB	8	Standby mode control input

[1] HVSON8 package die supply ground is connected to both the GND pin and the exposed center pad. The GND pin must be soldered to board ground. For enhanced thermal and electrical performance, it is recommended that the exposed center pad also be soldered to board ground.

## 7. Functional description

The TJA1049 is a HS-CAN stand-alone transceiver with Standby mode. It combines the functionality of the PCA82C250, PCA82C251 and TJA1040 transceivers with improved EMC and ESD handling capability and quiescent current performance. Improved slope control and high DC handling capability on the bus pins provide additional application flexibility.

The TJA1049 is available in two versions, distinguished only by the function of pin 5:

- The TJA1049T and TJA1049TK are 100 % backwards compatible with the TJA1040 when operating with a 5 V microcontroller, and also cover existing PCA82C250 and PCA82C251 applications
- The TJA1049T/3 and TJA1049TK/3 allow for direct interfacing to microcontrollers with supply voltages down to 3 V

### 7.1 Operating modes

The TJA1049 supports two operating modes, Normal and Standby, which are selectable via pin STB. See [Table 4](#) for a description of the operating modes under normal supply conditions.

**Table 4. Operating modes**

Mode	Pin STB	Pin RXD	
		LOW	HIGH
Normal	LOW	bus dominant	bus recessive
Standby	HIGH	wake-up request detected	no wake-up request detected

#### 7.1.1 Normal mode

A LOW level on pin STB selects Normal mode. In this mode, the transceiver can transmit and receive data via the bus lines CANH and CANL (see [Figure 1](#) for the block diagram). The differential receiver converts the analog data on the bus lines into digital data which is output on pin RXD. The slopes of the output signals on the bus lines are controlled internally and are optimized in a way that guarantees the lowest possible EME.

#### 7.1.2 Standby mode

A HIGH level on pin STB selects Standby mode. In Standby mode, the transceiver is not able to transmit or correctly receive data via the bus lines. The transmitter and Normal-mode receiver blocks are switched off to reduce supply current, and only a low-power differential receiver monitors the bus lines for activity. The wake-up filter on the output of the low-power receiver does not latch bus dominant states, but ensures that only bus dominant and bus recessive states that persist longer than  $t_{ftr(wake)_{bus}}$  are reflected on pin RXD, as shown in [Figure 3](#).

In Standby mode, the bus lines are biased to ground to minimize the system supply current. The low-power receiver is supplied by  $V_{IO}$ , and is capable of detecting CAN bus activity even if  $V_{IO}$  is the only supply voltage available. When pin RXD goes LOW to signal a wake-up request, a transition to Normal mode will not be triggered until STB is forced LOW.

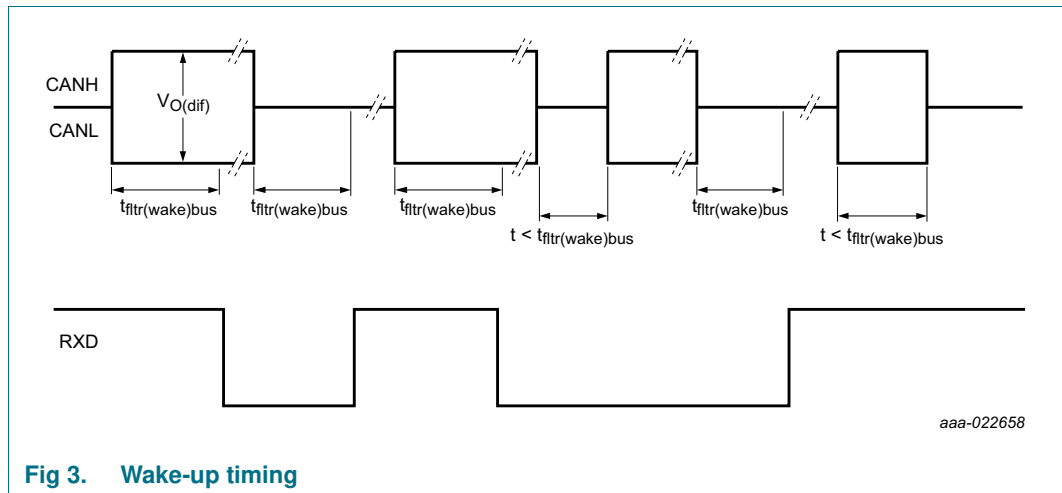

Fig 3. Wake-up timing

## 7.2 Fail-safe features

### 7.2.1 TXD dominant time-out function

A 'TXD dominant time-out' timer is started when pin TXD is set LOW. If the LOW state on pin TXD persists for longer than  $t_{to(dom)TXD}$ , the transmitter is disabled, releasing the bus lines to recessive state. This function prevents a hardware and/or software application failure from driving the bus lines to a permanent dominant state (blocking all network communications). The TXD dominant time-out timer is reset when pin TXD is set HIGH. The TXD dominant time-out time also defines the minimum possible bit rate of 40 kbit/s.

### 7.2.2 Bus dominant time-out function

In Standby mode, a 'bus dominant time-out' timer is started when the CAN bus changes from recessive to dominant state. If the dominant state on the bus persists for longer than  $t_{to(dom)bus}$ , the RXD pin is forced HIGH. This prevents a clamped dominant bus (due to a bus short-circuit or a failure in one of the other nodes on the network) generating a permanent wake-up request. The bus dominant time-out timer is reset when the CAN bus changes from dominant to recessive state.

### 7.2.3 Internal biasing of TXD and STB input pins

Pins TXD and STB have internal pull-ups to  $V_{IO}$  to ensure a safe, defined state in case one (or both) of these pins is left floating. Pull-up currents flow in these pins in all states; both pins should be held HIGH in Standby mode to minimize standby current.

### 7.2.4 Undervoltage detection on pins $V_{CC}$ and $V_{IO}$

Should  $V_{CC}$  drop below the  $V_{CC}$  undervoltage detection level,  $V_{uvd}(V_{CC})$ , the transceiver will switch to Standby mode. The logic state of pin STB will be ignored until  $V_{CC}$  has recovered.

Should  $V_{IO}$  drop below the  $V_{IO}$  undervoltage detection level,  $V_{uvd}(V_{IO})$ , the transceiver will switch off and disengage from the bus (zero load) until  $V_{IO}$  has recovered.

**7.2.5 Overtemperature protection**

The output drivers are protected against overtemperature conditions. If the virtual junction temperature exceeds the shutdown junction temperature,  $T_{j(sd)}$ , the output drivers will be disabled until the virtual junction temperature falls below  $T_{j(sd)}$  and TXD becomes recessive again. Including the TXD condition ensures that output driver oscillation due to temperature drift is avoided.

**7.3 SPLIT output pin and  $V_{IO}$  supply pin**

Two versions of the TJA1049 are available, only differing in the function of a single pin. Pin 5 is either a SPLIT output pin or a  $V_{IO}$  supply pin.

**7.3.1 SPLIT pin**

Using the SPLIT pin on the TJA1049T or TJA1049TK in conjunction with a split termination network (see [Figure 4](#) and [Figure 7](#)) can help to stabilize the recessive voltage level on the bus. This will reduce EME in networks with DC leakage to ground (e.g. from deactivated nodes with poor bus leakage performance). In Normal mode, pin SPLIT delivers a DC output voltage of  $0.5V_{CC}$ . In Standby mode or when  $V_{CC}$  is off, pin SPLIT is floating.

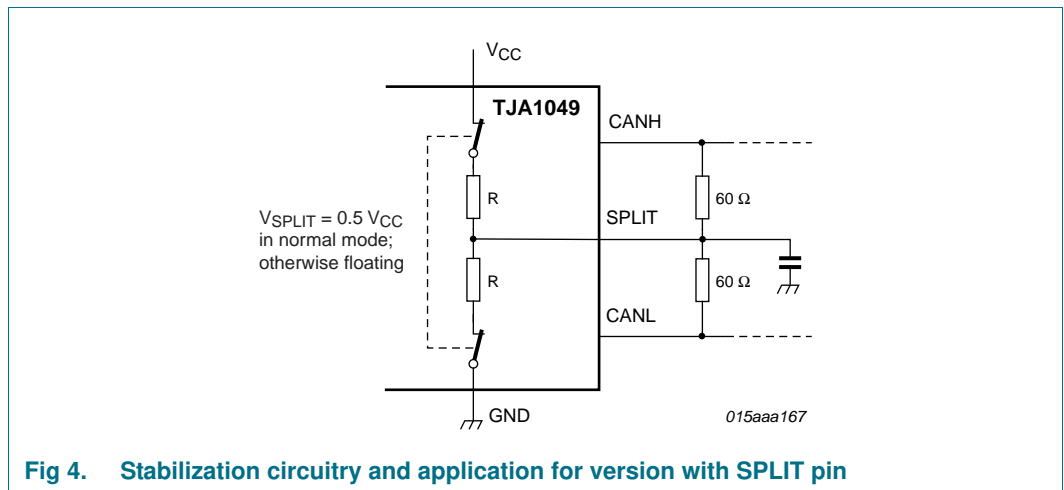

**Fig 4. Stabilization circuitry and application for version with SPLIT pin**

**7.3.2  $V_{IO}$  supply pin**

Pin  $V_{IO}$  on the TJA1049T/3 and TJA1049TK/3 should be connected to the microcontroller supply voltage (see [Figure 8](#)). This will adjust the signal levels of pins TXD, RXD and STB to the I/O levels of the microcontroller. Pin  $V_{IO}$  also provides the internal supply voltage for the low-power differential receiver of the transceiver. For applications running in low-power mode, this allows the bus lines to be monitored for activity even if there is no supply voltage on pin  $V_{CC}$ .

For versions of the TJA1049 without a  $V_{IO}$  pin, the  $V_{IO}$  input is internally connected to  $V_{CC}$ . This sets the signal levels of pins TXD, RXD and STB to levels compatible with 5 V microcontrollers.



## 8. Limiting values

**Table 5. Limiting values**

In accordance with the Absolute Maximum Rating System (IEC 60134). All voltages are referenced to GND.

Symbol	Parameter	Conditions	Min	Max	Unit
V <sub>x</sub>	voltage on pin x <sup>[1]</sup>	on pins CANH, CANL and SPLIT	-58	+58	V
		on any other pin	-0.3	+7	V
V <sub>(CANH-CANL)</sub>	voltage between pin CANH and pin CANL		-27	+27	V
V <sub>trt</sub>	transient voltage	on pins CANH, CANL <sup>[2]</sup>			
		pulse 1	-100	-	V
		pulse 2a	-	75	V
		pulse 3a	-150	-	V
		pulse 3b	-	100	V
V <sub>ESD</sub>	electrostatic discharge voltage	IEC 61000-4-2 (150 pF, 330 Ω) <sup>[3]</sup>			
		at pins CANH and CANL	-8	+8	kV
		Human Body Model (HBM); 100 pF, 1.5 kΩ <sup>[4]</sup>			
		at pins CANH and CANL	-8	+8	kV
		at any other pin	-4	+4	kV
		Machine Model (MM); 200 pF, 0.75 μH, 10 Ω <sup>[5]</sup>			
		at any pin	-300	+300	V
		Charged Device Model (CDM); field Induced charge; 4 pF <sup>[6]</sup>			
at corner pins	-750	+750	V		
at any pin	-500	+500	V		
T <sub>vj</sub>	virtual junction temperature	<sup>[7]</sup>	-40	+150	°C
T <sub>stg</sub>	storage temperature		-55	+150	°C

- [1] The device can sustain voltages up to the specified values over the product lifetime, provided applied voltages (including transients) never exceed these values.
- [2] According to IEC TS 62228 (2007), Section 4.2.4; parameters for standard pulses defined in ISO7637 part 2: 2004-06.
- [3] According to IEC TS 62228 (2007), Section 4.3; DIN EN 61000-4-2.
- [4] According to AEC-Q100-002.
- [5] According to AEC-Q100-003.
- [6] According to AEC-Q100-011 Rev-C1. The classification level is C4B.
- [7] In accordance with IEC 60747-1. An alternative definition of virtual junction temperature is:  $T_{vj} = T_{amb} + P \times R_{th(vj-a)}$ , where  $R_{th(vj-a)}$  is a fixed value to be used for the calculation of  $T_{vj}$ . The rating for  $T_{vj}$  limits the allowable combinations of power dissipation (P) and ambient temperature ( $T_{amb}$ ).

## 9. Thermal characteristics

**Table 6. Thermal characteristics**

According to IEC 60747-1.

Symbol	Parameter	Conditions	Typ	Unit
R <sub>th(j-a)</sub>	thermal resistance from junction to ambient	SO8 package; in free air	145	K/W
		HVSON8 package; in free air	50	K/W

## 10. Static characteristics

**Table 7. Static characteristics**

$T_{vj} = -40\text{ }^{\circ}\text{C}$  to  $+150\text{ }^{\circ}\text{C}$ ;  $V_{CC} = 4.75\text{ V}$  to  $5.25\text{ V}$ ;  $V_{IO} = 2.8\text{ V}$  to  $5.5\text{ V}$  [1];  $R_L = 60\text{ }\Omega$  unless specified otherwise; All voltages are defined with respect to ground. Positive currents flow into the IC. [2]

Symbol	Parameter	Conditions	Min	Typ	Max	Unit
<b>Supply; pin V<sub>CC</sub></b>						
V <sub>CC</sub>	supply voltage		4.75	-	5.25	V
I <sub>CC</sub>	supply current	Standby mode				
		TJA1049T or TJA1049TK; includes I <sub>IO</sub> ; V <sub>TXD</sub> = V <sub>IO</sub> [3]	-	10	15	μA
		TJA1049T/3 or TJA1049TK/3	-	-	5	μA
		Normal mode				
		recessive; V <sub>TXD</sub> = V <sub>IO</sub> [3]	2.5	5	7.5	mA
		dominant; V <sub>TXD</sub> = 0 V	20	45	65	mA
V <sub>uvd(VCC)</sub>	undervoltage detection voltage on pin V <sub>CC</sub>	dominant; V <sub>TXD</sub> = 0 V; short circuit on bus lines; -3 V < (V <sub>CANH</sub> = V <sub>CANL</sub> ) < +18 V	2.5	77.5	107.5	mA
			3.5	-	4.75	V
<b>I/O level adapter supply; pin V<sub>IO</sub> [1]</b>						
V <sub>IO</sub>	supply voltage on pin V <sub>IO</sub>		2.8	-	5.5	V
I <sub>IO</sub>	supply current on pin V <sub>IO</sub>	Standby mode; V <sub>TXD</sub> = V <sub>IO</sub> [3]	5	-	14	μA
		Normal mode				
		recessive; V <sub>TXD</sub> = V <sub>IO</sub> [3]	15	80	200	μA
V <sub>uvd(VIO)</sub>	undervoltage detection voltage on pin V <sub>IO</sub>	dominant; V <sub>TXD</sub> = 0 V	-	350	1000	μA
			1.3	2.0	2.7	V
<b>Standby mode control input; pin STB</b>						
V <sub>IH</sub>	HIGH-level input voltage	[4]	0.7V <sub>IO</sub> [3]	-	V <sub>IO</sub> + 0.3	V
V <sub>IL</sub>	LOW-level input voltage		-0.3	-	0.3V <sub>IO</sub> [3]	V
I <sub>IH</sub>	HIGH-level input current	V <sub>STB</sub> = V <sub>IO</sub> [3]	-1	-	+1	μA
I <sub>IL</sub>	LOW-level input current	V <sub>STB</sub> = 0 V	-15	-	-1	μA
<b>CAN transmit data input; pin TXD</b>						
V <sub>IH</sub>	HIGH-level input voltage	[4]	0.7V <sub>IO</sub> [3]	-	V <sub>IO</sub> [3] + 0.3	V
V <sub>IL</sub>	LOW-level input voltage		-0.3	-	0.3V <sub>IO</sub> [3]	V
I <sub>IH</sub>	HIGH-level input current	V <sub>TXD</sub> = V <sub>IO</sub> [3]	-5	-	+5	μA
I <sub>IL</sub>	LOW-level input current	V <sub>TXD</sub> = 0 V	-260	-150	-30	μA
C <sub>i</sub>	input capacitance	[5]	-	5	10	pF
<b>CAN receive data output; pin RXD</b>						
I <sub>OH</sub>	HIGH-level output current	TJA1049T or TJA1049TK; V <sub>RXD</sub> = V <sub>CC</sub> - 0.4 V	-8	-3	-1	mA
		TJA1049T/3 or TJA1049TK/3; V <sub>RXD</sub> = V <sub>IO</sub> - 0.4 V	-9	-3	-1	mA

**Table 7. Static characteristics ...continued**

$T_{vj} = -40\text{ }^{\circ}\text{C}$  to  $+150\text{ }^{\circ}\text{C}$ ;  $V_{CC} = 4.75\text{ V}$  to  $5.25\text{ V}$ ;  $V_{IO} = 2.8\text{ V}$  to  $5.5\text{ V}$  [1];  $R_L = 60\text{ }\Omega$  unless specified otherwise; All voltages are defined with respect to ground. Positive currents flow into the IC. [2]

Symbol	Parameter	Conditions	Min	Typ	Max	Unit
$I_{OL}$	LOW-level output current	$V_{RXD} = 0.4\text{ V}$ ; bus dominant	1	-	12	mA
<b>Bus lines; pins CANH and CANL</b>						
$V_{O(dom)}$	dominant output voltage	$V_{TXD} = 0\text{ V}$ ; $t < t_{to(dom)TXD}$				
		pin CANH; $R_L = 50\text{ }\Omega$ to $65\text{ }\Omega$	2.75	3.5	4.5	V
		pin CANL; $R_L = 50\text{ }\Omega$ to $65\text{ }\Omega$	0.5	1.5	2.25	V
$V_{dom(TX)sym}$	transmitter dominant voltage symmetry	$V_{dom(TX)sym} = V_{CC} - V_{CANH} - V_{CANL}$	-400	-	+400	mV
$V_{TXsym}$	transmitter voltage symmetry	$V_{TXsym} = V_{CANH} + V_{CANL}$ ; $C_{SPLIT} = 4.7\text{ nF}$ ; $f_{TXD} = 250\text{ kHz}$ , $1\text{ MHz}$ and $2.5\text{ MHz}$	0.9 $V_{CC}$ [5] [6]	-	1.1 $V_{CC}$	V
$V_{O(dif)}$	differential output voltage	dominant; Normal mode; $V_{TXD} = 0\text{ V}$ ; $t < t_{to(dom)TXD}$ ; $V_{CC} = 4.75\text{ V}$ to $5.25\text{ V}$				
		$R_L = 45\text{ }\Omega$ to $70\text{ }\Omega$	1.5	-	3	V
		$R_L = 2240\text{ }\Omega$	1.5	-	5	V
		recessive; no load				
		Normal mode: $V_{TXD} = V_{IO}$ [3]	-50	-	+50	mV
		Standby mode	-0.2	-	+0.2	V
$V_{O(rec)}$	recessive output voltage	Normal mode; $V_{TXD} = V_{IO}$ [3]; no load	2	0.5 $V_{CC}$	3	V
		Standby mode; no load	-0.1	-	+0.1	V
$V_{th(RX)dif}$	differential receiver threshold voltage	$-12\text{ V} \leq V_{CANL} \leq +12\text{ V}$ ; $-12\text{ V} \leq V_{CANH} \leq +12\text{ V}$				
		Normal mode	0.5	-	0.9	V
		Standby mode	0.4	-	1.15	V
$V_{rec(RX)}$	receiver recessive voltage	$-12\text{ V} \leq V_{CANL} \leq +12\text{ V}$ ; $-12\text{ V} \leq V_{CANH} \leq +12\text{ V}$				
		Normal mode	-4	-	0.5	V
		Standby mode	-4	-	0.4	V
$V_{dom(RX)}$	receiver dominant voltage	$-12\text{ V} \leq V_{CANL} \leq +12\text{ V}$ ; $-12\text{ V} \leq V_{CANH} \leq +12\text{ V}$				
		Normal mode	0.9	-	9.0	V
		Standby mode	1.15	-	9.0	V
$V_{hys(RX)dif}$	differential receiver hysteresis voltage	$-12\text{ V} \leq V_{CANL} \leq +12\text{ V}$ ; $-12\text{ V} \leq V_{CANH} \leq +12\text{ V}$ ; Normal mode	100	-	300	mV
$I_{O(sc)dom}$	dominant short-circuit output current	$V_{TXD} = 0\text{ V}$ ; $t < t_{to(dom)TXD}$ ; $V_{CC} = 5\text{ V}$				
		pin CANH; $V_{CANH} = -15\text{ V}$ to $+40\text{ V}$	-100	-70	-40	mA
		pin CANL; $V_{CANL} = -15\text{ V}$ to $+40\text{ V}$	40	70	100	mA
$I_{O(sc)rec}$	recessive short-circuit output current	Normal mode; $V_{TXD} = V_{IO}$ [3] $V_{CANH} = V_{CANL} = -27\text{ V}$ to $+32\text{ V}$	-5	-	+5	mA
$I_L$	leakage current	$V_{CC} = V_{IO} = 0\text{ V}$ or $V_{CC} = V_{IO} =$ shorted to GND via $47\text{ k}\Omega$ ; $V_{CANH} = V_{CANL} = 5\text{ V}$	-3	-	+3	$\mu\text{A}$
$R_i$	input resistance	$-2\text{ V} \leq V_{CANL} \leq +7\text{ V}$ ; $-2\text{ V} \leq V_{CANH} \leq +7\text{ V}$	9	15	28	$\text{k}\Omega$

**Table 7. Static characteristics ...continued**

$T_{vj} = -40\text{ }^{\circ}\text{C}$  to  $+150\text{ }^{\circ}\text{C}$ ;  $V_{CC} = 4.75\text{ V}$  to  $5.25\text{ V}$ ;  $V_{IO} = 2.8\text{ V}$  to  $5.5\text{ V}$ <sup>[1]</sup>;  $R_L = 60\ \Omega$  unless specified otherwise; All voltages are defined with respect to ground. Positive currents flow into the IC.<sup>[2]</sup>

Symbol	Parameter	Conditions	Min	Typ	Max	Unit
$\Delta R_i$	input resistance deviation	$0\text{ V} \leq V_{CANL} \leq +5\text{ V}$ ; $0\text{ V} \leq V_{CANH} \leq +5\text{ V}$	-3	-	+3	%
$R_{i(dif)}$	differential input resistance	$-2\text{ V} \leq V_{CANL} \leq +7\text{ V}$ ; $-2\text{ V} \leq V_{CANH} \leq +7\text{ V}$	19	30	52	k $\Omega$
$C_{i(cm)}$	common-mode input capacitance		[5]	-	20	pF
$C_{i(dif)}$	differential input capacitance		[5]	-	10	pF
<b>Common mode stabilization output, pin SPLIT; only relevant for TJA1049T and TJA1049TK</b>						
$V_O$	output voltage	Normal mode; $I_{SPLIT} = -500\ \mu\text{A}$ to $+500\ \mu\text{A}$	$0.3V_{CC}$	$0.5V_{CC}$	$0.7V_{CC}$	V
		Normal mode; $R_L = 1\text{ M}\Omega$	$0.45V_{CC}$	$0.5V_{CC}$	$0.55V_{CC}$	V
$I_L$	leakage current	Standby mode; $V_{SPLIT} = -58\text{ V}$ to $+58\text{ V}$	-5	-	+5	$\mu\text{A}$
<b>Temperature detection</b>						
$T_{j(sd)}$	shutdown junction temperature		[5]	190	-	$^{\circ}\text{C}$

- [1] Only TJA1049T/3 and TJA1049TK/3 have a  $V_{IO}$  pin; in TJA1049T and TJA1049TK, the  $V_{IO}$  input is internally connected to  $V_{CC}$ .
- [2] All parameters are guaranteed over the virtual junction temperature range by design. Factory testing uses correlated test conditions to cover the specified temperature and power supply voltage range.
- [3]  $V_{IO} = V_{CC}$  in non- $V_{IO}$  product variants TJA1049T and TJA1049TK.
- [4] Maximum value assumes  $V_{CC} < V_{IO}$ ; if  $V_{CC} > V_{IO}$ , the maximum value will be  $V_{CC} + 0.3\text{ V}$ .
- [5] Not tested in production; guaranteed by design.
- [6] The test circuit used to measure the bus output voltage symmetry (which includes  $C_{SPLIT}$ ) is shown in [Figure 10](#).

## 11. Dynamic characteristics

**Table 8. Dynamic characteristics**

$T_{vj} = -40\text{ }^{\circ}\text{C}$  to  $+150\text{ }^{\circ}\text{C}$ ;  $V_{CC} = 4.75\text{ V}$  to  $5.25\text{ V}$ ;  $V_{IO} = 2.8\text{ V}$  to  $5.5\text{ V}$ <sup>[1]</sup>;  $R_L = 60\ \Omega$  unless specified otherwise. All voltages are defined with respect to ground. Positive currents flow into the IC.<sup>[2]</sup>

Symbol	Parameter	Conditions	Min	Typ	Max	Unit
<b>Transceiver timing; pins CANH, CANL, TXD and RXD; see <a href="#">Figure 9</a> and <a href="#">Figure 5</a></b>						
$t_{d(TXD-busdom)}$	delay time from TXD to bus dominant	Normal mode	-	65	-	ns
$t_{d(TXD-busrec)}$	delay time from TXD to bus recessive	Normal mode	-	90	-	ns
$t_{d(busdom-RXD)}$	delay time from bus dominant to RXD	Normal mode	-	60	-	ns
$t_{d(busrec-RXD)}$	delay time from bus recessive to RXD	Normal mode	-	65	-	ns
$t_{d(TXDL-RXDL)}$	propagation delay from TXD to RXD	versions with SPLIT pin; Normal mode	60	-	220	ns
		versions with $V_{IO}$ pin Normal mode	60	-	250	ns

**Table 8. Dynamic characteristics ...continued**

$T_{vj} = -40\text{ }^{\circ}\text{C}$  to  $+150\text{ }^{\circ}\text{C}$ ;  $V_{CC} = 4.75\text{ V}$  to  $5.25\text{ V}$ ;  $V_{IO} = 2.8\text{ V}$  to  $5.5\text{ V}$ <sup>[1]</sup>;  $R_L = 60\text{ }\Omega$  unless specified otherwise. All voltages are defined with respect to ground. Positive currents flow into the IC.<sup>[2]</sup>

Symbol	Parameter	Conditions	Min	Typ	Max	Unit
$t_{d(\text{TXDH-RXDH})}$	propagation delay from TXD to RXD	versions with SPLIT pin; Normal mode	60	-	220	ns
		versions with $V_{IO}$ pin; Normal mode	60	-	250	ns
$t_{\text{bit}(\text{bus})}$	transmitted recessive bit width	$t_{\text{bit}(\text{TXD})} = 500\text{ ns}$	<sup>[3]</sup> 435	-	530	ns
		$t_{\text{bit}(\text{TXD})} = 200\text{ ns}$	<sup>[3]</sup> 155	-	210	ns
$t_{\text{bit}(\text{RXD})}$	bit time on pin RXD	$t_{\text{bit}(\text{TXD})} = 500\text{ ns}$	<sup>[3]</sup> 400	-	550	ns
		$t_{\text{bit}(\text{TXD})} = 200\text{ ns}$	<sup>[3]</sup> 120	-	220	ns
$\Delta t_{\text{rec}}$	receiver timing symmetry	$t_{\text{bit}(\text{TXD})} = 500\text{ ns}$	-65	-	+40	ns
		$t_{\text{bit}(\text{TXD})} = 200\text{ ns}$	-45	-	+15	ns
$t_{\text{to}(\text{dom})\text{TXD}}$	TXD dominant time-out time	$V_{\text{TXD}} = 0\text{ V}$ ; Normal mode	<sup>[4]</sup> 0.3	2	5	ms
$t_{\text{to}(\text{dom})\text{bus}}$	bus dominant time-out time	Standby mode	0.3	2	5	ms
$t_{\text{ftr}(\text{wake})\text{bus}}$	bus wake-up filter time	version with SPLIT pin; Standby mode	0.5	1	3	$\mu\text{s}$
		versions with $V_{IO}$ pin; Standby mode	0.5	1.5	5	$\mu\text{s}$
$t_{\text{d}(\text{stb-norm})}$	standby to normal mode delay time		7	25	47	$\mu\text{s}$

- [1] Only TJA1049T/3 and TJA1049TK/3 have a  $V_{IO}$  pin; in the TJA1049T and TJA1049TK, the  $V_{IO}$  input is internally connected to  $V_{CC}$ .
- [2] All parameters are guaranteed over the virtual junction temperature range by design. Factory testing uses correlated test conditions to cover the specified temperature and power supply voltage range.
- [3] See [Figure 6](#).
- [4] Minimum value of 0.8 ms required according to SAE J2284; 0.3 ms is allowed according to ISO11898-2:2016 for legacy devices.

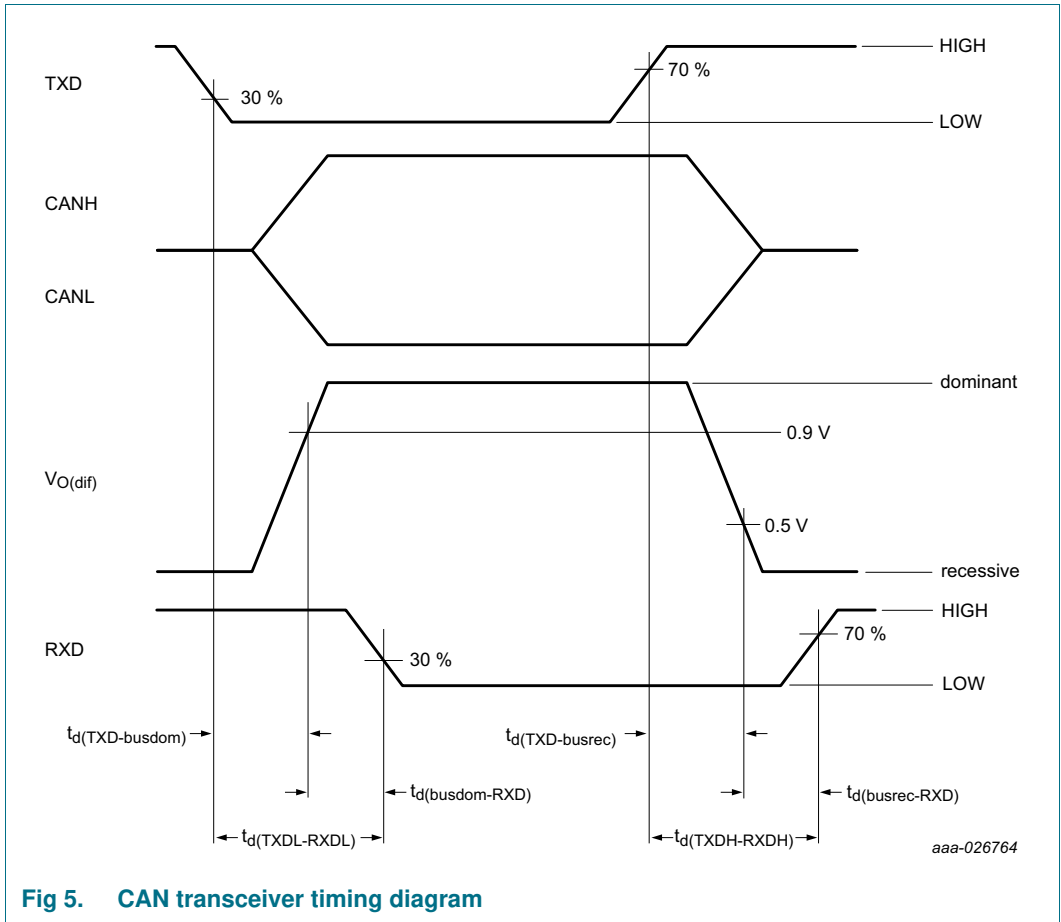

Fig 5. CAN transceiver timing diagram

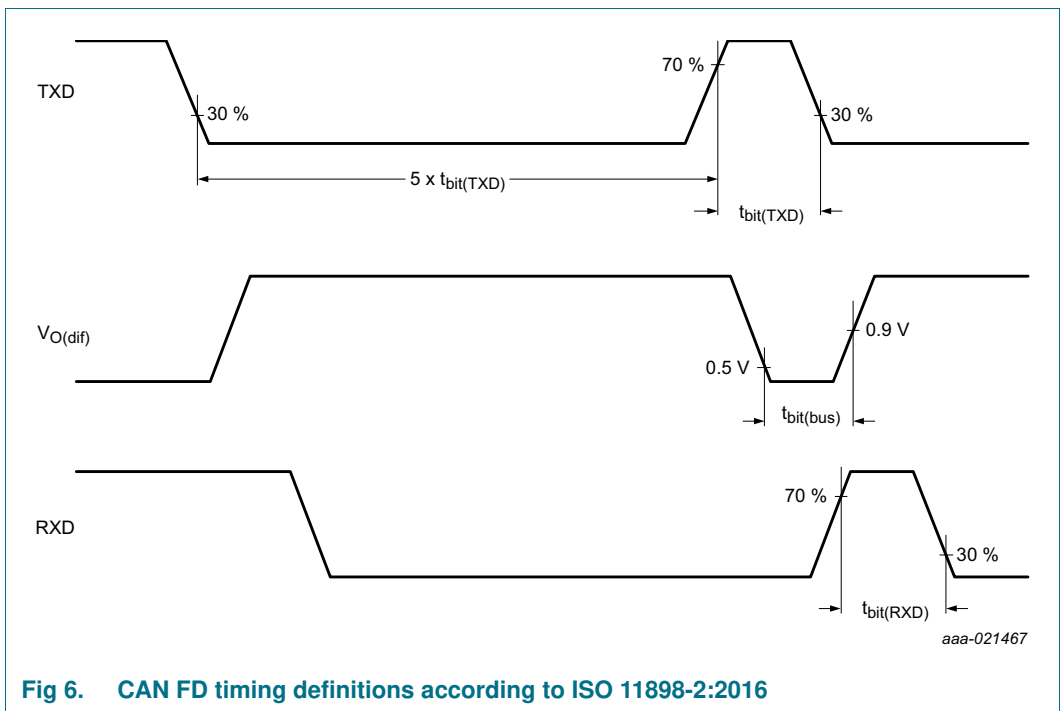
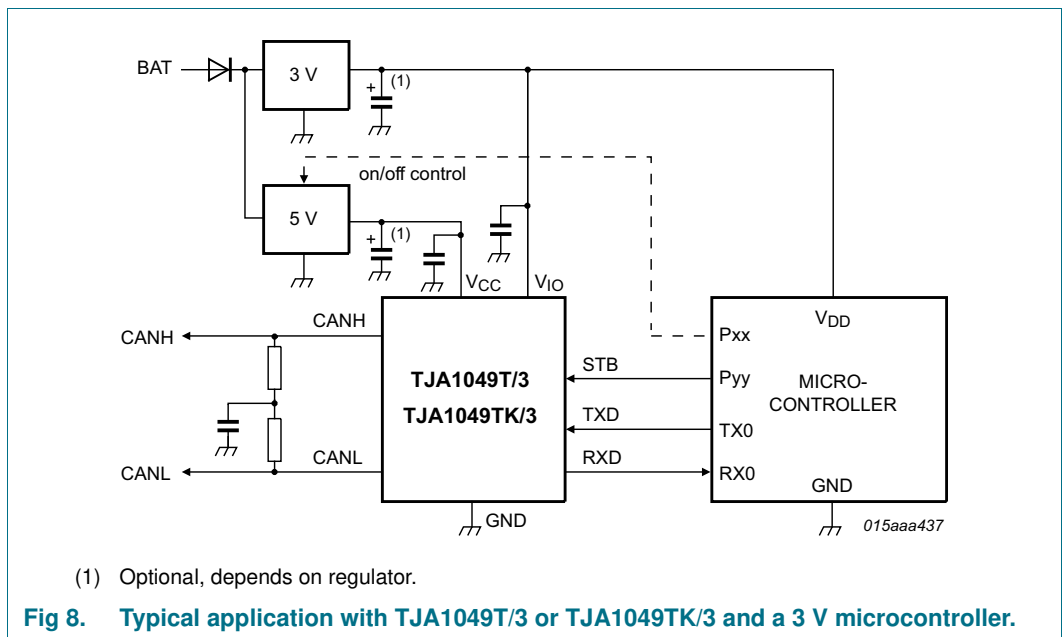
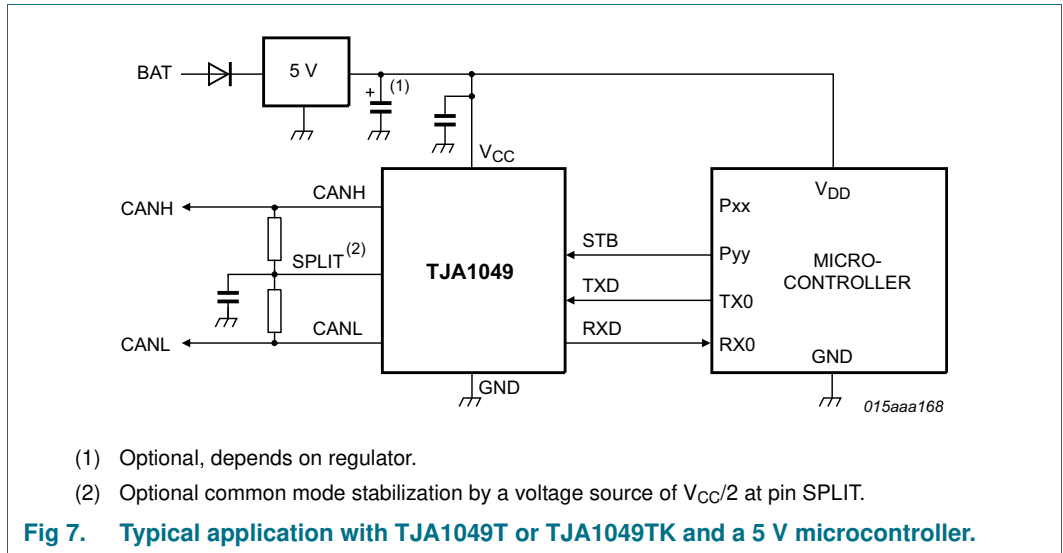

Fig 6. CAN FD timing definitions according to ISO 11898-2:2016

## 12. Application information

### 12.1 Application diagrams



### 12.2 Application hints

Further information on the application of the TJA1049 can be found in NXP application hints *AH1021 Application Hints - High-speed CAN transceiver TJA1049*.

13. Test information

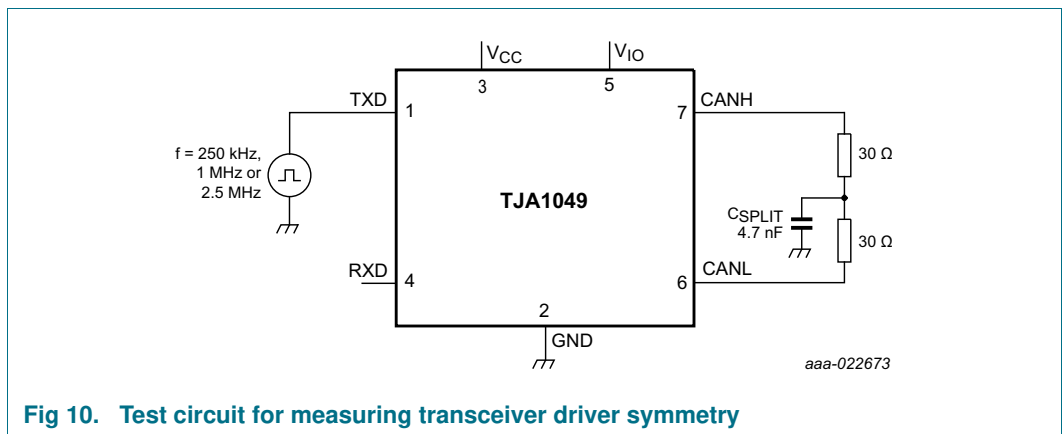
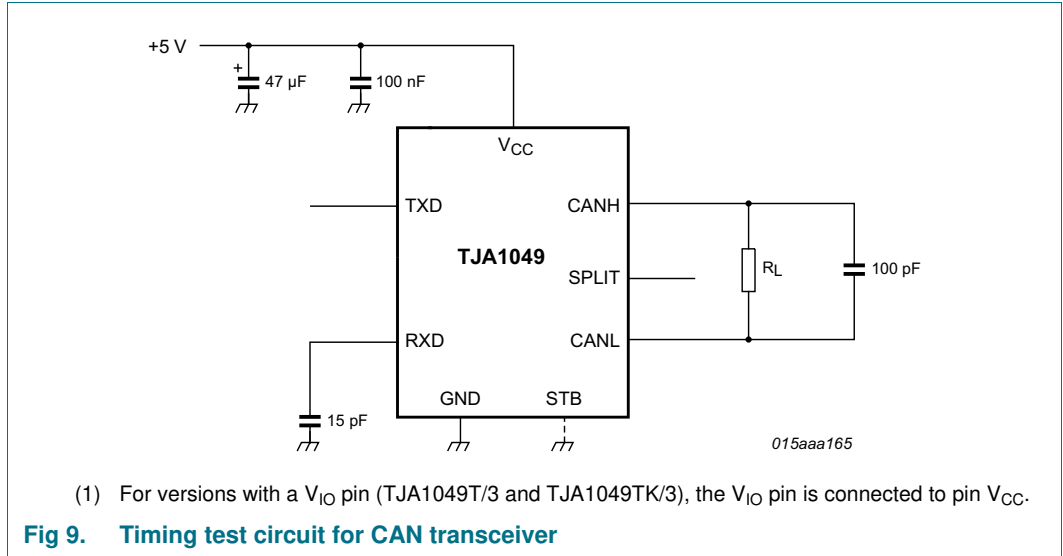

13.1 Quality information

This product has been qualified in accordance with the Automotive Electronics Council (AEC) standard *Q100 Rev-G - Failure mechanism based stress test qualification for integrated circuits*, and is suitable for use in automotive applications.



14. Package outline

SO8: plastic small outline package; 8 leads; body width 3.9 mm

SOT96-1

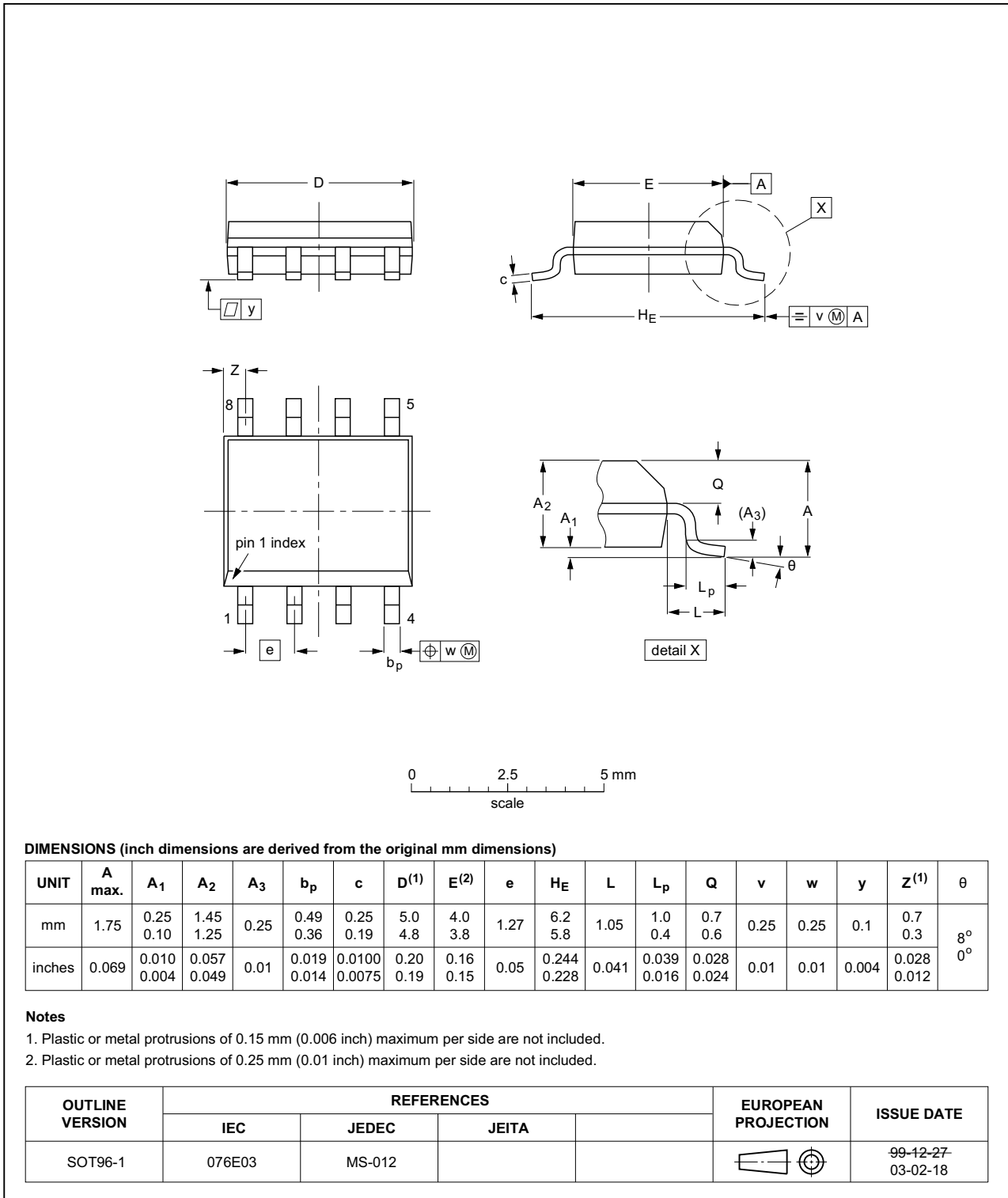

Fig 11. Package outline SOT96-1 (SO8)

HVSON8: plastic thermal enhanced very thin small outline package; no leads;  
8 terminals; body 3 x 3 x 0.85 mm

SOT782-1

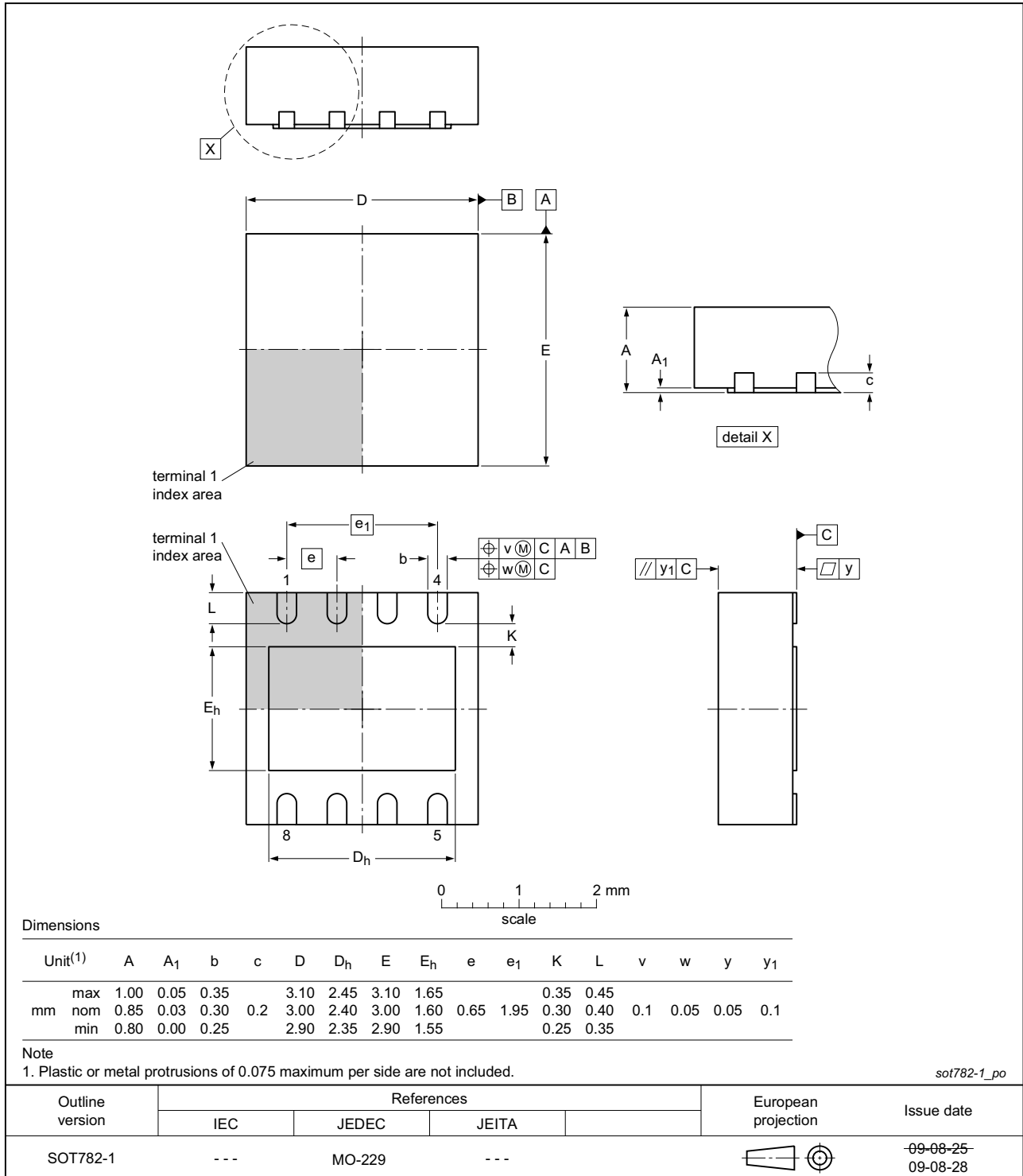

Fig 12. Package outline SOT782-1 (HVSON8)

## 15. Handling information

All input and output pins are protected against ElectroStatic Discharge (ESD) under normal handling. When handling ensure that the appropriate precautions are taken as described in *JESD625-A* or equivalent standards.

## 16. Soldering of SMD packages

This text provides a very brief insight into a complex technology. A more in-depth account of soldering ICs can be found in Application Note *AN10365 "Surface mount reflow soldering description"*.

### 16.1 Introduction to soldering

Soldering is one of the most common methods through which packages are attached to Printed Circuit Boards (PCBs), to form electrical circuits. The soldered joint provides both the mechanical and the electrical connection. There is no single soldering method that is ideal for all IC packages. Wave soldering is often preferred when through-hole and Surface Mount Devices (SMDs) are mixed on one printed wiring board; however, it is not suitable for fine pitch SMDs. Reflow soldering is ideal for the small pitches and high densities that come with increased miniaturization.

### 16.2 Wave and reflow soldering

Wave soldering is a joining technology in which the joints are made by solder coming from a standing wave of liquid solder. The wave soldering process is suitable for the following:

- Through-hole components
- Leaded or leadless SMDs, which are glued to the surface of the printed circuit board

Not all SMDs can be wave soldered. Packages with solder balls, and some leadless packages which have solder lands underneath the body, cannot be wave soldered. Also, leaded SMDs with leads having a pitch smaller than ~0.6 mm cannot be wave soldered, due to an increased probability of bridging.

The reflow soldering process involves applying solder paste to a board, followed by component placement and exposure to a temperature profile. Leaded packages, packages with solder balls, and leadless packages are all reflow solderable.

Key characteristics in both wave and reflow soldering are:

- Board specifications, including the board finish, solder masks and vias
- Package footprints, including solder thieves and orientation
- The moisture sensitivity level of the packages
- Package placement
- Inspection and repair
- Lead-free soldering versus SnPb soldering

### 16.3 Wave soldering

Key characteristics in wave soldering are:

- Process issues, such as application of adhesive and flux, clinching of leads, board transport, the solder wave parameters, and the time during which components are exposed to the wave
- Solder bath specifications, including temperature and impurities

### 16.4 Reflow soldering

Key characteristics in reflow soldering are:

- Lead-free versus SnPb soldering; note that a lead-free reflow process usually leads to higher minimum peak temperatures (see [Figure 13](#)) than a SnPb process, thus reducing the process window
- Solder paste printing issues including smearing, release, and adjusting the process window for a mix of large and small components on one board
- Reflow temperature profile; this profile includes preheat, reflow (in which the board is heated to the peak temperature) and cooling down. It is imperative that the peak temperature is high enough for the solder to make reliable solder joints (a solder paste characteristic). In addition, the peak temperature must be low enough that the packages and/or boards are not damaged. The peak temperature of the package depends on package thickness and volume and is classified in accordance with [Table 9](#) and [10](#)

**Table 9. SnPb eutectic process (from J-STD-020D)**

Package thickness (mm)	Package reflow temperature (°C)	
	Volume (mm <sup>3</sup> )	
	< 350	≥ 350
< 2.5	235	220
≥ 2.5	220	220

**Table 10. Lead-free process (from J-STD-020D)**

Package thickness (mm)	Package reflow temperature (°C)		
	Volume (mm <sup>3</sup> )		
	< 350	350 to 2000	> 2000
< 1.6	260	260	260
1.6 to 2.5	260	250	245
> 2.5	250	245	245

Moisture sensitivity precautions, as indicated on the packing, must be respected at all times.

Studies have shown that small packages reach higher temperatures during reflow soldering, see [Figure 13](#).

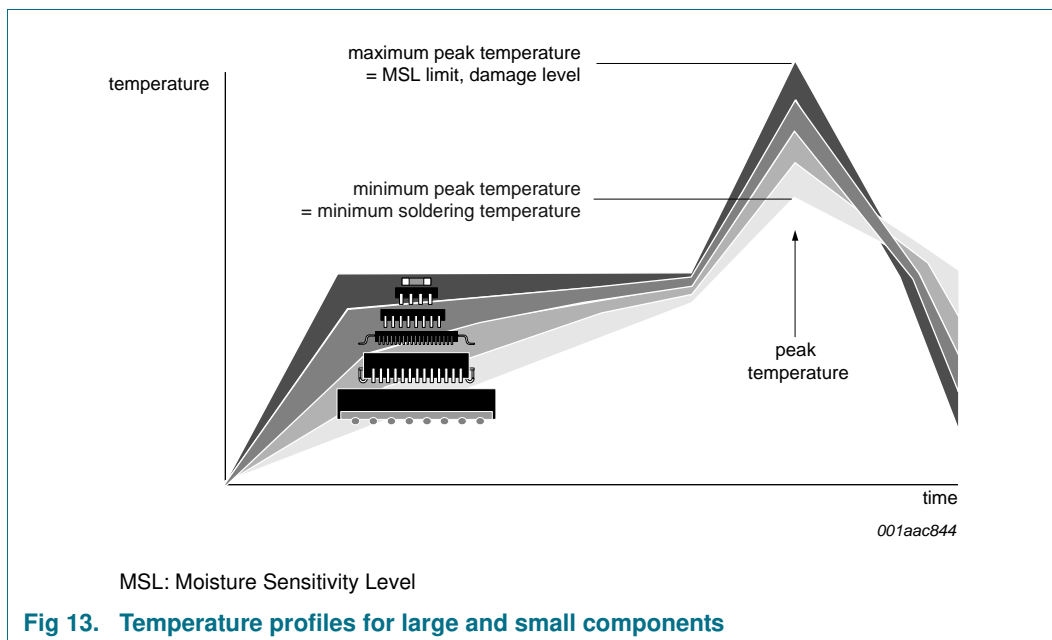

For further information on temperature profiles, refer to Application Note *AN10365* “*Surface mount reflow soldering description*”.

## 17. Soldering of HVSON packages

[Section 16](#) contains a brief introduction to the techniques most commonly used to solder Surface Mounted Devices (SMD). A more detailed discussion on soldering HVSON leadless package ICs can be found in the following application notes:

- *AN10365* “*Surface mount reflow soldering description*”
- *AN10366* “*HVQFN application information*”

## 18. Appendix: ISO 11898-2:2016 parameter cross-reference list

Table 11. ISO 11898-2:2016 to NXP data sheet parameter conversion

ISO 11898-2:2016		NXP data sheet	
Parameter	Notation	Symbol	Parameter
<b>HS-PMA dominant output characteristics</b>			
Single ended voltage on CAN_H	$V_{CAN\_H}$	$V_{O(dom)}$	dominant output voltage
Single ended voltage on CAN_L	$V_{CAN\_L}$		
Differential voltage on normal bus load	$V_{Diff}$	$V_{O(dif)}$	differential output voltage
Differential voltage on effective resistance during arbitration			
Optional: Differential voltage on extended bus load range			
<b>HS-PMA driver symmetry</b>			
Driver symmetry	$V_{SYM}$	$V_{TXsym}$	transmitter voltage symmetry
<b>Maximum HS-PMA driver output current</b>			
Absolute current on CAN_H	$I_{CAN\_H}$	$I_{O(sc)dom}$	dominant short-circuit output current
Absolute current on CAN_L	$I_{CAN\_L}$		
<b>HS-PMA recessive output characteristics, bus biasing active/inactive</b>			
Single ended output voltage on CAN_H	$V_{CAN\_H}$	$V_{O(rec)}$	recessive output voltage
Single ended output voltage on CAN_L	$V_{CAN\_L}$		
Differential output voltage	$V_{Diff}$	$V_{O(dif)}$	differential output voltage
<b>Optional HS-PMA transmit dominant timeout</b>			
Transmit dominant timeout, long	$t_{dom}$	$t_{to(dom)TXD}$	TXD dominant time-out time
Transmit dominant timeout, short			
<b>HS-PMA static receiver input characteristics, bus biasing active/inactive</b>			
Recessive state differential input voltage range	$V_{Diff}$	$V_{th(RX)dif}$	differential receiver threshold voltage
Dominant state differential input voltage range		$V_{rec(RX)}$	receiver recessive voltage
		$V_{dom(RX)}$	receiver dominant voltage
<b>HS-PMA receiver input resistance (matching)</b>			
Differential internal resistance	$R_{Diff}$	$R_{i(dif)}$	differential input resistance
Single ended internal resistance	$R_{CAN\_H}$ $R_{CAN\_L}$	$R_i$	input resistance
Matching of internal resistance	MR	$\Delta R_i$	input resistance deviation
<b>HS-PMA implementation loop delay requirement</b>			
Loop delay	$t_{Loop}$	$t_{d(TXDH-RXDH)}$	delay time from TXD HIGH to RXD HIGH
		$t_{d(TXDL-RXDL)}$	delay time from TXD LOW to RXD LOW
<b>Optional HS-PMA implementation data signal timing requirements for use with bit rates above 1 Mbit/s up to 2 Mbit/s and above 2 Mbit/s up to 5 Mbit/s</b>			
Transmitted recessive bit width @ 2 Mbit/s / @ 5 Mbit/s, intended	$t_{Bit(Bus)}$	$t_{bit(bus)}$	transmitted recessive bit width
Received recessive bit width @ 2 Mbit/s / @ 5 Mbit/s	$t_{Bit(RXD)}$	$t_{bit(RXD)}$	bit time on pin RXD
Receiver timing symmetry @ 2 Mbit/s / @ 5 Mbit/s	$\Delta t_{Rec}$	$\Delta t_{rec}$	receiver timing symmetry

Table 11. ISO 11898-2:2016 to NXP data sheet parameter conversion

ISO 11898-2:2016		NXP data sheet	
Parameter	Notation	Symbol	Parameter
<b>HS-PMA maximum ratings of V<sub>CAN_H</sub>, V<sub>CAN_L</sub> and V<sub>Diff</sub></b>			
Maximum rating V <sub>Diff</sub>	V <sub>Diff</sub>	V <sub>(CANH-CANL)</sub>	voltage between pin CANH and pin CANL
General maximum rating V <sub>CAN_H</sub> and V <sub>CAN_L</sub>	V <sub>CAN_H</sub>	V <sub>x</sub>	voltage on pin x
Optional: Extended maximum rating V <sub>CAN_H</sub> and V <sub>CAN_L</sub>	V <sub>CAN_L</sub>		
<b>HS-PMA maximum leakage currents on CAN_H and CAN_L, unpowered</b>			
Leakage current on CAN_H, CAN_L	I <sub>CAN_H</sub> I <sub>CAN_L</sub>	I <sub>L</sub>	leakage current
<b>HS-PMA bus biasing control timings</b>			
CAN activity filter time, long	t <sub>Filter</sub>	t <sub>wake(busdom)</sub> <sup>[1]</sup>	bus dominant wake-up time
CAN activity filter time, short		t <sub>wake(busrec)</sub> <sup>[1]</sup>	bus recessive wake-up time
Wake-up timeout, short	t <sub>Wake</sub>	t <sub>to(wake)bus</sub>	bus wake-up time-out time
Wake-up timeout, long			
Timeout for bus inactivity	t <sub>Silence</sub>	t <sub>to(silence)</sub>	bus silence time-out time
Bus Bias reaction time	t <sub>Bias</sub>	t <sub>d(busact-bias)</sub>	delay time from bus active to bias

[1] t<sub>fltr(wake)bus</sub> - bus wake-up filter time, in devices with basic wake-up functionality

## 19. Revision history

Table 12. Revision history

Document ID	Release date	Data sheet status	Change notice	Supersedes
TJA1049 v.6	20170115	Product data sheet	-	TJA1049 v.5.01
Modifications:	<ul style="list-style-type: none"> <li>• Updated to comply with ISO 11898-2:2016 and SAE J22884-1 through SAE J2284-5 specifications:               <ul style="list-style-type: none"> <li>– <a href="#">Section 1</a>: text amended (2nd last paragraph)</li> <li>– <a href="#">Section 2.1</a>: text amended (1st entry)</li> <li>– <a href="#">Section 7.1.2</a>: text amended (1st paragraph)</li> <li>– <a href="#">Table 7</a>: values/conditions changed for parameters <math>I_{CC}</math>, <math>V_{TXsym}</math>, <math>V_{rec(RX)}</math>, <math>V_{dom(RX)}</math>, <math>I_{O(sc)dom}</math>; measurement conditions added to parameters <math>R_i</math>, <math>\Delta R_i</math> and <math>R_{i(dif)}</math>;</li> <li>– <a href="#">Table 7</a>: additional measurements taken at <math>f_{TXD} = 1</math> MHz and 2.5 MHz for parameter <math>V_{TXsym}</math>; see <a href="#">Figure 10</a></li> <li>– <a href="#">Table 8</a>: <a href="#">Table note 4</a> added</li> <li>– <a href="#">Figure 6</a>: title changed</li> </ul> </li> <li>• <a href="#">Section 7.2.2</a> added</li> <li>• <a href="#">Table 8</a>: parameter <math>t_{to(dom)bus}</math> added</li> <li>• Amended <a href="#">Figure 5</a>, <a href="#">Figure 7</a>, <a href="#">Figure 8</a> and <a href="#">Figure 10</a></li> </ul>			
TJA1049 v.5.01	20160523	Product data sheet	-	TJA1049 v.4
TJA1049 v.4	20150115	Product data sheet	-	TJA1049 v.3
TJA1049 v3	20130916	Product data sheet	-	TJA1049 v.2
TJA1049 v.2	20110323	Product data sheet	-	TJA1049 v.1
TJA1049 v.1	20100924	Product data sheet	-	-



## 20. Legal information

### 20.1 Data sheet status

Document status <sup>[1][2]</sup>	Product status <sup>[3]</sup>	Definition
Objective [short] data sheet	Development	This document contains data from the objective specification for product development.
Preliminary [short] data sheet	Qualification	This document contains data from the preliminary specification.
Product [short] data sheet	Production	This document contains the product specification.

[1] Please consult the most recently issued document before initiating or completing a design.

[2] The term 'short data sheet' is explained in section "Definitions".

[3] The product status of device(s) described in this document may have changed since this document was published and may differ in case of multiple devices. The latest product status information is available on the Internet at URL <http://www.nxp.com>.

### 20.2 Definitions

**Draft** — The document is a draft version only. The content is still under internal review and subject to formal approval, which may result in modifications or additions. NXP Semiconductors does not give any representations or warranties as to the accuracy or completeness of information included herein and shall have no liability for the consequences of use of such information.

**Short data sheet** — A short data sheet is an extract from a full data sheet with the same product type number(s) and title. A short data sheet is intended for quick reference only and should not be relied upon to contain detailed and full information. For detailed and full information see the relevant full data sheet, which is available on request via the local NXP Semiconductors sales office. In case of any inconsistency or conflict with the short data sheet, the full data sheet shall prevail.

**Product specification** — The information and data provided in a Product data sheet shall define the specification of the product as agreed between NXP Semiconductors and its customer, unless NXP Semiconductors and customer have explicitly agreed otherwise in writing. In no event however, shall an agreement be valid in which the NXP Semiconductors product is deemed to offer functions and qualities beyond those described in the Product data sheet.

### 20.3 Disclaimers

**Limited warranty and liability** — Information in this document is believed to be accurate and reliable. However, NXP Semiconductors does not give any representations or warranties, expressed or implied, as to the accuracy or completeness of such information and shall have no liability for the consequences of use of such information. NXP Semiconductors takes no responsibility for the content in this document if provided by an information source outside of NXP Semiconductors.

In no event shall NXP Semiconductors be liable for any indirect, incidental, punitive, special or consequential damages (including - without limitation - lost profits, lost savings, business interruption, costs related to the removal or replacement of any products or rework charges) whether or not such damages are based on tort (including negligence), warranty, breach of contract or any other legal theory.

Notwithstanding any damages that customer might incur for any reason whatsoever, NXP Semiconductors' aggregate and cumulative liability towards customer for the products described herein shall be limited in accordance with the *Terms and conditions of commercial sale* of NXP Semiconductors.

**Right to make changes** — NXP Semiconductors reserves the right to make changes to information published in this document, including without limitation specifications and product descriptions, at any time and without notice. This document supersedes and replaces all information supplied prior to the publication hereof.

**Suitability for use in automotive applications** — This NXP Semiconductors product has been qualified for use in automotive applications. Unless otherwise agreed in writing, the product is not designed, authorized or warranted to be suitable for use in life support, life-critical or safety-critical systems or equipment, nor in applications where failure or malfunction of an NXP Semiconductors product can reasonably be expected to result in personal injury, death or severe property or environmental damage. NXP Semiconductors and its suppliers accept no liability for inclusion and/or use of NXP Semiconductors products in such equipment or applications and therefore such inclusion and/or use is at the customer's own risk.

**Applications** — Applications that are described herein for any of these products are for illustrative purposes only. NXP Semiconductors makes no representation or warranty that such applications will be suitable for the specified use without further testing or modification.

Customers are responsible for the design and operation of their applications and products using NXP Semiconductors products, and NXP Semiconductors accepts no liability for any assistance with applications or customer product design. It is customer's sole responsibility to determine whether the NXP Semiconductors product is suitable and fit for the customer's applications and products planned, as well as for the planned application and use of customer's third party customer(s). Customers should provide appropriate design and operating safeguards to minimize the risks associated with their applications and products.

NXP Semiconductors does not accept any liability related to any default, damage, costs or problem which is based on any weakness or default in the customer's applications or products, or the application or use by customer's third party customer(s). Customer is responsible for doing all necessary testing for the customer's applications and products using NXP Semiconductors products in order to avoid a default of the applications and the products or of the application or use by customer's third party customer(s). NXP does not accept any liability in this respect.

**Limiting values** — Stress above one or more limiting values (as defined in the Absolute Maximum Ratings System of IEC 60134) will cause permanent damage to the device. Limiting values are stress ratings only and (proper) operation of the device at these or any other conditions above those given in the Recommended operating conditions section (if present) or the Characteristics sections of this document is not warranted. Constant or repeated exposure to limiting values will permanently and irreversibly affect the quality and reliability of the device.

**Terms and conditions of commercial sale** — NXP Semiconductors products are sold subject to the general terms and conditions of commercial sale, as published at <http://www.nxp.com/profile/terms>, unless otherwise agreed in a valid written individual agreement. In case an individual agreement is concluded only the terms and conditions of the respective agreement shall apply. NXP Semiconductors hereby expressly objects to applying the customer's general terms and conditions with regard to the purchase of NXP Semiconductors products by customer.

**No offer to sell or license** — Nothing in this document may be interpreted or construed as an offer to sell products that is open for acceptance or the grant, conveyance or implication of any license under any copyrights, patents or other industrial or intellectual property rights.

**Export control** — This document as well as the item(s) described herein may be subject to export control regulations. Export might require a prior authorization from competent authorities.

**Quick reference data** — The Quick reference data is an extract of the product data given in the Limiting values and Characteristics sections of this document, and as such is not complete, exhaustive or legally binding.

**Translations** — A non-English (translated) version of a document is for reference only. The English version shall prevail in case of any discrepancy between the translated and English versions.

## 20.4 Trademarks

Notice: All referenced brands, product names, service names and trademarks are the property of their respective owners.

## 21. Contact information

---

For more information, please visit: <http://www.nxp.com>

For sales office addresses, please send an email to: [salesaddresses@nxp.com](mailto:salesaddresses@nxp.com)

## 22. Contents

<b>1</b>	<b>General description</b> . . . . .	<b>1</b>	20.1	Data sheet status . . . . .	25
<b>2</b>	<b>Features and benefits</b> . . . . .	<b>1</b>	20.2	Definitions . . . . .	25
2.1	General . . . . .	1	20.3	Disclaimers . . . . .	25
2.2	Low-power management . . . . .	2	20.4	Trademarks . . . . .	26
2.3	Protection . . . . .	2	<b>21</b>	<b>Contact information</b> . . . . .	<b>26</b>
<b>3</b>	<b>Quick reference data</b> . . . . .	<b>2</b>	<b>22</b>	<b>Contents</b> . . . . .	<b>27</b>
<b>4</b>	<b>Ordering information</b> . . . . .	<b>3</b>			
<b>5</b>	<b>Block diagram</b> . . . . .	<b>4</b>			
<b>6</b>	<b>Pinning information</b> . . . . .	<b>5</b>			
6.1	Pinning . . . . .	5			
6.2	Pin description . . . . .	5			
<b>7</b>	<b>Functional description</b> . . . . .	<b>6</b>			
7.1	Operating modes . . . . .	6			
7.1.1	Normal mode . . . . .	6			
7.1.2	Standby mode . . . . .	6			
7.2	Fail-safe features . . . . .	7			
7.2.1	TXD dominant time-out function . . . . .	7			
7.2.2	Internal biasing of TXD and STB input pins . . . . .	7			
7.2.3	Undervoltage detection on pins $V_{CC}$ and $V_{IO}$ . . . . .	7			
7.2.4	Overtemperature protection . . . . .	7			
7.3	SPLIT output pin and $V_{IO}$ supply pin . . . . .	7			
7.3.1	SPLIT pin . . . . .	8			
7.3.2	$V_{IO}$ supply pin . . . . .	8			
<b>8</b>	<b>Limiting values</b> . . . . .	<b>9</b>			
<b>9</b>	<b>Thermal characteristics</b> . . . . .	<b>9</b>			
<b>10</b>	<b>Static characteristics</b> . . . . .	<b>10</b>			
<b>11</b>	<b>Dynamic characteristics</b> . . . . .	<b>12</b>			
<b>12</b>	<b>Application information</b> . . . . .	<b>14</b>			
12.1	Application diagrams . . . . .	14			
12.2	Application hints . . . . .	15			
<b>13</b>	<b>Test information</b> . . . . .	<b>15</b>			
13.1	Quality information . . . . .	16			
<b>14</b>	<b>Package outline</b> . . . . .	<b>17</b>			
<b>15</b>	<b>Handling information</b> . . . . .	<b>19</b>			
<b>16</b>	<b>Soldering of SMD packages</b> . . . . .	<b>19</b>			
16.1	Introduction to soldering . . . . .	19			
16.2	Wave and reflow soldering . . . . .	19			
16.3	Wave soldering . . . . .	19			
16.4	Reflow soldering . . . . .	20			
<b>17</b>	<b>Soldering of HVSON packages</b> . . . . .	<b>21</b>			
<b>18</b>	<b>Appendix: ISO 11898-2:2016 parameter cross-reference list</b> . . . . .	<b>22</b>			
<b>19</b>	<b>Revision history</b> . . . . .	<b>24</b>			
<b>20</b>	<b>Legal information</b> . . . . .	<b>25</b>			

Please be aware that important notices concerning this document and the product(s) described herein, have been included in section 'Legal information'.

© NXP Semiconductors N.V. 2018.

All rights reserved.

For more information, please visit: <http://www.nxp.com>

For sales office addresses, please send an email to: [salesaddresses@nxp.com](mailto:salesaddresses@nxp.com)

Date of release: 15 January 2018

Document identifier: TJA1049