

## 3A Single Cell Switching Battery Charger

### General Description

The RT9470/D device are a highly-integrated 3A switch mode battery charge management and system power path management device for single cell Li-Ion and Li-polymer battery. The low impedance power path optimizes switch-mode operation efficiency, reduces battery charging time and extends battery life during discharging phase. The I<sup>2</sup>C serial interface with charging and system settings makes the device a truly flexible solution.

### Applications

- Smart Phone/Tablet PC
- Personal Information Appliances
- Portable Device and Accessory

### Ordering Information

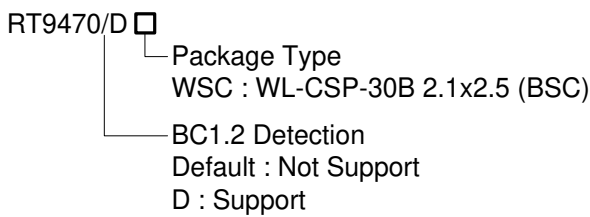

Note :

Richtek products are :

- ▶ RoHS compliant and compatible with the current requirements of IPC/JEDEC J-STD-020.
- ▶ Suitable for use in SnPb or Pb-free soldering processes.

### Features

- **High Efficiency, 1.5MHz, Synchronous Switch-Mode Buck Charger**
  - ▶ **92% Charge Efficiency at 2A from 5V Input and 3.8V Battery**
  - ▶ **Support 3.9V to 13.5V Input Voltage Range**
  - ▶ **Average Input Current Regulation (AICR)**
  - ▶ **Minimum Input Voltage Regulation (MIVR)**
  - ▶ **Minimum Input Voltage Regulation Track (MIVR Track)**
  - ▶ **Charge Current Regulation (CCR)**
  - ▶ **Charge Voltage Regulation (CVR)**
  - ▶ **Charge Voltage Regulation Track (CVR Track)**
  - ▶ **Junction Thermal Regulation (JTR)**
- **Supports USB On-The-Go (OTG)**
  - ▶ **92% Boost Efficiency at 1A with 3.8V Battery and 5.15V Output**
  - ▶ **OTG Current Limit Regulation (OCLR)**
  - ▶ **OTG Voltage Limit Regulation (OVLRL)**
- **Protection**
  - ▶ **Over-Temperature Protection (OTP)**
  - ▶ **VBUS Over-Voltage Protection (VBUS OVP)**
  - ▶ **Battery Over-Voltage Protection (VBAT OVP)**
  - ▶ **System Over-Voltage Protection (VSYS OVP)**
  - ▶ **System Under-Voltage Protection (VSYS UVP)**
  - ▶ **System Over-Load Protection (VSYS OLP)**
  - ▶ **Cycle-by-Cycle Over-Current Protection (OCP)**
  - ▶ **OTG Low Battery Protection (OTG LBP)**

### Simplified Application Circuit

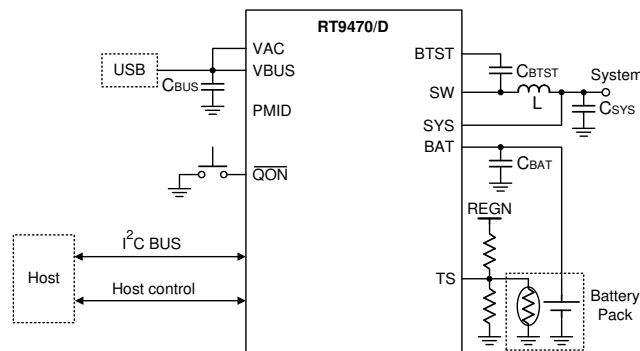

## Marking Information

RT9470WSC

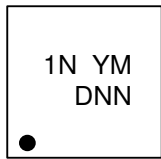

1N : Product Code  
YMDNN : Date Code

RT9470DWSC

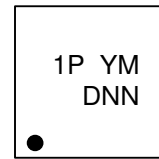

1P : Product Code  
YMDNN : Date Code

## Pin Configuration

(TOP VIEW)

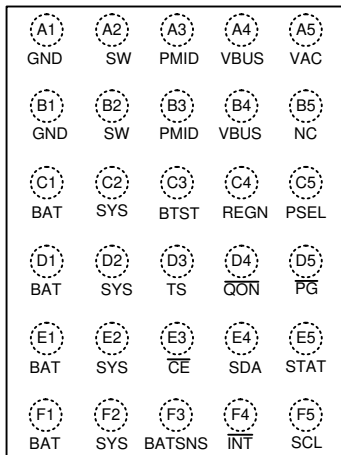

WL-CSP-30B 2.1x2.5 (BSC) (RT9470)

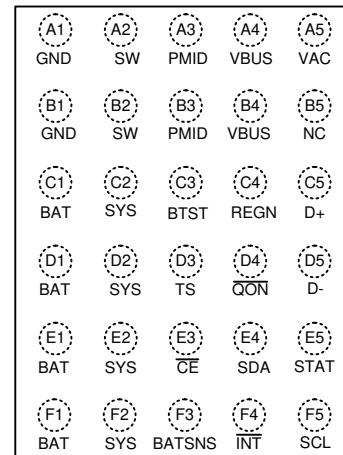

WL-CSP-30B 2.1x2.5 (BSC) (RT9470D)

## Functional Pin Description

Pin No.		Pin Name	I/O	Pin Function
RT9470	RT9470D			
A1, B1	A1, B1	GND	P	Power ground.
A2, B2	A2, B2	SW	P	Switching node connecting to output inductor. Internally SW is connected to the source of the high-side switching MOSFET (Q2) and the drain of the low-side switching MOSFET (Q3). Connect a 47nF bootstrap capacitor from SW to BTST.
A3, B3	A3, B3	PMID	P	Connected to the drain of the reverse blocking MOSFET (Q1) and the drain of high-side switching MOSFET (Q2). Connect 10μF capacitor from PMID to GND.
A4, B4	A4, B4	VBUS	P	Charger input voltage. The internal reverse block MOSFET (Q1) is connected between VBUS and PMID with VBUS on source. Connect a 1μF capacitor from VBUS to GND and place it as close as possible to IC.
A5	A5	VAC	AI	Input voltage sensing. This pin must be tied to VBUS.
B5	B5	NC	--	No internal connection.

Pin No.		Pin Name	I/O	Pin Function
RT9470	RT9470D			
C1, D1, E1, F1	C1, D1, E1, F1	BAT	P	Battery connection point to the positive terminal of the battery pack. The internal current sensing resistor is connected between SYS and BAT. Connect a 10 $\mu$ F capacitor closely to the BAT pin.
C2, D2, E2, F2	C2, D2, E2, F2	SYS	P	Converter output connection point. The internal current sensing resistor is connected between SYS and BAT. Connect two 10 $\mu$ F capacitors closely to the SYS pin.
C3	C3	BTST	P	PWM high-side driver positive supply. Internally, the BTST is connected to the cathode of the boost-strap diode. Connect the 47nF bootstrap capacitor from SW to BTST.
C4	C4	REGN	P	PWM low-side driver and internal supply output. Internally, REGN is connected to the anode of the bootstrap diode. Connect a 4.7 $\mu$ F capacitor from REGN to GND. The capacitor should be placed close to the IC.
C5	--	PSEL	DI	Power source selection input. High indicates 0.5A input current limit. Low indicates 2.4A input current limit. Once the device gets into host mode, the host can program different input current limit to AICR register.
--	C5	D+	AIO	Positive line of the USB data line pair. D+/D– based USB host/charging port detection. The detection includes data contact detection (DCD), primary and secondary detections in BC1.2.
D3	D3	TS	AI	Temperature qualification voltage input to support JEITA profile. Connect a negative temperature coefficient thermistor. Program temperature window with a resistor divider from REGN to TS to GND. Charge suspends when TS pin voltage is out of range. When TS pin is not used, connect a 10k $\Omega$ resistor from REGN to TS and a 10k $\Omega$ resistor from TS to GND.
D4	D4	$\overline{\text{QON}}$	DI	BATFET (Q4) enable control input. When BATFET is in ship mode, a logic low duration turns on BATFET (Q4) to exit shipping mode. When no VBUS, a logic low for tQON_RST, the BATFET turns off for tBATFET_RST, and then re-enable BATFET to provide system reset. Pull-High to internal bias circuit via 250k $\Omega$ resistor.
D5	--	$\overline{\text{PG}}$	DO	Open-drain active low power good indicator. Connect the $\overline{\text{PG}}$ pin to a logic rail via 2.2k $\Omega$ to 10k $\Omega$ resistor.
--	D5	D-	AIO	Negative line of the USB data line pair. D+/D– based USB host/charging port detection. The detection includes data contact detection (DCD), primary and secondary detections in BC1.2.
E3	E3	$\overline{\text{CE}}$	DI	Charge enable pin. When this pin is driven low, battery charging is enabled.
E4	E4	SDA	DIO	I <sup>2</sup> C interface clock. Connect SDA to the logic rail through a 10k $\Omega$ resistor.
E5	E5	STAT	DO	Open-drain charger status output. Connect the STAT pin to a logic rail via 2.2k $\Omega$ to 10k $\Omega$ resistor. The STAT pin indicates charger status.

Pin No.		Pin Name	I/O	Pin Function
RT9470	RT9470D			
F3	F3	BATSNS	AI	Battery voltage sensing pin for charge current regulation. The BATNS pin must be connected to the battery pack as close as possible.
F4	F4	$\overline{\text{INT}}$	DO	Open-drain active low interrupt output. Connect the $\overline{\text{INT}}$ to a logic rail through 10k $\Omega$ resistor. The INT pin sends active low pulse to host to report charger device status and fault.
F5	F5	SCL	DI	I <sup>2</sup> C interface clock. Connect SCL to the logic rail through a 10k $\Omega$ resistor.

## Functional Block Diagram

RT9470 Functional Block Diagram

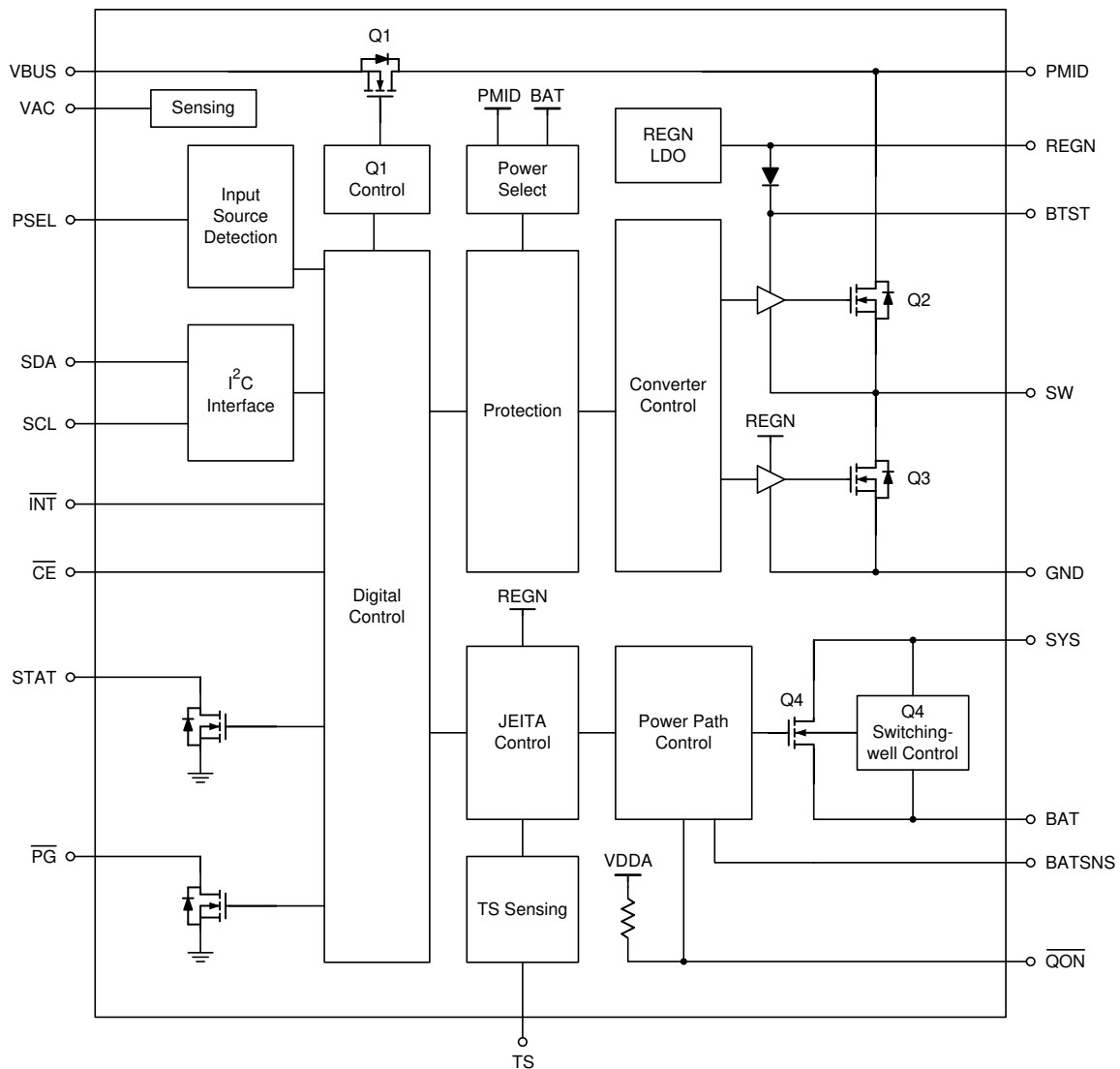

**RT9470D Functional Block Diagram**

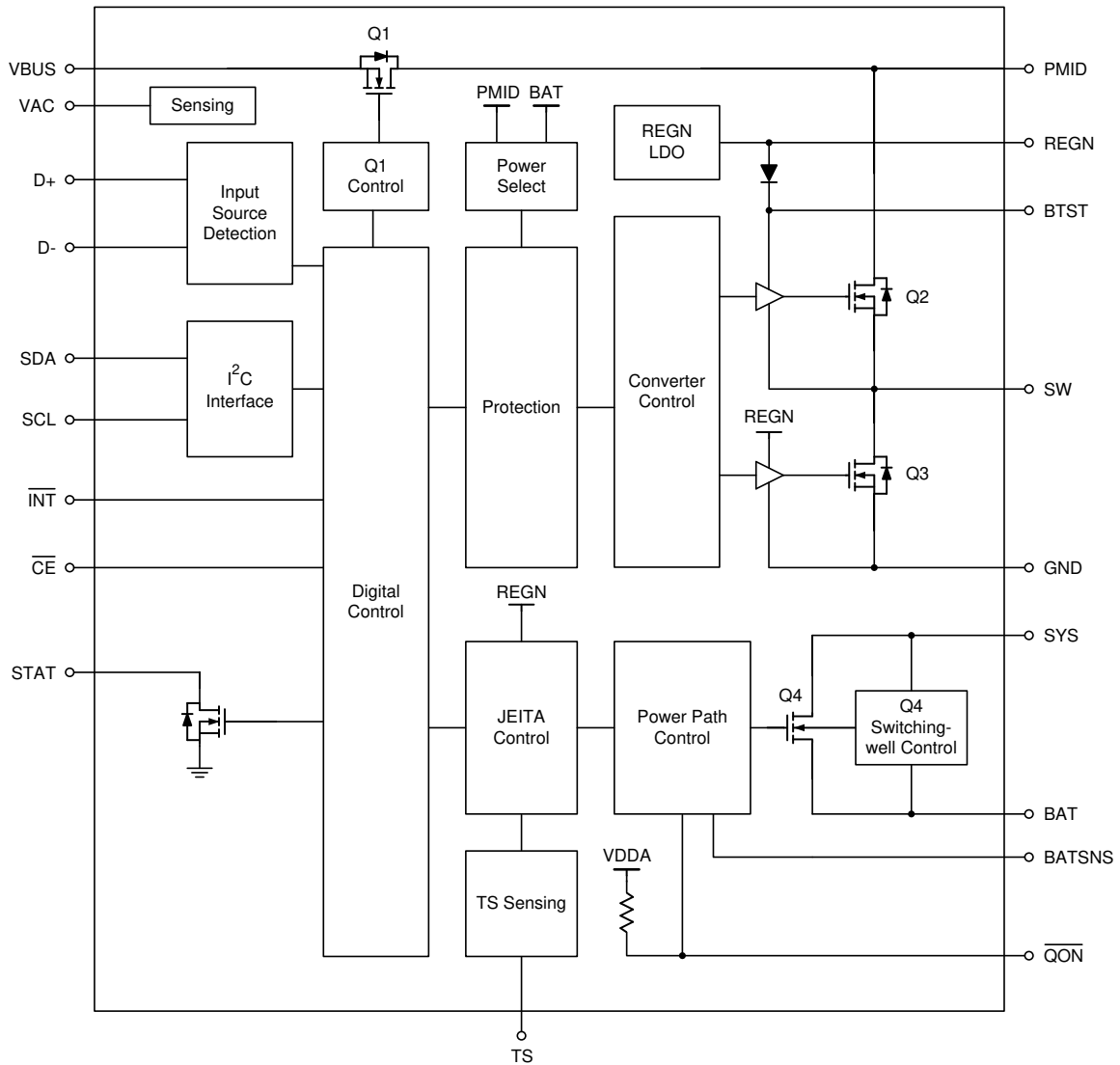

## Absolute Maximum Ratings (Note 1)

• Voltage Sense Pin Voltage, VAC	-----	-1.4V to 22V
• Supply Pin Voltage, VBUS	-----	-1.4V to 22V
• Terminal Pin Voltage, PMID	-----	-0.3V to 22V
• Terminal Pin Voltage, SW	-----	-0.3V to 16V
• Terminal Pin Voltage, BTST-SW	-----	-0.3V to 6V
• Terminal Pin Voltage, SYS	-----	-0.3V to 6V
• Supply Pin Voltage, BAT	-----	-0.3V to 6V
• Voltage Sense Pin Voltage, BATSNS	-----	-0.3V to 6V
• Other Pins Voltage, STAT, SCL, SDA, $\overline{\text{INT}}$ , $\overline{\text{CE}}$ , TS, $\overline{\text{QON}}$ , REGN	-----	-0.3V to 6V
• Other Pins Voltage for RT9470, PSEL, $\overline{\text{PG}}$	-----	-0.3V to 6V
• Other Pins Voltage for RT9470D, D+, D-	-----	-0.3V to 6V
• Power Dissipation, Pd @ TA = 25°C		
WL-CSP-30B 2.1x2.5 (BSC)	-----	4.22W
• Package Thermal Resistance (Note 2)		
WL-CSP-30B 2.1x2.5 (BSC), $\theta_{JA}$	-----	29.6°C/W
• Lead Temperature (Soldering, 10 sec.)	-----	260°C
• Junction Temperature	-----	150°C
• Storage Temperature Range	-----	-65°C to 150°C
• ESD Susceptibility (Note 3)		
HBM (Human Body Model)	-----	2kV

## Recommended Operating Conditions (Note 4)

• Voltage Sense Pin Voltage, VAC	-----	3.9V to 13.5V
• Supply Input Voltage Range, VBUS	-----	3.9V to 13.5V
• Maximum Input Current, IBUS	-----	3.2A
• Maximum Input Current, IBUS (VBUS ≥ 12V)	-----	2A
• Maximum Output Current (SW), ISYS	-----	3.2A
• Maximum Battery Voltage, VBAT	-----	4.7V
• Voltage Sense Pin Voltage, BATSNS	-----	4.7V
• Maximum Charge Current, IBAT	-----	3.15A
• Maximum Discharge Current, IBAT	-----	6A
• Ambient Temperature Range	-----	-40°C to 85°C
• Junction Temperature Range	-----	-40°C to 150°C

**Electrical Characteristics**

( $V_{BUS\_MIN\_RISE} < V_{AC} < V_{AC\_OVP\_RISE}$  and  $V_{AC} > V_{BAT} + V_{SLEEP\_RISE}$ ,  $T_A = 25^\circ\text{C}$ , unless otherwise specified) (Note 5)

Parameter	Symbol	Test Conditions	Min	Typ	Max	Unit
<b>Quiescent Current</b>						
Battery Discharge Current (BAT) in Q4 Disabled	IBAT_Q4_DIS	$V_{BAT} = 4.5\text{V}$ , High-Z mode and I <sup>2</sup> C disabled, Q4 disabled	--	15	32	μA
Battery Discharge Current (BAT) in Q4 Enable	IBAT_Q4_EN	$V_{BAT} = 4.5\text{V}$ , High-Z mode and I <sup>2</sup> C disabled, Q4 enabled	--	55	85	μA
Input Supply Current (VBUS) in Buck Mode	IBUS_HIZ	$V_{BUS} = 5\text{V}$ , High-Z mode and no battery	--	50	86	μA
		$V_{BUS} = 12\text{V}$ , High-Z mode and no battery	--	52	88	
Input Supply Current (VBUS) in Buck Mode	IBUS_BUCK	$V_{BUS} > V_{BUS\_MIN\_RISE}$ , $V_{BUS} > V_{BAT}$ , converter switching, $V_{BAT} = 3.8\text{V}$ , $I_{SYS} = 0\text{A}$	--	5	7	mA
Battery Discharge Current (BAT) in Boost Mode	IBAT_BOOST	$V_{BAT} = 4.2\text{V}$ , boost mode, $I_{BUS} = 0\text{A}$ , converter switching	--	4	5	mA
<b>VAC, VBUS and BAT Power</b>						
VBUS Operating Range	VBUS_OP	VBUS rising	3.9	--	13.5	V
REGN Turn Off Level with Only VBUS	VBUS_UVLO	VBUS falling	3.0	3.3	3.6	V
Sleep Mode Falling Threshold	VSLEEP_FALL	$V_{AC}$ falling, $V_{AC} - V_{BAT}$	10	60	120	mV
Sleep Mode Rising Threshold	VSLEEP_RISE	$V_{AC}$ rising, $V_{AC} - V_{BAT}$	160	250	340	mV
VAC 5.8V Over-Voltage rising threshold	VAC_OVP_RISE	$V_{AC}$ rising	5.5	5.8	6.1	V
VAC 6.5V Over-Voltage rising threshold		$V_{AC}$ rising	6.2	6.5	6.8	
VAC 10.9V Over-Voltage Rising Threshold		$V_{AC}$ rising	10.3	10.9	11.5	
VAC 14V Over-Voltage Rising Threshold		$V_{AC}$ rising	13.3	14	14.7	
VAC 5.8V Over-Voltage Hysteresis	VAC_OVP_HYS	$V_{AC}$ falling	--	300	--	mV
VAC 6.5V Over-Voltage Hysteresis		$V_{AC}$ falling	--	300	--	
VAC 10.9V Over-Voltage Hysteresis		$V_{AC}$ falling	--	300	--	
VAC 14V Over-Voltage Hysteresis		$V_{AC}$ falling	--	300	--	
BAT for Active I <sup>2</sup> C, No Adapter	VBAT_UVLO	VBAT rising	2	2.2	2.4	V

Parameter	Symbol	Test Conditions	Min	Typ	Max	Unit
Battery Depletion Falling Threshold	VBAT_DPL_FALL	VBAT falling	2.15	2.38	2.65	V
Battery Depletion Rising Threshold	VBAT_DPL_RISE	VBAT rising	2.4	2.6	2.8	V
Battery Depletion Rising Hysteresis	VBAT_DPL_HYS	VBAT rising	--	220	--	mV
Bad Adapter Detection Rising Threshold	VBUS_MIN_RISE	VBUS rising	3.6	3.8	4	V
Bad Adapter Detection Hysteresis	VBUS_MIN_HYS	VBUS falling	--	200	--	mV
Bad Adapter Detection Current Source	IBADSRC	Sink current from VBUS to GND	--	40	--	mA
<b>Power Path</b>						
System Regulation Voltage	V <sub>SYN</sub> _MIN	V <sub>BAT</sub> < V <sub>SYN</sub> _MIN = 3.5V, Q4 disabled/enable	3.5	3.5 +0.2	--	V
	V <sub>SYN</sub>	I <sub>SYN</sub> = 0A, V <sub>BAT</sub> > V <sub>SYN</sub> _MIN = 3.5V, Q4 disabled	--	V <sub>BAT</sub> +0.05	--	
Top Reverse Blocking MOSFET On-Resistance Between VBUS and PMID	R <sub>ON</sub> (Q1)	-40°C ≤ T <sub>A</sub> ≤ 125°C	--	29	--	mΩ
Top Switching MOSFET On-Resistance Between PMID and SW	R <sub>ON</sub> (Q2)	V <sub>REGN</sub> = 5V, -40°C ≤ T <sub>A</sub> ≤ 125°C	--	46	--	mΩ
Bottom Switching MOSFET On-Resistance Between SW and GND	R <sub>ON</sub> (Q3)	V <sub>REGN</sub> = 5V, -40°C ≤ T <sub>A</sub> ≤ 125°C	--	51	--	mΩ
SYS-BAT MOSFET On-Resistance	R <sub>ON</sub> (BAT-SYS)	Measured from BAT to SYS, V <sub>BAT</sub> = 4.2V, T <sub>J</sub> = 25°C	--	14	--	mΩ
<b>Battery Charger</b>						
Charge Voltage Range	VBAT_REG_RANGE	Default = 4.2V	3.9	--	4.7	V
Charge Voltage Step	VBAT_REG_STEP		--	10	--	mV
Charge Voltage Setting Accuracy	VBAT_REG_ACC		-0.5	--	0.5	%
Charge Current Regulation Range	ICHG_REG_RANGE	Default = 2000mA	0	--	3150	mA
Charge Current Regulation Step	ICHG_REG_STEP		--	50	--	mA
Charge Current Regulation Accuracy	ICHG_REG_ACC	V <sub>BAT</sub> = 3.8V, I <sub>CHG_REG</sub> < 150mA	-20	--	20	%
		V <sub>BAT</sub> = 3.8V, 150mA ≤ I <sub>CHG_REG</sub> < 750mA	-10	--	10	
		V <sub>BAT</sub> = 3.8V, I <sub>CHG_REG</sub> ≥ 750mA	-5	--	5	
Pre-Charge Falling Threshold	V <sub>PRE_CHG_FALL</sub>	I <sub>CHG</sub> = 200mA, V <sub>PRE_CHG</sub> = 3.1V	2.75	2.9	3.05	V
Pre-Charge Rising Threshold	V <sub>PRE_CHG_RISE</sub>	Pre-charge to fast charge, V <sub>PRE_CHG</sub> = 3.1V	2.95	3.1	3.25	V



Parameter	Symbol	Test Conditions	Min	Typ	Max	Unit
Pre-Charge Current Range	IPRE_CHG_RANGE	Default = 150mA	50	--	800	mA
Pre-Charge Current Step	IPRE_CHG_STEP		--	50	--	mA
Pre-Charge Accuracy	IPRE_CHG_ACC	V <sub>BUS</sub> = 5V, I <sub>PRE_CHG</sub> = 150mA	-15	--	25	%
End-Of-Charge Current Range	IEOC_CHG_RANGE	Default = 200mA	50	--	800	mA
End-Of-Charge Current Step	IEOC_CHG_STEP		--	50	--	mA
End-Of-Charge Accuracy	IEOC_CHG_ACC	I <sub>CHG_REG</sub> > 700mA, I <sub>EOC_CHG</sub> = 200mA, V <sub>BAT</sub> = 4.2V	-20	--	20	%
		I <sub>CHG_REG</sub> ≤ 700mA, I <sub>EOC_CHG</sub> = 200mA, V <sub>BAT</sub> = 4.2V	-10	--	10	
		I <sub>CHG_REG</sub> = 600mA, I <sub>EOC_CHG</sub> = 50mA, V <sub>BAT</sub> = 4.2V	-25	--	25	
Trickle-Charge Falling Threshold	V <sub>TRICKLE_CHG_FALL</sub>	V <sub>BAT</sub> falling	1.8	2	2.2	V
Trickle-Charge Rising Threshold	V <sub>TRICKLE_CHG_RISE</sub>	V <sub>BAT</sub> rising	2.05	2.25	2.45	V
Trickle-Charge Current	I <sub>TRICKLE_CHG</sub>	V <sub>BAT</sub> < V <sub>TRICKLE_CHG_RISE</sub>	80	100	120	mA
Re-Charge Threshold Below V <sub>BAT_REG</sub>	V <sub>RE_CHG</sub>	V <sub>BAT</sub> falling, V <sub>RECHG</sub> = 100mV	70	100	130	mV
		V <sub>BAT</sub> falling, V <sub>RECHG</sub> = 200mV	170	200	230	
System Discharge Load Current	I <sub>SYS_LOAD</sub>	V <sub>SYS</sub> = 4.2V	--	30	--	mA
<b>Input Voltage and Current Regulation</b>						
Minimum Input Voltage Regulation Range	V <sub>MIVR_RANGE</sub>	Default = 4.5V	3.9	--	5.4	V
Minimum Input Voltage Regulation Step	V <sub>MIVR_STEP</sub>		--	100	--	mV
Minimum Input Voltage Regulation Accuracy	V <sub>MIVR_ACC</sub>	V <sub>MIVR</sub> = 3.9V and 4.4V	-1.5	--	1.5	%
MIVR Tracking V <sub>BAT</sub>	V <sub>MIVR_BAT_TRACK</sub>	V <sub>MIVR</sub> = 3.9V, V <sub>MIVR_BAT_TRACK</sub> = 300mV, V <sub>BAT</sub> = 4V	--	4.3	--	V
MIVR Tracking V <sub>BAT</sub> Accuracy	V <sub>MIVR_BAT_TRACK_ACC</sub>		-3	--	3	%
Average Input Current Regulation Range	I <sub>AICR_RANGE</sub>	Default = 0.5A	0.05	--	3.2	A
Average Input Current Regulation Step	I <sub>AICR_STEP</sub>		--	50	--	mA
Average Input Current Regulation Accuracy	I <sub>AICR_ACC</sub>	V <sub>BUS</sub> = 5V, I <sub>AICR</sub> = 500mA	450	470	500	mA
		V <sub>BUS</sub> = 5V, I <sub>AICR</sub> = 900mA	780	840	900	
		V <sub>BUS</sub> = 5V, I <sub>AICR</sub> = 1500mA	1300	1400	1500	
		V <sub>BUS</sub> = 5V, I <sub>AICR</sub> > 1500mA	-15	--	0	%
<b>BAT Over-Voltage Protection</b>						

Parameter	Symbol	Test Conditions	Min	Typ	Max	Unit
Battery Over-Voltage Rising	VBAT_OVP_RISE	VBAT rising, as percentage of VBAT_REG	103	104	105	%
Battery Over-Voltage Falling	VBAT_OVP_FALL	VBAT falling, as percentage of VBAT_REG	101	102	103	%
<b>Input Reverse Blocking NFET and Regulation</b>						
Junction Thermal Regulation Range	TJ_THREG_RANGE	Default = 120°C	100	--	120	°C
Junction Thermal Regulation Step	TJ_THREG_STEP		--	20	--	°C
Thermal Shutdown Rising	TOTP	Temperature rising	--	160	--	°C
Thermal Shutdown Hysteresis	TOTP_HYS	Temperature falling	--	30	--	°C
<b>NTC Monitor (Charger Mode)</b>						
Battery Temperature COLD Threshold (0°C)	VVTS_COLD	VTS rising, the ratio of VREGN	72.5	73.5	74.5	%
Battery Temperature COOL Threshold (10°C)	VVTS_COOL	VTS rising, the ratio of VREGN	67.5	68.5	69.5	%
Battery Temperature WARM Threshold (45°C)	VVTS_WARM	VTS falling, the ratio of VREGN	44	45	46	%
Battery Temperature HOT Threshold (60°C)	VVTS_HOT	VTS falling, the ratio of VREGN	33.5	34.5	35.5	%
Battery Temperature Hysteresis	VVTS_HYS		--	1.5	--	%
<b>NTC Monitor (OTG Mode)</b>						
Battery Temperature COLD Threshold OTG mode (-20°C)	VVTS_COLD_OTG	VTS rising, the ratio of VREGN	79	80	81	%
Battery Temperature HOT Threshold OTG mode (60°C)	VVTS_HOT_OTG	VTS falling, the ratio of VREGN	33.5	34.5	35.5	%
Battery Temperature Hysteresis OTG mode	VVTS_HYS_OTG		--	1.5	--	%
<b>Charger Over-Current Threshold</b>						
UGFET Cycle-by-Cycle Over-Current Threshold	IOCP_UG		5.5	6.5	7.5	A
System Over-Load Threshold	IOCP_BATFET		6	--	--	A
<b>USB On-The-Go (OTG)</b>						
OTG Low Battery Protection	VOTG_LBP	VBAT falling, VOTG_LBP = 2.8V	2.65	2.8	2.95	V
		VBAT rising, VOTG_LBP = 2.8V	2.75	2.9	3.05	
		VBAT falling, VOTG_LBP = 2.5V	2.35	2.5	2.65	
		VBAT rising, VOTG_LBP = 2.5V	2.45	2.6	2.75	

Parameter	Symbol	Test Conditions	Min	Typ	Max	Unit
OTG Voltage Limit Regulation Range	VOTG_CV_RANGE	Default = 5.15V	4.85	--	5.3	V
OTG Voltage Limit Regulation Step	VOTG_CV_STEP		--	150	--	mV
OTG Voltage Limit Regulation Accuracy	VOTG_CV_ACC	V <sub>BAT</sub> = 3.8V, I <sub>PMID</sub> = 0A, V <sub>OTG_REG</sub> = 5.15V	-3	--	3	%
OTG Current Limit Regulation Accuracy	I <sub>OTG_CC</sub>	I <sub>OTG_LIMIT_REG_SEL</sub> = 1.2A	1.2	1.4	1.6	A
		I <sub>OTG_LIMIT_REG_SEL</sub> = 0.5A	0.5	0.6	0.7	
OTG Over-Voltage Threshold	V <sub>OTG_OVP</sub>	V <sub>AC</sub> rising, V <sub>AC_OVP</sub> = 6.5V	6.2	6.5	6.8	V
OTG Capacitive Load	C <sub>OTG_LOAD</sub>	V <sub>BAT</sub> = 3.8V, V <sub>OTG_REG</sub> = 5.15V, capacitive load plug in	--	--	300	μF
<b>PWM</b>						
PWM Switching Frequency	f <sub>SW_BUCK</sub>	Oscillator frequency, buck mode	1350	1500	1650	kHz
	f <sub>SW_BOOST</sub>	Oscillator frequency, boost mode	1350	1500	1650	
Maximum PWM Duty Cycle	D <sub>MAX</sub>		--	97	--	%
<b>REGN</b>						
REGN LDO Output Voltage	V <sub>REGN</sub>	V <sub>BUS</sub> = 9V, I <sub>REGN</sub> = 40mA	4.5	4.9	5.3	V
		V <sub>BUS</sub> = 5V, I <sub>REGN</sub> = 20mA	4.5	4.9	5	
<b>Control I/O Pin (<math>\overline{CE}</math>, PSEL, SCL and SDA)</b>						
Input High Threshold Voltage	V <sub>IH_CTRL</sub>		1.3	--	--	V
Input Low Threshold Voltage	V <sub>IL_CTRL</sub>		--	--	0.4	V
High Level Leakage Current	I <sub>BIAS</sub>	Pull high to 1.8V	--	--	1	μA
<b>Control I/O Pin (<math>\overline{PG}</math>, STAT and <math>\overline{INT}</math>)</b>						
Output Low Threshold Voltage	V <sub>OL_CTRL</sub>		--	--	0.4	V
$\overline{INT}$ Pull Low Time	t <sub>INT_PULL_LOW</sub>	$\overline{INT}$ pull low time	--	256	--	μs
<b>D+/D- Detection</b>						
Data Detect Voltage	V <sub>DAT_REF</sub>		0.25	0.325	0.4	V
D- Current Sink	I <sub>D-_ISNK</sub>		50	100	150	μA
D+D- Leakage Current	I <sub>D+D-_LKG</sub>		-1	--	1	μA
D- Pull Down for Connection Check	R <sub>D-_19K</sub>		14.25	19.53	24.8	kΩ
D+D- Threshold for Non-Standard Adapter (1.2V)	V <sub>D+D-_1P2</sub>		--	1.2	--	V
D+D- Threshold for Non-Standard Adapter (2V)	V <sub>D+D-_2P0</sub>		--	2	--	V

Parameter	Symbol	Test Conditions	Min	Typ	Max	Unit
D+D- Threshold for Non-Standard Adapter (2.8V)	V <sub>D+D-_2P8</sub>		--	2.8	--	V
<b>Timing Requirements</b>						
VAC OVP Reaction Time	t <sub>VAC_OVP</sub>		--	200	--	ns
Bad Adapter Detection Duration	t <sub>BAD_AD_DETECTION</sub>		--	30	--	ms
Deglitch Time for Charger EOC	t <sub>EOC_DGL</sub>		--	256	--	ms
Deglitch Time for Re-Charge	t <sub>RE_CHG_DGL</sub>		--	256	--	ms
Charge Safe Timer	t <sub>CHG_SAFE_TMR</sub>	Timer = 10hr	9	10	11	hr
Back-Ground Charge Timer	t <sub>BG_CHG_TMR</sub>	Timer = 30min	29	30	31	min
<b>QON Timing</b>						
QON Low Time to Exit Shipping Mode	t <sub>SHIPMODE_EXIT</sub>		0.9	1.1	1.3	s
QON Low Time to Reset System	t <sub>QON_RST</sub>		9	10	11	s
BATFET Reset Time	t <sub>BATFET_RST</sub>		430	453	480	ms
Enter Shipping Mode Delay Time	t <sub>SHIP_MODE_ENTER</sub>		11	12	13	s
<b>I<sup>2</sup>C Clock and Watchdog Timer</b>						
SCL Clock	f <sub>SCL</sub>	CB ≤ 100pF	--	--	3.4	MHz
		100pF < CB ≤ 400pF	--	--	1.7	
Watchdog Timer	t <sub>WDT</sub>	Default = 40s	--	40	--	s
Watchdog Reset Wait Time	t <sub>WDT_WAIT</sub>		--	500	--	ms

**Note 1.** Stresses beyond those listed under “Absolute Maximum Ratings” may cause permanent damage to the device. These are stress ratings only, and functional operation of the device at these or any other conditions beyond those indicated in the operational sections of the specifications is not implied. Exposure to absolute maximum rating conditions may affect device reliability.

**Note 2.**  $\theta_{JA}$  is measured under natural convection (still air) at  $T_A = 25^\circ\text{C}$  with the component mounted on a high effective-thermal-conductivity four-layer test board on a JEDEC 51-7 thermal measurement standard.

**Note 3.** Devices are ESD sensitive. Handling precaution is recommended.

**Note 4.** The device is not guaranteed to function outside its operating conditions.

**Note 5.** Specification is guaranteed by design and/or correlation with statistical process control.

**Typical Application Circuit**

**RT9470**

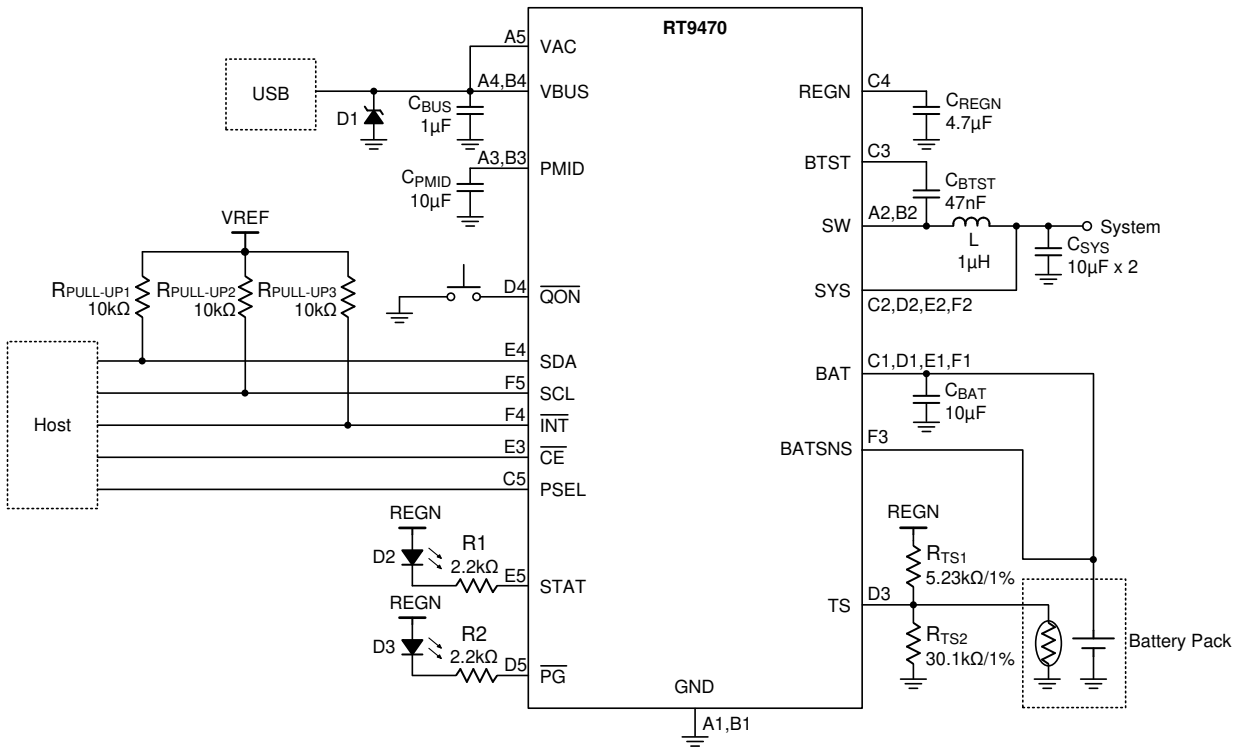

**RT9470D**

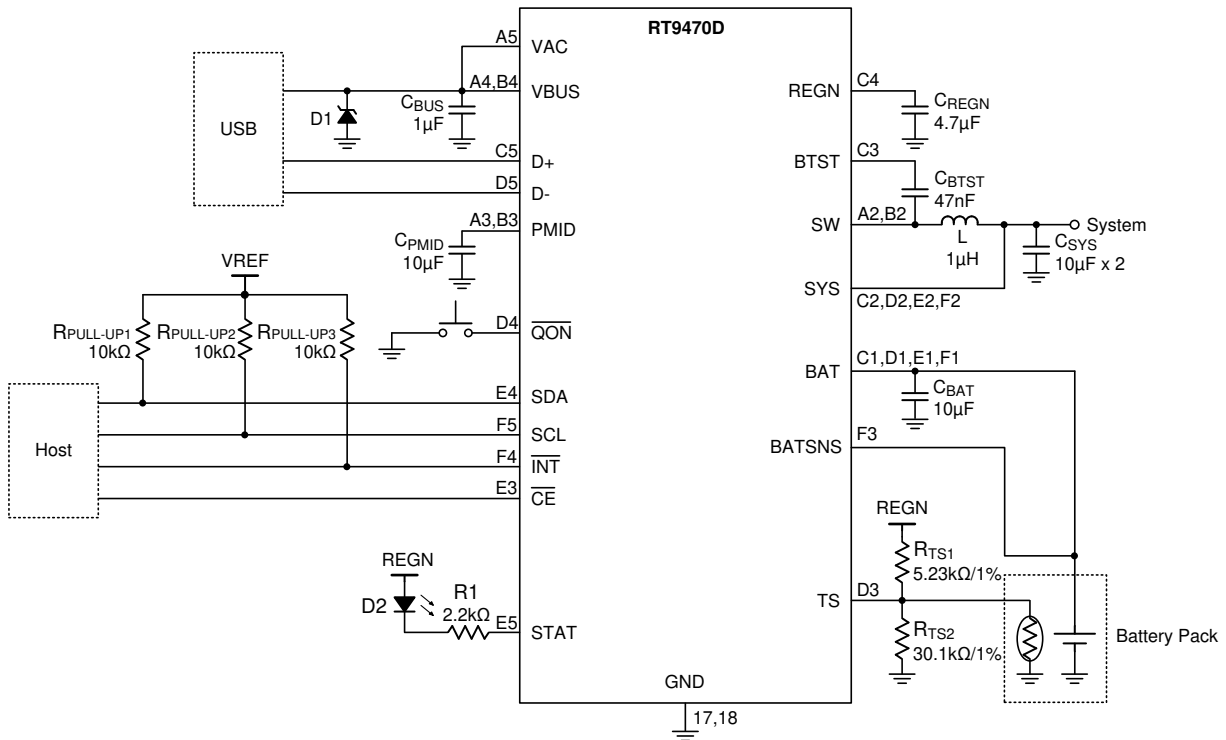

## Below are recommended components information

Name	Description	Part Number	Package	Manufacturer
CBUS	1 $\mu$ F/25V/X5R	GRM155R61E105KA12	0402	muRata
CPMID	10 $\mu$ F/25V/X5R	GRM188R61E106MA73	0603	muRata
CBTST	47nF/16V/X5R	GRM033R61C473KE84	0201	muRata
CSYS	10 $\mu$ F/6.3V/X5R	GRM185R60J106ME15	0603	muRata
CBAT	10 $\mu$ F/6.3V/X5R	GRM185R60J106ME15	0603	muRata
CREGN	4.7 $\mu$ F/6.3V/X5R	GRM155R60J475ME47	0402	muRata
L	1 $\mu$ H/20%	CIGT252010EH1R0MNE	2.5 x 2.0 x 1.0mm	Samsung
D1	PTVSHC3N12VU	TVS Diode	DFN2x2-3L	Prisemi

**Typical Operating Characteristics**

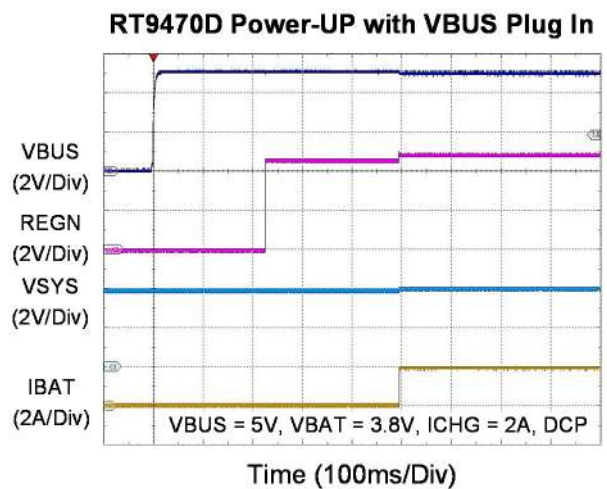
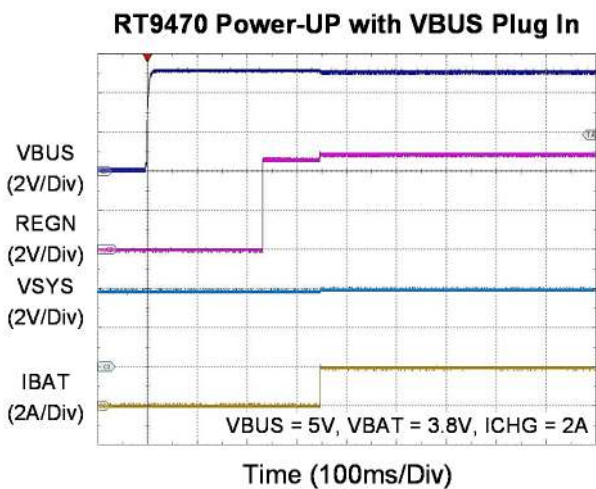
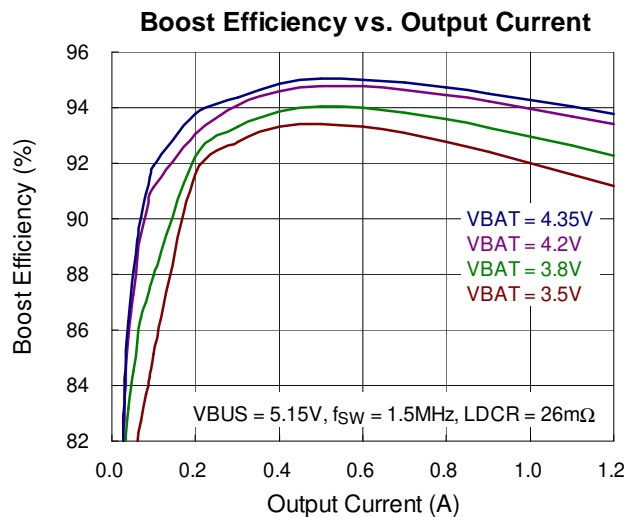
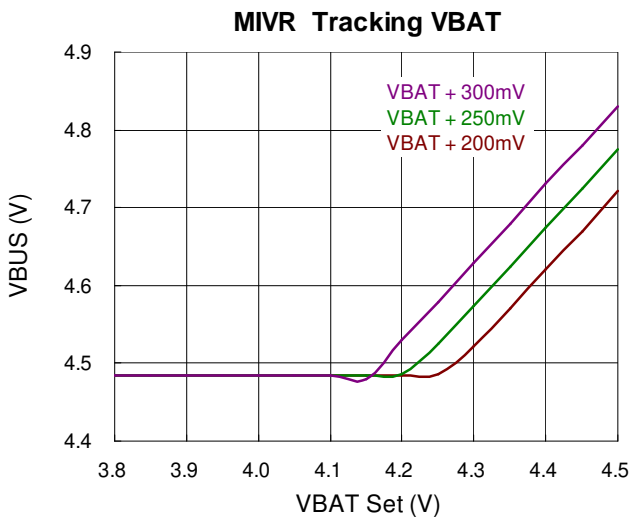
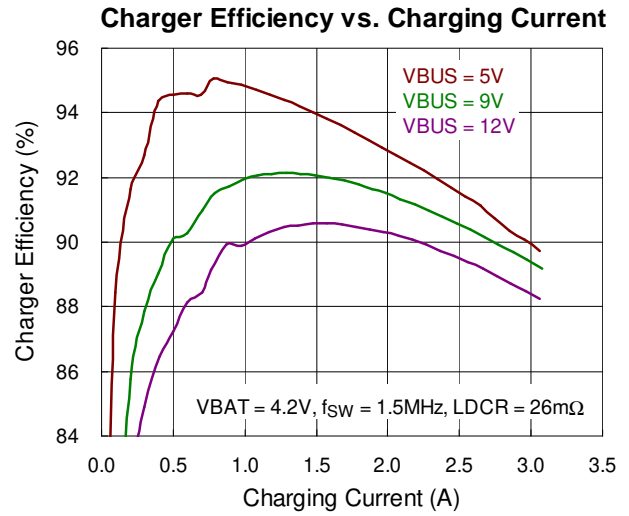
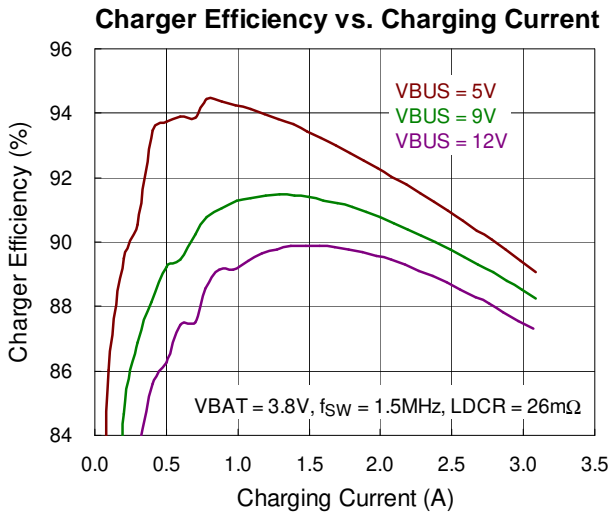



**Buck Switching**

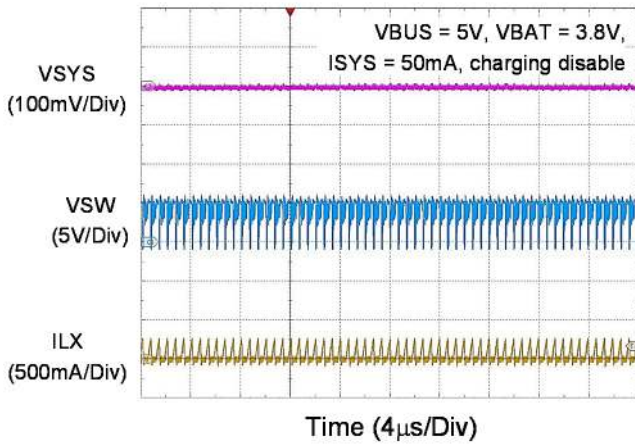

**Buck Switching**

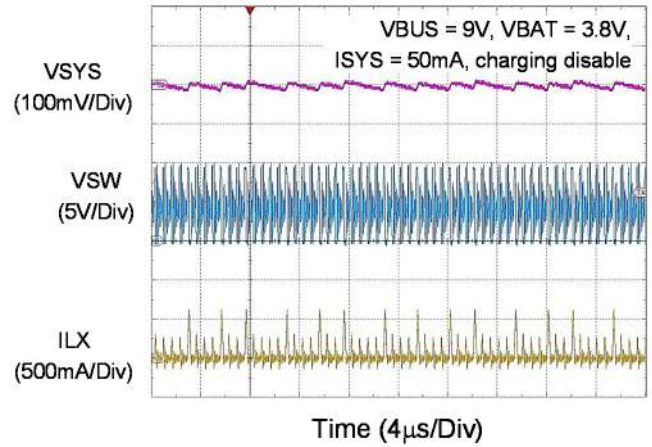

**Buck Switching**

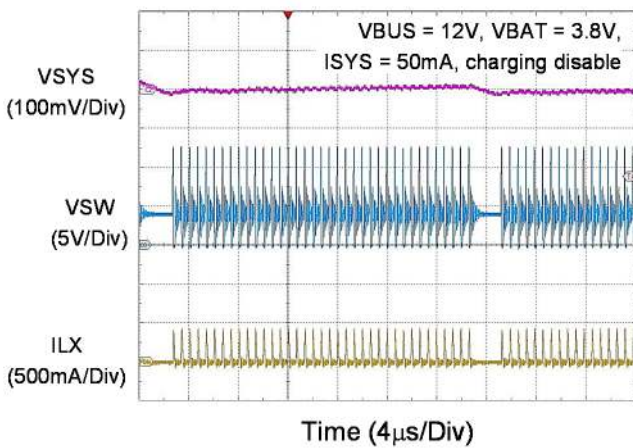

**Buck Switching**

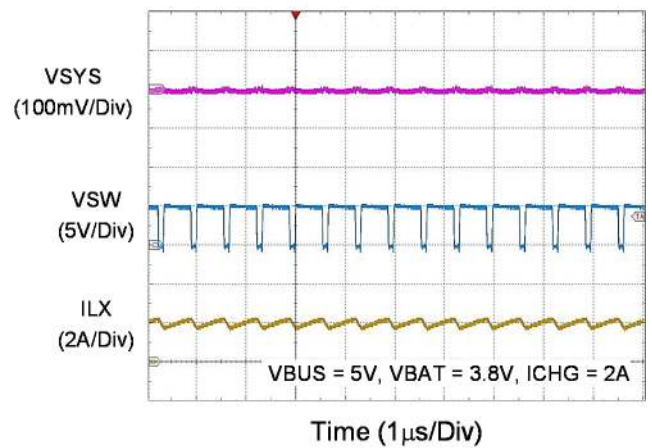

**Buck Switching**

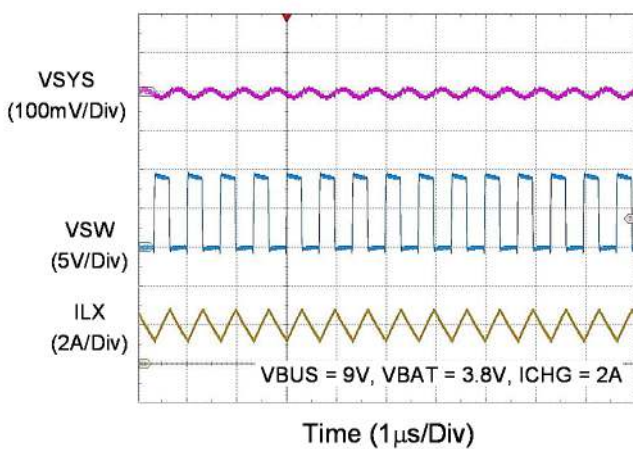

**Buck Switching**

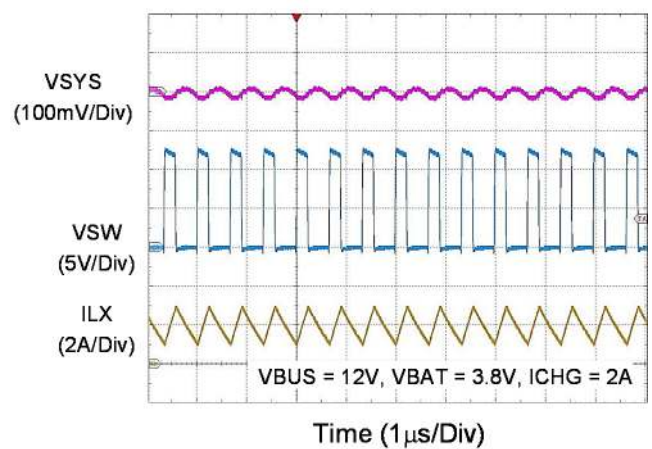



**Charge Enable**

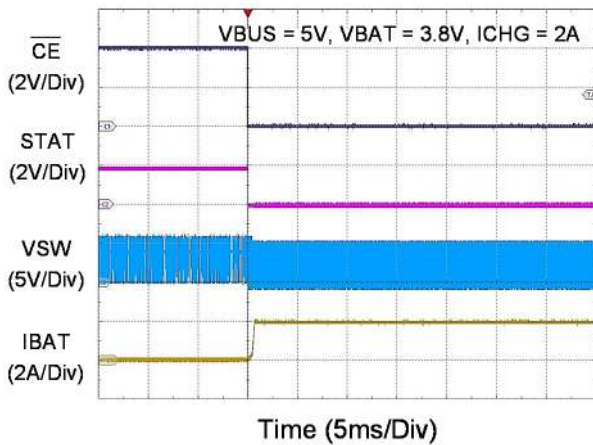

**Charge Disable**

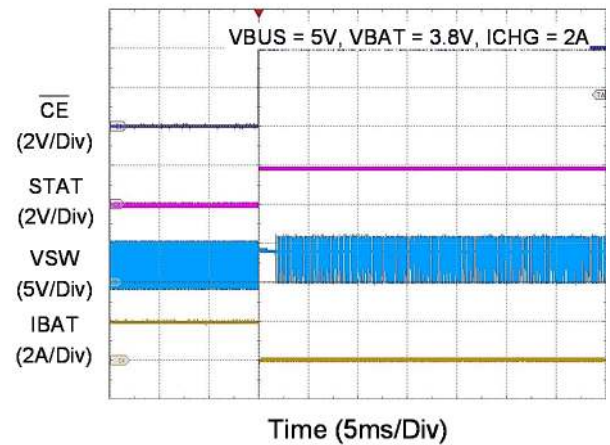

**Boost Switching**

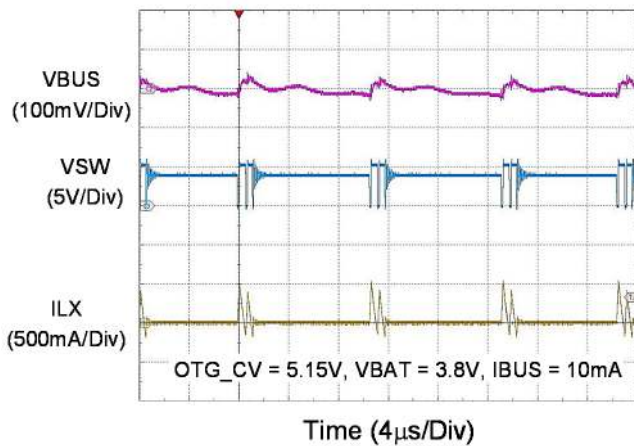

**Boost Switching**

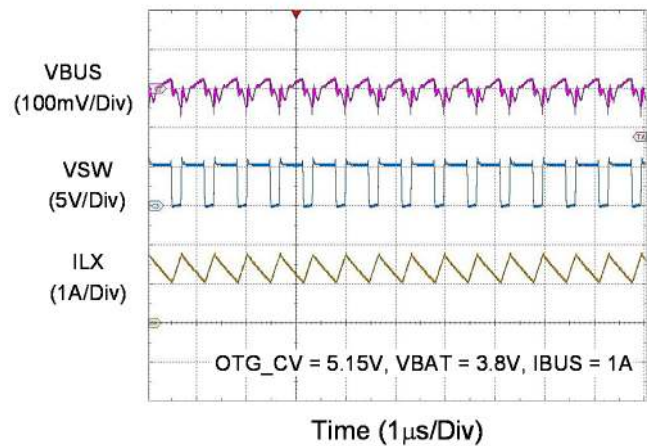

**Boost Start-Up**

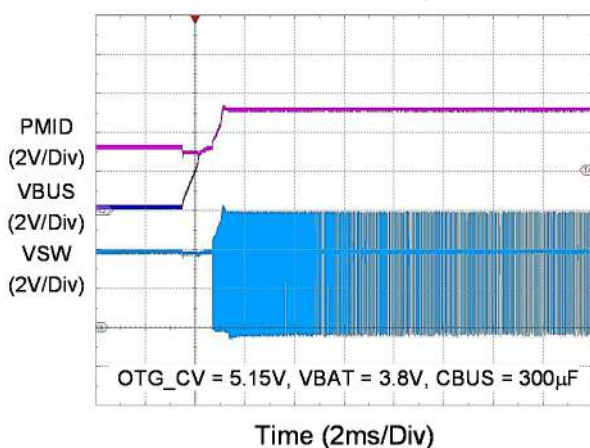

**AICC Enable**

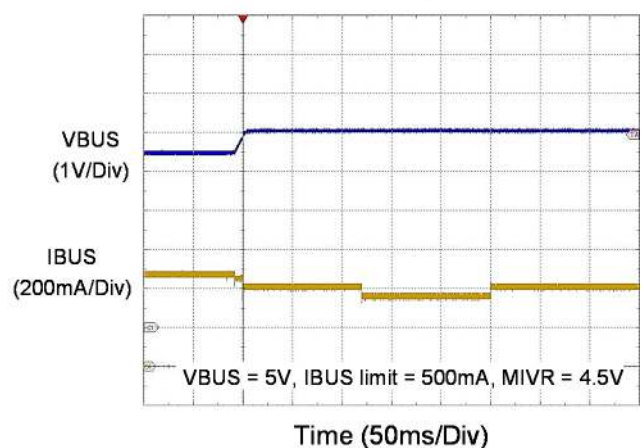

## Register Descriptions

I<sup>2</sup>C Slave Address : 1010011 (53H)

R : Read only

R/W : Read and write

RWSC : Read and write, also automatically set/clear by particular condition

Register Address : 0x00, Register Name : OTG\_CONFIG

Bit	Bit Name	Default	WDT RST	REG RST	Type	Description
7:6	OTG_CV	10	N	Y	R/W	OTG voltage limit regulation 00 : 4.85V 01 : 5.0V 10 : 5.15V (default) 11 : 5.3V
5:2	Reserved	0000	NA	NA	R	Reserved
1	OTG_LBP	0	N	Y	R/W	OTG low battery protection 0 : 2.8V (default) 1 : 2.5V
0	OTG_CC	1	Y	Y	R/W	OTG current limit regulation 0 : 0.5A 1 : 1.2A (default)

Register Address : 0x01, Register Name : TOP

Bit	Bit Name	Default	WDT RST	REG RST	Type	Description
7	$\overline{QON\_RST\_EN}$	1	Y	Y	R/W	0 : $\overline{QON}$ = 0 for 10s will NOT do anything 1 : $\overline{QON}$ = 0 for 10s will turn off BATFET (default)
6	STAT_EN	1	N	Y	R/W	0 : STAT pin function disable 1 : STAT pin function enable (default)
5:4	Reserved	00	NA	NA	R	Reserved
3	DIS_I2C_TO	0	Y	Y	R/W	0 : Enable I <sup>2</sup> C time-out function (default) 1 : Disable I <sup>2</sup> C time-out function
2	WDT_CNT_RST	0	Y	Y	RWSC	0 : No action 1 : Reset watchdog counter (Notice : Back to 0 after watchdog reset)
1:0	WDT	01	Y	Y	R/W	00 : Disable watchdog timer reset function 01 : 40s (default) 10 : 80s 11 : 160s

Register Address : 0x02, Register Name : FUNCTION

Bit	Bit Name	Default	WDT RST	REG RST	Type	Description
7	BATFET_DIS	0	N	Y	RWSC	0 : Allow BATFET turn on (default) 1 : Force BATFET turn off (Notice : Clear by VBUS plug in or $\overline{QON} = 0$ for 1s, auto set BATFET_DIS = 1 by system overload from BAT to SYS)
6	BATFET_DIS_DLY	1	N	Y	R/W	0 : BATFET turn off immediately while BATFET_DIS = 0 1 : BATFET turn off with 12s delay while BATFET_DIS = 1 (default)
5	HZ	0	Y	Y	RWSC	0 : Normal mode (default) 1 : HZ mode (Notice : Clear by VBUS plug in)
4	Reserved	0	NA	NA	R	Reserved
3	BUCK_PFM_DIS	0	N	Y	R/W	0 : Enable PFM (default) 1 : Disable PFM
2	UUG_FULLON	0	N	Y	R/W	0 : Q1 turn on by condition (default) 1 : Force Q1 full on
1	OTG_EN	0	Y	Y	RWSC	0 : Disable OTG (default) 1 : Enable OTG (Notice : Clear by HZ = 1 or $\overline{OTP}$ or $\overline{OTG\_LBP}$ or $\overline{VBUS\_OV}$ or $\overline{QON}$ reset or BATFET_DIS = 1 or auto 7 times hiccup for soft-start fail or overload)
0	CHG_EN	1	Y	Y	R/W	0 : Disable charge 1 : Enable charge (default)

Register Address : 0x03, Register Name : IBUS

Bit	Bit Name	Default	WDT RST	REG RST	Type	Description
7	AICC_EN	0	Y	Y	RWSC	0 : Disable AICC function (default) 1 : Enable AICC function (Notice : Auto clear after AICC function done)
6	AUTO_AICR	1	Y	Y	R/W	0 : No action 1 : Auto set IAICR by BC1.2 done or PSEL change (default)
5:0	IAICR	001010	N	Y	RWSC	Average input current regulation 000000 : 50mA 000001 : 50mA 000010 : 100mA ... 001010 : 500mA (default) ... 111101 : 3050mA 111110 : 3100mA 111111 : 3200mA (Notice : Auto set by BC1.2 done or PSEL change if AUTO_AICR = 1)

Register Address : 0x04, Register Name : VBUS

Bit	Bit Name	Default	WDT RST	REG RST	Type	Description
7:6	VAC_OVP	01	N	Y	R/W	VAC OVP threshold 00 : 5.8V 01 : 6.5V (default) 10 : 10.9V (6.5V while OTG) 11 : 14V (6.5V while OTG)
5:4	VMIVR_BAT_TRACK	00	N	Y	R/W	00 : VMIVR by 0x04[3:0] (default) 01 : VMIVR = VBAT + 200mV 10 : VMIVR = VBAT + 250mV 11 : VMIVR = VBAT + 300mV
3:0	VMIVR	0110	N	Y	R/W	Minimum input voltage regulation 0000 : 3900mV 0001 : 4000mV ... 0110 : 4500mV (default) ... 1110 : 5300mV 1111 : 5400mV

Register Address : 0x05, Register Name : PRECHG

Bit	Bit Name	Default	WDT RST	REG RST	Type	Description
7	Reserved	0	NA	NA	R	Reserved
6:4	VPRE_CHG	100	Y	Y	R/W	Pre-charge voltage threshold 000 : 2700mV 001 : 2800mV 010 : 2900mV 011 : 3000mV 100 : 3100mV (default) 101 : 3200mV 110 : 3300mV 111 : 3400mV
3:0	IPRE_CHG	0010	Y	Y	R/W	Pre-charge current 0000 : 50mA 0001 : 100mA 0010 : 150mA (default) ... 1110 : 750mA 1111 : 800mA

Register Address : 0x06, Register Name : REGU

Bit	Bit Name	Default	WDT RST	REG RST	Type	Description
7	Reserved	0	NA	NA	R	Reserved
6	THREG	1	Y	Y	R/W	Junction thermal regulation threshold 0 : 100°C 1 : 120°C (default)
5:4	Reserved	00	NA	NA	R	Reserved
3:0	VSYS_MIN	1001	N	Y	R/W	System minimum voltage 0000 : 2600mV 0001 : 2700mV ... 1001 : 3500mV (default) ... 1110 : 4000mV 1111 : 4100mV

Register Address : 0x07, Register Name : VCHG

Bit	Bit Name	Default	WDT RST	REG RST	Type	Description
7	VRE_CHG	0	Y	Y	R/W	Re-charge voltage threshold 0 : 100mV (default) 1 : 200mV
6:0	VBAT_REG	0011110	Y	Y	R/W	Charge voltage 0000000 : 3900mV 0000001 : 3910mV ... 0011110 : 4200mV (default) ... 1010000 : 4700mV 1010000 to 1111111 : 4700mV

Register Address : 0x08, Register Name : ICHG

Bit	Bit Name	Default	WDT RST	REG RST	Type	Description
7:6	Reserved	00	NA	NA	R	Reserved
5:0	ICHG_REG	101000	Y	Y	R/W	Charge current 000000 : 0mA (disable charge) 000001 : 50mA 000010 : 100mA 000011 : 150mA ... 101000 : 2000mA (default) ... 111101 : 3100mA 111111 : 3150mA

Register Address : 0x09, Register Name : CHG\_TIMER

Bit	Bit Name	Default	WDT RST	REG RST	Type	Description
7	CHG_SAFE_TMR_EN	1	Y	Y	R/W	0 : Disable charge safe timer 1 : Enable charge safe timer (default)
6	CHG_SAFE_TMR_2XT	1	Y	Y	R/W	Double charge safe timer during MIVR, AICR, thermal regulation, and JEITA reduce ICHG 0 : Disable 2x extended charge safe timer 1 : Enable 2x extended charge safe timer (default)
5:4	CHG_SAFE_TMR	01	Y	Y	R/W	Charge safe timer 00 : 5hr 01 : 10hr (default) 10 : 15hr 11 : 20hr
3:0	Reserved	0000	NA	NA	R	Reserved

Register Address : 0x0A, Register Name : EOC

Bit	Bit Name	Default	WDT RST	REG RST	Type	Description
7:4	IEOC_CHG	0011	Y	Y	R/W	End-of-charge current threshold 0000 : 50mA 0001 : 100mA 0010 : 150mA 0011 : 200mA (default) ... 1110 : 750mA 1111 : 800mA
3:2	BG_CHG_TMR	00	Y	Y	R/W	EOC back-ground charge timer 00 : 0min (default) 01 : 15min 10 : 30min 11 : 45min
1	TE	1	Y	Y	R/W	0 : Disable charge current termination 1 : Enable charge current termination (default)
0	EOC_RST	0	Y	Y	RWSC	0 : No action 1 : Reset EOC (Notice : Back to 0 after reset EOC done)

Register Address : 0x0B, Register Name : INFO

Bit	Bit Name	Default	WDT RST	REG RST	Type	Description
7	REG_RST	0	NA	NA	RWSC	0 : No action 1 : Reset register (Notice : Back to 0 after register reset)
6:3	DEVICE_ID	1001	NA	NA	R	1001 : RT9470 (PSEL, PGB) 1010 : RT9470D (D+, D-)
2:0	DEVICE_RE	NA	NA	NA	R	Revision

Register Address : 0x0C, Register Name : JEITA

Bit	Bit Name	Default	WDT RST	REG RST	Type	Description
7	JEITA_EN	1	Y	Y	R/W	0 : JEITA disable 1 : JEITA enable (default)
6	JEITA_COLD	0	Y	Y	R/W	0 : COLD do NOT charging / OTG (default) 1 : COLD still charging / OTG
5	JEITA_COOL_ISET	1	Y	Y	R/W	0 : 50% of ICHG 1 : 25% of ICHG (default)
4	JEITA_COOL_VSET	1	Y	Y	R/W	0 : VBAT_REG = 4.1V 1 : VBAT_REG = Register setting (default)
3	JEITA_WARM_ISET	1	Y	Y	R/W	0 : 50% of ICHG 1 : ICHG = Register setting (default)
2	JEITA_WARM_VSET	0	Y	Y	R/W	0 : VBAT_REG = 4.1V (default) 1 : VBAT_REG = Register setting
1	JEITA_HOT	0	Y	Y	R/W	0 : HOT do NOT charging / OTG (default) 1 : HOT still charging / OTG
0	Reserved	0	NA	NA	R	Reserved

Register Address : 0x0D, Register Name : PUMP\_EXP

Bit	Bit Name	Default	WDT RST	REG RST	Type	Description
7	PE_EN	0	Y	Y	RWSC	0 : Idle (default) 1 : Trigger MTK Pump Express process (Notice : Auto clear while PE done or no VBUS)
6	PE_SEL	0	Y	Y	R/W	0 : PE 1.0 process select (default) 1 : PE 2.0 process select
5	PE10_INC	0	Y	Y	R/W	0 : PE 1.0 voltage down (default) 1 : PE 1.0 voltage up
4:0	PE20_CODE	00000	Y	Y	R/W	MTK PE 2.0 voltage request setting 00000 : 5.5V (default) 00001 : 6V ... 11101 : 20V 11110 : Adapter healthy self-testing 11111 : Disable cable drop compensation

Register Address : 0x0E, Register Name : DPDM\_DET

Bit	Bit Name	Default	WDT RST	REG RST	Type	Description
7	BC12_EN	1	Y	Y	R/W	0 : Disable BC1.2 detection 1 : Enable BC1.2 detection while VBUS > 3.8V (default) (Notice : For RT9470D only)
6:5	DCDT_SEL	01	Y	Y	R/W	00 : Disable DCD timeout function 01 : Enable 300ms DCD timeout function (default) 10 : Enable 600ms DCD timeout function 11 : Wait data contact
4	SPEC_TA_EN	1	Y	Y	R/W	0 : Disable Samsung / Apple TA detection 1 : Enable Samsung / Apple TA detection (default)
3:1	Reserved	000	NA	NA	R	Reserved
0	DCP_DP_OPT	0	Y	Y	R/W	DCP DP behavior option 0 : DP = 0V after BC 1.2 done (default) 1 : DP keep 0.6V while DCP port detected



Register Address : 0x0F, Register Name : IC\_STATUS

Bit	Bit Name	Default	WDT RST	REG RST	Type	Description
7:4	PORT_STAT	0000	NA	NA	R	0000 : No information 0001 to 0111 : Reserved 1000 : VBUS = device 1 (2100mA-APPLE-10w) 1001 : VBUS = device 2 (2000mA-SAMSUNG-10w) 1010 : VBUS = device 3 (1000mA-APPLE-5w) 1011 : VBUS = device 4 (2400mA-APPLE-12w) 1100 : VBUS = unknown / NSDP (500mA) 1101 : VBUS = SDP (500mA) / PSEL = High 1110 : VBUS = CDP (1500mA) 1111 : VBUS = DCP (2400mA) / PSEL = Low
3:0	IC_STAT	0000	NA	NA	R	0000 : HZ/SLEEP 0001 : VBUS ready for charge 0010 : Trickle-charge 0011 : Pre-charge 0100 : Fast-charge 0101 : IEOC-charge (EOC and TE = 0) 0110 : Back-Ground charge (EOC and TE = 1 and before turn off power path) 0111 : Charge done (EOC and TE = 1 and power path off) 1000 : Charge fault (VAC_OV / CHG_BUSUV / CHG_TOUT / CHG_SYSOV / CHG_BATOV / JEITA_HOT / JEITA_COLD / OTP) 1001 to 1110 : Reserved 1111 : OTG

Register Address : 0x10, Register Name : STAT0

Bit	Bit Name	Default	WDT RST	REG RST	Type	Description
7	ST_VBUS_GD	0	NA	NA	R	0 : VBUS is not good 1 : VBUS is good (Notice : After current capability of the input source detection, and HZ = 0, VAC_OV = 0, VBUS > 3.8V)
6	ST_CHG_RDY	0	NA	NA	R	0 : VBUS is not ready for charging 1 : VBUS is ready for charging (Notice : After port detection, and HZ = 0, VAC_OV = 0, VBUS > 3.8V)
5	ST_IEOC	0	NA	NA	R	0 : Not in EOC state 1 : While in EOC state (Notice : Charge current < IEOC level)
4	ST_BG_CHG	0	NA	NA	R	0 : Not in EOC state or TE = 0 or BG_CHG_TMR = 00 1 : While in EOC state and TE = 1 and BG_CHG_TMR ≠ 00
3	ST_CHG_DONE	0	NA	NA	R	0 : Not in EOC state or BATFET on 1 : While in EOC state and BATFET off
2:1	Reserved	00	NA	NA	R	Reserved
0	ST_BC12_DONE	0	NA	NA	R	0 : BC1.2 process not ready 1 : While BC1.2 process done

Register Address : 0x11, Register Name : STAT1

Bit	Bit Name	Default	WDT RST	REG RST	Type	Description
7	ST_CHG_MIVR	0	NA	NA	R	0 : Not in MIVR loop 1 : While in MIVR loop
6	ST_CHG_AICR	0	NA	NA	R	0 : Not in AICR loop 1 : While in AICR loop
5	ST_CHG_THREG	0	NA	NA	R	0 : Not in THERMAL loop 1 : While in THERMAL loop
4	ST_CHG_BUSUV	0	NA	NA	R	0 : Not VBAT < VBUS < 3.8V 1 : While VBAT < VBUS < 3.8V
3	ST_CHG_TOUT	0	NA	NA	R	0 : Not in charge safety time-out 1 : While in charge safety time-out
2	ST_CHG_SYSOV	0	NA	NA	R	0 : Not in SYS OV 1 : While in SYS OV
1	ST_CHG_BATOV	0	NA	NA	R	0 : Not in BAT OV 1 : While in BAT OV
0	Reserved	0	NA	NA	R	Reserved

Register Address : 0x12, Register Name : STAT2

Bit	Bit Name	Default	WDT RST	REG RST	Type	Description
7	ST_JEITA_HOT	0	NA	NA	R	0 : Not in BAT is hot 1 : While in BAT is hot
6	ST_JEITA_WARM	0	NA	NA	R	0 : Not in BAT is warm 1 : While in BAT is warm
5	ST_JEITA_COOL	0	NA	NA	R	0 : Not in BAT is cool 1 : While in BAT is cool
4	ST_JEITA_COLD	0	NA	NA	R	0 : Not in BAT is cold 1 : While in BAT is cold
3:2	Reserved	00	NA	NA	R	Reserved
1	ST_SYS_MIN	0	NA	NA	R	0 : Not in VBAT < VSYS_MIN 1 : While in VBAT < VSYS_MIN
0	Reserved	0	NA	NA	R	Reserved

Register Address : 0x13, Register Name : STAT3

Bit	Bit Name	Default	WDT RST	REG RST	Type	Description
7	ST_OTP	0	NA	NA	R	0 : Not OTP 1 : OTP
6	ST_VAC_OV	0	NA	NA	R	0 : Not VAC_OV 1 : VAC_OV (charge or OTG mode)
5	ST_WDT	0	NA	NA	R	0 : WDT is counting 1 : WDT reset will occur after 500ms
4:3	Reserved	00	NA	NA	R	Reserved
2	ST_OTG_CC	0	NA	NA	R	0 : Not in OTG_CC 1 : While in OTG_CC
1:0	Reserved	00	NA	NA	R	Reserved

Register Address : 0x20, Register Name : IRQ0

Bit	Bit Name	Default	WDT RST	REG RST	Type	Description
7	FL_VBUS_GD	0	NA	NA	R	0 : ST_VBUS_GD not rising 1 : While ST_VBUS_GD rising, read clear
6	FL_CHG_RDY	0	NA	NA	R	0 : ST_CHG_RDY not rising 1 : While ST_CHG_RDY rising, read clear
5	FL_IEOC	0	NA	NA	R	0 : ST_IEOC not rising 1 : While ST_IEOC rising, read clear
4	FL_BG_CHG	0	NA	NA	R	0 : ST_BG_CHG not rising 1 : While ST_BG_CHG rising, read clear
3	FL_CHG_DONE	0	NA	NA	R	0 : ST_CHG_DONE not rising 1 : While ST_CHG_DONE rising, read clear
2	FL_RECHG	0	NA	NA	R	0 : While VBAT > VRECHG after EOC 1 : While VBAT < VRECHG after EOC, read clear
1	FL_DETACH	0	NA	NA	R	0 : ST_VBUS_GD not rising or in ST_VBUS_GD 1 : While ST_VBUS_GD falling then VBUS < VBAT or VBUS < 3.3V, read clear
0	FL_BC12_DONE	0	NA	NA	R	0 : BC1.2 process not ready 1 : While BC1.2 process done

Register Address : 0x21, Register Name : IRQ1

Bit	Bit Name	Default	WDT RST	REG RST	Type	Description
7	FL_CHG_MIVR	0	NA	NA	R	0 : ST_CHG_MIVR not rising 1 : While ST_CHG_MIVR rising, read clear
6	FL_CHG_AICR	0	NA	NA	R	0 : ST_CHG_AICR not rising 1 : While ST_CHG_AICR rising, read clear
5	FL_CHG_THREG	0	NA	NA	R	0 : ST_CHG_THREG not rising 1 : While ST_CHG_THREG rising, read clear
4	FL_CHG_BUSUV	0	NA	NA	R	0 : ST_CHG_BUSUV not rising 1 : While ST_CHG_BUSUV rising, read clear
3	FL_CHG_TOUT	0	NA	NA	R	0 : ST_CHG_TOUT not rising 1 : While ST_CHG_TOUT rising, read clear
2	FL_CHG_SYSOV	0	NA	NA	R	0 : ST_CHG_SYSOV not rising 1 : While ST_CHG_SYSOV rising, read clear
1	FL_CHG_BATOV	0	NA	NA	R	0 : ST_CHG_BATOV not rising 1 : While ST_CHG_BATOV rising, read clear
0	Reserved	0	NA	NA	R	Reserved

Register Address : 0x22, Register Name : IRQ2

Bit	Bit Name	Default	WDT RST	REG RST	Type	Description
7	FL_JEITA_HOT	0	NA	NA	R	0 : ST_JEITA_HOT not rising 1 : While ST_JEITA_HOT rising, read clear
6	FL_JEITA_WARM	0	NA	NA	R	0 : ST_JEITA_WARM not rising 1 : While ST_JEITA_WARM rising, read clear
5	FL_JEITA_COOL	0	NA	NA	R	0 : ST_JEITA_COOL not rising 1 : While ST_JEITA_COOL rising, read clear
4	FL_JEITA_COLD	0	NA	NA	R	0 : ST_JEITA_COLD not rising 1 : While ST_JEITA_COLD rising, read clear
3	FL_PE_DONE	0	NA	NA	R	0 : FL_PE_DONE not rising 1 : While PE processing done, read clear
2	FL_AICC_DONE	0	NA	NA	R	0 : FL_AICC_DONE not rising 1 : While AICC processing done, read clear
1	FL_SYS_MIN	0	NA	NA	R	0 : ST_SYS_MIN not rising 1 : While ST_SYS_MIN rising, read clear
0	FL_SYS_SHORT	0	NA	NA	R	0 : ST_SYS_SHORT not rising 1 : While ST_SYS_SHORT rising, read clear

Register Address : 0x23, Register Name : IRQ3

Bit	Bit Name	Default	WDT RST	REG RST	Type	Description
7	FL_OTP	0	NA	NA	R	0 : ST_OTP not rising 1 : While ST_OTP rising, read clear
6	FL_VAC_OV	0	NA	NA	R	0 : ST_VAC_OV not rising 1 : While ST_VAC_OV rising, read clear
5	FL_WDT	0	NA	NA	R	0 : ST_WDT not rising 1 : While ST_WDT rising, read clear
4:3	Reserved	00	NA	NA	R	Reserved
2	FL_OTG_CC	0	NA	NA	R	0 : ST_OTG_CC not rising 1 : While ST_OTG_CC rising, read clear
1	FL_OTG_LBP	0	NA	NA	R	0 : ST_OTG_LBP not rising 1 : While ST_OTG_LBP rising, read clear
0	FL_OTG_FAULT	0	NA	NA	R	0 : ST_OTG_FAULT not rising 1 : While ST_OTG_FAULT rising, read clear

Register Address : 0x30, Register Name : MASK0

Bit	Bit Name	Default	WDT RST	REG RST	Type	Description
7	MK_VBUS_GD	1	N	Y	R/W	0 : Not mask IRQ of FL_VBUS_GD 1 : Mask IRQ of FL_VBUS_GD (default)
6	MK_CHG_RDY	1	N	Y	R/W	0 : Not mask IRQ of FL_CHG_RDY 1 : Mask IRQ of FL_CHG_RDY (default)
5	MK_IEOC	1	N	Y	R/W	0 : Not mask IRQ of FL_IEOC 1 : Mask IRQ of FL_IEOC (default)
4	MK_BG_CHG	1	N	Y	R/W	0 : Not mask IRQ of MK_BG_CHG 1 : Mask IRQ of MK_BG_CHG (default)
3	MK_CHG_DONE	1	N	Y	R/W	0 : Not mask IRQ of FL_CHG_DONE 1 : Mask IRQ of FL_CHG_DONE (default)
2	MK_RECHG	1	N	Y	R/W	0 : Not mask IRQ of FL_RECHG 1 : Mask IRQ of FL_RECHG (default)
1	MK_DETACH	1	N	Y	R/W	0 : Not mask IRQ of FL_DETACH 1 : Mask IRQ of FL_DETACH (default)
0	MK_BC12_DONE	1	N	Y	R/W	0 : Not mask IRQ of FL_BC12_DONE 1 : Mask IRQ of FL_BC12_DONE (default)

Register Address : 0x31, Register Name : MASK1

Bit	Bit Name	Default	WDT RST	REG RST	Type	Description
7	MK_CHG_MIVR	1	N	Y	R/W	0 : Not mask IRQ of FL_CHG_MIVR 1 : Mask IRQ of FL_CHG_MIVR (default)
6	MK_CHG_AICR	1	N	Y	R/W	0 : Not mask IRQ of FL_CHG_AICR 1 : Mask IRQ of FL_CHG_AICR (default)
5	MK_CHG_THREG	1	N	Y	R/W	0 : Not mask IRQ of FL_CHG_THREG 1 : Mask IRQ of FL_CHG_THREG (default)
4	MK_CHG_BUSUV	1	N	Y	R/W	0 : Not mask IRQ of FL_CHG_BUSUV 1 : Mask IRQ of FL_CHG_BUSUV (default)
3	MK_CHG_TOUT	1	N	Y	R/W	0 : Not mask IRQ of FL_CHG_TOUT 1 : Mask IRQ of FL_CHG_TOUT (default)
2	MK_CHG_SYSOV	1	N	Y	R/W	0 : Not mask IRQ of FL_CHG_SYSOV 1 : Mask IRQ of FL_CHG_SYSOV (default)
1	MK_CHG_BATOV	1	N	Y	R/W	0 : Not mask IRQ of FL_CHG_BATOV 1 : Mask IRQ of FL_CHG_BATOV (default)
0	Reserved	1	NA	NA	R	Reserved

Register Address : 0x32, Register Name : MASK2

Bit	Bit Name	Default	WDT RST	REG RST	Type	Description
7	MK_JEITA_HOT	1	N	Y	R/W	0 : Not mask IRQ of FL_JEITA_HOT 1 : Mask IRQ of FL_JEITA_HOT (default)
6	MK_JEITA_WARM	1	N	Y	R/W	0 : Not mask IRQ of FL_JEITA_WARM 1 : Mask IRQ of FL_JEITA_WARM (default)
5	MK_JEITA_COOL	1	N	Y	R/W	0 : Not mask IRQ of FL_JEITA_COOL 1 : Mask IRQ of FL_JEITA_COOL (default)
4	MK_JEITA_COLD	1	N	Y	R/W	0 : Not mask IRQ of FL_JEITA_COLD 1 : Mask IRQ of FL_JEITA_COLD (default)
3	MK_PE_DONE	1	N	Y	R/W	0 : Not mask IRQ of FL_PE_DONE 1 : Mask IRQ of FL_PE_DONE (default)
2	MK_AICC_DONE	1	N	Y	R/W	0 : Not mask IRQ of FL_AICC_DONE 1 : Mask IRQ of FL_AICC_DONE (default)
1	MK_SYS_MIN	1	N	Y	R/W	0 : Not mask IRQ of FL_SYS_MIN 1 : Mask IRQ of FL_SYS_MIN (default)
0	MK_SYS_SHORT	1	N	Y	R/W	0 : Not mask IRQ of FL_SYS_SHORT 1 : Mask IRQ of FL_SYS_SHORT (default)

Register Address : 0x33, Register Name : IRQ3

Bit	Bit Name	Default	WDT RST	REG RST	Type	Description
7	MK_OTP	1	N	Y	R/W	0 : Not mask IRQ of FL_OTP 1 : Mask IRQ of FL_OTP (default)
6	MK_VAC_OV	1	N	Y	R/W	0 : Not mask IRQ of FL_VAC_OV 1 : Mask IRQ of FL_VAC_OV (default)
5	MK_WDT	1	N	Y	R/W	0 : Not mask IRQ of FL_WDT 1 : Mask IRQ of FL_WDT (default)
4:3	Reserved	11	NA	NA	R	Reserved
2	MK_OTG_CC	1	N	Y	R/W	0 : Not mask IRQ of FL_OTG_CC 1 : Mask IRQ of FL_OTG_CC (default)
1	MK_OTG_LBP	1	N	Y	R/W	0 : Not mask IRQ of FL_OTG_LBP 1 : Mask IRQ of FL_OTG_LBP (default)
0	MK_OTG_FAULT	1	N	Y	R/W	0 : Not mask IRQ of FL_OTG_FAULT 1 : Mask IRQ of FL_OTG_FAULT (default)

## Application Information

### Power Up

#### • Power-On-Reset (POR)

The device powers internal bias circuits from the higher voltage of VBUS and VBAT. When VBUS rises above 1.8V or VBAT rises above VBAT\_UVLO, I<sup>2</sup>C interface is ready for communication and all the registers are reset to default value.

#### • Device Power Up from Battery Only

When only Battery is present and VBAT above VBAT\_DPL\_RISE, the BATFET turns on to connect VBAT to VSYS. The REGN stays off to minimize the quiescent current. The low quiescent current on VBAT and low R<sub>DS(ON)</sub> of BATFET minimize device power consumption and conduction loss maximum battery run life.

The device always monitors the discharge current through BATFET (Battery Supply Mode). When the system is overloaded or shorted (IBAT > IBATFET\_OCP), the device turns off BATFET immediately and sets BATFET\_DIS = 1 to enter Shipping Mode until VBUS plugs in again or uses the methods to exit Shipping Mode to re-enable BATFET.

#### • Device Power Up from VBUS

When the VBUS is plugged in, the power up sequence is as listed :

1. Power up REGN LDO.
2. Poor Source Detection.
3. PORT\_STAT Detection is based on PSEL or input source type to set default Average Input Current Regulation (AICR) register.
4. Minimum Input Voltage Regulation (MIVR) setting.
5. Buck Converter Power-up.

#### • Power-Up REGN LDO

The REGN LDO supplies the High-side and Low-side MOSFET gate drive. The REGN also provides bias to TS external resistor and pull-up rail of STAT. The REGN is enabled when the below conditions are valid :

1. VAC above VBAT + VSLEEP\_RISE in buck mode or enable OTG bit in boost mode.
2. After 220ms delay is completed when VAC above VBAT + VSLEEP\_RISE.
3. REGN LDO turns off when device in HZ mode, sleep mode, VBUS over-voltage or OTG disable.

#### • Poor Source Detection

After REGN powers up, the device checks the current capability of the input source. The input source has to meet following requirements to turn on the buck converter.

1. VBUS below VAC\_OVP\_RISE.
2. VBUS above VBUS\_BAD\_ADP then pulling IBADSRC (typical = 40mA).

When input source passes above conditions, the ST\_VBUS\_GD and the FL\_VBUS\_GD turn to high and INT pin is pulsed for interrupting the host. If ST\_VBUS\_GD doesn't turn to high, it repeats poor source detection every 2 seconds.

#### • VBUS Source Type Detection

After ST\_VBUS\_GD turns to high, the device runs VBUS source type detection (RT9470D) or PSEL pin status (RT9470). After detection is completed, the ST\_CHG\_RDY and the FL\_CHG\_RDY turn to high and INT pin is pulsed for interrupting the host.

Then the following registers are changed:

1. Average Input Current Regulation (AICR) register is changed to the result of VBUS source type detection or PSEL pin status automatically if AUTO\_AICR = 1.
2. PORT\_STAT bit is updated to indicate VBUS source type.

#### • Average Input Current Regulation (AICR)

The charger input current is always limited by AICR register. The range of AICR is from 50mA to 3.2A with 50mA resolution.

1. If the bit AUTO\_AICR is set to 0, the device can't change AICR automatically after VBUS source type detection.



2. The host can over-write AICR register to change input current limit.
3. The AICR register setting from PSEL in the RT9470 refers to Table 1 or from D+/D- detection (include standard USB BC 1.2) in the RT9470D refers to Table 2.
4. PSEL value updates AICR in real time in RT9470.
5. D+/D- detect value updates AICR after BC12\_EN disable then enable or re-plug VBUS in the RT9470D.

**Table 1. AICR Setting from PSEL**

PSEL pin	AICR setting	PORT_STAT
High	0.5 A	1101
Low	2.4 A	1111

**Table 2. AICR Setting from D+/D- Detection**

Detection	AICR setting	PORT_STAT
Device 1	2.1A	1000
Device 2	2A	1001
Device 3	1A	1010
Device 4	2.4A	1011
Unknown/NSDP	0.5A	1100
SDP	0.5A	1101
CDP	1.5A	1110
DCP	2.4A	1111

• **Minimum Input Voltage Regulation (MIVR)**

The MIVR function prevents input voltage drops due to insufficient current provided from input power source. The VBUS voltage decreases to VMIVR setting level when the over-current condition of input power source occurs. The VMIVR register default setting is 4.5V, it can be set by I<sup>2</sup>C interface, the range from 3.9V to 5.4V with 0.1V resolution. In addition, the device provides MIVR tracking function by enabling VMIVR\_BAT\_TRACK register bits. If this tracking function is enabled, the MIVR will be the higher of the VMIVR register and VBAT + VMIVR\_BAT\_TRACK offset.

• **Buck Converter Power-Up**

After the AICR is set, the converter is enabled and starts switching. BATFET stays on unless charger is disabled (CHG\_EN = 0) or enters shipping mode (BATFET\_DIS = 1).

The device integrates a synchronous PWM controller with 1.5MHz switching frequency, high-accuracy current and voltage regulation. The device also supports PFM control to improve light-load efficiency. The BUCK\_PFM\_DIS register bit can be used to prevent PFM operation in buck configuration.

• **Boost Mode Operation (OTG)**

The device supports OTG (On-The-Go) mode by boost converter operation to deliver power from battery to other portable devices. The maximum boost mode output current is up to 1.2A, which includes USB OTG 500mA output requirement.

The boost operation can be enabled by following condition :

1. VBAT above VOTG\_LBP
2. VBUS less than VBAT+VSLEEP\_FALL
3. OTG\_EN is set to high
4. Voltage at TS pin is within acceptable range (V<sub>VTS\_HOT</sub> < V<sub>VTS</sub> < V<sub>VTS\_COLD</sub>)
5. After 30ms delay from OTG\_EN is set to high, boost converter powers up.

In boost mode, the IC\_STAT register bits is updated to 1111, the VBUS output voltage is 5.15V and output limit current is 1.2A by default, output voltage (OTG\_CV) and output current limit (OTG\_CC) can be selected through I<sup>2</sup>C. The boost output maintained when VBAT is above VOTG\_LBP.

**Watchdog Timer (WDT)**

When the device is controlled by host, most of the registers can be programmed by host. The host has to write WDT\_CNT\_RST = 1 to reset counter before watchdog timeout and it can also disable WDT function by setting WDT bits to 00.

When the watchdog timer expired, ST\_WDT and FL\_WDT turn to high and  $\overline{\text{INT}}$  pin is pulsed for interrupting the host. After delay 512ms, the related registers are reset to default values. (Refer to Register

Descriptions for detail). If the device is watchdog timeout status, host can write any registers or

WDT\_CNT\_RST = 1 to return counting.

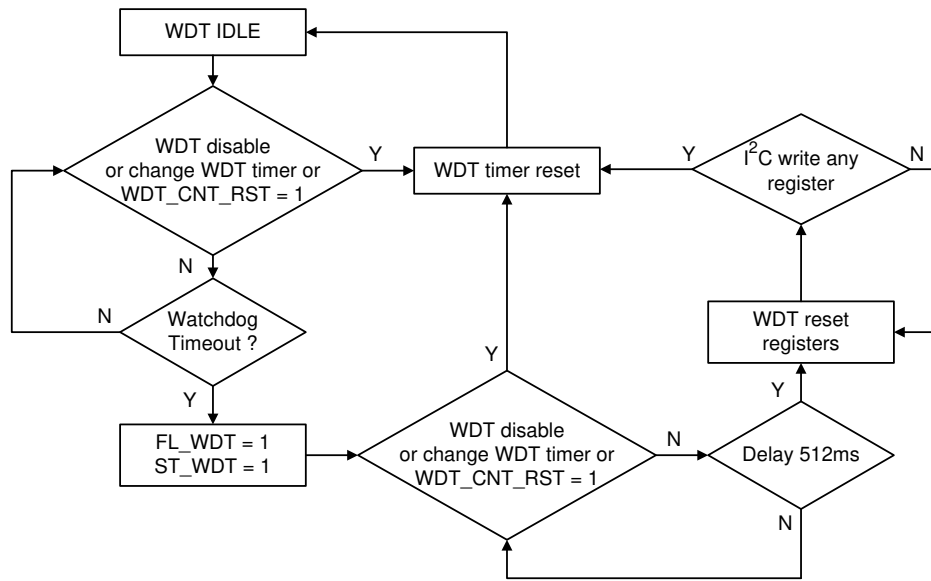

Figure 1. WDT Flow Chart

**Power Path Management**

The device provides automatic power path selection to supply system (VSYS) from VBUS, VBAT (battery) or both of them.

**• Enter Shipping Mode (BATFET Disable)**

To extend battery life when shipping or storage, the device can turn off BATFET to minimize battery leakage current. The host can set BATFET\_DIS bit to turn off BATFET immediately or set BATFET\_DIS\_DLY to delay tSHIP\_MODE\_ENTER to turn off BATFET.

**• Exit Shipping Mode (BATFET Enable)**

When in shipping mode, one of the following methods can exit shipping mode to restore power for system :

1. VBUS plug in.
2. Set BATFET\_DIS bit to 0.
3. Set REG\_RST bit to reset all registers to default.
4. Press QON pin from high to low longer than tSHIPMODE\_EXIT.

**• QON Pin Operations**

The QON pin has two function to control BATFET.

1. BATFET Enable : QON pin transition from high to low with longer than tSHIPMODE\_EXIT deglitch turns on BATFET to exit shipping mode.
2. SYSTEM Reset : QON pin transition from high to low with longer than tQON\_RST deglitch and VBUS is not plugged in, it turns off BATFET for tBATFET\_RST then it is re-enabled BATFET. This function allows system connect to VSYS to do power-on-reset. This function can be disabled by setting QON\_RST\_EN bit to 0.

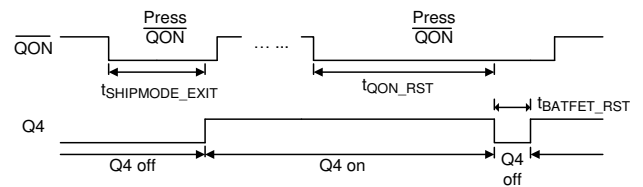

Figure 2. QON Timing

**Battery Charging Management**

The device has charge current up to 3.15A with 18mΩ BATFET to improve charge efficiency and decrease voltage drop during battery discharging.

**• Charging Cycle**

When battery charging is enabled ( $\overline{CE}$  pin set to low and  $CHG\_EN = 1$ ), the device autonomously completes a charging cycle without host controls. The device default parameters refers as Table 2. The host can also change charging parameters through I<sup>2</sup>C.

**Table 3. Default Charging Parameters**

Default Mode	RT9470/D
Charging Voltage	4.2V
Charging Current	2A
Pre-Charge Current	150mA
End of Charge(EOC) Current	200mA
Temperature Profile	JEITA
Fast Charge Safety Timer	10 Hours

A charging cycle starts with following condition :

1. Buck converter starts.

2. Battery charging is enabled ( $\overline{CE}$  pin is low,  $CHG\_EN = 1$  and  $ICHG\_REG$  is not 0mA).
3. Without any thermal fault on TS.
4. No safety timer fault.
5. BATFET is turned on ( $BATFET\_DIS = 0$ ).

The charger is in end of charge status when the charging current is below EOC current threshold, battery voltage is above recharge voltage threshold, and device not in AICR, MIVR or thermal regulation.

When battery voltage is discharged below recharge threshold (threshold setting through  $VRE\_CHG$  register bits), the device restarts a new charging cycle automatically. After the charge is done, toggle  $\overline{CE}$  pin or  $CHG\_EN$  can restart a new charging cycle.

**• Battery Charging Profile**

The device charges the battery in five status : trickle charge, pre-charge, constant current, constant voltage and back-ground charge (optional).

**Table 4. Charging Current Setting**

Current Parameter	Default Current Setting	IC_STAT
I <sub>TRICKLE_CHG</sub>	100mA	0010
I <sub>PRE_CHG</sub>	150mA	0011
I <sub>CHG_REG</sub>	2A	0100
I <sub>EOC_CHG</sub>	200mA	0111

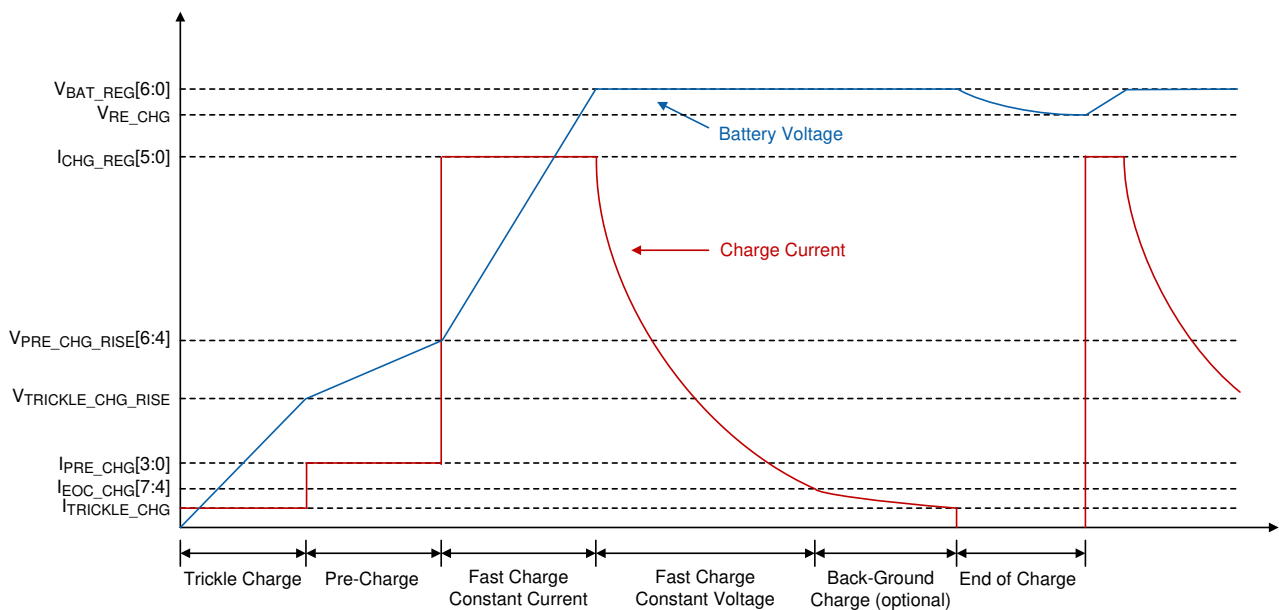

**Figure 3. Charging Profile**

## • End of Charge (EOC)

The charger enters end of charge status when battery voltage is above recharge threshold, and the charge current is below IEOC\_CHG. IEOC\_CHG setting range is from 50mA to 800mA with 50mA resolution. After EOC, the BATFET turns off with TE = 1 and BG\_CHG\_TMR = 00, and the buck converter keeps

switching to supply power to the system. BATFET will turn on again when battery voltage is under recharge voltage threshold or device is in Battery Supply Mode during EOC.

When EOC occurs, there are four conditions as below :

**Table 5. EOC Status Scenario**

	TE = 1 BG_CHG_TMR (disable)	TE = 1 BG_CHG_TMR (counting)	TE = 1 BG_CHG_TMR (timeout)	TE = 0 BG_CHG_TMR (disable)
ST_EOC	1	1	1	1
ST_CHG_DONE	1	0	1	0
ST_BG_CHG	0	1	0	0
STAT Pin	High	High	High	Low
IC_STAT	0111	0110	0111	0101
BATFET	OFF	ON	OFF	ON

1. If the device triggers AICR, MIVR, JEITA or thermal regulation status during charging, the actual charging current will be less than programmed value. In this condition, EOC function will be disabled and the safety timer's counter clock rate will be half.
2. The back-ground charge can be applied after EOC is detected. The back-ground charge is enabled by setting BG\_CHG\_TMR and TE = 1 only. When back-ground charge occurs, the IC\_STAT is set to 0110, and the BATFET will turn off after back-ground charge timer expires.
3. The BG\_CHG\_TMR gets reset at one of the following conditions :
  - ▶ CHG\_EN disable to enable
  - ▶ EOC status re-trigger
  - ▶ EOC\_RST bit is set
  - ▶ REG\_RST bit is set
  - ▶ BG\_CHG\_TMR value changes

An  $\overline{\text{INT}}$  pulse is asserted to host when entering back-ground charge and back-ground charge timer expires.

## • Optimized VDS on BATFET

The device deploys power path function with BATFET separating system from battery. The minimum system voltage is set by VSYS\_MIN bits (default 3.5V).

When the battery voltage is under VSYS\_MIN setting, the BATFET operates in linear mode (LDO mode) and the system voltage is typically 200mV above the VSYS\_MIN setting. When the battery voltage rises above VSYS\_MIN, BATFET turns fully on to minimize RDS(ON) for optimizing VDS (voltage difference between VSYS and VBAT) on BATFET.

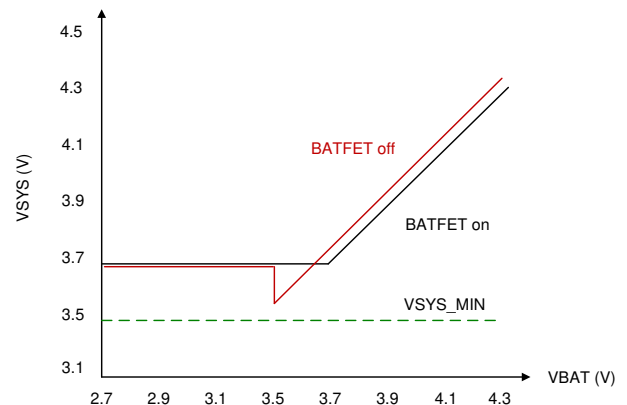

Figure 4. VSYS vs. VBAT

When BATFET turns off and battery voltage is above VSYS\_MIN, the system is regulated at typically 50mV above battery voltage. The status register ST\_SYS\_MIN = 1 when the system is in minimum system voltage regulation.

• **Power Management System**

To apply maximum current and avoid over loading from the power source on VBUS, the device’s Power Management System continuously monitors the power source voltage and current. When power source is overloaded, either the current exceeds the AICR or the voltage drops to MIVR, the device will reduce the charge current to priority power energy for system.

When the charge current is reduced to zero, but power source still triggers AICR or MIVR, the VSYS starts to drop. Once the VSYS drops under VBAT, the device automatically change to battery supply mode, and the BATFET turns fully on and battery starts to discharge so that the system is supported from both battery and power source.

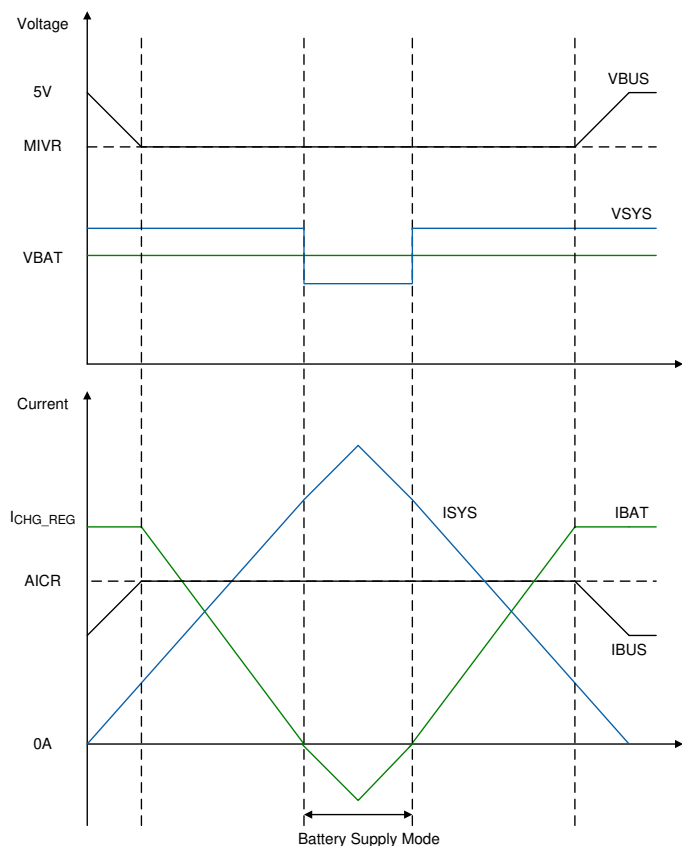

Figure 5. Power Management System

• **Battery Supply Mode**

During charge status, when voltage difference between VBAT and VSYS above 50mV, the BATFET turns on and the BATFET gate is regulated the gate driver of BATFET to minimize VBAT-VSYS voltage stays at 40mV to prevent entering and exiting the battery supply mode frequently. When the voltage of VBAT-VSYS below 0mV, the charger exits the battery supply mode, and starts to charge battery.

• **JEITA Protection During Charge Mode**

The device provides a single thermistor input for temperature monitor.

To achieve battery thermal protection, JEITA guidelines were released in 2007.

To start a charge cycle, the voltage on TS pin must be in the T1 to T4 range. The device will stop charging if the battery temperature is lower than T1 (Cold) or higher than T4 (Hot) with JEITA\_COLD = 0 and JEITA\_HOT = 0.

In this case, the IC\_STAT = 1000 for charge fault and an  $\overline{\text{INT}}$  is asserted to the host.

In cool temperature range (T1 to T2), the charge current is reduced to 50% or 25% of ICHG\_REG (configured by JEITA\_COOL\_ISET).

In warm temperature range (T3 to T4), the voltage setting of VBAT\_REG is reduced to 4.1V or the same as VBAT\_REG (configured by JEITA\_WARM\_VSET).

The device provides more flexible settings than JEITA requirement.

In cool temperature range (T1 to T2), the charger can set voltage of VBAT\_REG down to 4.1V (configured by JEITA\_COOL\_VSET).

In warm temperature range (T3 to T4), the charge current can be reduced to 50% of ICHG\_REG (configured by JEITA\_WARM\_ISET).

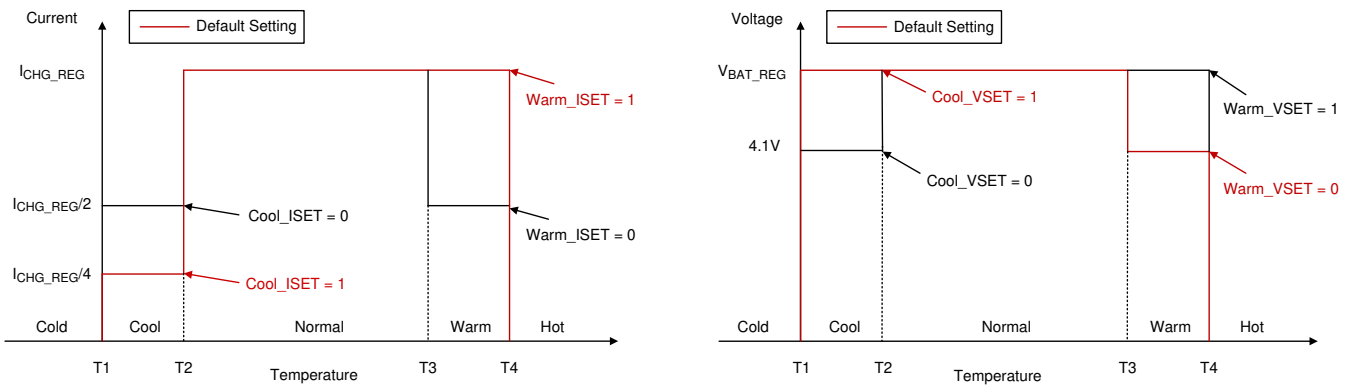

Figure 6. JEITA Protect for Charging Current and Voltage

There are four sections which are implemented for JEITA protection. Base on R<sub>HOT</sub> and R<sub>COLD</sub>, R<sub>T1</sub> and R<sub>T2</sub> can be calculated with equation (1) and (2). Herein, R<sub>HOT</sub> is the NTC resistance of battery over-temperature threshold, and R<sub>COLD</sub> is the NTC resistance of battery under-temperature threshold.

$$R_{T1} = V_{REGN} \times [(1/V_{T1} - 1/V_{T4}) / (1/R_{COLD} - 1/R_{HOT})] \dots\dots\dots(1)$$

$$R_{T2} = R_{T1} \times [1 / (V_{REGN} / V_{T1} - R_{T1} / R_{COLD} - 1)] \dots\dots\dots(2)$$

**• Thermal Protect During Boost Mode**

To start a boost mode to discharge from battery, the voltage on TS pin must be in T0 to T4 range. The device will stop converter if the battery temperature is lower than T0 (COLD\_OTG) or higher than T4 (HOT\_OTG). In this case, the IC\_STAT = 1000 for charge fault and an  $\overline{INT}$  is asserted to the host.

Once temperature returns to normal range, the boost mode is recovered.

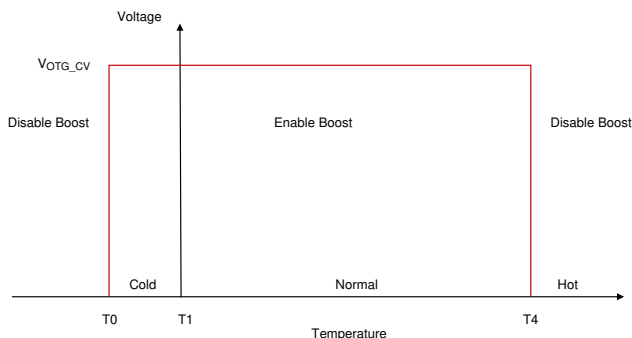

Figure 7. Thermal Protect During Boost Mode

**• Charging Safety Timer**

The device has safety timer to prevent abnormal charging time due to poor battery condition. The device can be set CHG\_SAFE\_TMR bits to change timer for fast charge cycle. When the safety timer expires, the device stops charging, the IC\_STAT = 1000 for charge fault, ST\_CHG\_TOUT = 1, and an  $\overline{INT}$  is asserted to the host. The safety timer can be disable by setting CHG\_SAFE\_TMR\_EN = 0.

**Table 6. Charging Safety Timer**

VBAT	Safety Timer
< V <sub>PRE_CHG</sub>	2 Hours
> V <sub>PRE_CHG</sub>	5 Hours, 10 Hours (Default), 15 Hours, 20 Hours

When the charger in AICR, MIVR, JEITA cool, JEITA warm or thermal regulation, the safety timer's counter clock rate will be half.

For example, if charger in AICR status, and timer setting is 10 hours, the actual safety timer will expire in 20 hours. The extended charge timer setting can be disabled by setting CHG\_SAFE\_TMR\_2XT = 0.

The safety timer will be reset by :

1. Toggle  $\overline{CE}$  pin
2. CHG\_EN disable/enable
3. CHG\_SAFE\_TMR disable/enable
4. REG\_RST is set.

• **MediaTek Pump Express+ (MTK, PE+)**

The device can provide an input current pulse to communicate with an MTK-PE+ high voltage adapter. When PE\_EN bit is enabled, the device can increase or decrease adapter output voltage by setting PE10\_INC to the desired value. After enabling PE function, the device will generate a VBUS current pattern for the MTK-PE+ adapter to automatically identify whether to increase or decrease output voltage. Once the PE pattern is finished, PE\_EN bit will clear to 0, and an INT is asserted to the host to indicate PE\_DONE.

• **Adaptive Input Current Control (AICC)**

The AICC function provides an adaptive AICR setting to prevent input voltage drops. When the input power source is over-current and the VBUS drops to the MIVR level, set AICC\_EN bit to 1, the device will automatically decrease AICR level step by step until exit MIVR event. Once AICC is finished, AICC\_EN bit will clear to 0, and an INT is asserted to the host to indicate AICC\_DONE.

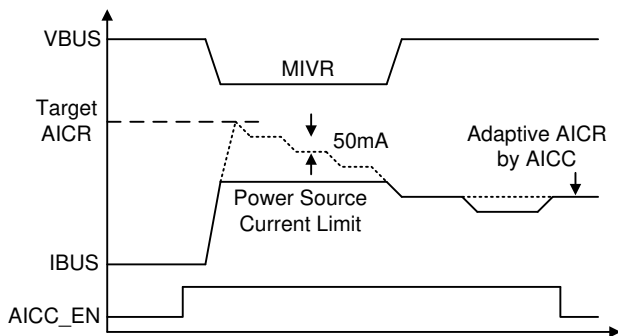

Figure 8. AICC Enable

**Status Outputs**

• **Power Good Indicator ( $\overline{\text{PG}}$  Pin and ST\_CHG\_RDY Bit)**

The  $\overline{\text{PG}}$  pin goes low to indicate a good power source when :

1. VBUS above VBUS\_MIN\_RISE, and IBADSRG is applied.
2. VBUS above VBAT (not in sleep mode)
3. VBUS below VAC\_OVP threshold setting
4. HZ = 0 (not in HZ mode)
5. The charger thermal is under THREG threshold setting
6. Completed VBUS Source Type Detection

• **Charging Status Indicator (STAT Pin)**

The device indicates IC\_STAT on STAT pin. The STAT pin is an open drain that can be used to drive LED. The STAT pin function can be disabled by setting the STAT\_EN = 0.

**Table 7. STAT Pin State**

IC_STAT	STAT Indicator
Trickle, Pre, Fast charge, IEOC-charge (EOC and TE = 0)	Low
Charge done, Back-Ground charge	High
HZ/SLEEP, VBUS ready for charge, OTG	High
Charge fault	Blinking at 1Hz



• **Interrupt to Host ( $\overline{\text{INT}}$  Pin)**

The device reports IRQ to host by the  $\overline{\text{INT}}$  pin, which is an open drain output.

The  $\overline{\text{INT}}$  pin generates a pulse low with 256 $\mu$ s when IRQ event occurs. All IRQ events are masked for default setting.

When a fault occurs, the device pulses an  $\overline{\text{INT}}$  to the host and keeps IRQ event in register 0x20 to 0x23 until the host reads the IRQ registers. Before the host reads IRQ registers to clean IRQ events, the device would not send any  $\overline{\text{INT}}$  pulse again unless any new event occurs.

**Table 8. STATUS, FLAG and MASK Register Map**

Name	STAT	IRQ	MASK
VBUS_GD	Y	Y	Y
CHG_RDY	Y	Y	Y
IEOC	Y	Y	Y
BK_CHG	Y	Y	Y
CHG_DONE	Y	Y	Y
RECHG	N	Y	Y
DETACH	N	Y	Y
BC12_DONE	Y	Y	Y
MIVR	Y	Y	Y
AICR	Y	Y	Y
CHG_THREG	Y	Y	Y
CHG_BUSUV	Y	Y	Y
CHG_TOUT	Y	Y	Y
CHG_SYSOV	Y	Y	Y
CHG_BATOV	Y	Y	Y
JEITA_HOT	Y	Y	Y
JEITA_WARM	Y	Y	Y
JEITA_COOL	Y	Y	Y
JEITA_COLD	Y	Y	Y
SYS_MIN	Y	Y	Y
SYS_SHORT	N	Y	Y
OTP	Y	Y	Y
VAC_OV	Y	Y	Y
WDT	Y	Y	Y
OTG_CC	Y	Y	Y
OTG_LBP	N	Y	Y
OTG_FAULT	N	Y	Y



## Protections

### • VBUS Over-Voltage Protection in Buck Mode

If VBUS voltage over VAC\_OVP setting (programmable by VAC\_OVP bits), the device stops switching immediately and an  $\overline{\text{INT}}$  pulse is asserted to the host. When VBUS overvoltage, the status ST\_VAC\_OV = 1 and the IC\_STAT = 1000 for charge fault. The device resume to normal operation when VBUS voltage drops below the VAC\_OVP threshold.

### • VBUS Over-Voltage Protection in Boost Mode

When boost mode, VAC\_OVP setting is locked at 6.5V even if VAC\_OVP threshold is set at 10.5V or 14V. When the output voltage (VBUS) exceeds VAC\_OVP threshold, the device stops switching immediately, clear OTG\_EN bit to 0 and exit boost mode. The fault (OTG\_FAULT) is set to high and an  $\overline{\text{INT}}$  pulse is asserted to the host to indicate in boost mode. When the output voltage falling VAC\_OVP\_HYS below VAC\_OVP threshold, the OTG\_EN bit can be set to 1 by the host.

### • IBUS Overload Protection in Boost Mode

The device monitors boost output voltage and current to provide VBUS short circuit protection. The device also builds in constant current regulation to allow OTG to adaptive to various types of load. If short circuit is detected on VBUS, the boost will hiccup 7 times. If boost retries are not successful, OTG\_EN bit will set to 0 to disable boost mode and INT pulse is asserted to the host to indicate OTG\_FAULT.

### • VBUS Soft-Start

When the boost function is enabled, the device soft-starts on VBUS to avoid inrush current.

### • VSYS Over-Voltage Protection

YSOVP threshold is set at 5.2V. Once VSYS is above YSOVP level, buck stops switching immediately and an  $\overline{\text{INT}}$  pulse is asserted to host to indicate CHG\_SYSOV fault. The device provides 30mA current sink on VSYS to bring down the VSYS voltage.

### • VSYS Over-Current Protection

When the system is shorted or overloaded ( $I_{\text{BAT}} > I_{\text{OCP\_BATFET}}$ ), the device latches off BATFET (forces enter shipping mode) and an  $\overline{\text{INT}}$  pulse is asserted to host to indicate SYS\_SHORT fault. Exit shipping mode can reset the latch-off condition and turn on BATFET.

### • Battery Over-Voltage Protection

The BAT\_OVP threshold is 4% above the VBAT\_REG setting. When battery exceeds overvoltage threshold, the device disables charging immediately and an  $\overline{\text{INT}}$  is asserted to the host to indicate CHG\_BATOV.

### • Battery Over-Discharge Protection

When battery is discharged below VBAT\_DPL\_FALL, the BATFET turns off to protect battery over discharged. When VBUS is plugged in, the BAFET turns on to charge battery.

### • Thermal Protection in Buck Mode

The device monitors the internal junction temperature to avoid overheat. When in buck mode, the thermal regulation threshold is set at 120°C (programmable by register THREG bits). When junction temperature exceeds thermal regulation threshold, the device decreases the charge current. During thermal regulation, EOC function is disabled, the safety timer's counter clock rate will be half and an  $\overline{\text{INT}}$  is asserted to the host indicate CHG\_THREG.

In addition, the device has thermal shutdown to turn off the converter when the IC surface temperature exceeds TOTP (160°C) and an  $\overline{\text{INT}}$  is asserted to the host indicate OTP fault. The converter is recovered when the surface temperature is below TOTP (160°C) - TOTP\_HYS (30°C).

### • Thermal Protection in Boost Mode

The device has thermal shutdown during boost mode. In boost mode, when the IC surface temperature exceeds TOTP (160°C), the OTG\_EN bit is set to 0 to disable boost mode and an  $\overline{\text{INT}}$  is asserted to the host indicate OTP fault. When the surface temperature is below TOTP (160°C) - TOTP\_HYS (30°C), the host can re-enable boost mode by setting OTG\_EN bit to 1.

**Communicate Interface**

The RT9470 use I<sup>2</sup>C compatible interface by 2-wire line (SCL and SDA) to communicate with the host. The SCL and SDA pins are open drain which needs to connect to supply voltage by pull-up resistors. The RT9470 operates as an I<sup>2</sup>C slave device with 7-bits address 53H, supports up to 3.4Mbits conditionally. To start an

I<sup>2</sup>C communication, beginning with START (S) condition, and then the host sends slave address. This address is 7-bits long followed by an eighth bits which is a data direction bit (R/W). The second bytes is register address. The third bytes contains data to the selected register. End with STOP (P) condition.

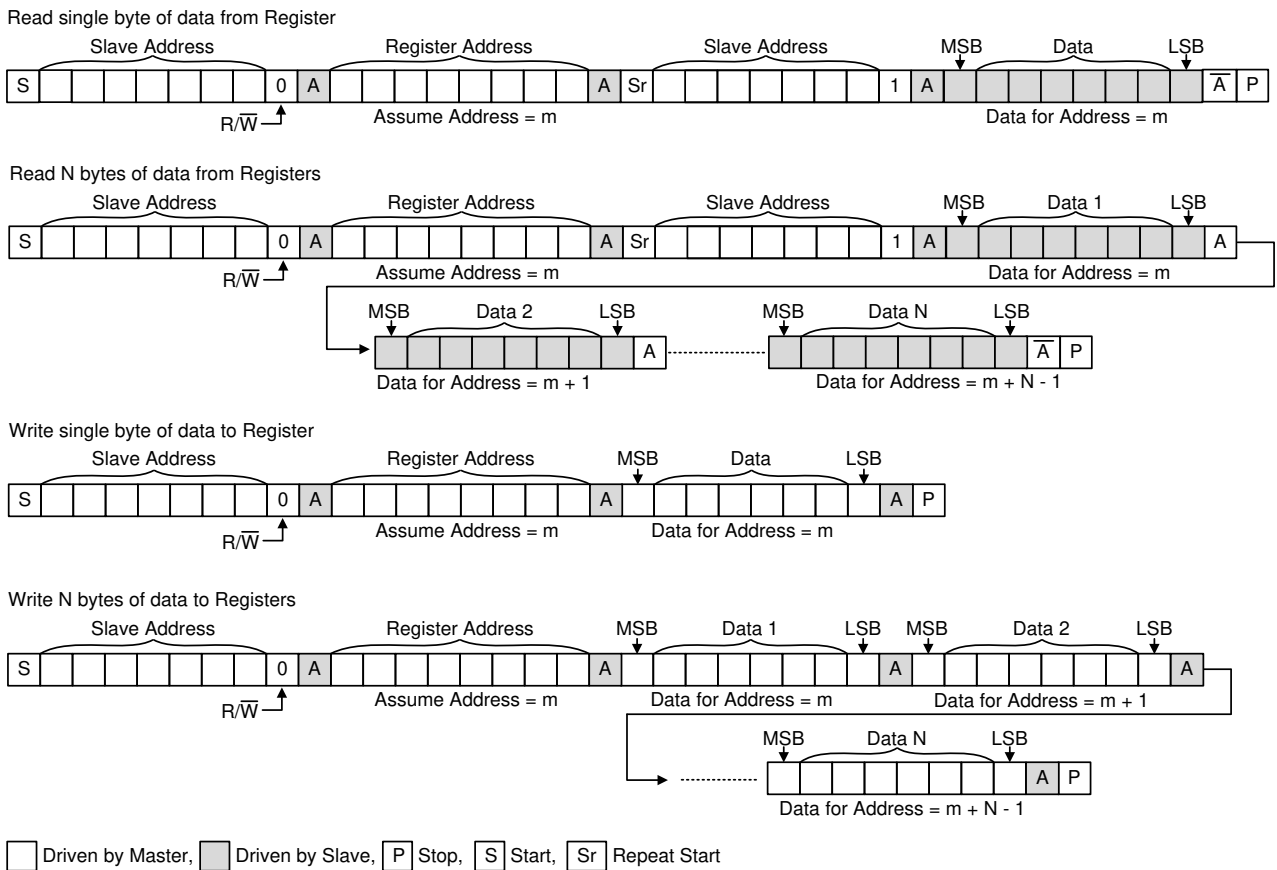

Figure 9. Read and Write Function

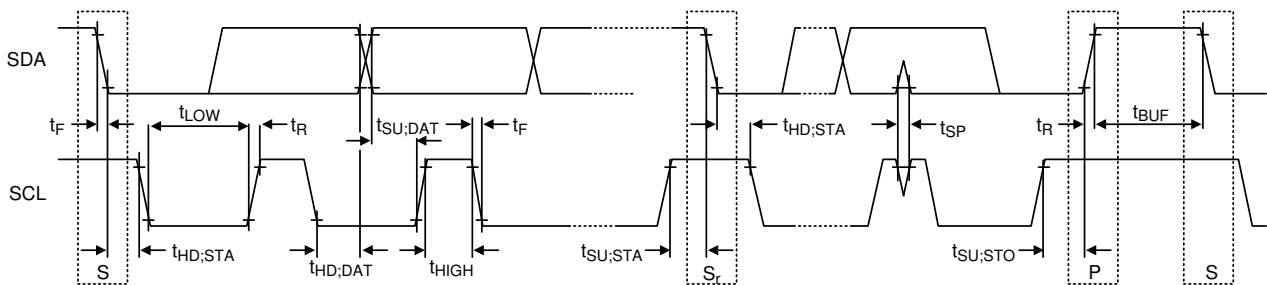

Figure 10. I<sup>2</sup>C Waveform Information

• **I<sup>2</sup>C Time-out Reset**

To avoid I<sup>2</sup>C hang-ups, a timer runs during I<sup>2</sup>C activity. If the SDA keep low longer than 1 second,

the RT9470 will reset I<sup>2</sup>C to release SDA goes back to High. The I<sup>2</sup>C hang-ups reset function can be disable by register 0x01[3] bit.

**Thermal Considerations**

The junction temperature should never exceed the absolute maximum junction temperature  $T_{J(MAX)}$ , listed under Absolute Maximum Ratings, to avoid permanent damage to the device. The maximum allowable power dissipation depends on the thermal resistance of the IC package, the PCB layout, the rate of surrounding airflow, and the difference between the junction and ambient temperatures. The maximum power dissipation can be calculated using the following formula :

$$P_{D(MAX)} = (T_{J(MAX)} - T_A) / \theta_{JA}$$

where  $T_{J(MAX)}$  is the maximum junction temperature,  $T_A$  is the ambient temperature, and  $\theta_{JA}$  is the junction-to-ambient thermal resistance.

For continuous operation, the maximum operating junction temperature indicated under Recommended Operating Conditions is 150°C. The junction-to-ambient thermal resistance,  $\theta_{JA}$ , is highly package dependent. For a WL-CSP-30B 2.1x2.5 (BSC) package, the thermal resistance,  $\theta_{JA}$ , is 29.6°C/W on a standard JEDEC 51-7 high effective-thermal-conductivity four-layer test board. The maximum power dissipation at  $T_A = 25^\circ\text{C}$  can be calculated as below :

$$P_{D(MAX)} = (150^\circ\text{C} - 25^\circ\text{C}) / (29.6^\circ\text{C/W}) = 4.22\text{W for a WL-CSP-30B 2.1x2.5 (BSC) package.}$$

The maximum power dissipation depends on the operating ambient temperature for the fixed  $T_{J(MAX)}$  and the thermal resistance,  $\theta_{JA}$ . The derating curves in Figure 11 allows the designer to see the effect of rising ambient temperature on the maximum power dissipation.

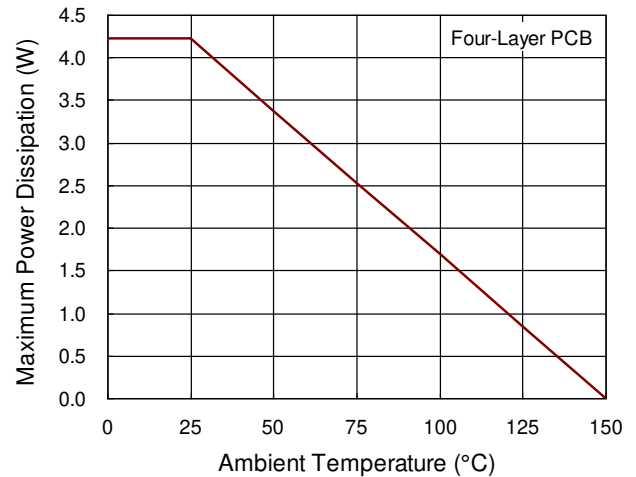

Figure 11. Derating Curve of Maximum Power Dissipation

## Layout Considerations

The RT9470/D layout guidelines are shown as below, there are several suggestions provided.

- ▶ The capacitor, connected to PMID pin needs to be placed as close as possible to the RT9470/D.
- ▶ The inductor, connected to SW pin needs to not only router the trace as short as possible to reduce the EMI but also make sure copper area of the trace is enough for the operating current.

- ▶ The capacitors, connected to IC pins need to be placed as close as possible to the RT9470/D.
- ▶ The VBUS needs to router two layers power plane to reduce resistance.
- ▶ The SYS needs to router two layers power plane to reduce resistance. Otherwise, the accuracy of ICHG will be affected.

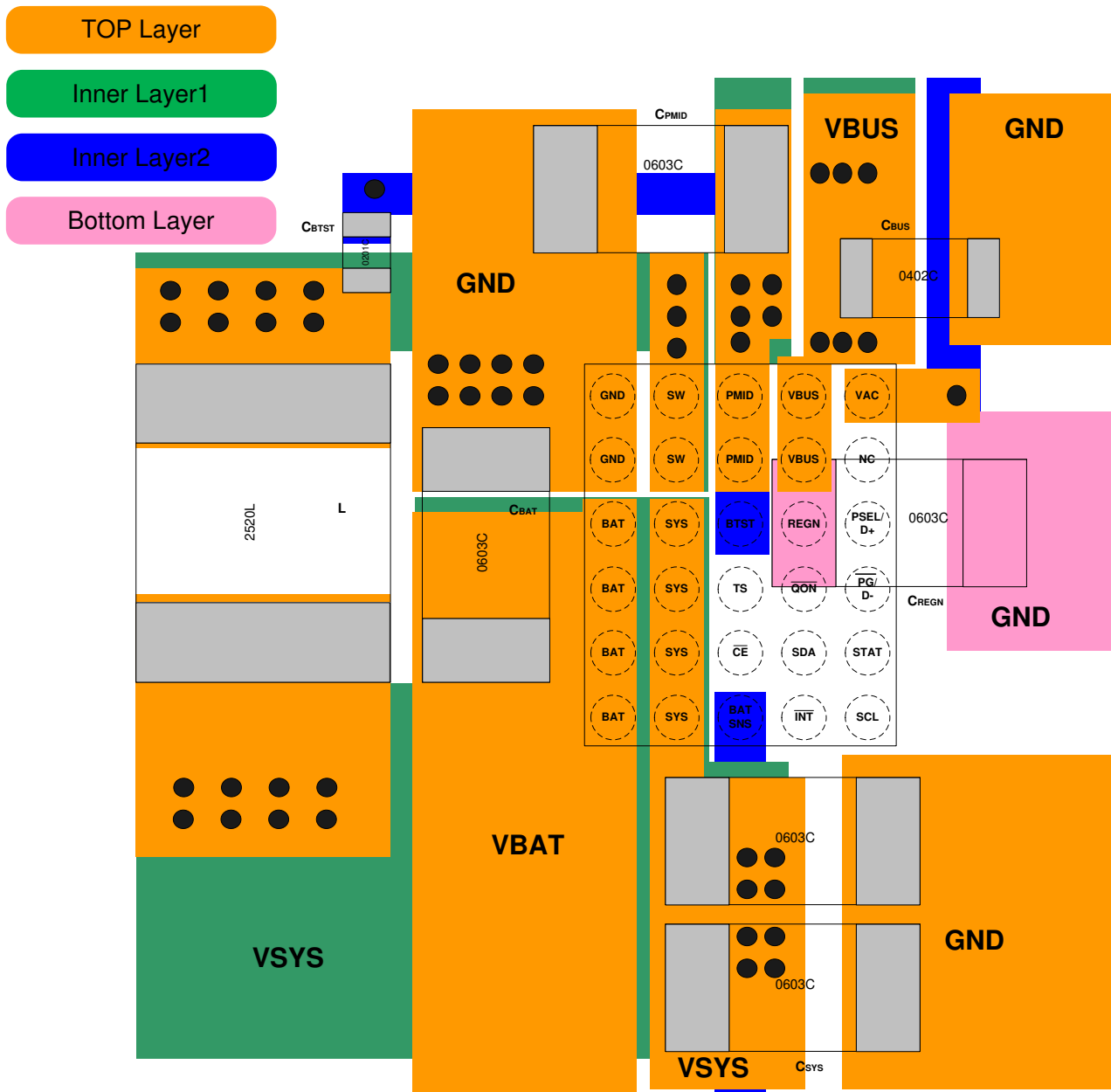
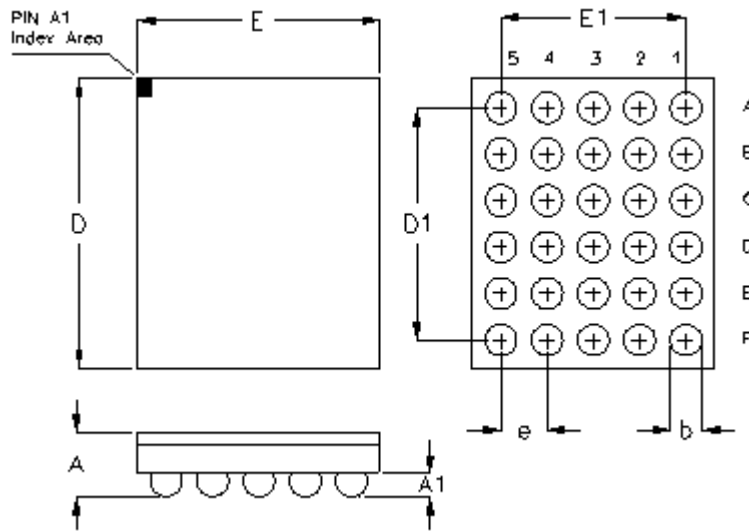

Figure 12. PCB Layout Guide

**Outline Dimension**



Symbol	Dimensions In Millimeters		Dimensions In Inches	
	Min	Max	Min	Max
A	0.500	0.600	0.020	0.024
A1	0.170	0.230	0.007	0.009
b	0.240	0.300	0.009	0.012
D	2.460	2.540	0.097	0.100
D1	2.000		0.079	0.000
E	2.060	2.140	0.081	0.084
E1	1.600		0.063	0.000
e	0.400		0.016	

**30B WL-CSP 2.1x2.5 Package (BSC)**

## Footprint Information

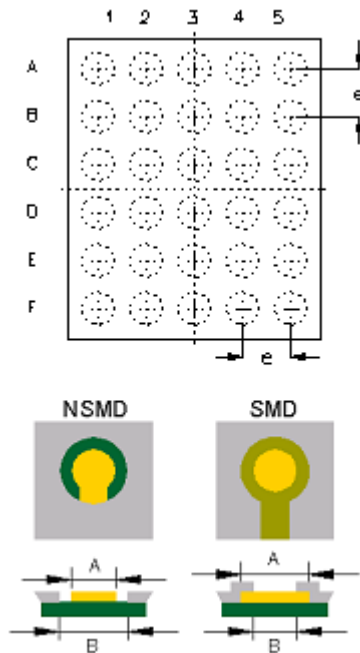

Package	Number of Pin	Type	Footprint Dimension (mm)			Tolerance
			e	A	B	
WL-CSP2.1x2.5-30(BSC)	30	NSMD	0.400	0.240	0.340	±0.025
		SMD		0.270	0.240	

### Richtek Technology Corporation

14F, No. 8, Tai Yuen 1<sup>st</sup> Street, Chupei City  
 Hsinchu, Taiwan, R.O.C.  
 Tel: (8863)5526789

Richtek products are sold by description only. Richtek reserves the right to change the circuitry and/or specifications without notice at any time. Customers should obtain the latest relevant information and data sheets before placing orders and should verify that such information is current and complete. Richtek cannot assume responsibility for use of any circuitry other than circuitry entirely embodied in a Richtek product. Information furnished by Richtek is believed to be accurate and reliable. However, no responsibility is assumed by Richtek or its subsidiaries for its use; nor for any infringements of patents or other rights of third parties which may result from its use. No license is granted by implication or otherwise under any patent or patent rights of Richtek or its subsidiaries.