

THIS DRAWING IS UNPUBLISHED. RELEASED FOR PUBLICATION
 © COPYRIGHT - TE Connectivity ALL RIGHTS RESERVED.

REVISIONS				
P	LTR	DESCRIPTION	DATE	APVD
P	ECR-16-013249		07JUL2017	FL SY

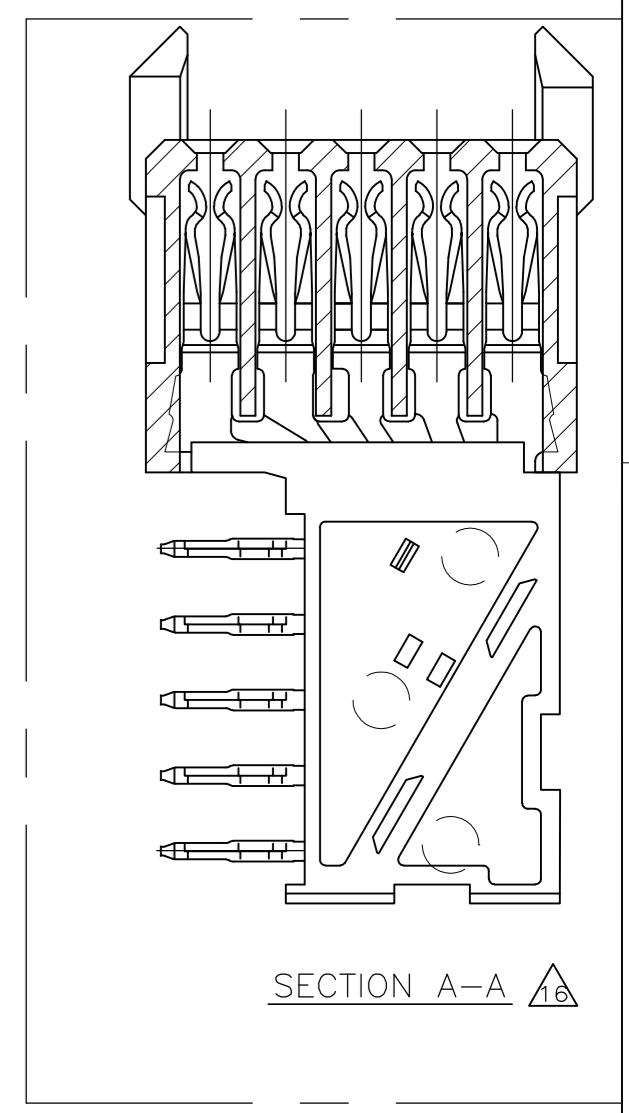

- NOTES:
- 1 MATERIAL HOUSING : GREY GLASSFILLED POLYESTER. MATERIAL CONTACTS: PHOSPHORBRONZE.
 - 2 GENERAL PLATING SPECIFICATION: UNDERPLATING (ENTIRE CONTACT): 1,27µm NICKEL MIN. AND ACTION PIN: 0,5µm TIN-LEAD MIN. FOR PLATING OF MATING SURFACES SEE APPLICABLE SPECIFICATION REFERENCE FOR EACH DASH NUMBER.
 - 3 CONFORMS TO ALL TESTING ACCORDING IEC 61076-4-101 PERFORMANCE LEVEL 2.
 - 4 CONFORMS TO ALL TESTING ACCORDING IEC 61076-4-101 PERFORMANCE LEVEL 1.
 - 5 CONNECTOR TESTED AND QUALIFIED AGAINST TELCORDIA GR-1217-CORE QUALITY LEVEL III, CENTRAL OFFICE APPLICATIONS.
 - 6 CONNECTOR TESTED AND QUALIFIED AGAINST TELCORDIA GR-1217-CORE QUALITY LEVEL III, UNCONTROLLED ENVIRONMENT APPLICATIONS.
 - 7 CONNECTOR LUBRICATED WITH TELCORDIA GR-1217-CORE APPROVED LUBRICANT.
 - 8 CONTACT CAVITIES (3x) SUITABLE FOR 4,8 DIA. HIGH CURRENT, HIGH FREQUENCY OR FIBRE OPTIC CONTACTS AS PER DIN 41626 (SEE ALSO NOTE 12).
 - 9 CONNECTOR PRINTED WITH PARTNUMBER AND DATECODE. THE MARKING CAN APPEAR ON THE FRONT SIDE OR ON THE BACK SIDE.
 - 10 AREA RESERVED FOR KEYING PART, BASIC P/N 100526.
 - 11 PLATED-THROUGH HOLES AT 2x2mm SQUARE GRID (55 HOLES).
 - 12 1,3 DIA. PLATED-THROUGH HOLES (15x) CAN BE OMITTED IF SPECIAL CONTACTS WITH CABLE CONNECTION OR FIBRE OPTIC CONTACTS ARE USED.
 - 13 THIS ROW OF 11 CAVITIES (B1 TO B11) FOR CONNECTOR ASSEMBLY PURPOSE ONLY. NOT PLATED-THROUGH HOLES (3x).
 - 15 FITS WITH INTEGRATED GROUND RETURN UPPERSHIELD, BASIC P.N. 352111 AND INTEGRATED GROUND RETURN LOWERSHIELD, BASIC P.N. 352112
 - 16 CONNECTOR ASSEMBLED WITH REDESIGNED CONTACTS. CONTACTS HAVE A CORING-OUT IN THE PLASTIC.
 - 17 OBSOLETE PARTS: OBSOLETE CIS STREAMLINING PER D.RENAUD/D.SINISI
 - 18 0,76µm MIN GOLD PLATING AT MATING SURFACES.

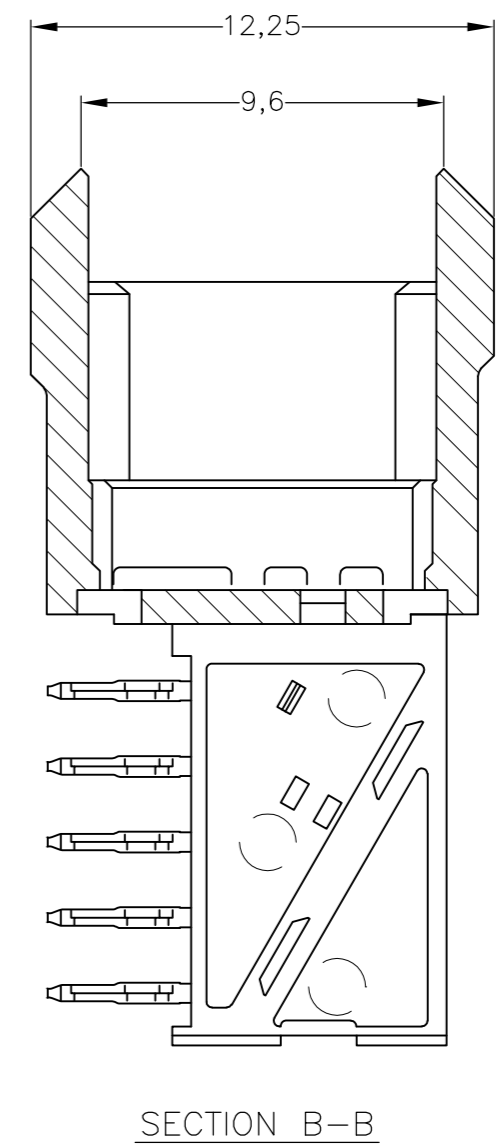
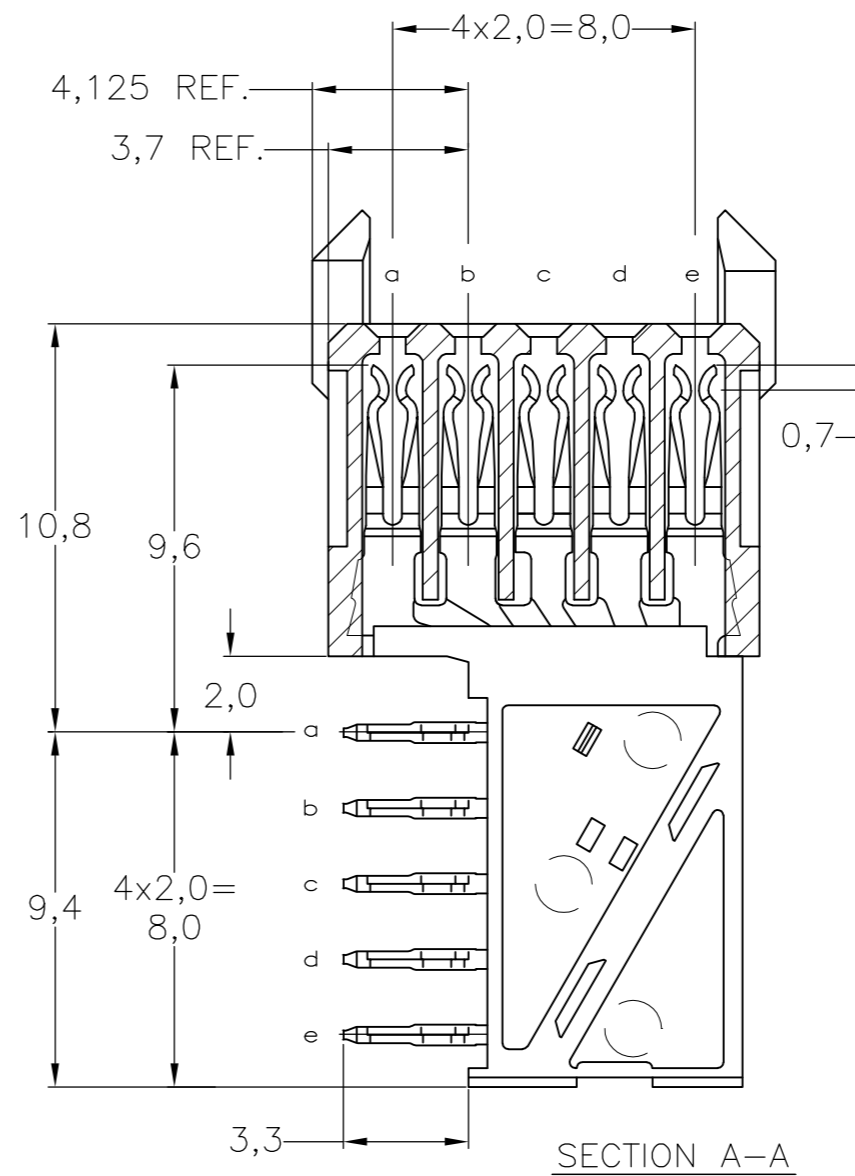
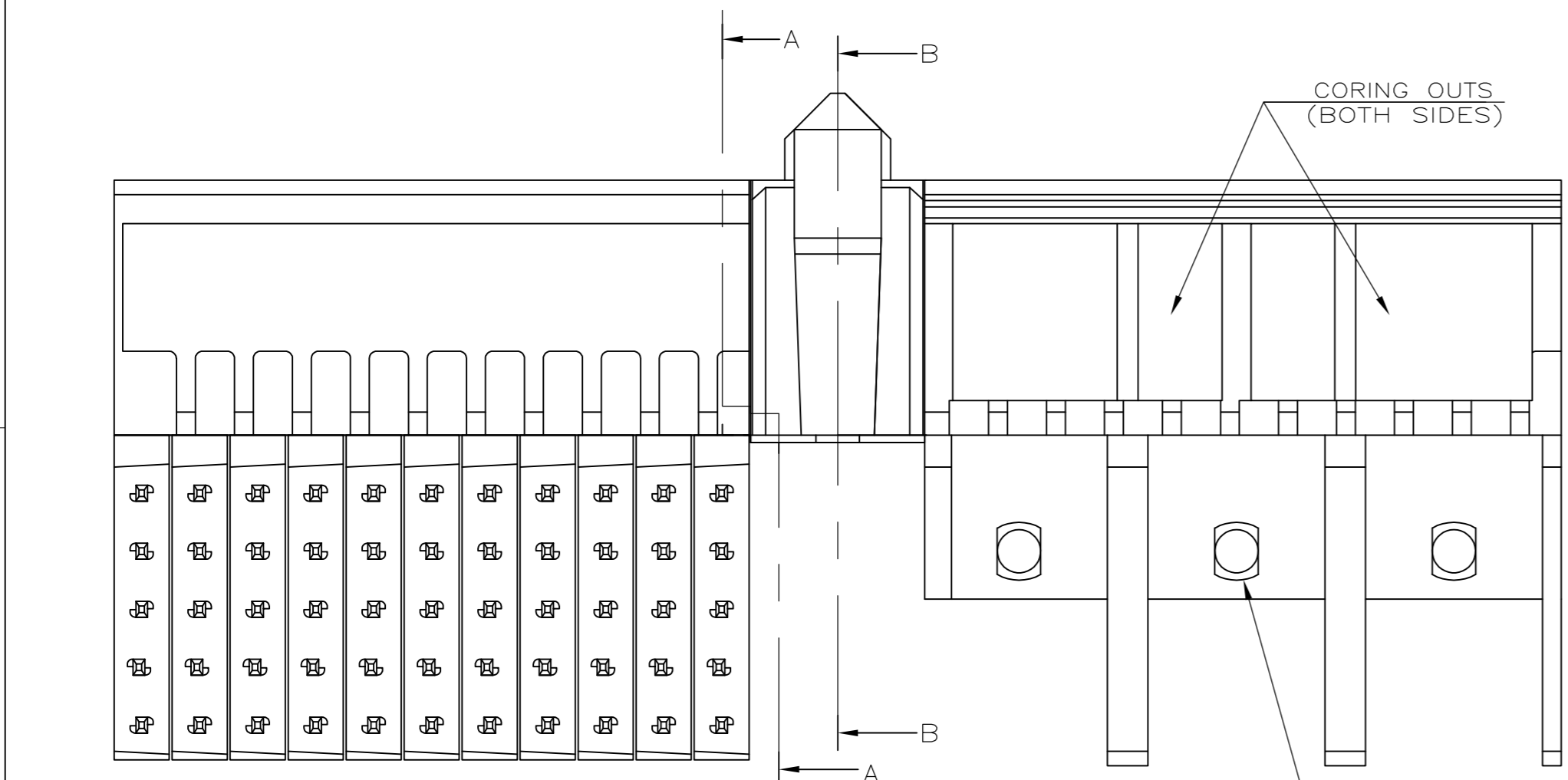
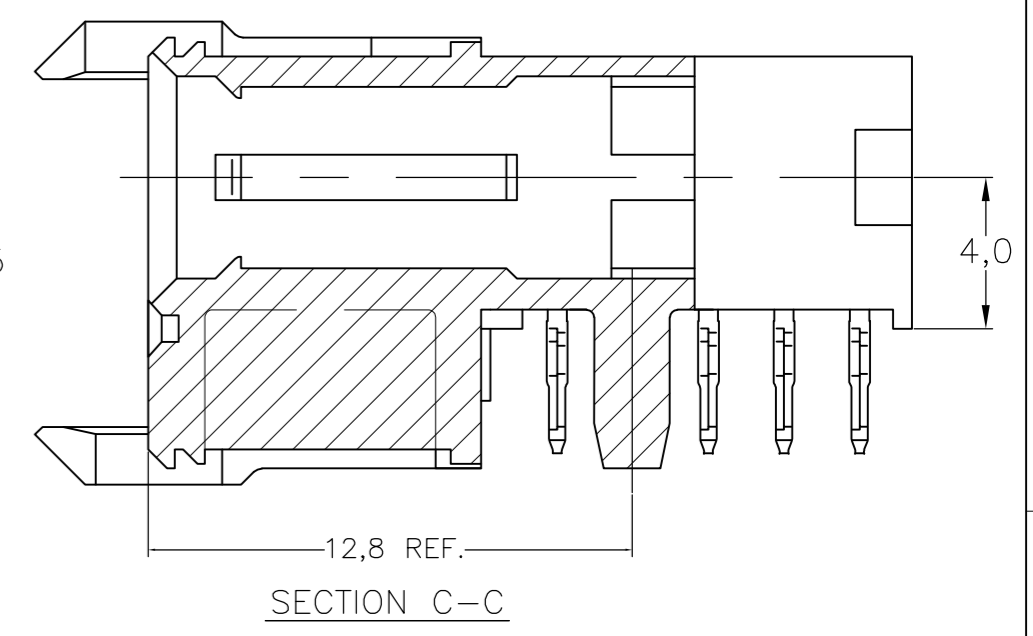
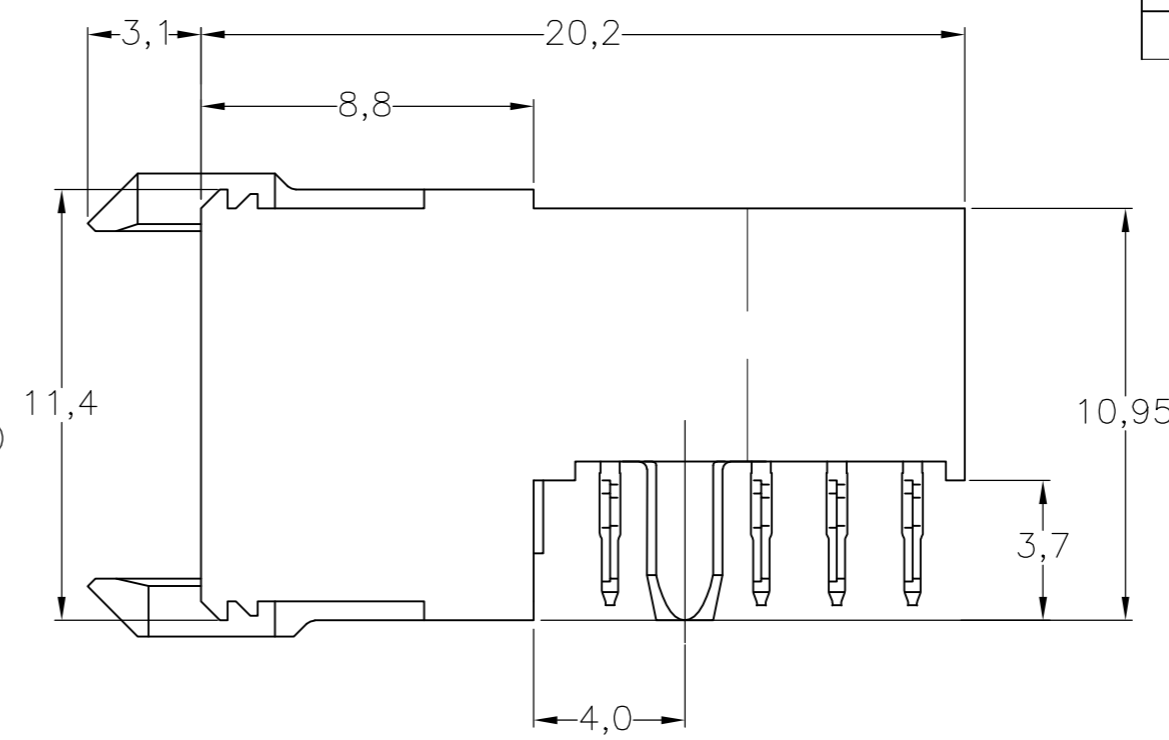
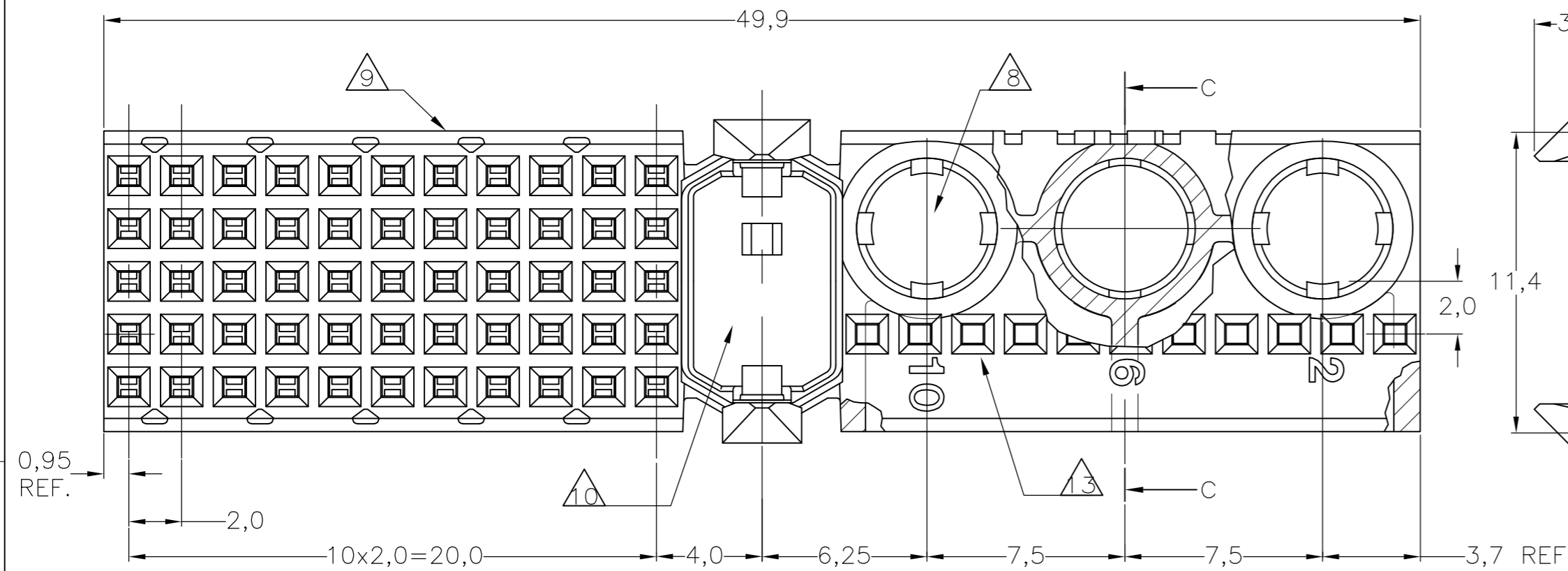
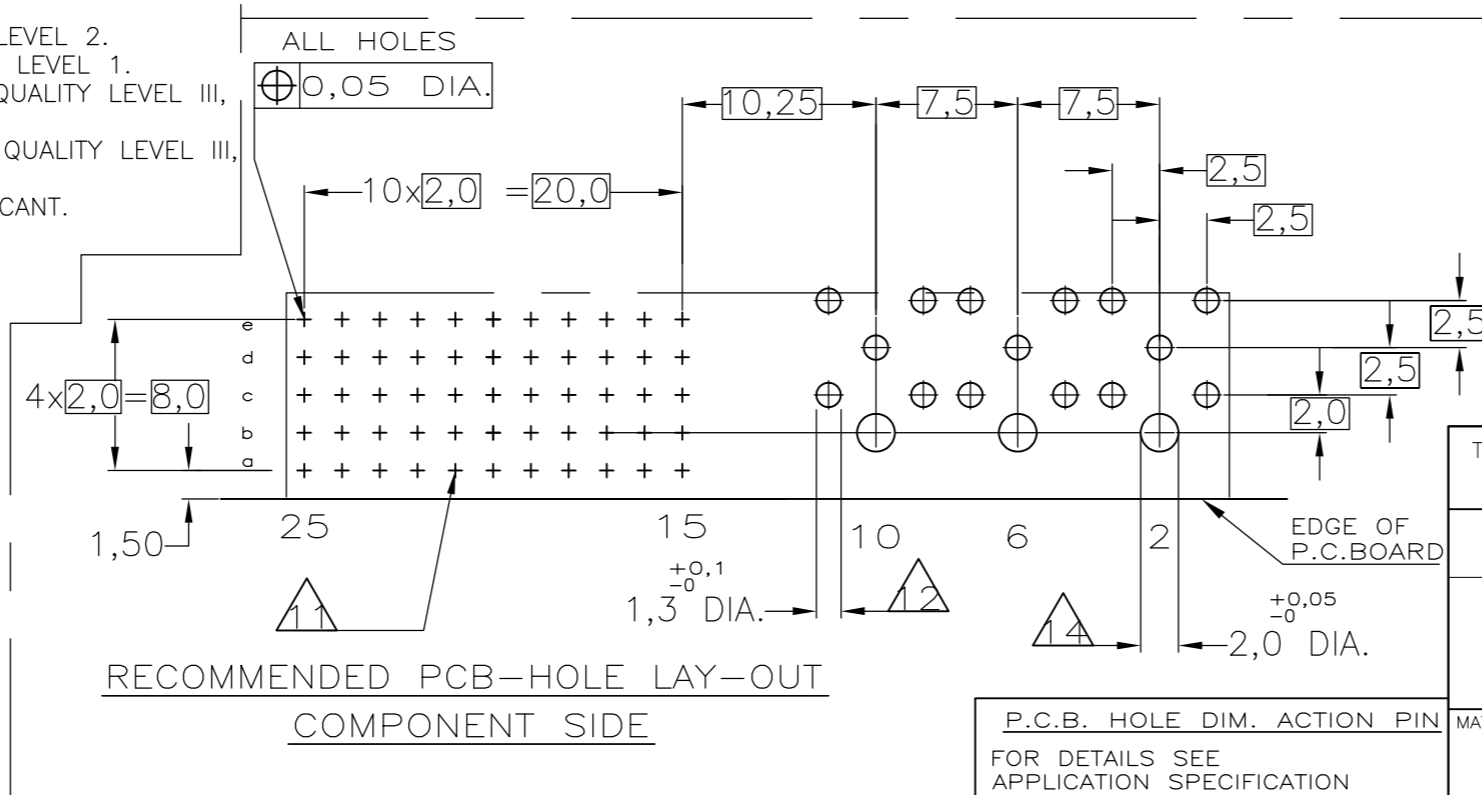

	FINISH	MATERIAL	PARTNUMBER
OBSOLETE	2 3 18	1	3-100750-0
OBSOLETE	2 6 18	1	1-100750-9
OBSOLETE	2 5 18	1	100750-9
OBSOLETE	2 4 18	1	100750-4
OBSOLETE	2 3 18	1	100750-1

THIS DRAWING IS A CONTROLLED DOCUMENT.

DWN	D.TRUREN	20JAN97
CHK	W.V.D.HEIJDEN	20JAN97
APVD	B. MOOIJ	
PRODUCT SPEC	108-19082	
APPLICATION SPEC	114-19029	
WEIGHT	0.000000	
CUSTOMER DRAWING		

TE Connectivity

Z-PACK 2MM HM
TYPE M FEMALE CONNECTOR

SIZE	A2	CAGE CODE	00779	DRAWING NO	C=100750	RESTRICTED TO	-
SCALE	NTS	SHEET	1 of 1	REV	P		