

MATERIALS AND FINISHES

BODY, JAM NUT: BRASS
PLATED NICKEL

LOCK WASHER: PHOSPHOR BRONZE
PLATED NICKEL

DIELECTRIC: POLY-BUTYLENE TEREPHTHALATE (WHITE)

CONTACT: PHOSPHOR BRONZE
PLATED GOLD

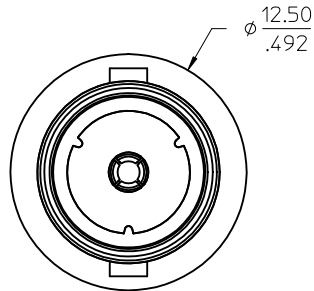

75 OHM
INTERFACE

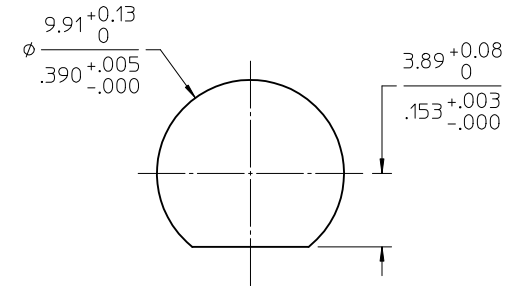
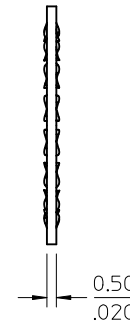
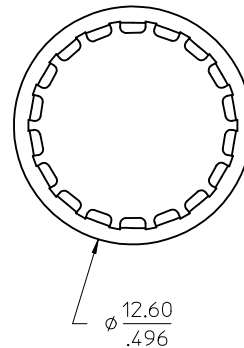
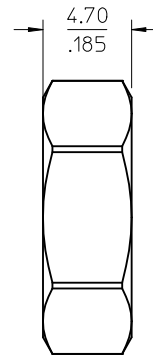
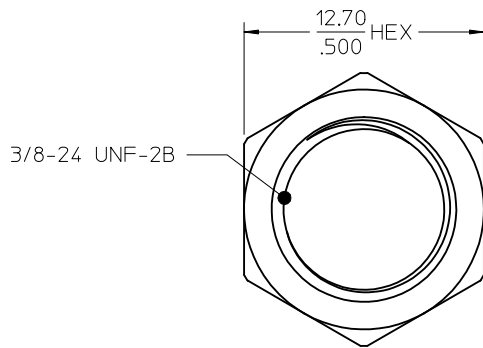
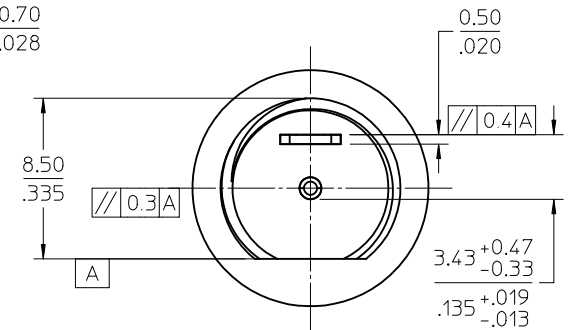
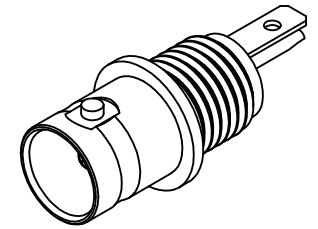
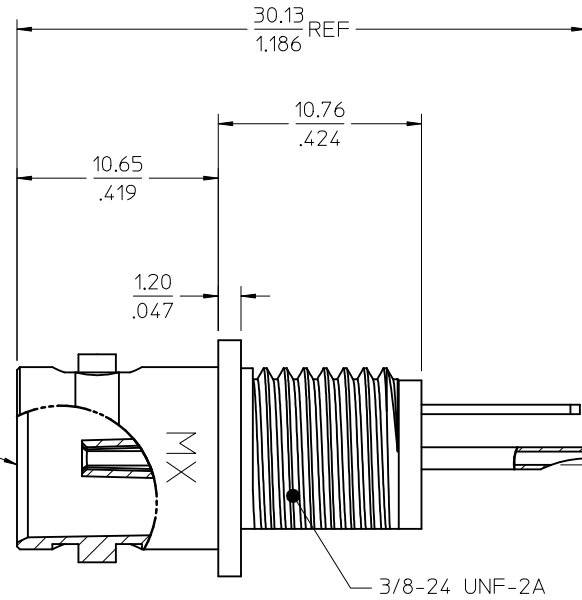

PANEL CUTOUT
MAXIMUM THICKNESS: 2.66mm
MOUNTING TORQUE: 4.5 IN-LBS MAX

PART # 73115-7053
PACKAGING: BULK

PS-89675-1030	PRODUCT SPECIFICATION
SPECIFICATION	DESCRIPTION

ORIGINALLY DRAWN BY IRIS W. 1992/02/19

CHG: REDREW IN 3D AND RECREATED DRAWING. EC NO: URF2012-0006 DRAWN: AROBERTSON 2011/07/08 CHKD: SSS 2011/07/08 APPR: JWIENER 2011/07/08 REV: B1	QUALITY SYMBOLS ▽=0 ▽=0	GENERAL TOLERANCES (UNLESS SPECIFIED) <table border="1"> <tr> <th></th> <th>mm</th> <th>INCH</th> </tr> <tr> <td>4 PLACES</td> <td>± .005</td> <td>± .0002</td> </tr> <tr> <td>3 PLACES</td> <td>± .003</td> <td>± .0001</td> </tr> <tr> <td>2 PLACES</td> <td>± .002</td> <td>± .00005</td> </tr> <tr> <td>1 PLACE</td> <td>± .001</td> <td>± .00002</td> </tr> </table> ANGULAR ± 2°		mm	INCH	4 PLACES	± .005	± .0002	3 PLACES	± .003	± .0001	2 PLACES	± .002	± .00005	1 PLACE	± .001	± .00002	DIMENSION STYLE MM/IN	SCALE METRIC	DESIGN UNITS METRIC	THIRD ANGLE PROJECTION
		mm	INCH																		
	4 PLACES	± .005	± .0002																		
	3 PLACES	± .003	± .0001																		
2 PLACES	± .002	± .00005																			
1 PLACE	± .001	± .00002																			
DRAWN BY AROBERTSON	DATE 2011/07/08	TITLE BNC JACK BLKHD FM RCPT 75 OHM SOLDER LUG BNC-JR, EWR-4739	MATERIAL NO. 731157053	DOCUMENT NO. SD-73115-7053	SHEET NO. 1 OF 1																
DRAFT WHERE APPLICABLE MUST REMAIN WITHIN DIMENSIONS																					
THIS DRAWING CONTAINS INFORMATION THAT IS PROPRIETARY TO MOLEX INCORPORATED AND SHOULD NOT BE USED WITHOUT WRITTEN PERMISSION																					