

## Overview

KEMET's QGS thin film digital pyroelectric IR sensors for gas detection and concentration measurement combine high sensitivity with fast response times and high dynamic range to ensure rapid and accurate detection of target gases.

These high quality sensors, in their small SMD package, integrate a digital, current mode read-out that enables lower IR-emitter duty cycles, thereby saving significantly on system level power consumption, while maintaining high SNR. Industry standard I<sup>2</sup>C communication enables plug-and-play connectivity to microcontrollers and allows easy tuning and calibration. Programmable gain and filtering offer maximum flexibility in system design, and various optical filter options are also available. These sensors can be connected together in linear series to allow synchronized sampling across devices.

Their long and maintenance-free operational lifetime makes them ideal for highly demanding automotive or medical applications.

For additional sources of information, please refer to the [Environmental Sensors page on KEMET.com](#)

## Benefits

- High sensitivity with fast response time
- High dynamic range
- Small SMD package
- I<sup>2</sup>C communication
- Digital output
- Programmable gain and filtering
- Various optical filter options
- Integrated configurable amplifier, filter and ADC
- Low power consumption
- Sensor modules and digital evaluation kit available for easy evaluation and quick prototype development (ref QGSM Series)

## Applications

- Gas and gas flues
- HVAC (refrigerant or CO<sub>2</sub>-driven ventilation system)
- Industrial process and safety
- Medical capnography and anesthesia
- Handheld breath analysis and breath rate measurement
- Breath actuated dispenser
- Automotive cabin air quality
- Exhaust (CO<sub>2</sub> content)
- Home and building technology
- Environmental monitoring (ambient CO<sub>2</sub> level)
- Pollution air quality in home, office and car (excessive CO<sub>2</sub> level)

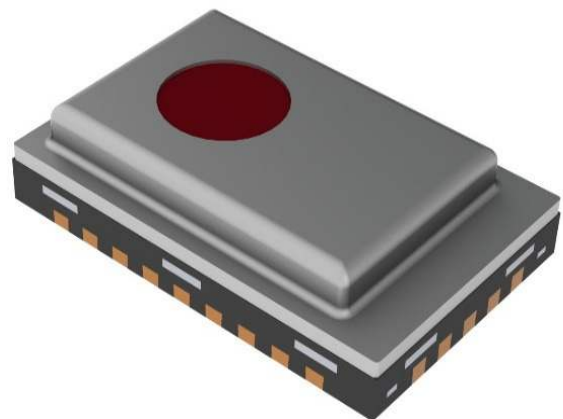

## Ordering Information

USE	QGS	E	A	C821	8	0
Product Family	Series	Sensor Type	Mounting Type	Specification	Packaging	Version
Sensors	QGS = SMD IR Gas Sensors	E = Serial output	A = Sensor only, low profile H = Sensor only, high profile	C821 = CO <sub>2</sub> CH41 = CH <sub>4</sub> N8L1 = NO 9501 = 9.50 μm	8 = 7" Tape & Reel	0

## Environmental Compliance

All KEMET Gas Sensors are RoHS and REACH Compliant.



Article 33(1) of the REACH Regulation states that manufacturers and importers of articles (products) are required to notify their customers of the presence of any Substances of Very High Concern (SVHC) in their products exceeding 0.1% by weight and provide instructions on safe use of the product.

KEMET Corporation reports regarding the Article 33(1) of REACH Regulation as follows:

1. *Applicable Product: Gas Sensors (QGC, QGS & QGSM series)*

2. *Report for the content of REACH SVHC list:*

*The product(s) above contains a substance by more than 0.1wt% per product weight that was published in the 8th update of the REACH SVHC substances (December 19, 2012).*

3. *Regarding the safety of the gas sensors (Piezoceramic products):*

*The Piezoceramic that is used in this product becomes ceramic by sintering powder containing PZT as the main ingredient. It is chemically stable, with minimum risks toward the human body or environment within the intended use of the product. Please note that risks could occur in the case of inhalation or accidental oral uptake of powder ceramics.*

4. *Technical product information on the gas sensors (Piezoceramic products):*

*The manufacturing technique of the "piezoceramic products" whose main ingredient is Lead Titanium Zirconium Oxide (PZT) has been established, and there is no alternative material that can exhibit superior performance than PZT at this moment. Please note that the piezoceramic is listed as an exempt on RoHS (2011/65/EU) AnnexIII (7c.1).*

5. *The responsibility of piezoceramic manufacturers:*

*Piezoceramic manufacturers report information regarding PZT containment in their products to the customers to obey the article 33 of the REACH regulation.*

## Infrared Spectroscopy

KEMET Infrared Sensors work in the MID Infrared Spectrum. They are a critical component -- but not the only component -- in a gas analysis system. An IR heat source and a suitable gas path “mechanical enclosure” are also required in order to complete the gas analysis system.

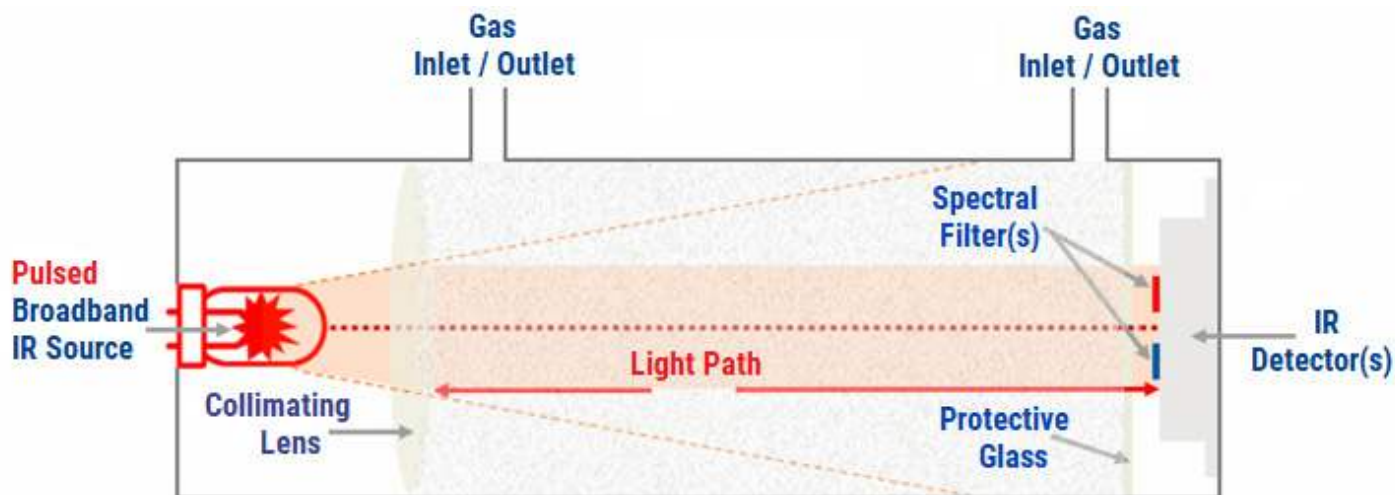

## IR Absorption - Active IR Sensing

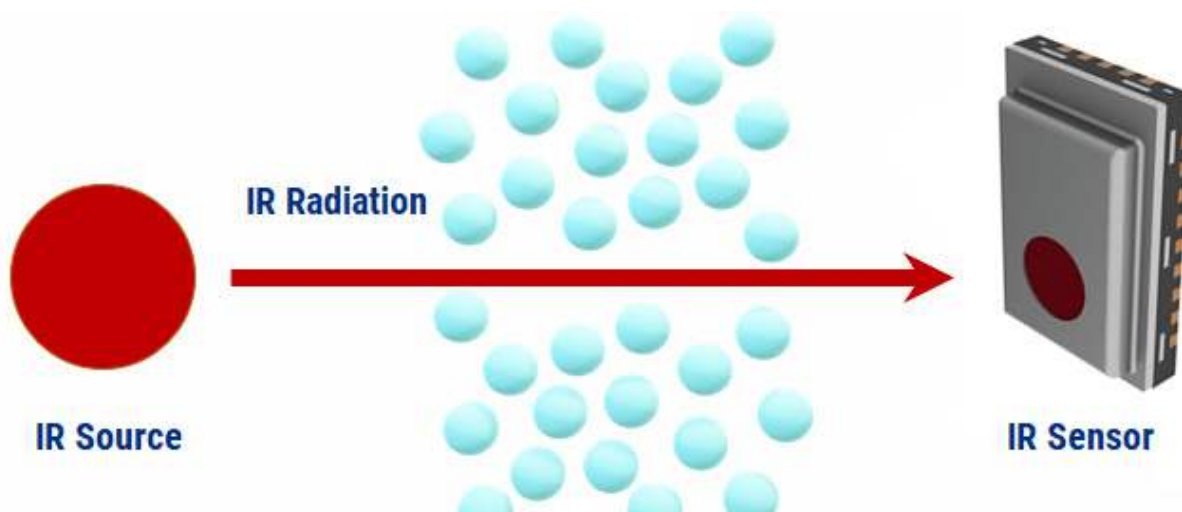

The IR source is directed as energy towards the sensor like an IR spotlight. Depending on the specific gas of interest or gas concentration levels between the IR source and the pyroelectric sensor, the IR transmitted is absorbed by the presence of the gas by a small amount. Understanding how much IR is being optically transmitted versus how much is received can indicate gas concentration levels.

Filters are used to shorten the optical spectrum of the sensor to specifically match the gas of interest. These filters are usually included within the sensor, but for special cases KEMET can make optimised filters to suit customers specific gas requirements.

## Dimensions – Millimeters

### Sensor

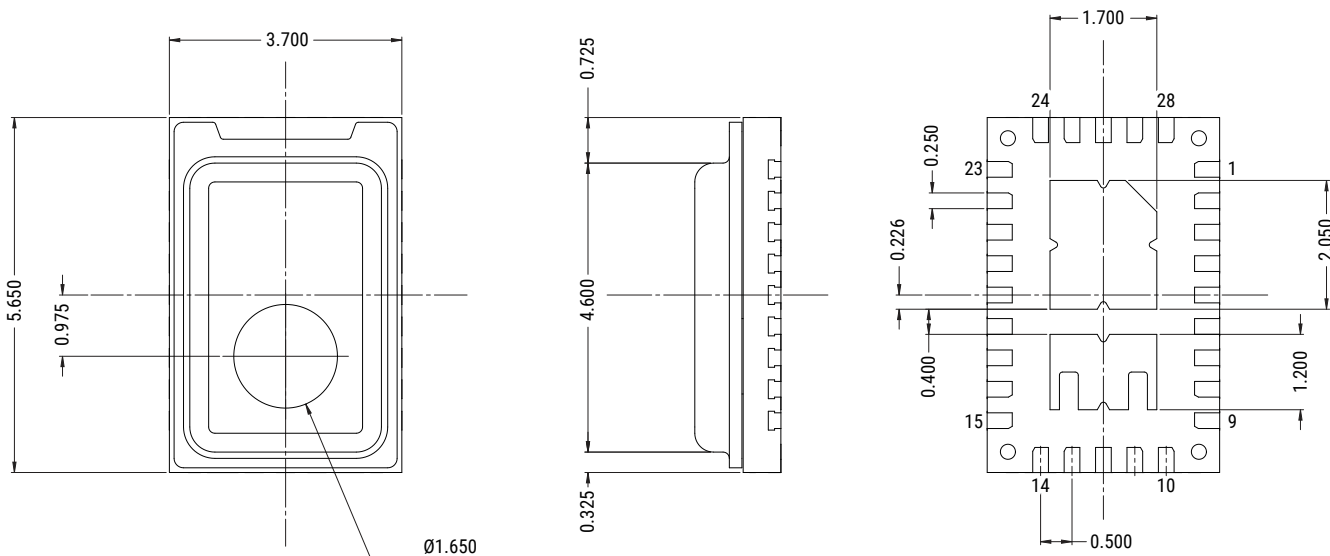

USEQGSEA\*\*\*\*\* Low Profile

USEQGEH\*\*\*\*\* High Profile

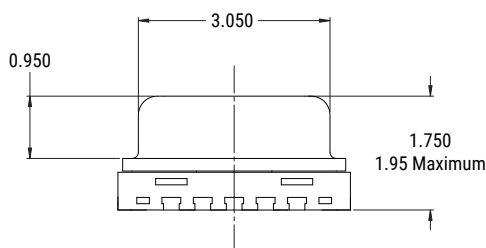
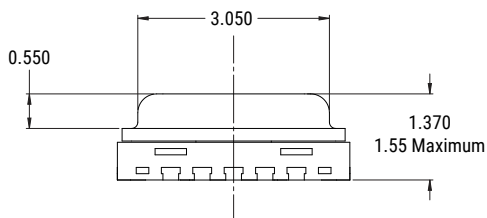

### Pin Configuration of the Sensor

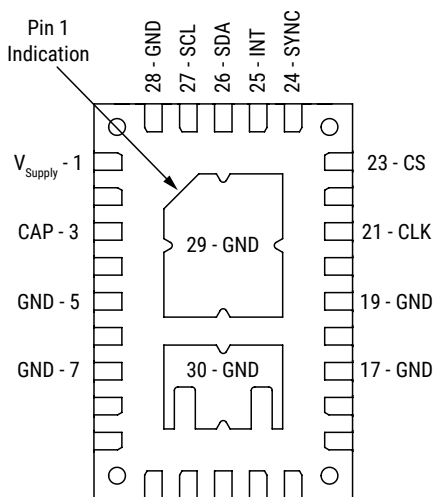

Transparent Top View

## Recommended Circuit Diagram

### Single Device Block Diagram

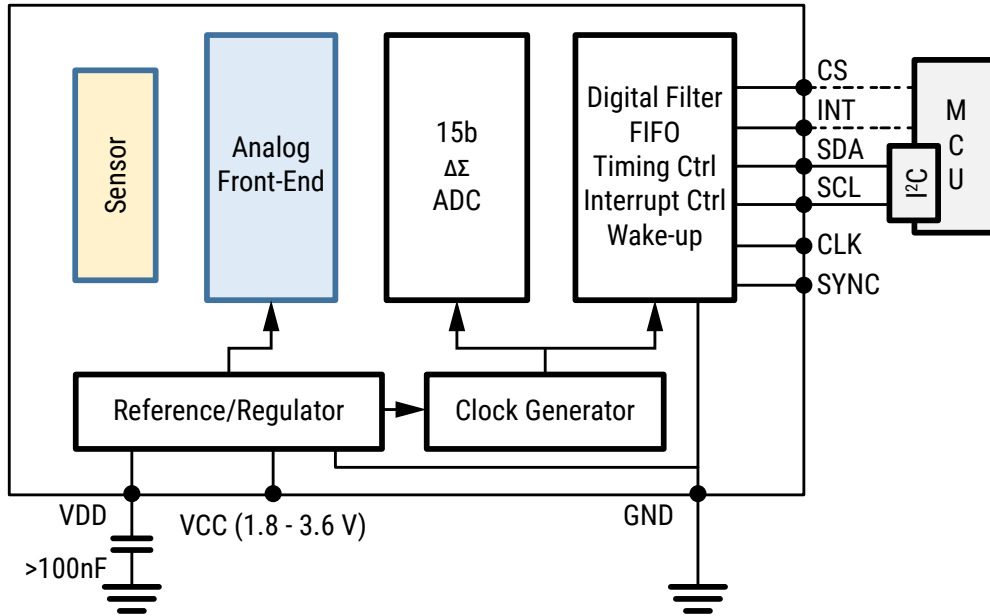

### Three Devices with Synchronised Sampling

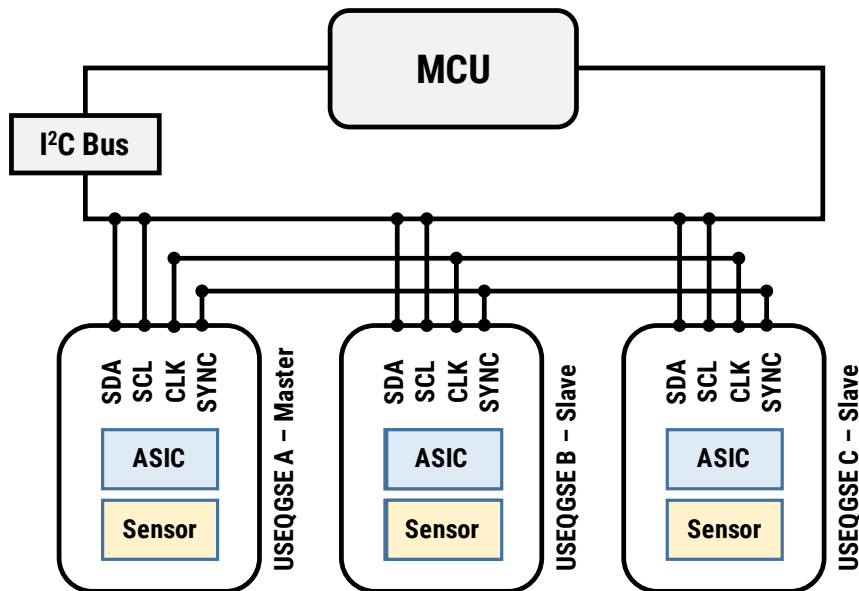

## Recommended Circuit Diagram cont.

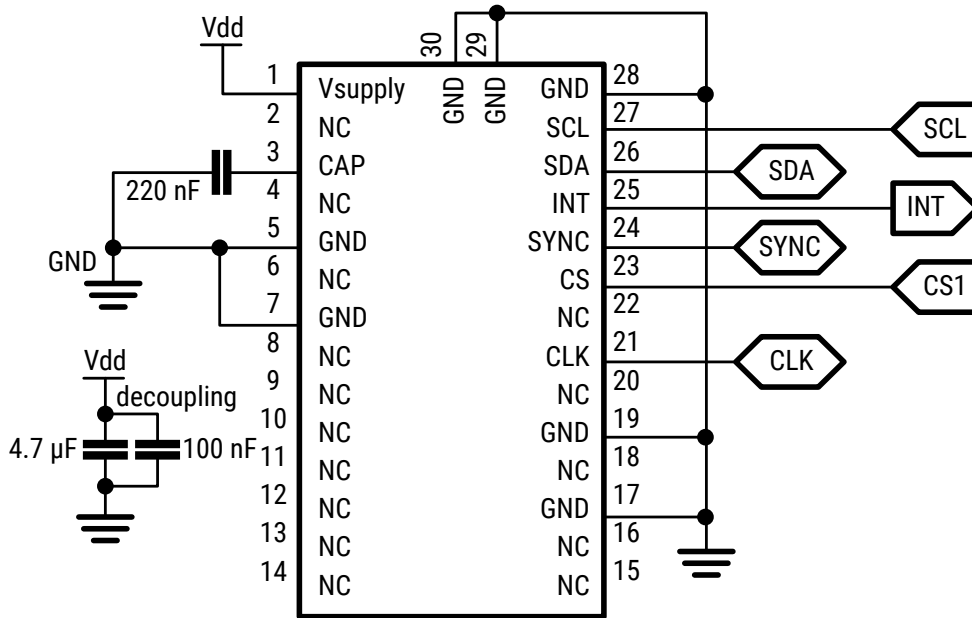

## Field of View

USEQGSEA\*\*\*\*\* Low Profile

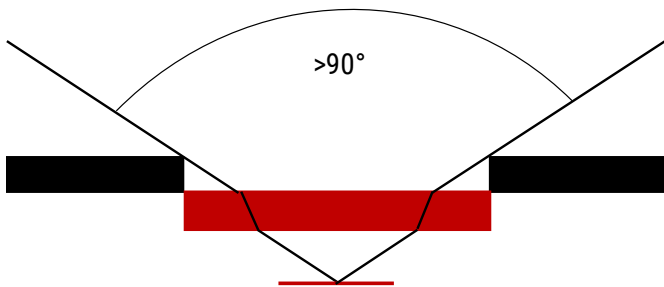

USEQGSEH\*\*\*\*\* High Profile

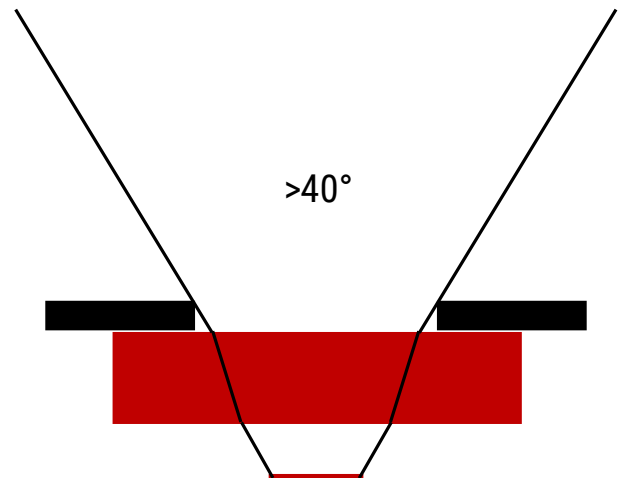

## Performance Characteristics

### Signal Filtering & Power Modes

Power Mode (base sample rate)	High Pass Filter – Analog (Hz)					Fixed Analog Low Pass Filter (Hz)	Fixed Digital Low Pass Filter (Hz)	Digital Low Pass Filter (Hz)				Maximum ADC Sampling Rate (sps)
	Off	1.0	2.0	4.0	8.0			180.0	90.0	45.0	22.5	
Normal Power Mode	Off	1.0	2.0	4.0	8.0	600	250	180.0	90.0	45.0	22.5	1,000
Low Power Mode	Off	0.17	0.33	0.66	1.30	100	42	30.00	15.00	7.50	3.75	166

Item	Mode	Description	Typical Current Consumption (1.8 V, room temperature)
Power consumption	Normal Power Mode	Normal power consumption, 1 kHz maximum sample rate	22 $\mu$ A
	Low Power Mode	Low power consumption, 166 Hz maximum sample rate	3.5 $\mu$ A
Operational state	Normal Operation Mode	Sensor signal readout over I <sup>2</sup> C	22 $\mu$ A
	Sleep Mode	Hardware interrupt on infrared trigger	21 $\mu$ A (Normal Power Mode) 3.5 $\mu$ A (Low Power Mode)
	Power Down Mode	Sensor is disabled	1.1 $\mu$ A

### Infrared Frequency Characteristics

Typical Frequency Response in Normal Power Mode

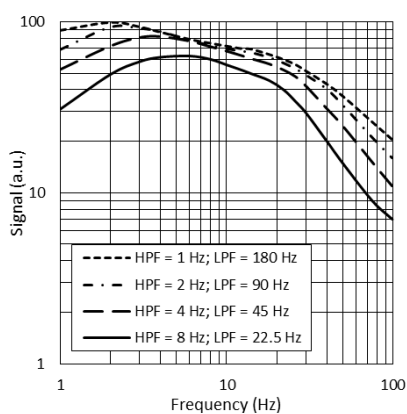

Typical Frequency Response in Low Power Mode

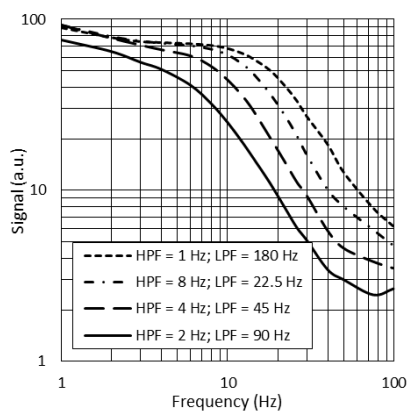

Typical Frequency Response at Different Gain Settings

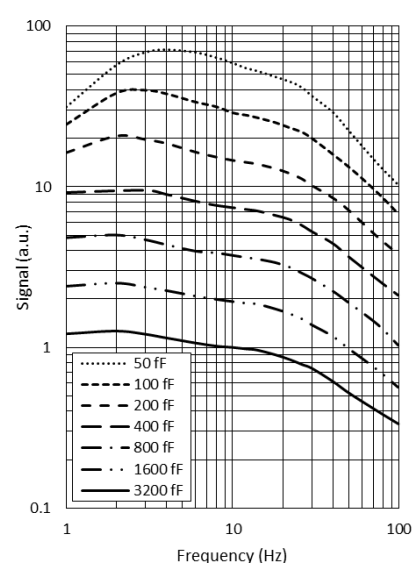

## Part Number Specifications

### Sensor Characteristics

Filter Aperture (mm)	Element Size (mm <sup>2</sup> )	SMD Package (mm)	D* <sup>1</sup> (cm√Hz/W) Typical	NEP <sup>1</sup> (W/√Hz) Typical	Time Constant (ms) at 10-20 Hz peak	Field of View
φ 1.65	0.64 x 0.64	5.65 x 3.70 x 1.55	2.5 x 10 <sup>8</sup>	2.7 x 10 <sup>-10</sup>	~10	~90°

<sup>1</sup> 10 Hz, 500 K, room temperature, without window and optics.

### Electrical Characteristics

Supply Voltage (V)	Supply Current (μA) Typical	Digital I/O	ΔΣ ADC at 1 ksp	Operating Temperature Range (°C)	Storage Temperature Range (°C)	Sensor Read-out	Configurable
1.75 to 3.60	1 to 23	I <sup>2</sup> C (FM+ compatible)	15 bit	-40 to +85	-40 to +110	Current mode	Gain Digital filtering Sampling rate Power modes

### Part Number (Sensor)

Part Number	Filter (μm)	Filter BW (nm)	Use	Weight (gr)
USEQGSEAC82180	4.26	180	CO <sub>2</sub>	0.07
USEQGSEACH4180	3.30	160	CH <sub>4</sub>	0.07
USEQGSEAN8L180	5.30	180	NO	0.07
USEQGSEH950180	9.50	400	Sugar, Ethanol	0.08

Below flame sensors from the QFS series can also be used for gas detection or analysis, more details about these products available on [https://content.kemet.com/datasheets/KEM\\_SE0211\\_QFS.pdf](https://content.kemet.com/datasheets/KEM_SE0211_QFS.pdf)

Part Number	Filter (μm)	Filter BW (nm)	Use	Weight (gr)
USEQFSEA391180	3.91	90	Reference	0.07
USEQFSEA22L180 <sup>1</sup>	2.20	Long pass	Broadband	0.07
USEQFSEA50L180 <sup>1</sup>	5.00	Long pass	Broadband	0.07
USEQFSEA464180 <sup>2</sup>	4.64	180	CO	0.07

<sup>1</sup> Used with bespoke, customer or application-specific (narrowband) filters mounted externally.

<sup>2</sup> Used as gas or active filter.



## Landing Pattern

### Recommended PCB Landing Pattern – Millimeters

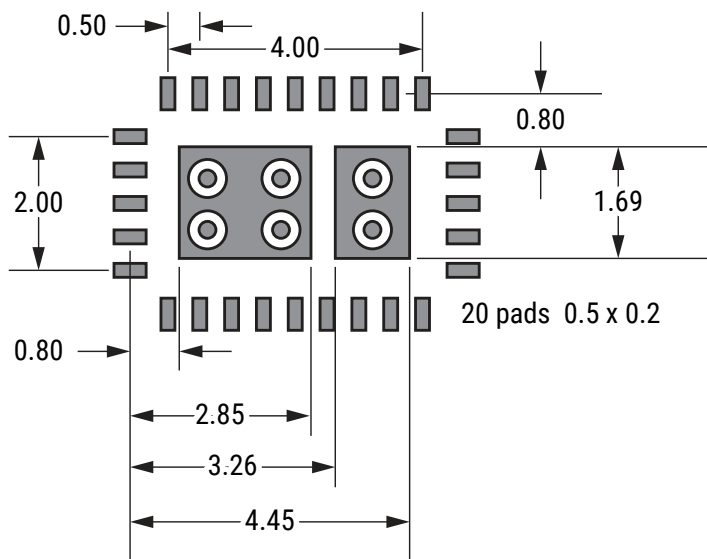

## Soldering Process

### Recommended Reflow Soldering Profile

Profile Feature	Pb-Free Assembly
<b>Preheat/Soak</b>	
Temperature Minimum ( $T_{smin}$ )	150°C
Temperature Maximum ( $T_{smax}$ )	200°C
Time ( $t_s$ ) from $T_{smin}$ to $T_{smax}$	60 – 120 seconds
Ramp-Up Rate ( $T_L$ to $T_p$ )	3°C/second maximum
Liquidous Temperature ( $T_L$ )	217°C
Time Above Liquidous ( $t_L$ )	60 – 150 seconds
Peak Temperature ( $T_p$ )	260°C
Time within 5°C of Maximum Peak Temperature ( $t_p$ ) <sup>1</sup>	30 seconds maximum
Ramp-Down Rate ( $T_p$ to $T_L$ )	6°C/second maximum
Time 25°C to Peak Temperature	8 minutes maximum

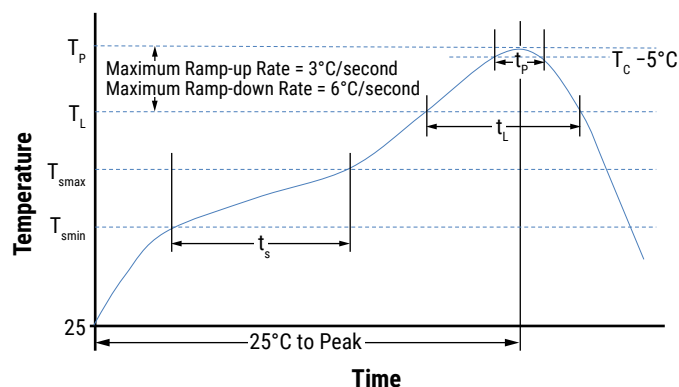

<sup>1</sup> Tolerance for peak profile temperature (TP) is defined as a supplier minimum and as a user maximum.

## Packaging

Part Number	Packaging Type	Pieces Per Reel
USEQGS*****	7" Tape & Reel	800

## Taping Specification

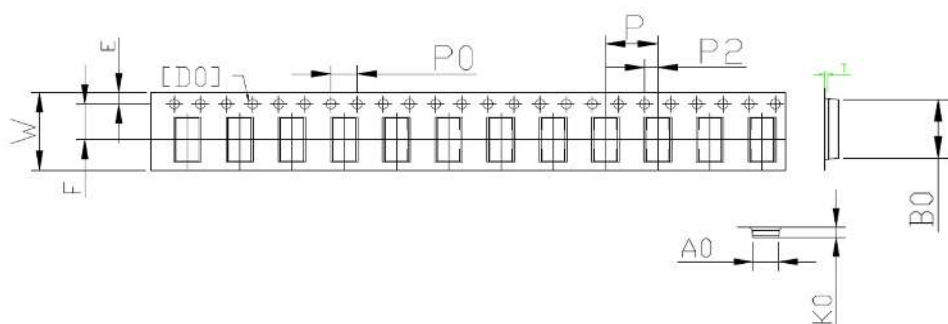

### USEQGSEA\*\*\*\*\* Low Profile

	Dimensions (mm)										
	P0	P	T	P2	W	A0	B0	K0	E	F	D0
Minimum	3.90	7.90	0.25	1.90	11.70	3.90	5.85	1.65	1.65	5.40	1.50
Typical	4.00	8.00	0.30	2.00	12.00	4.00	5.95	1.75	1.75	5.50	1.50
Maximum	4.10	8.10	0.35	2.10	12.30	4.10	6.05	1.85	1.85	5.60	1.60

### USEQSEH\*\*\*\*\* High Profile

	Dimensions (mm)										
	P0	P	T	P2	W	A0	B0	K0	E	F	D0
Minimum	3.90	7.90	0.25	1.90	11.70	3.90	5.85	2.05	1.65	5.40	1.50
Typical	4.00	8.00	0.30	2.00	12.00	4.00	5.95	2.15	1.75	5.50	1.50
Maximum	4.10	8.10	0.35	2.10	12.30	4.10	6.05	2.25	1.85	5.60	1.60

## Reel Specification

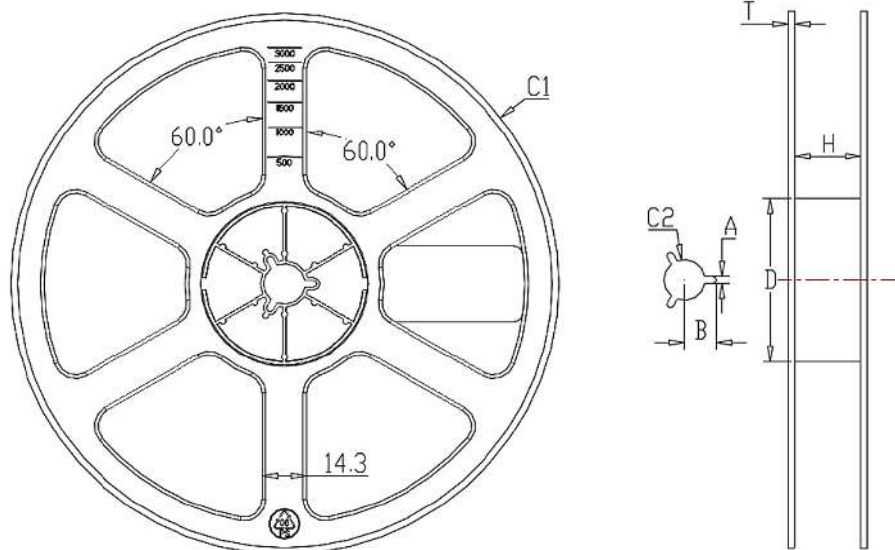

	Dimensions (mm)						
	C1	C2	A	B	H	T	D
Tolerance	±1.0	±0.2	±0.2	±0.2	±0.5	±0.2	±0.5
Nominal	Ø178	13.5	2.3	10.4	12.5	1.6	Ø54

## Handling Precautions

Pyroelectric Infrared Sensors should be kept away from indirect and direct sunlight, the headlights of cars, wind, and exposure to strong vibration and strong shock.

Do not use in water, alcohol ETA, corrosive gas or under sea breeze.

Do not be expose to corrosive substances.

Do not drop or apply any mechanical stress.

The performance of this device can be affected by ESD. Precautions should be used when handling and installing the sensor. Precision devices such as this sensor can be damaged or caused not to meet published specification due to ESD. Please note that there is limited ESD protection built-in as the device is optimised for low power consumption and low noise operation. Human Body Model (HBM), per JS-001: 2,000 V.

Pyroelectric Infrared Sensors should be stored in normal working environments.

Solderability will be degraded by exposure to high temperatures, high humidity, corrosive atmospheres, and long-term storage.

KEMET recommends that ambient storage conditions are < 30°C and < 60% relative humidity and that maximum storage temperature does not exceed 110°C. Atmospheres should be free of chlorine and sulfur-bearing compounds.

Temperature fluctuations should be minimized to avoid condensation on the parts.

For optimized solderability sensors stock should be used promptly, preferably within 24 months of receipt.

## KEMET Electronics Corporation Sales Offices

For a complete list of our global sales offices, please visit [www.kemet.com/sales](http://www.kemet.com/sales).

---

### Disclaimer

All product specifications, statements, information and data (collectively, the "Information") in this datasheet are subject to change. The customer is responsible for checking and verifying the extent to which the Information contained in this publication is applicable to an order at the time the order is placed. All Information given herein is believed to be accurate and reliable, but it is presented without guarantee, warranty, or responsibility of any kind, expressed or implied.

Statements of suitability for certain applications are based on KEMET Electronics Corporation's ("KEMET") knowledge of typical operating conditions for such applications, but are not intended to constitute – and KEMET specifically disclaims – any warranty concerning suitability for a specific customer application or use. The Information is intended for use only by customers who have the requisite experience and capability to determine the correct products for their application. Any technical advice inferred from this Information or otherwise provided by KEMET with reference to the use of KEMET's products is given gratis, and KEMET assumes no obligation or liability for the advice given or results obtained.

Although KEMET designs and manufactures its products to the most stringent quality and safety standards, given the current state of the art, isolated component failures may still occur. Accordingly, customer applications which require a high degree of reliability or safety should employ suitable designs or other safeguards (such as installation of protective circuitry or redundancies) in order to ensure that the failure of an electrical component does not result in a risk of personal injury or property damage.

Although all product-related warnings, cautions and notes must be observed, the customer should not assume that all safety measures are indicated or that other measures may not be required.

When providing KEMET products and technologies contained herein to other countries, the customer must abide by the procedures and provisions stipulated in all applicable export laws and regulations, including without limitation the International Traffic in Arms Regulations (ITAR), the US Export Administration Regulations (EAR) and the Japan Foreign Exchange and Foreign Trade Act.

*KEMET is a registered trademark of KEMET Electronics Corporation.*