



EV3910-K-00B

Peak Current Mode PWM Controller Boost Evaluation Board

DESCRIPTION

The EV3910-K-00B evaluation board is designed to demonstrate the capabilities of the MP3910, a peak current mode PWM controller that can drive an external MOSFET capable of handling over 10A of current. The device can accommodate offline, telecom, and non-isolated and isolated applications.

When designed for boost applications, the 1A gate driver minimizes the power loss of the external MOSFET while allowing the use of a wide variety of standard threshold devices. Additionally, MP3910 has pulse-skip mode to improve efficiency under light-load or no-load conditions.

The MP3910 is available in an MSOP-10 package.

ELECTRICAL SPECIFICATIONS

Parameter	Symbol	Value	Units
Input voltage	V_{IN}	10 to 20	V
Output voltage	V_{OUT}	24	V
Output current	I_{OUT}	2	A

FEATURES

- Wide 5V to 35V Supply Voltage Range
- 1A, 12V MOSFET Gate Driver
- External Soft-Start
- Pulse-Skip Operation under Light Loads
- Configurable Switching Frequency (30kHz to 400kHz)
- Synchronizable from 80kHz to 400kHz
- Cycle-by-Cycle Current Limit
- Over-Voltage Protection (OVP)
- Available in an MSOP-10 Package

APPLICATIONS

- Telecom Isolated Power
- Brick Modules
- Offline Controllers
- General Step-Up Applications

All MPS parts are lead-free, halogen-free, and adhere to the RoHS directive. For MPS green status, please visit the MPS website under Quality Assurance. "MPS", the MPS logo, and "Simple, Easy Solutions" are trademarks of Monolithic Power Systems, Inc. or its subsidiaries.

EV3910-K-00B EVALUATION BOARD

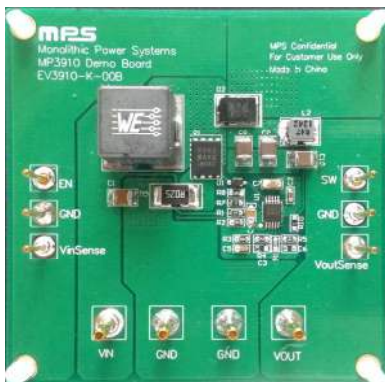

LxWxH (6.35cmx6.35cmx1.2cm)

Board Number	MPS IC Number
EV3910-K-00B	MP3910GK

Efficiency vs. Load Current

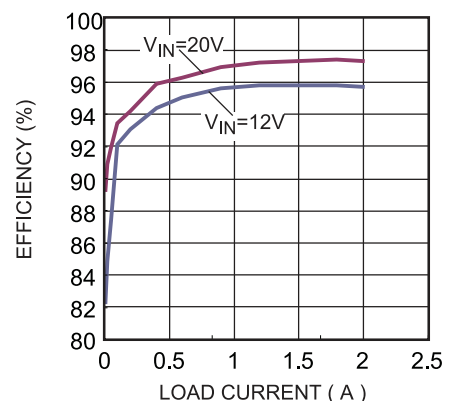

QUICK START GUIDE

1. Connect the load terminals to:
 - a. Positive (+): VOUT
 - b. Negative (-): GND
2. Preset the power supply output between 10V and 20V, and then turn the power supply off.
3. Connect the power supply output terminals to:
 - a. Positive (+): VIN
 - b. Negative (-): GND
4. Turn the power supply on. The EV3910-K-00B should automatically start up.
5. To use the enable function, apply a digital input to the EN pin. Drive EN above 2V to turn the regulator on; drive EN below 1V to turn it off.

EVALUATION BOARD SCHEMATIC

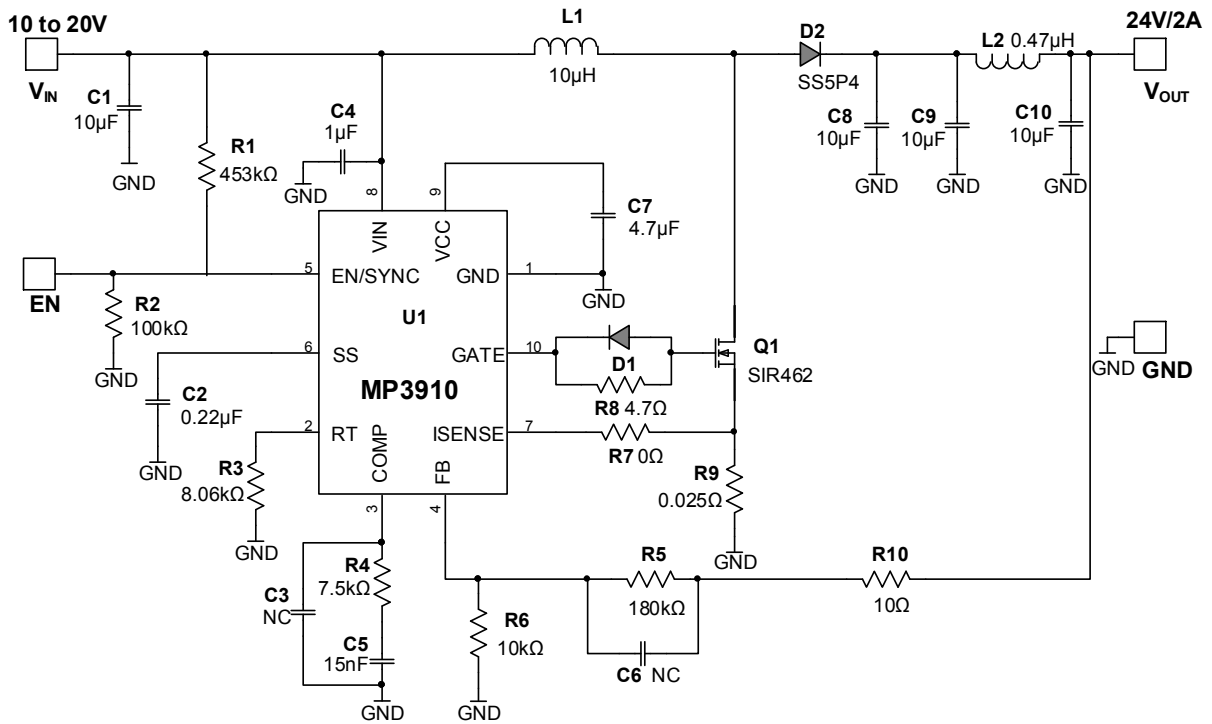

Figure 1: Evaluation Board Schematic

EV3910-K-00B BILL OF MATERIALS

Qty	Ref	Value	Description	Package	Manufacturer	Manufacturer PN
1	C1	10 μ F	Ceramic capacitor, 25V, X7R	1210	Murata	GRM32DR71E106KA12L
1	C2	0.22 μ F	Ceramic capacitor, 16V, X7R	0603	Murata	GRM188R71C224KA01D
2	C3, C6	NC				
1	C4	1.0 μ F	Ceramic capacitor, 25V, X7R	0805	Murata	GRM21BR71E105KA99L
1	C5	15nF	Ceramic capacitor, 50V, X7R	0603	Murata	GRM188R71H153KA01D
1	C7	4.7 μ F	Ceramic capacitor, 16V, X7R	0805	Murata	GRM21BR71C475KA73L
3	C8, C9, C10	10 μ F	Ceramic capacitor, 50V, X5R	1210	Murata	GRM32ER61H106KA12L
1	R1	453k Ω	Film resistor, 1%	0603	Royal	RL0603FR-07453KL
1	R2	100k Ω	Film resistor, 1%	0603	Royal/Lizhi	RL0603FR-07100KL
1	R3	8.06k Ω	Film resistor, 1%	0603	Royal	RL0603FR-078K06L
1	R4	7.5k Ω	Film resistor, 1%	0603	Royal	RL0603FR-077K5L
1	R5	180k Ω	Film resistor, 1%	0603	Royal	RL0603FR-07180KL
1	R6	10k Ω	Film resistor, 1%	0603	Royal	RL0603FR-0710KL
2	R7, R10	0 Ω	Film resistor, 1%	0603	Yageo	RC0603FR-070RL
1	R8	4.7 Ω	Film resistor, 1%	0603	Royal	RL0603FR-074R7L
1	R9	0.025 Ω		2512	Yageo	RL2512FK-070R025L
1	D1	75V	Diode, 75V, 250mW	SOD-323	Diodes Inc	1N4148WS-7
1	D2	40V	Switching diode, 40V, 5A	TO-277A	Vishay	SS5P4
1	L1	10 μ H	L = 10 μ H, I _R = 7.8A, R _{DC} = 19m Ω	SMD	MPS	MPL-AY1050-100
			L = 10 μ H, I _R = 9A, R _{DC} = 14.4m Ω	SMD	Würth	744 332 100 0
1	L2	0.47 μ H	L = 0.47 μ H, I _R = 9.2A, R _{DC} = 6.2m Ω	SMD	MPS	MPL-AL4020-R47
			L = 0.47 μ H, I _R = 6.8A, R _{DC} = 11.2m Ω	SMD	Würth	744 373 240 047
1	Q1	30V	V _{DS} = 30V, R _{DS(ON)} = 7.9m Ω	PowerPAK® SO-8	Vishay	SiR462DP
1	U1	MP3910	Controller	MSOP-10	MPS	MP3910GK

EVB TEST RESULTS

Performance waveforms are tested on the evaluation board. $V_{IN} = 12V$, $V_{OUT} = 24V$, $I_{OUT} = 2A$, $T_A = 25^\circ C$, unless otherwise noted.

Efficiency vs. Load Current

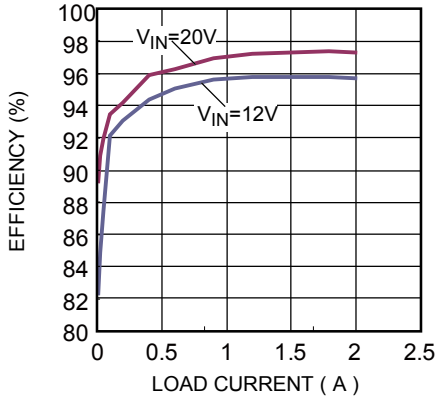

Load Regulation vs. Load Current
 $V_{IN} = 12V$

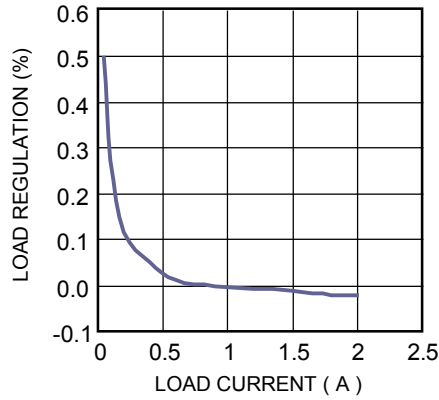

Line Regulation vs. Input Voltage

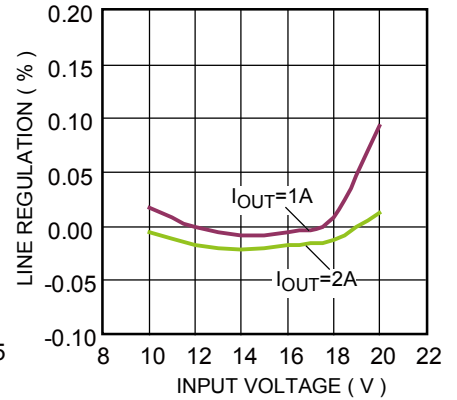

Magnitude and Phase vs. Frequency

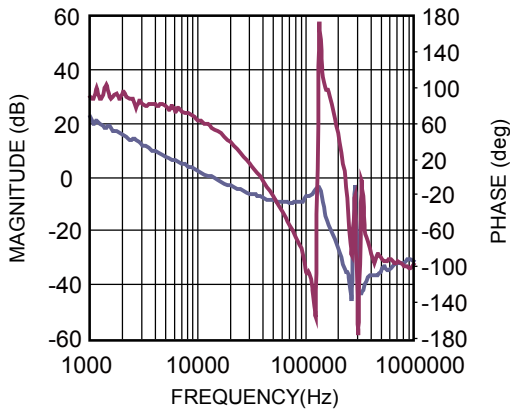

EVB TEST RESULTS (continued)

Performance waveforms are tested on the evaluation board. $V_{IN} = 12V$, $V_{OUT} = 24V$, $I_{OUT} = 2A$, $T_A = 25^\circ C$, unless otherwise noted.

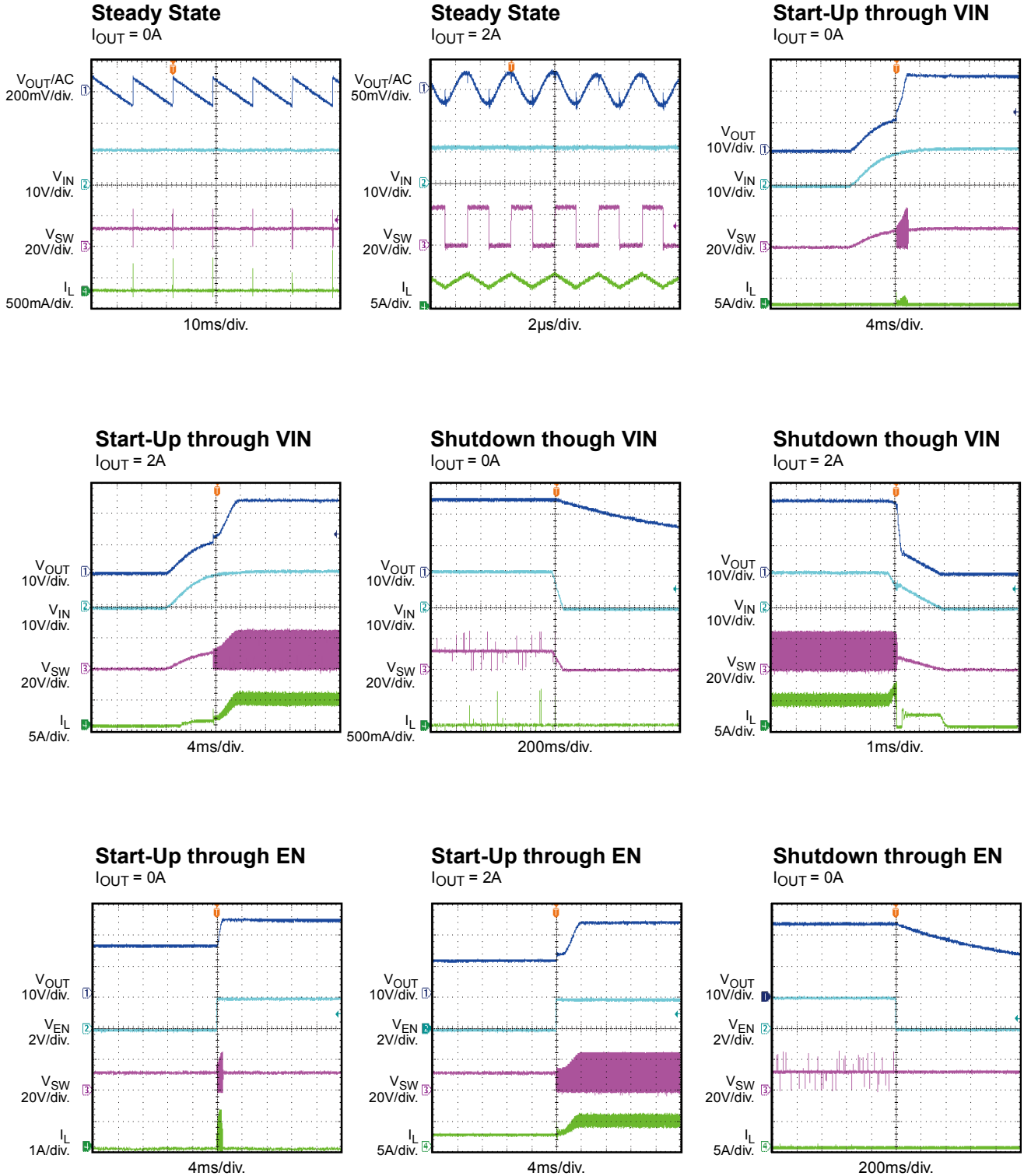

EVB TEST RESULTS (continued)

Performance waveforms are tested on the evaluation board. $V_{IN} = 12V$, $V_{OUT} = 24V$, $I_{OUT} = 2A$, $T_A = 25^\circ C$, unless otherwise noted.

Shutdown through EN

$I_{OUT} = 2A$

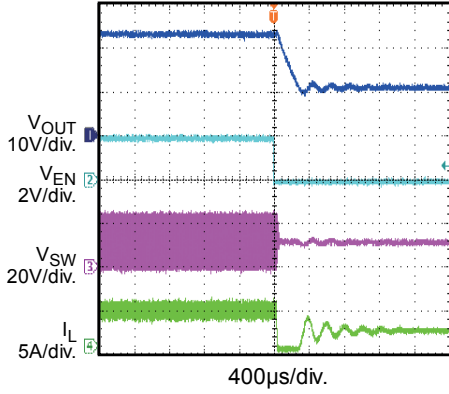

Load Transient

$I_{OUT} = 1A$ to $2A$, $I_{RAMP} = 25mA/\mu s$

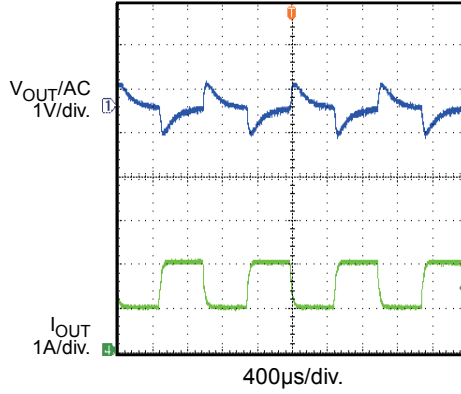

PCB LAYOUT

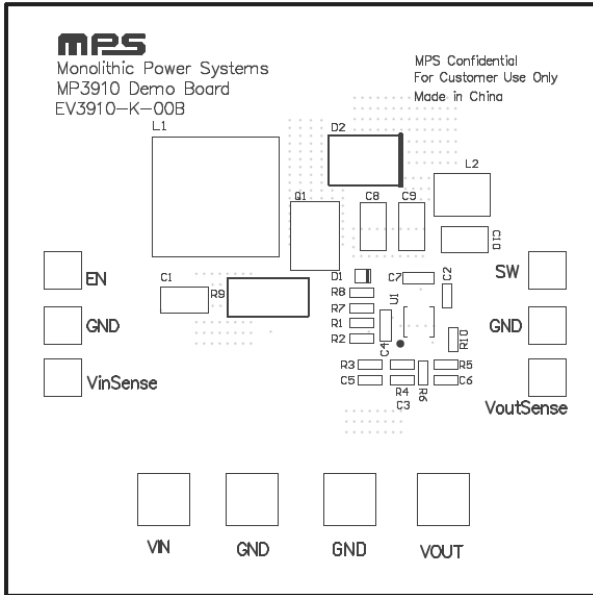

Figure 2: Top Silk Layer

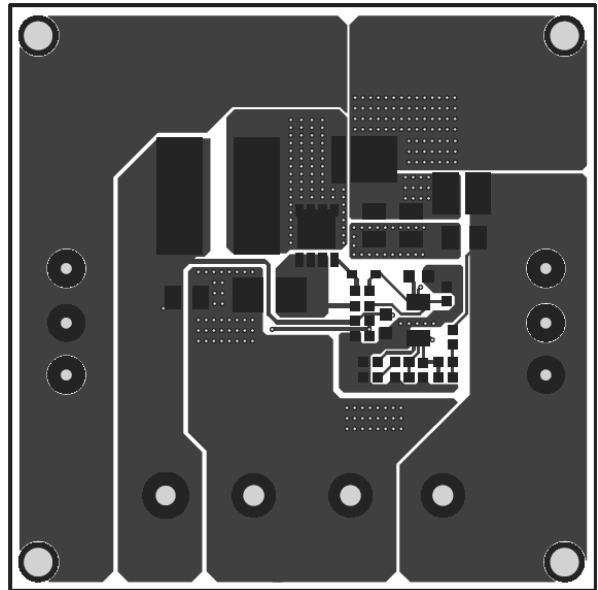

Figure 3: Top Layer

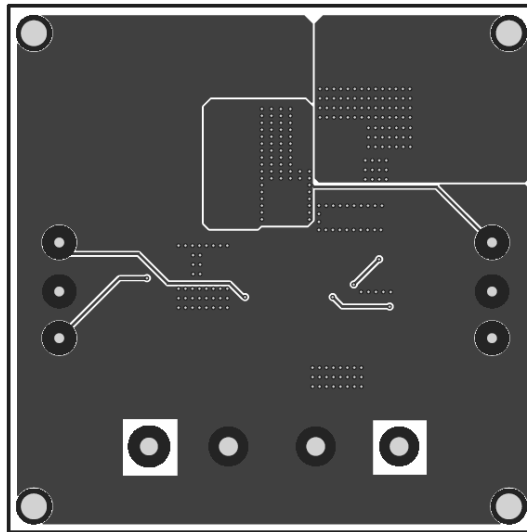

Figure 4: Bottom Layer



REVISION HISTORY

Revision #	Revision Date	Description	Pages Updated
1.0	4/5/2014	Initial Release	-
1.1	6/28/2021	Add MPS inductor information.	4

Notice: The information in this document is subject to change without notice. Please contact MPS for current specifications. Users should warrant and guarantee that third-party Intellectual Property rights are not infringed upon when integrating MPS products into any application. MPS will not assume any legal responsibility for any said applications.